



High Speed CMOS Multilevel Pipeline Registers

QS29FCT520T
QS29FCT521T

QS29FCT2520T
QS29FCT2521T

FEATURES/BENEFITS

- Pin and function compatible to the Am29520
- Ground bounce controlled outputs
- Reduced output swing of 0-3.5V
- Available in DIP, ZIP, SOIC, QSOP, HQSOP
- TTL-compatible input and output levels
- CMOS power levels: <7.5 mW static
- Undershoot clamp diodes on all inputs
- Military product compliant to MIL-STD-883

FCT-T520T/1T

- JEDEC-FCT spec compatible
- Fastest CMOS logic family available
- A, B, and C speed grades with 6 ns t_{PD} for C
- $I_{OL} = 48$ mA Com., 32 mA Mil.

FCT-T 2520T/1T

- Built-in 25Ω series resistor outputs reduce reflection and other system noise
- A, B, and C speed grades with 6 ns t_{PD} for C
- $I_{OL} = 12$ mA Com.

DESCRIPTION

The QS29FCT520AT/BT and QS29FCT521AT/BT provide four 8-bit registers useful for temporary storage and for stage delays in pipelined systems. The four registers may be configured as a dual 2-level or single 4-level shift register pipeline. A single 8-bit input is provided, and any of the four registers may be selected for gating to the single 8-bit output. The 520 and 521 differ only in how the registers are loaded in the dual 2-rank mode, as shown in the function tables. The QS29FCT520/1 are pin and function compatible with the Am29520/1 bipolar parts, except for higher speed and significantly lower power.

FUNCTIONAL BLOCK DIAGRAM

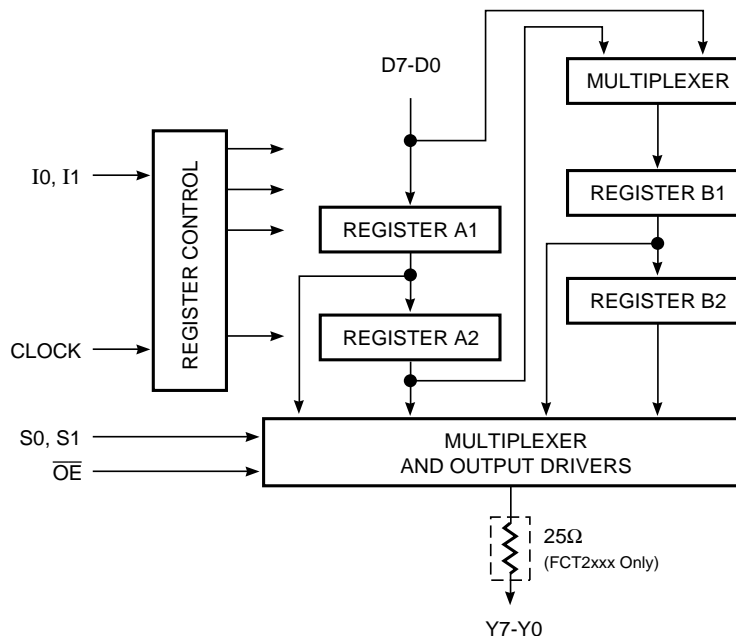

PIN CONFIGURATIONS (All Pins Top View)

PDIP, SOIC, QSOP, HQSOP

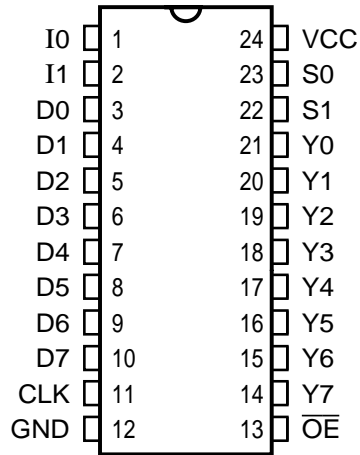

ZIP

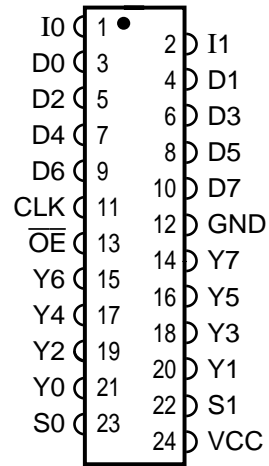

PIN DESCRIPTION

Name	I/O	Description
D7-D0	I	Data Inputs
Y7-Y0	O	Data Outputs - Three State
I0, I1	I	Register Load Control
S0, S1	I	Register Output Select
CLK	I	Clock Pulse
\overline{OE}	I	Output Enable

FUNCTION TABLES

REGISTER LOAD CONTROL

PART NO	Register Control Code			
	I1,0 = LL = 0	I1,0 = LH = 1	I1,0 = HL = 2	I1,0 = HH = 3
FCT520				Hold Data
FCT521				Hold Data

REGISTER OUTPUT SELECTION

S1	S0	\overline{OE}	Y1	Register to Y7-Y0
L	L	L	Data	B2
L	H	L	Data	B1
H	L	L	Data	A2
H	H	L	Data	A1
X	X	H	Hi-Z	Outputs Disabled

ABSOLUTE MAXIMUM RATINGS

Supply Voltage to Ground	-0.5V to +7.0V
DC Output Voltage V_{OUT}	-0.5V to +7.0V
DC Input Voltage V_{IN}	-0.5V to +7.0V
AC Input Voltage (for a pulse width ≤ 20 ns)	-3.0V
DC Input Diode Current with $V_{IN} < 0$	-20 mA
DC Output Diode Current with $V_{OUT} < 0$	-50 mA
DC Output Current Max. Sink Current/Pin	120 mA
Maximum Power Dissipation	0.5 watts
T_{STG} Storage Temperature	-65° to +150°C

Note: Stresses greater than those listed under ABSOLUTE MAXIMUM RATINGS may cause permanent damage to this device resulting in functional or reliability type failures.

CAPACITANCE

$T_A = 25^\circ\text{C}$, $f = 1$ MHz, $V_{IN} = 0\text{V}$, $V_{OUT} = 0\text{V}$

Pins	SOIC	QSOP	PDIP	ZIP	Unit
1-11, 13, 22, 23	4	4	5	7	pF
14-21	6	6	7	9	pF
—	8	8	9	10	pF

Note: Capacitance is characterized but not tested.

POWER SUPPLY CHARACTERISTICS

Symbol	Parameter	Test Conditions ⁽¹⁾	Min	Max	Unit
I_{CC}	Quiescent Power Supply Current	$V_{CC} = \text{Max.}$, $\text{freq} = 0$ $0\text{V} \leq V_{IN} \leq 0.2\text{V}$ or $V_{CC} - 0.2\text{V} \leq V_{IN} \leq V_{CC}$	—	1.5	mA
ΔI_{CC}	Supply Current per Input @ TTL HIGH	$V_{CC} = \text{Max.}$, $V_{IN} = 3.4\text{V}$, $\text{freq} = 0$ ⁽²⁾	—	2.0	mA
Q_{CCD}	Supply Current per Input per MHz	$V_{CC} = \text{Max.}$, Outputs Open and Enabled One Bit Toggling @ 50% Duty Cycle Other Inputs at GND or V_{CC} ^(3,4)	—	0.25	mA/ MHz

Notes:

- For conditions shown as Min. or Max., use the appropriate values specified under DC specifications.
- Per TTL driven input ($V_{IN} = 3.4\text{V}$).
- For flip-flops, Q_{CCD} is measured by switching one of the data input pins so that the output changes every clock cycle. This is a measurement of device power consumption only and does not include power to drive load capacitance or tester capacitance. This parameter is guaranteed by design but not tested.
- I_C can be computed using the above parameters as explained in the Technical Overview section.

QS29FCT520T, 521T, 2520T, 2521T

DC ELECTRICAL CHARACTERISTICS OVER OPERATING RANGE

Commercial $T_A = 0^\circ\text{C}$ to 70°C , $V_{CC} = 5.0\text{V} \pm 5\%$

Military $T_A = -55^\circ\text{C}$ to 125°C , $V_{CC} = 5.0\text{V} \pm 10\%$

Symbol	Parameter	Test Conditions	Min	Typ ⁽¹⁾	Max	Unit
V_{IH}	Input HIGH Voltage	Logic HIGH for All Inputs	2.0	—	—	V
V_{IL}	Input LOW Voltage	Logic LOW for All Inputs	—	—	0.8	V
ΔV_T	Input Hysteresis	$V_{TLH} - V_{THL}$ for All Inputs	—	0.2	—	V
$ I_{IH} $ $ I_{IL} $	Input Current Input HIGH or LOW	$V_{CC} = \text{Max.}, 0 \leq V_{IN} < V_{CC}$	—	—	5	μA
$ I_{OZ} $	Off-State Output Current (Hi-Z)	$V_{CC} = \text{Max.}, 0 \leq V_{IN} \leq V_{CC}$	—	—	5	μA
I_{OS}	Short Circuit Current (FCTXXX)	$V_{CC} = \text{Max.}, V_{OUT} = \text{GND}^{(2,3)}$	-60	—	—	mA
I_{OR}	Current Drive (FCT2XXX)	$V_{CC} = \text{Min.}, V_{OUT} = 2.0\text{V}^{(3)}$	50	—	—	mA
V_{IC}	Input Clamp Voltage	$V_{CC} = \text{Min.}, I_{IN} = -18 \text{ mA}, T_A = 25^\circ\text{C}^{(3)}$	—	-0.7	-1.2	V
V_{OH}	Output HIGH Voltage	$V_{CC} = \text{Min.}, I_{OH} = -12 \text{ mA (MIL)}$ $I_{OH} = -15 \text{ mA (COM)}$	2.4 2.4	— —	— —	V
V_{OL}	Output LOW Voltage (FCTXXX)	$V_{CC} = \text{Min.}, I_{OL} = 32 \text{ mA (MIL)}$ $I_{OL} = 48 \text{ mA (COM)}$	— —	— —	0.50 0.50	V
V_{OL}	Output LOW Voltage (FCT2XXX – 25 Ω)	$V_{CC} = \text{Min.}, I_{OL} = 12 \text{ mA (MIL)}$ $I_{OL} = 12 \text{ mA (COM)}$	— —	— —	0.50 0.50	V
R_{OUT}	Output Resistance (FCT2XXX – 25 Ω)	$V_{CC} = \text{Min.}, I_{OL} = 12 \text{ mA (MIL)}$ $I_{OL} = 12 \text{ mA (COM)}$	— 20	25 28	— 40	Ω

Notes:

1. Typical values indicate $V_{CC} = 5.0\text{V}$ and $T_A = 25^\circ\text{C}$.
2. Not more than one output should be shorted and the duration is ≤ 1 second.
3. These parameters are guaranteed by design but not tested.

QS29FCT520T, 521T, 2520T, 2521T

SWITCHING CHARACTERISTICS OVER OPERATING RANGE

Commercial T_A = 0°C to 70°C, V_{CC} = 5.0V ± 5%

Military T_A = -55°C to 125°C, V_{CC} = 5.0V ± 10%

C_{LOAD} = 50 pF, R_{LOAD} = 500Ω unless otherwise noted.

Symbol	Description		29FCT 520/1A 2520/1A		29FCT 520/1B 2520/1B		29FCT 520/1C 2520/1C		Unit
			Min	Max	Min	Max	Min	Max	
tCPD	Clock to Y Delay ⁽¹⁾	Com	2	14	2	7.5	2	6	ns
		Mil	2	16	2	8	2	7	
tDY	S0, S1 to Y Delay ⁽¹⁾	Com	5	13	2.5	7.5	2	6	ns
		Mil	6	15	2	8	2	7	
tDS	Data to CLK Setup Time	Com	5	—	2.5	—	2.5	—	ns
		Mil	6	—	2.8	—	2.8	—	
tDH	Data to CLK Hold Time	Com	2	—	2	—	2	—	ns
		Mil	2	—	2	—	2	—	
tIS	I0, I1 to CLK Setup Time	Com	5	—	4	—	4	—	ns
		Mil	6	—	4.5	—	4.5	—	
tIH	I0, I1 to CLK Hold Time	Com	2	—	2	—	2	—	ns
		Mil	2	—	2	—	2	—	
toZ	Output Disable Time ⁽²⁾ OE to Y	Com	1.5	12	1.5	7	1.5	6	ns
		Mil	1.5	13	1.5	7.5	1.5	6	
toE	Output Enable Time ⁽¹⁾ OE to Y	Com	1.5	15	1.5	7.5	1.5	6	ns
		Mil	1.5	16	1.5	8	1.5	7	
tcw	CLK Pulse Width, ⁽²⁾ HIGH or LOW	Com	7	—	5.5	—	5.5	—	ns
		Mil	8	—	6	—	6	—	

Notes:

1. Minimums guaranteed but not tested.
2. This parameter is guaranteed by design but not tested.
3. See Test Circuit and Waveforms.

300-MIL PDIP - Package Code P
Plastic Dual In-line Package

Notes:

1. Refer to applicable symbol list.
2. All dimensions are in inches.
3. N is the number of lead positions.
4. Dimensions D and E1 are to be measured at maximum material condition but do not include mold flash. Allowable mold flash is 0.010in. per side.

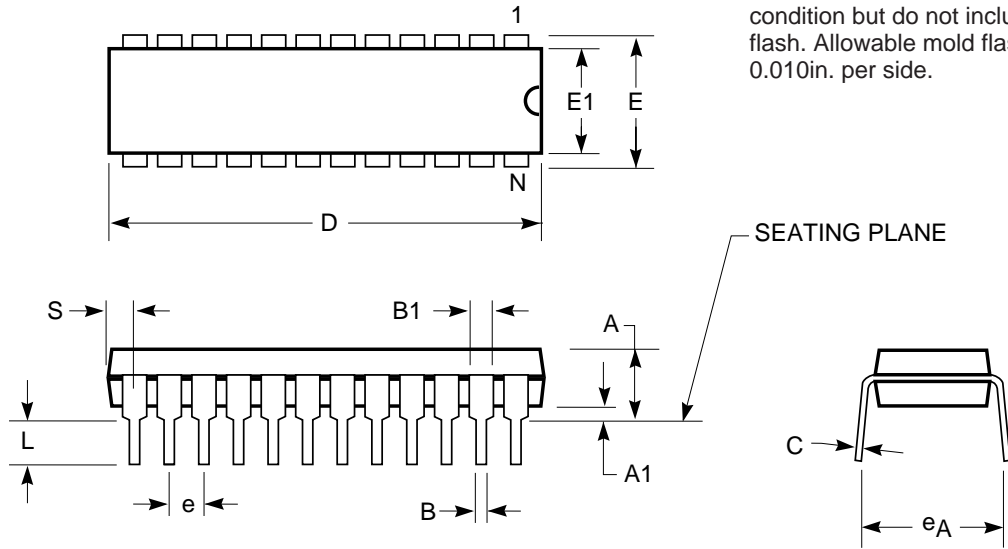

JEDEC#	MS-001AC		MS001AA		MS-001AE		N/A		MS-001AF		MO-095AH	
DWG#	PD14A		PD16A		PD20A		PT22B		PT24A		PT28A	
Symbol	Min	Max	Min	Max	Min	Max	Min	Max	Min	Max	Min	Max
A	0.130	0.170	0.130	0.170	0.130	0.170	0.130	0.170	0.130	0.170	0.130	0.180
A1	0.015	0.040	0.015	0.040	0.015	0.040	0.015	0.040	0.015	0.040	0.015	0.040
B	0.016	0.020	0.016	0.020	0.016	0.020	0.016	0.020	0.016	0.020	0.016	0.020
B1	0.045	0.070	0.045	0.070	0.045	0.070	0.045	0.070	0.045	0.070	0.045	0.060
C	0.009	0.012	0.009	0.012	0.009	0.012	0.009	0.012	0.009	0.012	0.009	0.012
D	0.745	0.765	0.745	0.765	1.020	1.040	1.020	1.040	1.150	1.260	1.345	1.385
E	0.300	0.325	0.300	0.325	0.300	0.325	0.300	0.325	0.300	0.325	0.300	0.325
E1	0.240	0.270	0.240	0.270	0.240	0.270	0.240	0.270	0.250	0.280	0.275	0.295
e	0.090	0.110	0.090	0.110	0.090	0.110	0.090	0.110	0.090	0.110	0.090	0.110
e _A	0.310	0.380	0.310	0.380	0.310	0.380	0.310	0.380	0.310	0.380	0.310	0.380
L	0.120	0.140	0.120	0.140	0.120	0.140	0.120	0.140	0.120	0.140	0.120	0.140
S	0.070	0.080	0.020	0.035	0.060	0.070	0.010	0.020	0.025	0.080	0.020	0.040
N	14		16		20		22		24		28	

150-MIL QSOP - Package Code Q

Quarter-Size Outline Package
Plastic Small Outline Gull-Wing

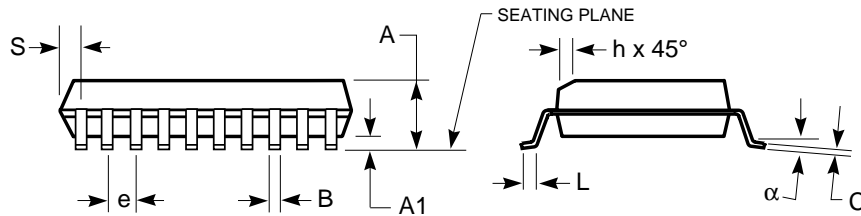
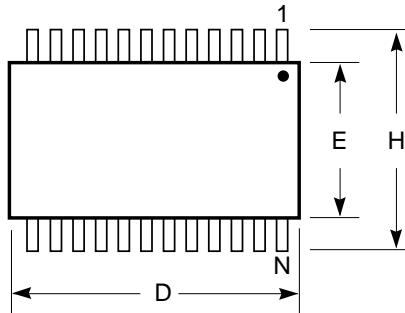

Notes:

1. Refer to applicable symbol list.
2. All dimensions are in inches.
3. N is the number of lead positions.
4. Dimensions D and E are to be measured at maximum material condition but do not include mold flash. Allowable mold flash is 0.006in. per side.
5. Lead coplanarity is 0.004in. maximum.

JEDEC#	MO-137AB			MO-137AD			MO-137AE			MO-137AF		
DWG#	PSS-16A			PSS-20A			PSS-24A			PSS-28A		
Symbol	Min	Nom	Max	Min	Nom	Max	Min	Nom	Max	Min	Nom	Max
A	0.060	0.064	0.068	0.060	0.064	0.068	0.060	0.064	0.068	0.060	0.064	0.068
A1	0.004	0.006	0.008	0.004	0.006	0.008	0.004	0.006	0.008	0.004	0.006	0.008
B	0.009	0.010	0.012	0.009	0.010	0.012	0.009	0.010	0.012	0.009	0.010	0.012
C	0.007	0.008	0.010	0.007	0.008	0.010	0.007	0.008	0.010	0.007	0.008	0.010
D	0.189	0.193	0.197	0.337	0.341	0.344	0.337	0.341	0.344	0.386	0.390	0.394
E	0.150	0.154	0.157	0.150	0.154	0.157	0.150	0.154	0.157	0.150	0.154	0.157
e	0.025 BSC			0.025 BSC			0.025 BSC			0.025 BSC		
H	0.230	0.236	0.244	0.230	0.236	0.244	0.230	0.236	0.244	0.230	0.236	0.244
h	0.010	0.013	0.016	0.010	0.013	0.016	0.010	0.013	0.016	0.010	0.013	0.016
L	0.016	0.025	0.035	0.016	0.025	0.035	0.016	0.025	0.035	0.016	0.025	0.035
N	16			20			24			28		
alpha	0°	5°	8°	0°	5°	8°	0°	5°	8°	0°	5°	8°
S	0.006	0.009	0.010	0.056	0.058	0.060	0.031	0.033	0.035	0.031	0.033	0.035