

PQ20VZ51/PQ20VZ11

Variable Output, Surface Mount Type Low Power-Loss Voltage Regulators

■ Features

- Low power-loss (Dropout voltage : 0.5V)
- Compact surface mount package
- Both the 0.5A output PQ20VZ51 and the 1A output PQ20VZ11 have high-precision outputs (Reference voltage precision : $\pm 2.0\%$)
- Variable output type (Output voltage variable range : 1.5V to 20V)
- Built-in ON-OFF control function
- Low dissipation current at OFF-state (I_{qs} : MAX.5 μ A)
- Tape packaged type is available.
($\phi 330$ mm reel : 3 000pcs.,PQ20VZ5U/PQ20VZ1U)

■ Applications

- Car audio equipment
- VCR

■ Outline Dimensions

(Unit : mm)

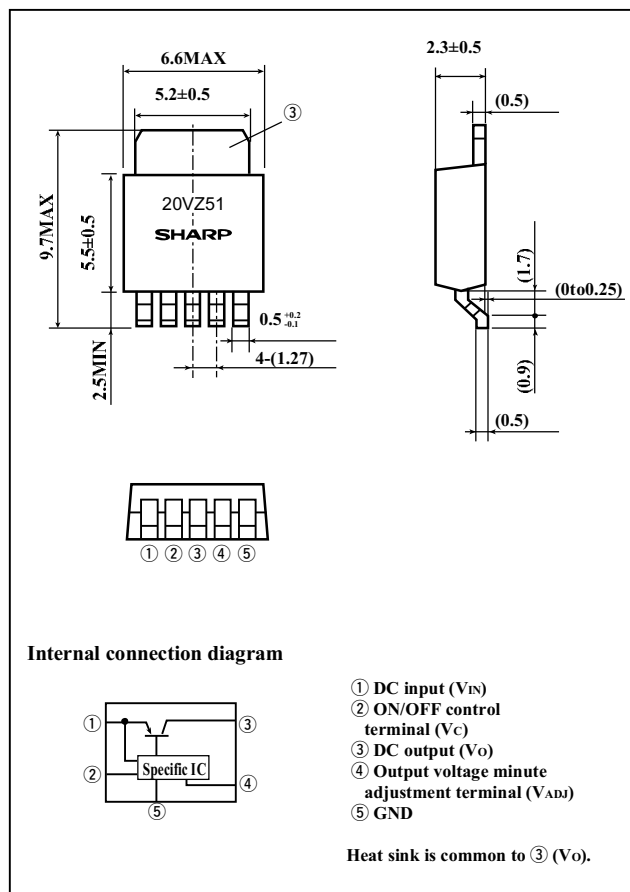

■ Absolute Maximum Ratings

($T_a=25^\circ\text{C}$)

Parameter	Symbol	Rating	Unit
*1 Input voltage	V_{IN}	24	V
*1 Output control voltage	V_C	24	V
*1 Output adjustment terminal Voltage	V_{ADJ}	7	V
Output current	PQ20VZ51	0.5	A
	PQ20VZ11	1	
Power dissipation (With infinite heat sink)	P_D	8	W
*2 Junction temperature	T_j	150	$^\circ\text{C}$
Operating temperature	T_{opr}	-20 to +80	$^\circ\text{C}$
Storage temperature	T_{stg}	-40 to +150	$^\circ\text{C}$
*3 Soldering temperature	T_{sol}	260 (For 10s)	$^\circ\text{C}$

*1 All are open except GND and applicable terminals.

*2 Overheat protection may operate at $125^\circ\text{C} < T_j < 150^\circ\text{C}$

*3 For 10s

· Please refer to the chapter "Handling Precautions".

SHARP

"In the absence of confirmation by device specification sheets, SHARP takes no responsibility for any defects that may occur in equipment using any SHARP devices shown in catalogs, data books, etc. Contact SHARP in order to obtain the latest version of the device specification sheets before using any SHARP's device."

■ Electrical Characteristics

Unless otherwise specified, $V_{IN}=12V$, $V_O=10V$,^{*4}, $R_1=1k\Omega$, $V_C=2.7V(T_a=25^\circ C)$

Parameter	Symbol	Conditions	MIN.	TYP.	MAX.	Unit
Input voltage	V_i	$V_O=1.5V$	4.5	-	-	V
Output voltage	V_O	$R_2=225\Omega$ to $14.6k\Omega$	1.5	-	20	V
Load regulation	R_{egL}	^{*5}	-	0.2	2.0	%
Line regulation	R_{egI}	$V_{IN}=11$ to $21V$, $I_O=5mA$	-	0.2	2.5	%
Ripple rejection	RR	Refer to Fig. 2	45	60	-	dB
Reference voltage	V_{ref}	^{*4}	1.225	1.25	1.275	V
Temperature coefficient of reference voltage	$T_C V_{ref}$	$T_j=0$ to $125^\circ C$, $I_O=5mA$	-	± 1.0	-	%
Dropout voltage	V_{i-O}	^{*4, *6}	-	0.2	0.5	V
Quiescent current	I_q	$I_O=0$	-	4	7	mA
ON-state voltage for control	$V_C(ON)$	-	2.0	-	-	V
ON-state current for control	$I_C(ON)$	-	-	-	200	μA
OFF-state voltage for control	$V_C(OFF)$	$I_O=0$	-	-	0.8	V
OFF-state current for control	$I_C(OFF)$	-	-	-	2.0	μA
Output OFF-state consumption current	I_{qs}	$V_C=0.4V$	-	-	5.0	μA

^{*4} PQ20VZ51: $I_O=0.3A$, PQ20VZ11: $I_O=0.5A$

^{*5} PQ20VZ51: $I_O=5mA$ to $0.5A$, PQ20VZ11: $I_O=5mA$ to $1.0A$

^{*6} Input voltage shall be the value when output voltage is 95% in comparison with the initial value.

^{*7} In case of opening control terminal ②, output voltage turns off.

Fig.1 Test Circuit

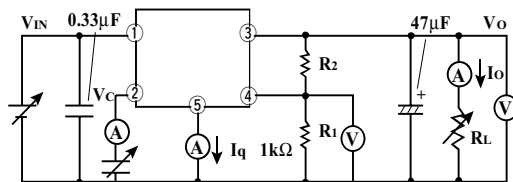

$$V_O = V_{ref} \times \left(1 + \frac{R_2}{R_1} \right) \approx 1.25 \times \left(1 + \frac{R_2}{R_1} \right)$$

[$R_1=1k\Omega, V_{ref} \approx 1.25V$]

Fig.2 Test Circuit of Ripple Rejection

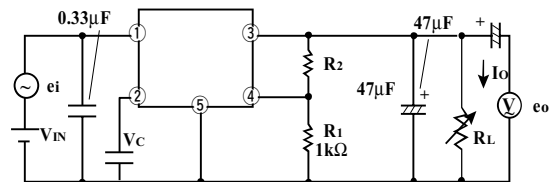

$f=120Hz$ (sine wave)
 $e_i=0.5V_{rms}$
 $I_O=0.3A$
 $RR=20 \log(e_i/e_o)$

Fig.3 Power Dissipation vs. Ambient Temperature

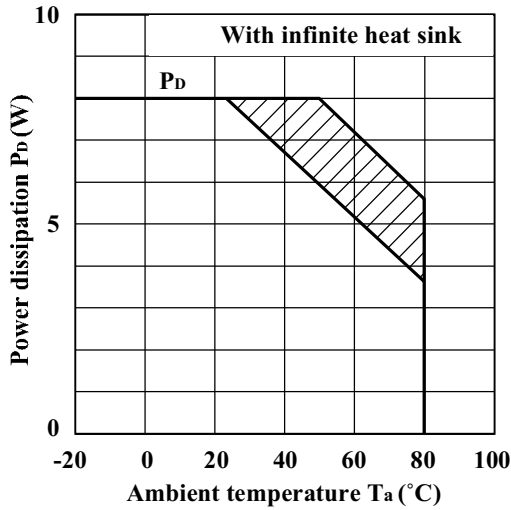

Note) Oblique line portion : Overheat protection may operate in this area.

Fig.4 Overcurrent Protection Characteristics (Typical Value)

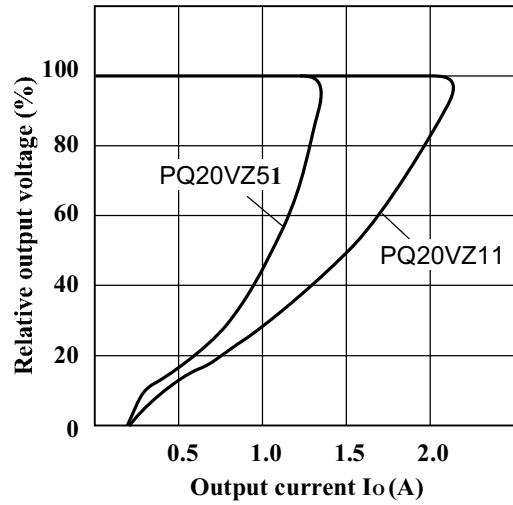

Fig.5 Output Voltage Adjustment Characteristics

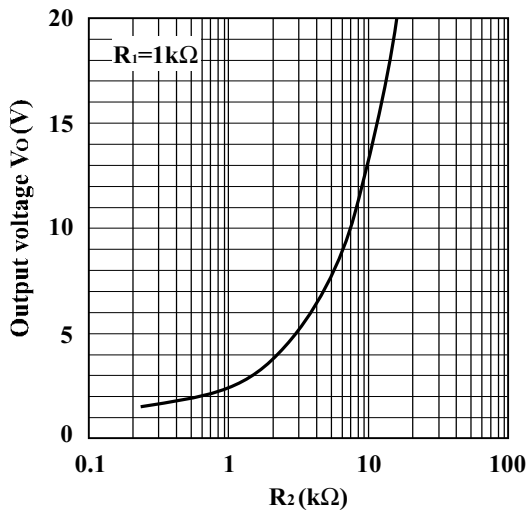

Fig.6 Reference Voltage Deviation vs. Junction Temperature

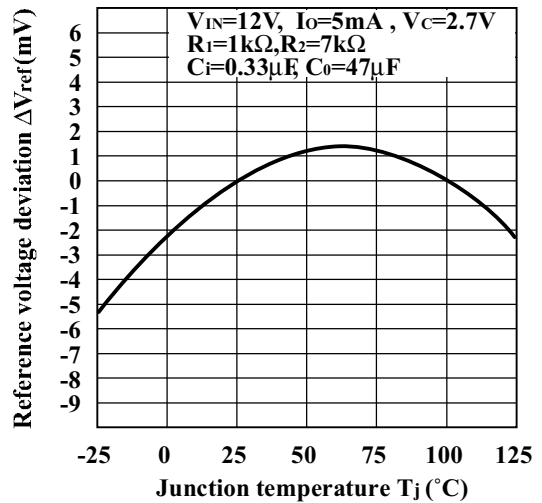

Fig.7 Output Voltage vs. Input Voltage (PQ20VZ51)

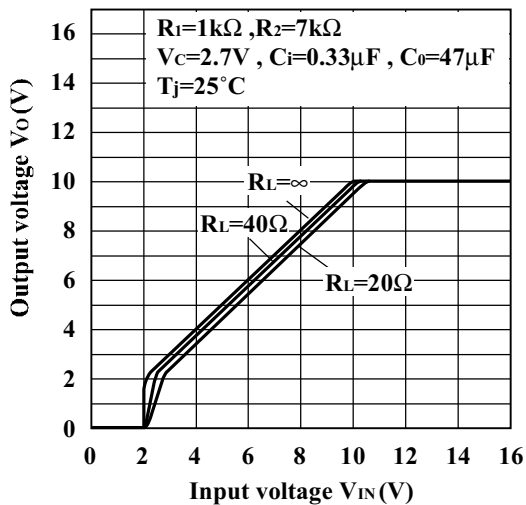

Fig.8 Output Voltage vs. Input Voltage (PQ20VZ11)

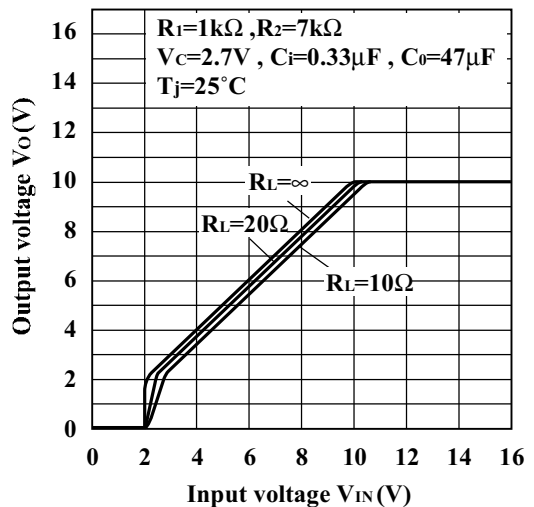

Fig.9 Dropout Voltage vs. Junction Temperature (PQ20VZ51)

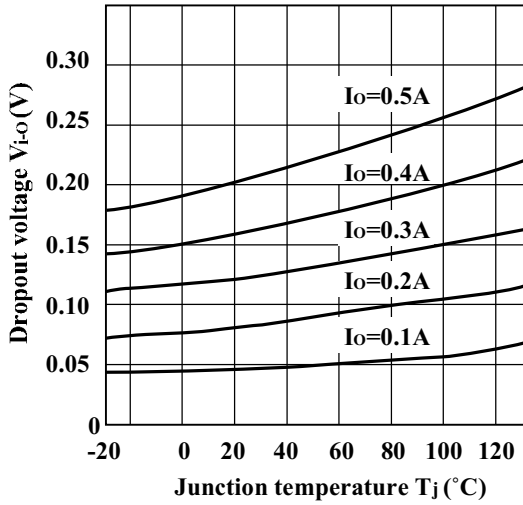

Fig.10 Dropout Voltage vs. Junction Temperature (PQ20VZ11)

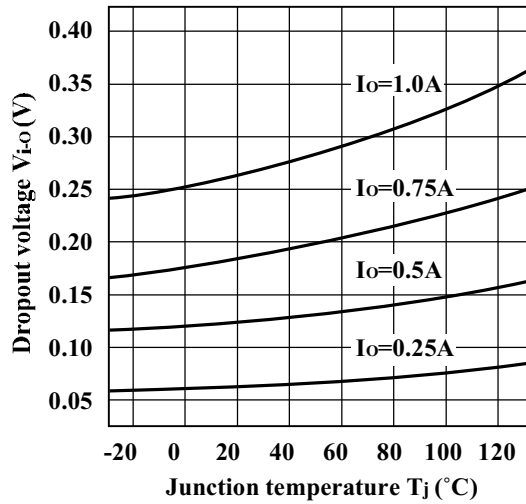

Fig.11 Quiescent Current vs. Junction Temperature

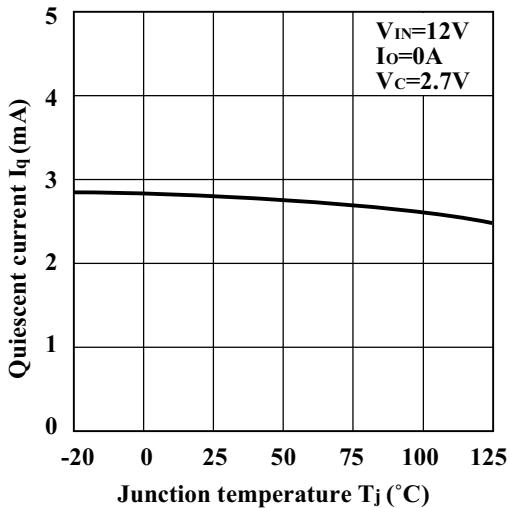

Fig.12 Ripple Rejection vs. Input Ripple Frequency

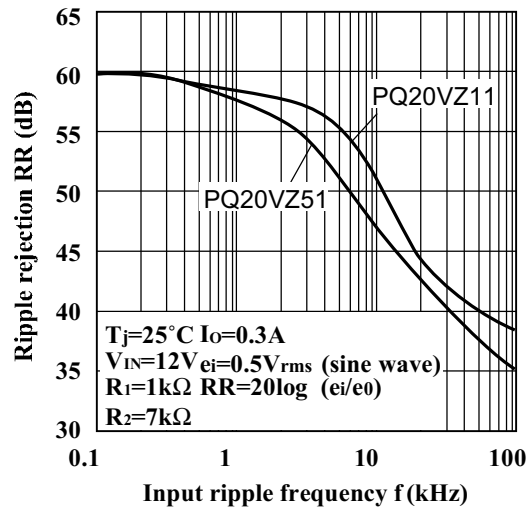

Fig.13 Ripple Rejection vs. Output Current (PQ20VZ51)

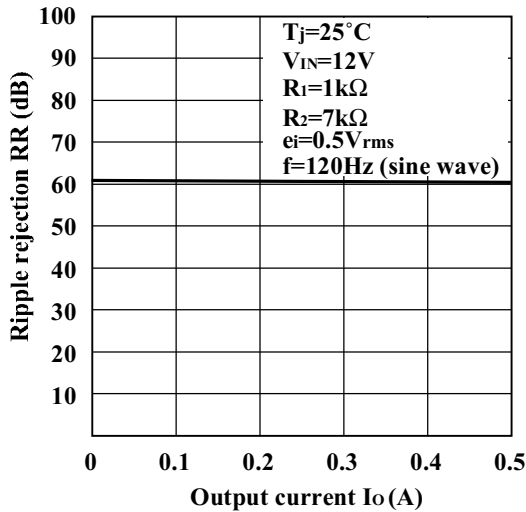

Fig.14 Ripple Rejection vs. Output Current (PQ20VZ11)

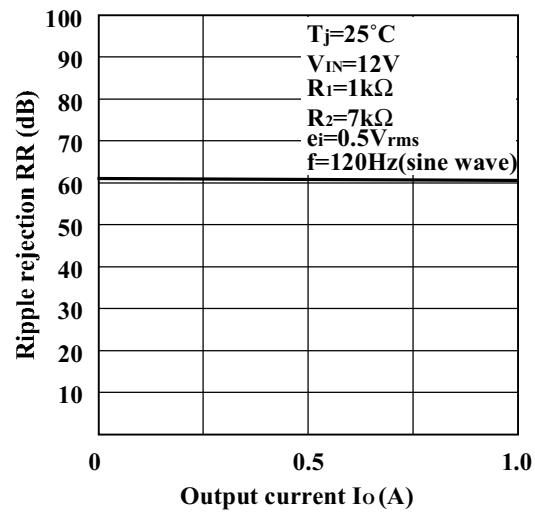

Fig.15 Output Peak Current vs. Dropout Voltage (PQ20VZ51)

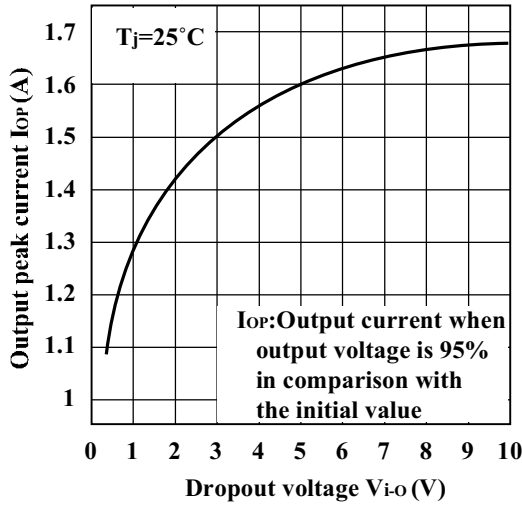

Fig.16 Output Peak Current vs. Dropout Voltage (PQ20VZ11)

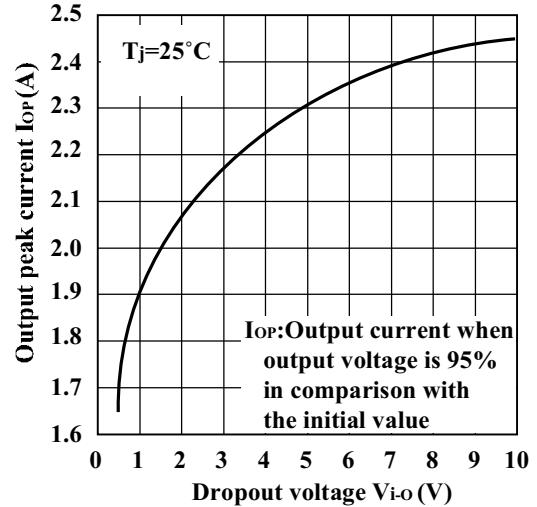

Fig.17 Output Peak Current vs. Junction Temperature (PQ20VZ51)

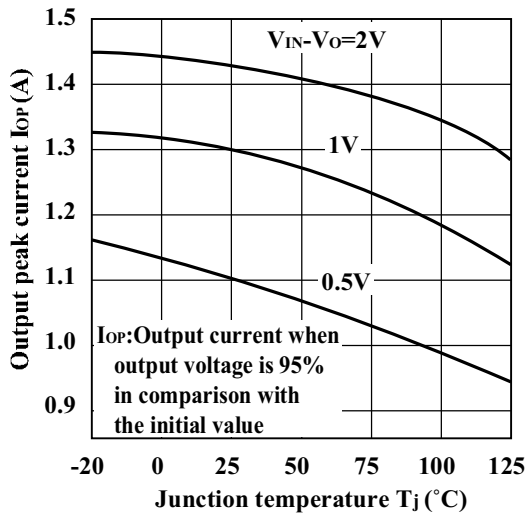

Fig.18 Output Peak Current vs. Junction Temperature (PQ20VZ11)

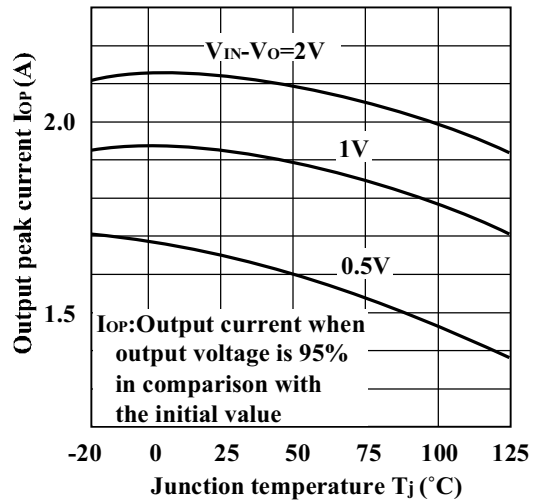
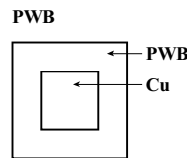
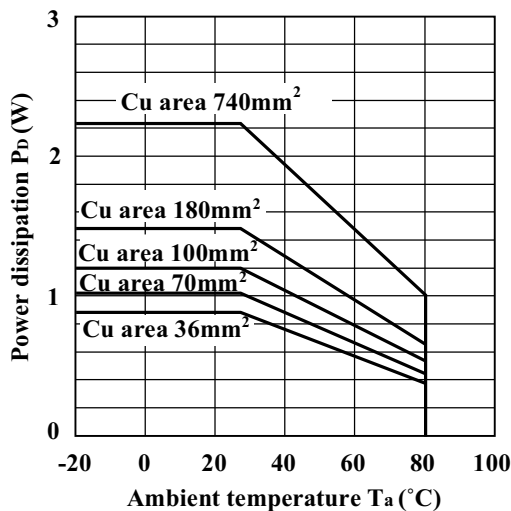

Fig.19 Power Dissipation vs. Ambient Temperature



Material : Glass-cloth epoxy resin
 Size : $50 \times 50 \times 1.6\text{mm}^3$
 Cu thickness : $35\mu\text{m}$

■ Adjustment of Output Voltage

Output voltage is able to be set from 1.5V to 20V when resistors R1,R2 are attached to ③,④,∞ terminals. As for the external resistors to set output voltage, refer to the following figure or Fig.5.

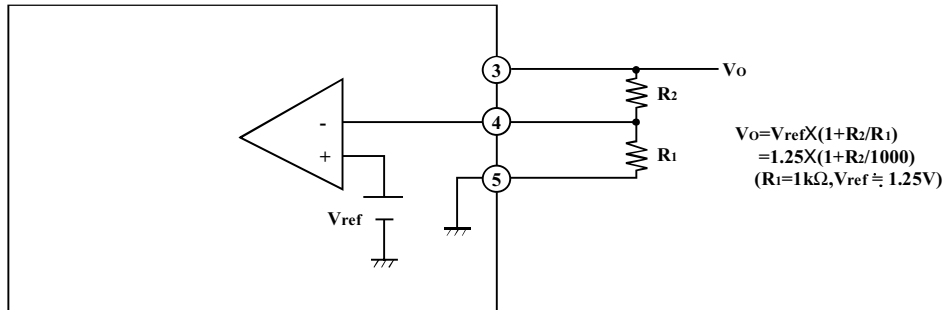

■ ON/OFF Operation

As shown in the figure, ON/OFF control function is available.

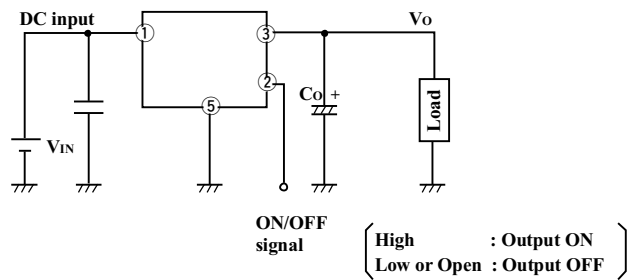

■ Model Line-ups for Tape-packaged Products

Output current	Sleeve-packaged products		Tape-packaged products	
	Standard type	High-precision output type	Standard type	High-precision output type
0.5A output	-	PQ20VZ51	-	PQ20VZ5U
1.0A output	-	PQ20VZ11	-	PQ20VZ1U