PF0146

MOS FET Power Amplifier Module for GSM Handy Phone

HITACHI

ADE-208-285C (Z)
4th. Edition
July 1996

Application

For GSM class4 890 to 915 MHz

Features

- Small package: 1 cc, 3g
- High efficiency: 50% Typ
- High speed switching: 0.9 μ sec

Pin Arrangement

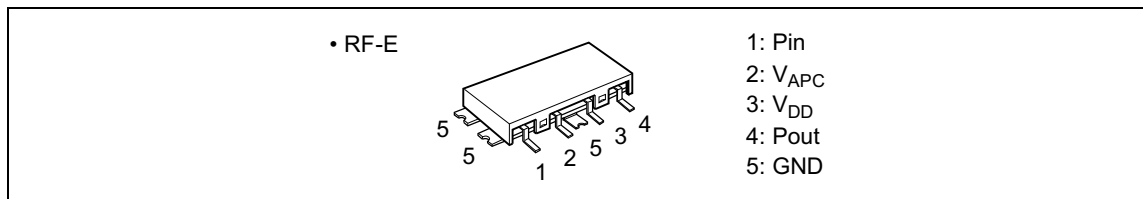

PF0146

Internal Diagram and External Condition at Classification

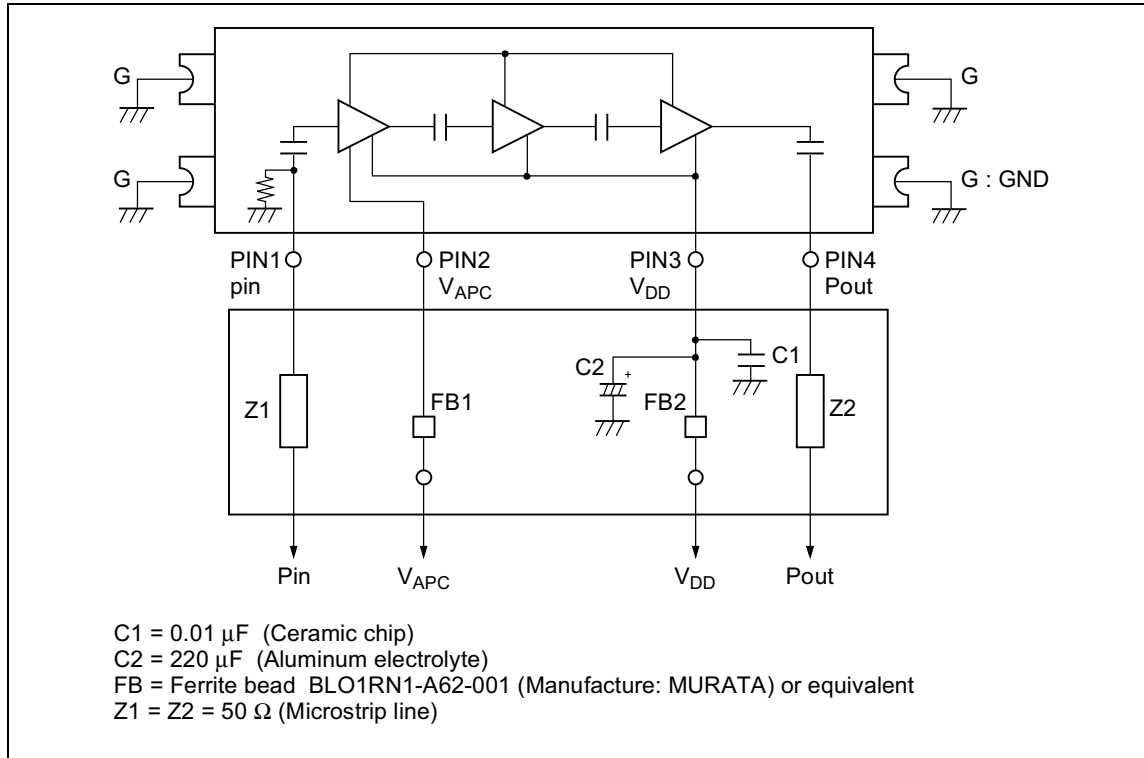

Absolute Maximum Ratings ($T_c = 25^\circ\text{C}$)

Item	Symbol	Rating	Unit
Supply voltage	V _{DD}	10	V
Supply current	I _{DD}	3	A
APC voltage	V _{APC}	6	V
Input power	P _{in}	20	mW
Operating case temperature	T _{c (op)}	-30 to +100	$^\circ\text{C}$
Storage temperature	T _{stg}	-30 to +100	$^\circ\text{C}$
Output power	P _{out}	7	W

Electrical Characteristics (Tc = 25°C)

Item	Symbol	Min	Typ	Max	Unit	Test Condition
Frequency range	f	890	—	915	MHz	—
Control voltage range	VAPC	0.5	—	4.0	V	—
Drain cutoff current	IDS	—	—	100	μA	VDD = 10 V, VAPC = 0 V
Total efficiency	ηT	45	50	—	%	Pin = 2mW, VDD = 6 V,
2nd harmonic distortion	2nd H.D.	—	-50	-35	dBc	Pout = 3.2 W (at APC controlled),
3rd harmonic distortion	3rd H.D.	—	-60	-45	dBc	RL = Rg = 50 Ω, Tc = 25°C
Input VSWR	VSWR (in)	—	2	3	—	
Output power (1)	Pout (1)	3.6	4.2	—	W	Pin = 2 mW, VDD = 6 V, VAPC = 4 V, RL = Rg = 50 Ω, Tc = 25°C
Output power (2)	Pout (2)	2.4	3.0	—	W	Pin = 2 mW, VDD = 5.4 V, VAPC = 4 V, RL = Rg = 50 Ω, Tc = 80°C
Isolation	—	—	-45	-40	dBm	Pin = 2 mW, VDD = 6 V, VAPC = 0.5 V, RL = Rg = 50 Ω, Tc = 25°C
Switching time	tr, tf	—	0.9	2	μs	Pin = 2 mW, VDD = 6 V, Pout = 3.2 W, RL = Rg = 50 Ω, Tc = 25°C
Stability	—	No parasitic oscillation			—	Pin = 2 mW, VDD = 7.5 V, Pout ≤ 3.2 W (at APC controlled), Rg = 50 Ω, Tc = 25°C, Output VSWR = 10:1 All phases

Test System Diagram

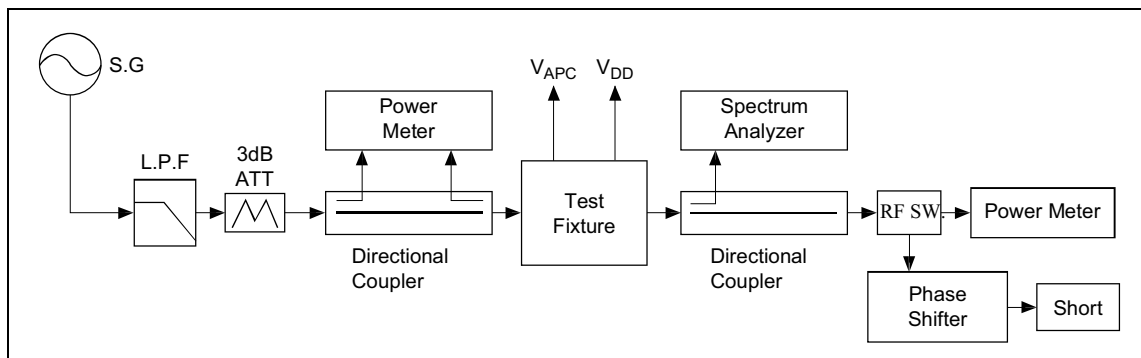

PF0146

Switching Time Test Diagram

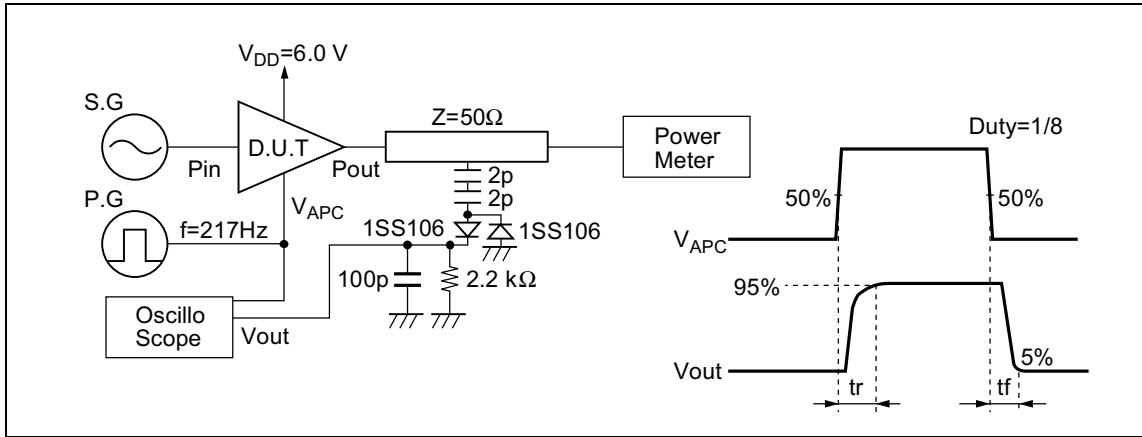

Test Fixture Pattern

Unit: mm

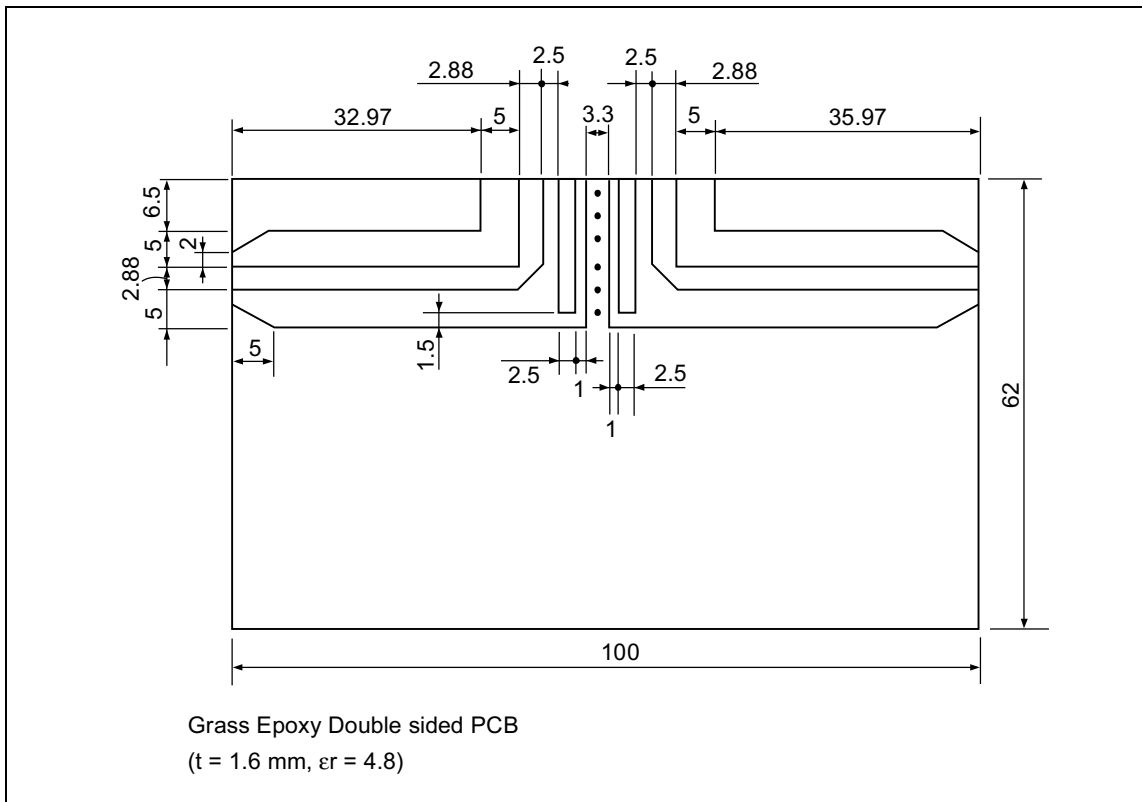

Note for Use

- Apply control voltage range as $V_{APC} = 0.5$ to 4.0 V, and GSM burst mode must be applied to all operation. For instance, pulse width = 0.577 msec., duty = 12.5% and $V_{APC} \leq 0.5$ V, for all 4.616 msec. Frame except for 0.577 msec. pulse.
- Unevenness and distortion at the surface of PCB mounted module should be as small as possible.
- To protect devices from electro-static damage, soldering iron, measuring equipment and human body, etc. should be grounded.
- To avoid the degradation of efficiency and output power, lead pins should not be floated from copper foil of PCB, and connected to right position of RF signal line (refer to figure 1)
- Recommendation to improve the thermal resistance is shown below.
 - Make through holes as many as possible under module.
 - Use heat sink on the top case of module.
- When the external components(Isolator, Duplexer, etc) of the module are changed, the electrical characteristics of total system should be evaluated enough.
- To avoid destruction of module caused by excess power consumption, voltage of APC should be limited less than 6 V.
- To get good stability, all GND pins should be soldered to ground pattern of PCB.
- Don't apply Full Heating Methods except Infrared Heating Methods.
- In case of Partial Heating Methods, soldering temperature and time should be less than 230°C , 10 sec, per each GND pin.
- Soldering temperature and time for I.R. Reflow should be the reflow profile shown in figure 2.
- Recommended conditions for Rising Methods shows as follows.
 - Solvents: de-ionized water, isopropyl alcohol, ethyl alcohol
 - Rising condition: in case of soak rising 5 min max, in case of ultrasonic rising 5 min max
- Don't apply dipping solder method to mount.
- Apply the way of washing after actual confirmation.
- Recommended pattern of footprint is shown in figure 3.

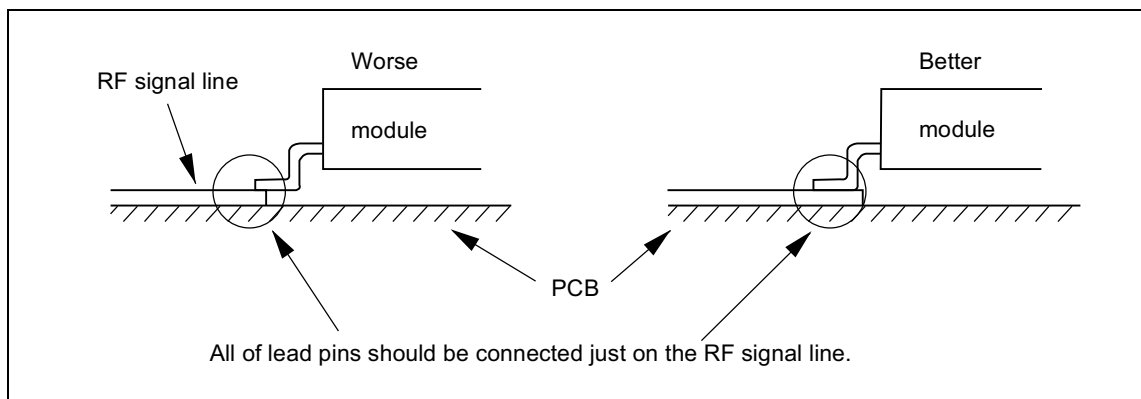

Figure 1

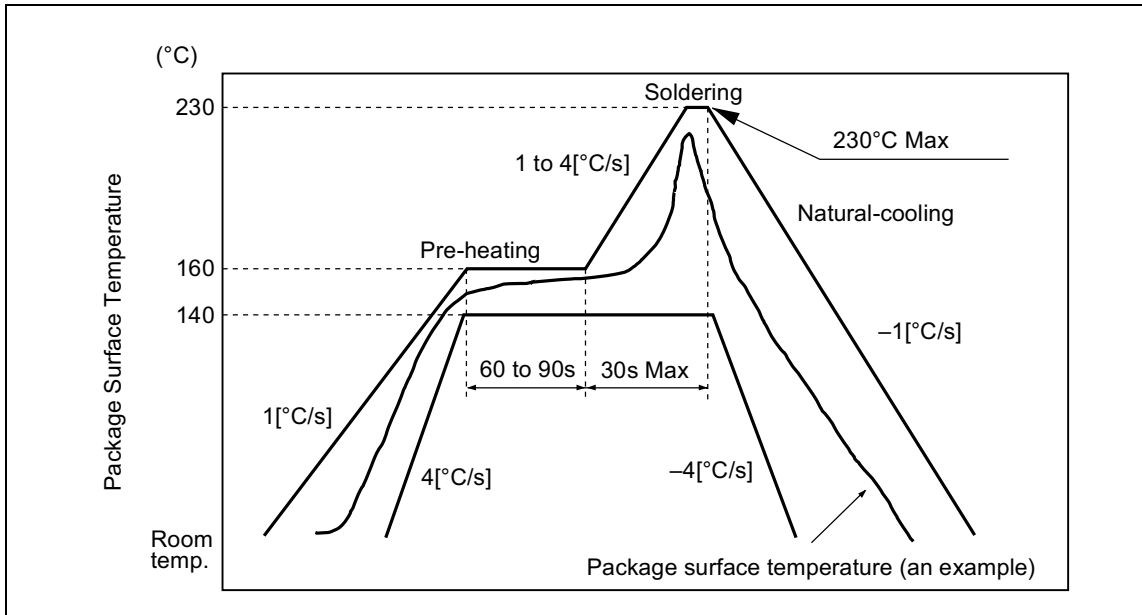

Figure 2

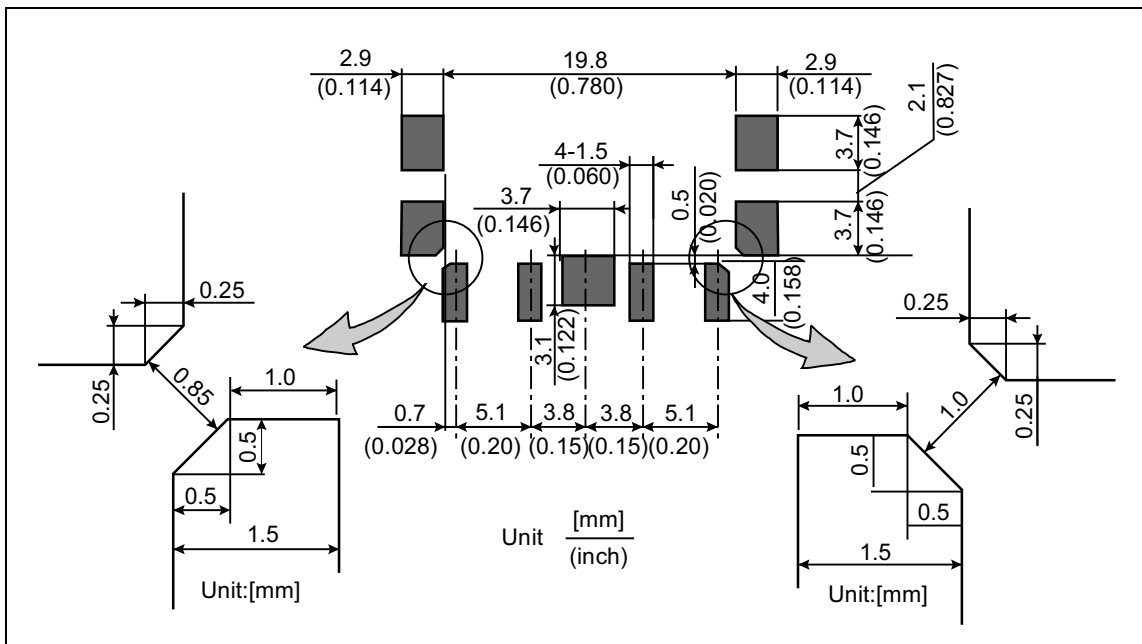
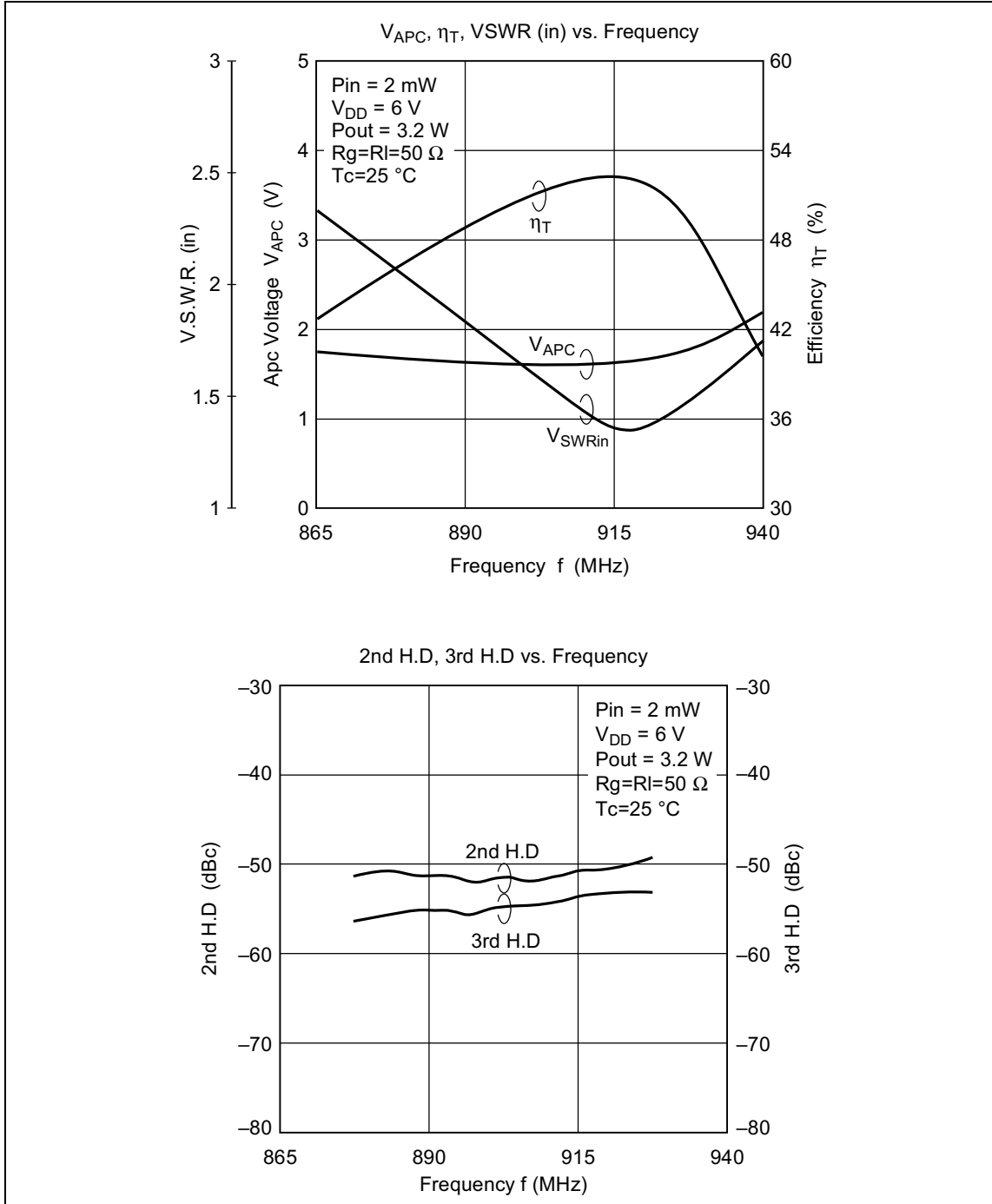

Figure 3

Characteristics Curve



PF0146

Pout, η_T vs. V_{APC} (1)

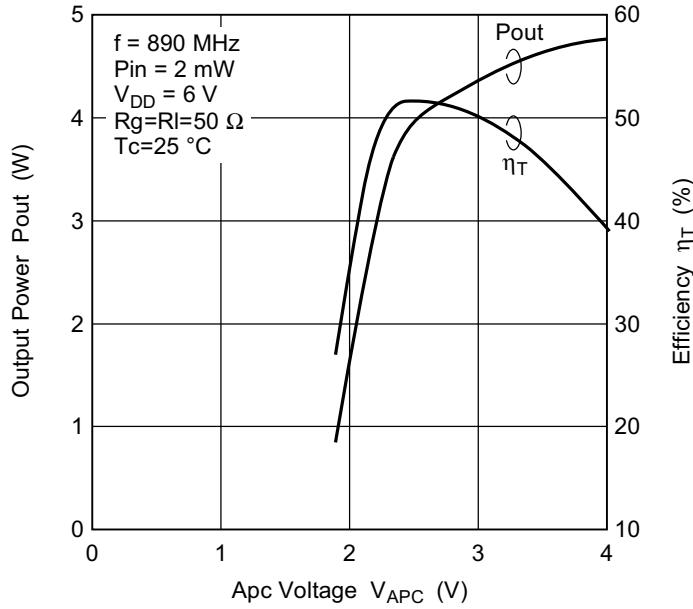

Pout, η_T vs. V_{APC} (2)

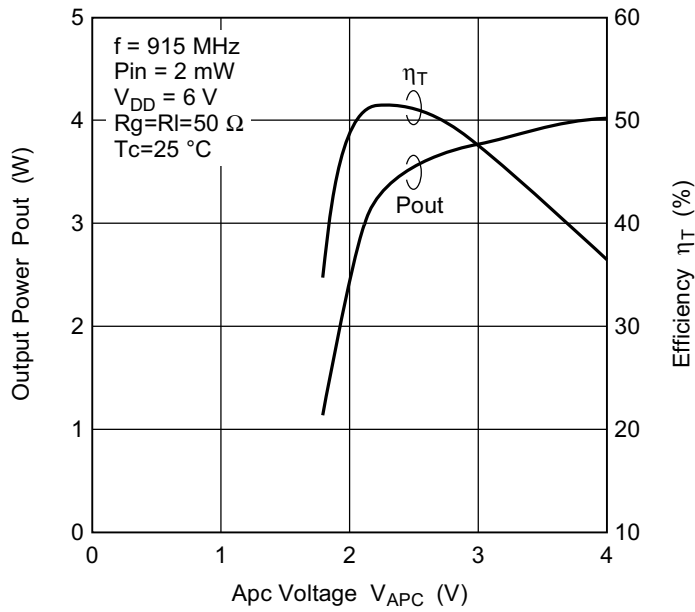

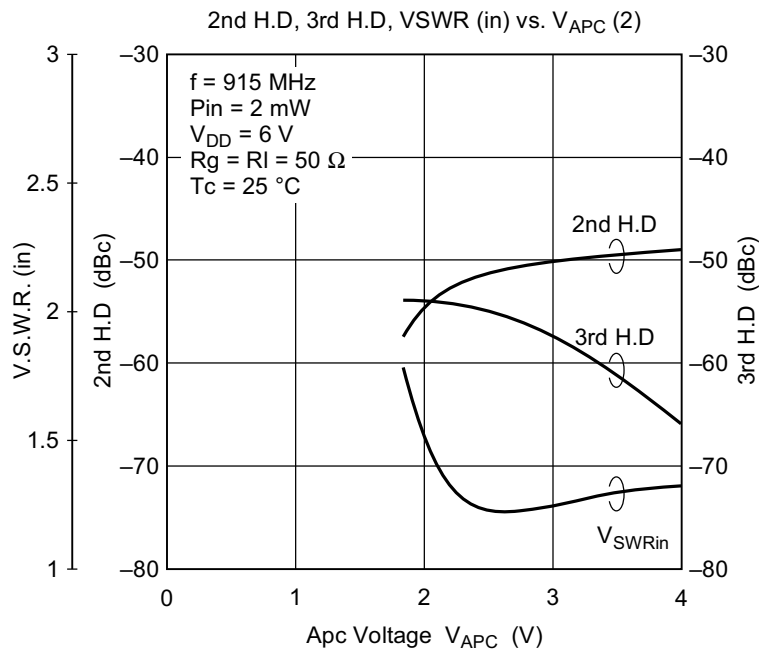
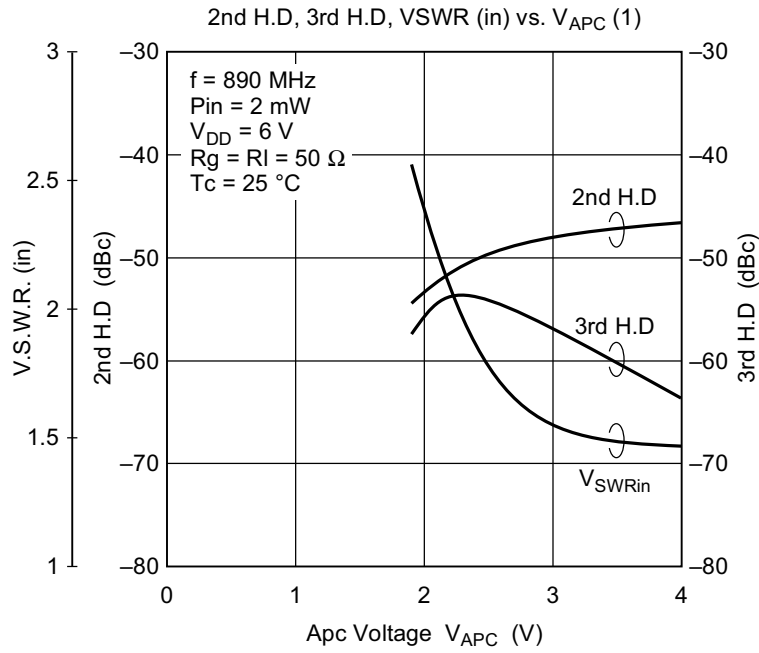

PF0146

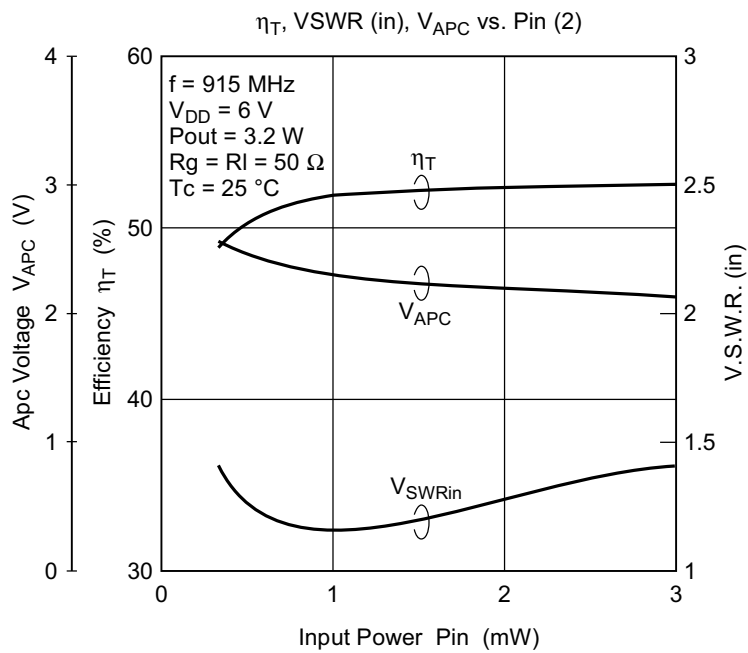
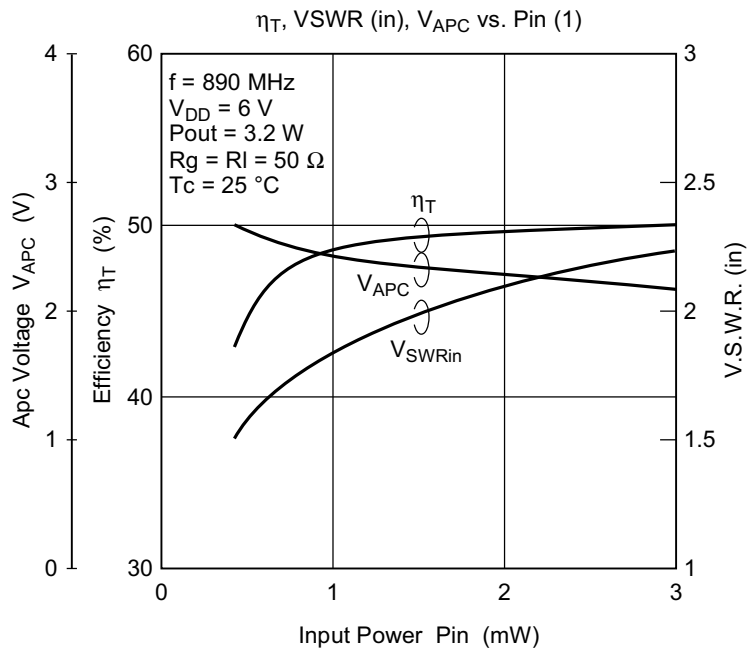

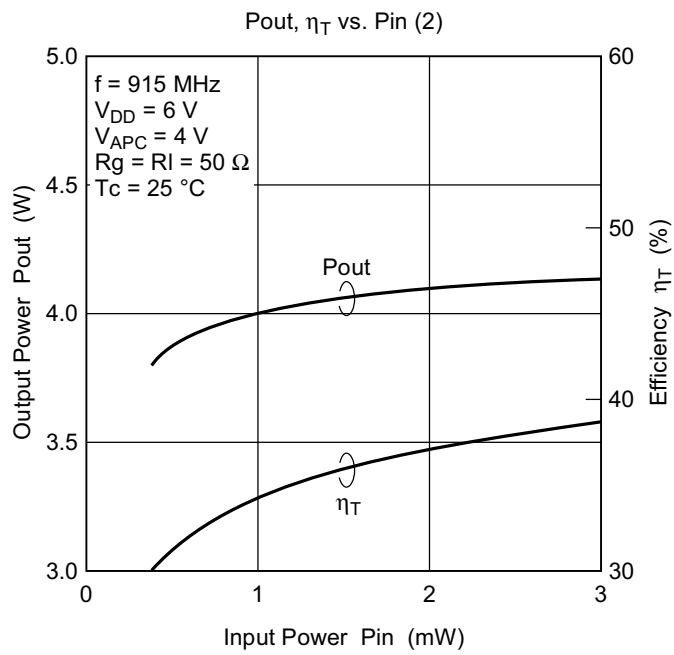
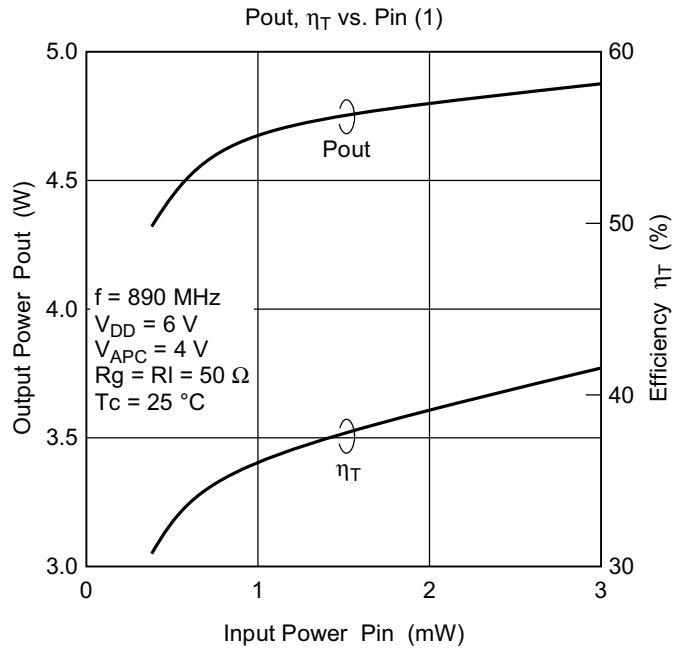

PF0146

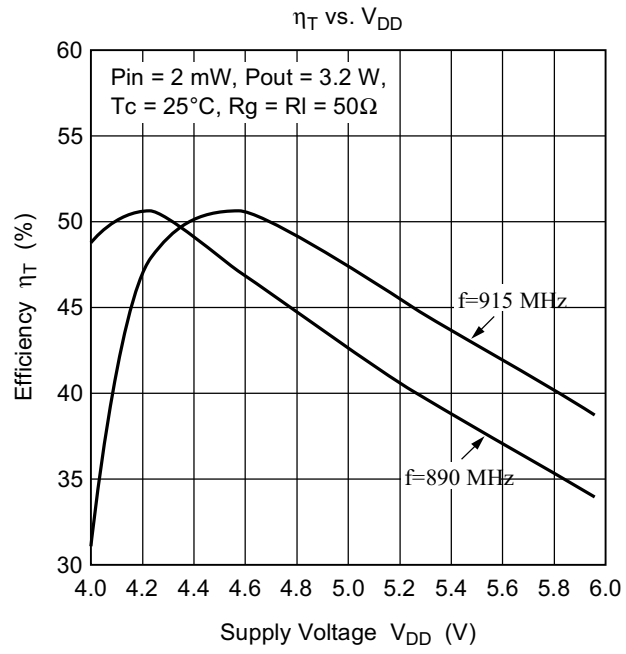

Package Dimensions

Unit: mm

