



PALCE22V10 and PALCE22V10Z Families

24-Pin EE CMOS (Zero Power) Versatile PAL Device

DISTINCTIVE CHARACTERISTICS

- ◆ As fast as 5-ns propagation delay and 142.8 MHz f_{MAX} (external)
- ◆ Low-power EE CMOS
- ◆ 10 macrocells programmable as registered or combinatorial, and active high or active low to match application needs
- ◆ Varied product term distribution allows up to 16 product terms per output for complex functions
- ◆ Peripheral Component Interconnect (PCI) compliant (-5/-7/-10)
- ◆ Global asynchronous reset and synchronous preset for initialization
- ◆ Power-up reset for initialization and register preload for testability
- ◆ Extensive third-party software and programmer support
- ◆ 24-pin SKINNY DIP, 24-pin SOIC, and 28-pin PLCC
- ◆ 5-ns and 7.5-ns versions utilize split leadframes for improved performance

GENERAL DESCRIPTION

The PALCE22V10 provides user-programmable logic for replacing conventional SSI/MSI gates and flip-flops at a reduced chip count.

The PALCE22V10Z is an advanced PAL[®] device built with zero-power, high-speed, electrically-erasable CMOS technology. It provides user-programmable logic for replacing conventional zero-power CMOS SSI/MSI gates and flip-flops at a reduced chip count.

The PALCE22V10Z provides zero standby power and high speed. At 30 μ A maximum standby current, the PALCE22V10Z allows battery-powered operation for an extended period.

The PAL device implements the familiar Boolean logic transfer function, the sum of products. The PAL device is a programmable AND array driving a fixed OR array. The AND array is programmed to create custom product terms, while the OR array sums selected terms at the outputs.

The product terms are connected to the fixed OR array with a varied distribution from 8 to 16 across the outputs (see Block Diagram). The OR sum of the products feeds the output macrocell. Each macrocell can be programmed as registered or combinatorial, and active-high or active low. The output configuration is determined by two bits controlling two multiplexers in each macrocell.

BLOCK DIAGRAM

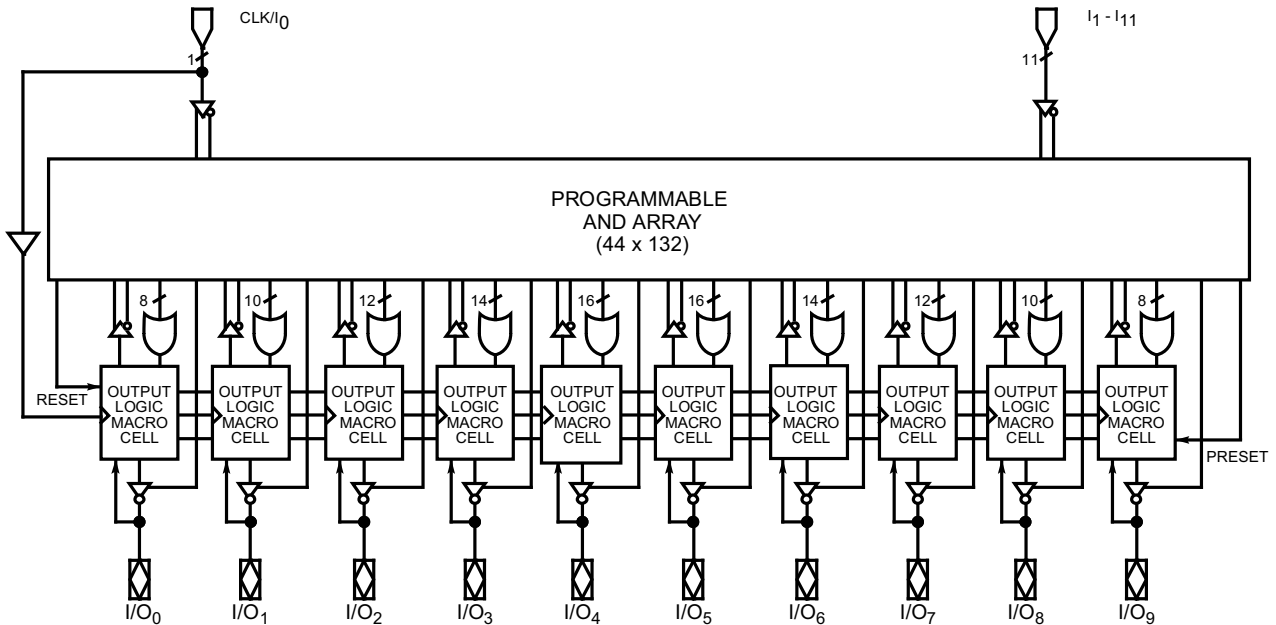

FUNCTIONAL DESCRIPTION

The PALCE22V10 allows the systems engineer to implement the design on-chip, by programming EE cells to configure AND and OR gates within the device, according to the desired logic function. Complex interconnections between gates, which previously required time-consuming layout, are lifted from the PC board and placed on silicon, where they can be easily modified during prototyping or production.

The PALCE22V10Z is the zero-power version of the PALCE22V10. It has all the architectural features of the PALCE22V10. In addition, the PALCE22V10Z has zero standby power and unused product term disable.

Product terms with all connections opened assume the logical HIGH state; product terms connected to both true and complement of any single input assume the logical LOW state.

The PALCE22V10 has 12 inputs and 10 I/O macrocells. The macrocell (Figure 1) allows one of four potential output configurations registered output or combinatorial I/O, active high or active low (see Figure 1). The configuration choice is made according to the user's design specification and corresponding programming of the configuration bits $S_0 - S_1$. Multiplexer controls are connected to ground (0) through a programmable bit, selecting the "0" path through the multiplexer. Erasing the bit disconnects the control line from GND and it is driven to a high level, selecting the "1" path.

The device is produced with an EE cell link at each input to the AND gate array, and connections may be selectively removed by applying appropriate voltages to the circuit. Utilizing an easily-implemented programming algorithm, these products can be rapidly programmed to any customized pattern.

Variable Input/Output Pin Ratio

The PALCE22V10 has twelve dedicated input lines, and each macrocell output can be an I/O pin. Buffers for device inputs have complementary outputs to provide user-programmable input signal polarity. Unused input pins should be tied to V_{CC} or GND.

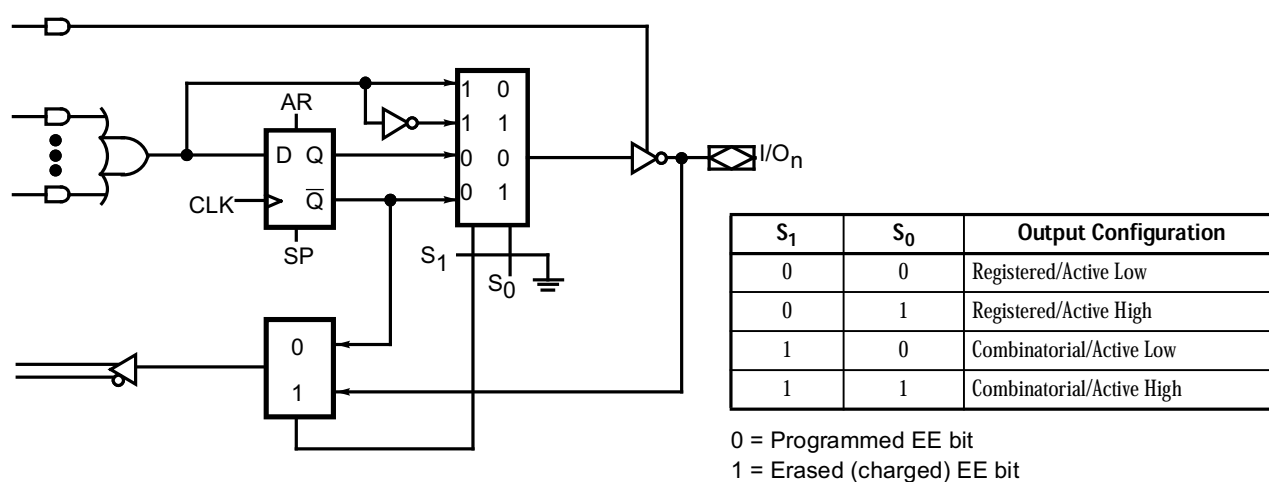

16564E-004

Figure 1. Output Logic Macrocell Diagram

Registered Output Configuration

Each macrocell of the PALCE22V10 includes a D-type flip-flop for data storage and synchronization. The flip-flop is loaded on the LOW-to-HIGH transition of the clock input. In the registered configuration ($S_1 = 0$), the array feedback is from \overline{Q} of the flip-flop.

Combinatorial I/O Configuration

Any macrocell can be configured as combinatorial by selecting the multiplexer path that bypasses the flip-flop ($S_1 = 1$). In the combinatorial configuration, the feedback is from the pin.

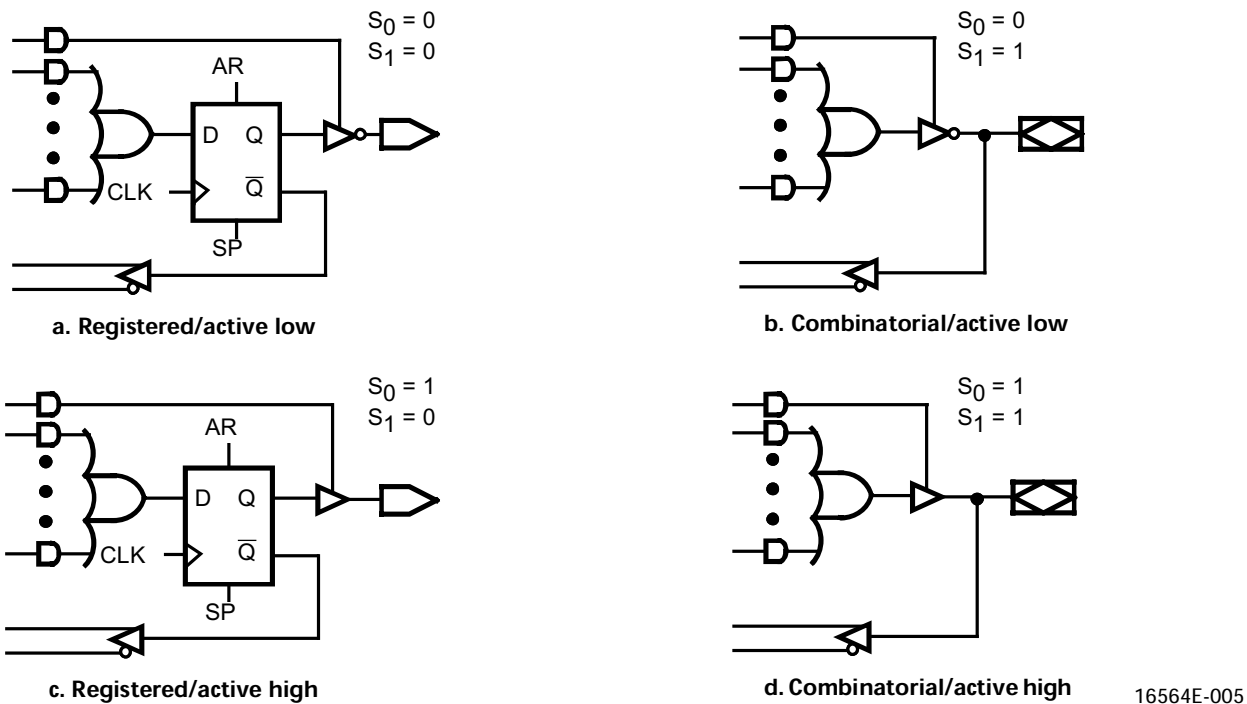

Figure 2. Macrocell Configuration Options

Programmable Three-State Outputs

Each output has a three-state output buffer with three-state control. A product term controls the buffer, allowing enable and disable to be a function of any product of device inputs or output feedback. The combinatorial output provides a bi-directional I/O pin, and may be configured as a dedicated input if the buffer is always disabled.

Programmable Output Polarity

The polarity of each macrocell output can be active high or active low, either to match output signal needs or to reduce product terms. Programmable polarity allows Boolean expressions to be written in their most compact form (true or inverted), and the output can still be of the desired polarity. It can also save “DeMorganizing” efforts.

Selection is controlled by programmable bit S_0 in the output macrocell, and affects both registered and combinatorial outputs. Selection is automatic, based on the design specification and pin definitions. If the pin definition and output equation have the same polarity, the output is programmed to be active high ($S_0 = 1$).

Preset/Reset

For initialization, the PALCE22V10 has preset and reset product terms. These terms are connected to all registered outputs. When the synchronous preset (SP) product term is asserted high, the output registers will be loaded with a HIGH on the next LOW-to-HIGH clock transition. When the asynchronous reset (AR) product term is asserted high, the output registers will be immediately loaded with a LOW independent of the clock.

Note that preset and reset control the flip-flop, not the output pin. The output level is determined by the output polarity selected.

Power-Up Reset

All flip-flops power up to a logic LOW for predictable system initialization. Outputs of the PALCE22V10 will depend on the programmed output polarity. The V_{CC} rise must be monotonic, and the reset delay time is 1000ns maximum.

Register Preload

The register on the PALCE22V10 can be preloaded from the output pins to facilitate functional testing of complex state machine designs. This feature allows direct loading of arbitrary states, making it unnecessary to cycle through long test vector sequences to reach a desired state. In addition, transitions from illegal states can be verified by loading illegal states and observing proper recovery.

Security Bit

After programming and verification, a PALCE22V10 design can be secured by programming the security EE bit. Once programmed, this bit defeats readback of the internal programmed pattern by a device programmer, securing proprietary designs from competitors. When the security bit is programmed, the array will read as if every bit is erased, and preload will be disabled.

The bit can only be erased in conjunction with erasure of the entire pattern.

Programming and Erasing

The PALCE22V10 can be programmed on standard logic programmers. It also may be erased to reset a previously configured device back to its unprogrammed state. Erasure is automatically performed by the programming hardware. No special erase operation is required.

Quality and Testability

The PALCE22V10 offers a very high level of built-in quality. The erasability of the device provides a direct means of verifying performance of all AC and DC parameters. In addition, this verifies complete programmability and functionality of the device to provide the highest programming yields and post-programming functional yields in the industry.

Technology

The high-speed PALCE22V10 is fabricated with Vantis' advanced electrically erasable (EE) CMOS process. The array connections are formed with proven EE cells. Inputs and outputs are designed to be compatible with TTL devices. This technology provides strong input clamp diodes, output slew-rate control, and a grounded substrate for clean switching.

PCI Compliance

The PALCE22V10H devices in the -5/-7/-10 speed grades are fully compliant with the *PCI Local Bus Specification* published by the PCI Special Interest Group. The PALCE22V10H's predictable timing ensures compliance with the PCI AC specifications independent of the design.

Zero-Standby Power Mode

The PALCE22V10Z features a zero-standby power mode. When none of the inputs switch for an extended period (typically 50 ns), the PALCE22V10Z will go into standby mode, shutting down

most of its internal circuitry. The current will go to almost zero ($I_{CC} < 30 \mu\text{A}$). The outputs will maintain the states held before the device went into the standby mode.

When any input switches, the internal circuitry is fully enabled, and power consumption returns to normal. This feature results in considerable power savings for operation at low to medium frequencies. This saving is illustrated in the I_{CC} vs. frequency graph.

Product-Term Disable

On a programmed PALCE22V10Z, any product terms that are not used are disabled. Power is cut off from these product terms so that they do not draw current. As shown in the I_{CC} vs. frequency graph, product-term disabling results in considerable power savings. This saving is greater at the higher frequencies.

Further hints on minimizing power consumption can be found in a separate document entitled, *Minimizing Power Consumption with Zero-Power PLDs*.

LOGIC DIAGRAM

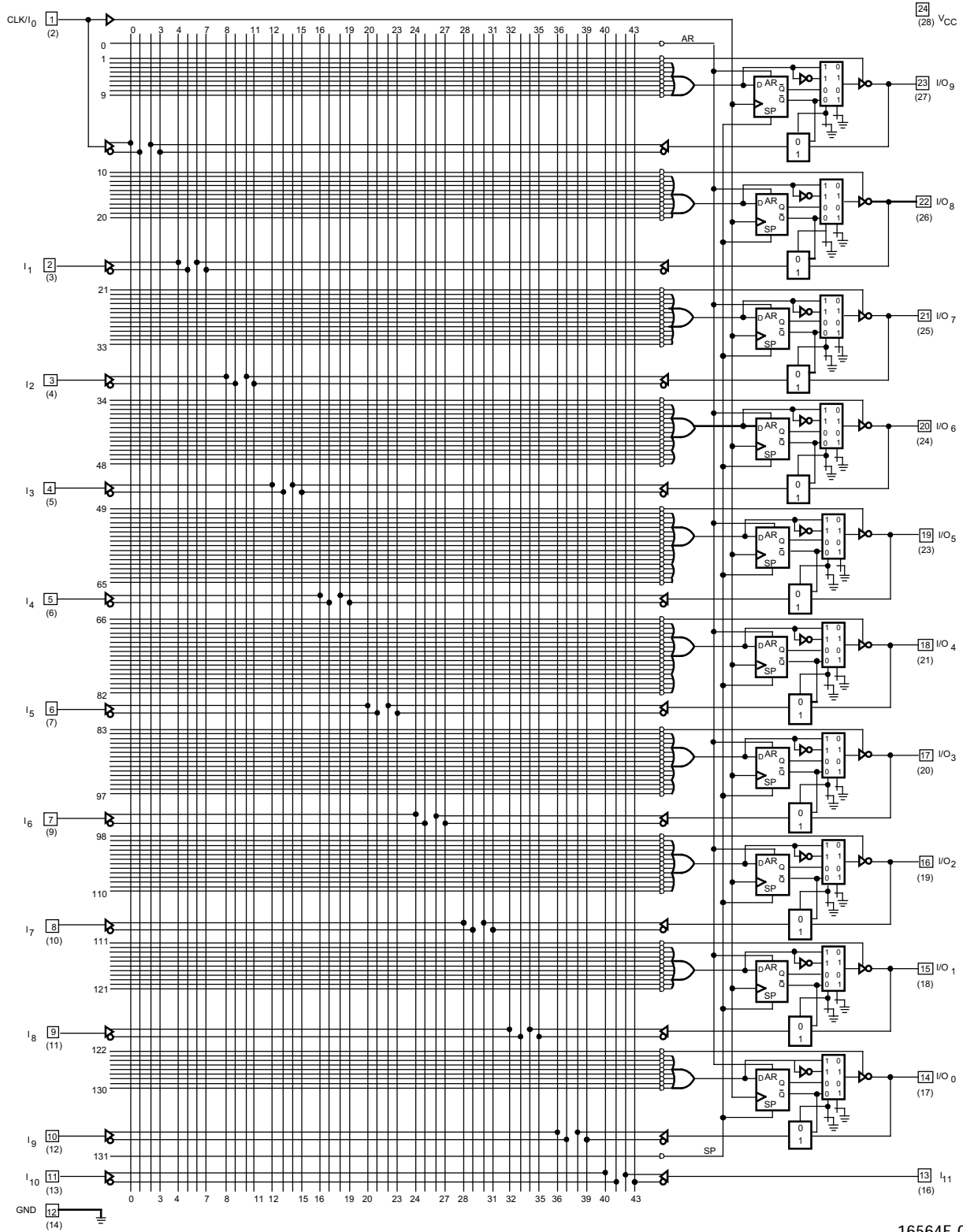

16564E-006

ABSOLUTE MAXIMUM RATINGS

Storage Temperature -65°C to +150°C
 Ambient Temperature with
 Power Applied -55°C to +125°C
 Supply Voltage with
 Respect to Ground -0.5 V to +7.0 V
 DC Input Voltage -0.5 V to $V_{CC} + 1.0$ V
 DC Output or I/O Pin Voltage . . . -0.5 V to $V_{CC} + 1.0$ V
 Static Discharge Voltage 2001 V
 Latchup Current ($T_A = 0^\circ\text{C}$ to $+75^\circ\text{C}$) 100 mA

Stresses above those listed under Absolute Maximum Ratings may cause permanent device failure. Functionality at or above these limits is not implied. Exposure to Absolute Maximum Ratings for extended periods may affect device reliability. Programming conditions may vary.

OPERATING RANGES

Commercial (C) Devices

Ambient Temperature (T_A)
 Operating in Free Air 0°C to $+75^\circ\text{C}$
 Supply Voltage (V_{CC}) with
 Respect to Ground +4.75 V to +5.25 V

Operating ranges define those limits between which the functionality of the device is guaranteed.

DC CHARACTERISTICS OVER COMMERCIAL OPERATING RANGES

Parameter Symbol	Parameter Description	Test Conditions	Min	Max	Unit
V_{OH}	Output HIGH Voltage	$I_{OH} = -3.2$ mA, $V_{IN} = V_{IH}$ or V_{IL} , $V_{CC} = \text{Min}$	2.4		V
V_{OL}	Output LOW Voltage	$I_{OL} = 16$ mA, $V_{IN} = V_{IH}$ or V_{IL} , $V_{CC} = \text{Min}$		0.4	V
V_{IH}	Input HIGH Voltage	Guaranteed Input Logical HIGH Voltage for all Inputs (Note 1)	2.0		V
V_{IL}	Input LOW Voltage	Guaranteed Input Logical LOW Voltage for all Inputs (Note 1)		0.8	V
I_{IH}	Input HIGH Leakage Current	$V_{IN} = V_{CC}$, $V_{CC} = \text{Max}$ (Note 2)		10	μA
I_{IL}	Input LOW Leakage Current	$V_{IN} = 0$ V, $V_{CC} = \text{Max}$ (Note 2)		-100	μA
I_{OZH}	Off-State Output Leakage Current HIGH	$V_{OUT} = V_{CC}$, $V_{CC} = \text{Max}$, $V_{IN} = V_{IL}$ or V_{IH} (Note 2)		10	μA
I_{OZL}	Off-State Output Leakage Current LOW	$V_{OUT} = 0$ V, $V_{CC} = \text{Max}$, $V_{IN} = V_{IL}$ or V_{IH} (Note 2)		-100	μA
I_{SC}	Output Short-Circuit Current	$V_{OUT} = 0.5$ V, $V_{CC} = \text{Max}$ (Note 3)	-30	-130	mA
I_{CC} (Static)	Supply Current	Outputs Open, ($I_{OUT} = 0$ mA), $V_{CC} = \text{Max}$		125	mA
I_{CC} (Dynamic)	Supply Current	Outputs Open, ($I_{OUT} = 0$ mA), $V_{CC} = \text{Max}$, $f = 25$ MHz		140	mA

Notes:

1. These are absolute values with respect to the device ground, and all overshoots due to system and tester noise are included.
2. I/O pin leakage is the worst case of I_{IL} and I_{OZL} (or I_{IH} and I_{OZH}).
3. Not more than one output should be tested at a time, and the duration of the short-circuit test should not exceed one second. $V_{OUT} = 0.5$ V has been chosen to avoid test problems caused by tester ground degradation.

CAPACITANCE ¹

Parameter Symbol	Parameter Description	Test Conditions		Typ	Unit
C _{IN}	Input Capacitance	V _{IN} = 2.0 V	V _{CC} = 5.0 V T _A = 25°C f = 1 MHz	5	pF
C _{OUT}	Output Capacitance	V _{OUT} = 2.0 V		8	

Note:

1. These parameters are not 100% tested, but are evaluated at initial characterization and at any time the design is modified where capacitance may be affected.

SWITCHING CHARACTERISTICS OVER COMMERCIAL OPERATING RANGES ¹

Parameter Symbol	Parameter Description		-5		Unit
			Min	Max	
t _{PD}	Input or Feedback to Combinatorial Output			5	ns
t _{S1}	Setup Time from Input or Feedback		3		ns
t _{S2}	Setup Time from SP to Clock		4		ns
t _H	Hold Time		0		ns
t _{CO}	Clock to Output			4	ns
t _{SKEWR}	Skew Between Registered Outputs (Note 2)			0.5	ns
t _{AR}	Asynchronous Reset to Registered Output			7.5	ns
t _{ARW}	Asynchronous Reset Width		4.5		ns
t _{ARR}	Asynchronous Reset Recovery Time		4.5		ns
t _{SPR}	Synchronous Preset Recovery Time		4.5		ns
t _{WL}	Clock Width	LOW	2.5		ns
t _{WH}		HIGH	2.5		ns
f _{MAX}	Maximum Frequency (Note 3)	External Feedback	1/(t _S + t _{CO})	142.8	MHz
		Internal Feedback (t _{CNT})	1/(t _S + t _{CF}) (Note 4)	150	MHz
		No Feedback	1/(t _{WH} + t _{WL})	200	MHz
t _{EA}	Input to Output Enable Using Product Term Control			6	ns
t _{ER}	Input to Output Disable Using Product Term Control			5.5	ns

Notes:

1. See "Switching Test Circuit" for test conditions.
2. Skew is measured with all outputs switching in the same direction.
3. These parameters are not 100% tested, but are calculated at initial characterization and at any time the design is modified where frequency may be affected.
4. t_{CF} is a calculated value and is not guaranteed. t_{CF} can be found using the following equation:
t_{CF} = 1/f_{MAX} (internal feedback) - t_S.

ABSOLUTE MAXIMUM RATINGS

Storage Temperature	-65°C to +150°C
Ambient Temperature with Power Applied	-55°C to +125°C
Supply Voltage with Respect to Ground	-0.5 V to +7.0 V
DC Input Voltage	-0.5 V to $V_{CC} + 1.0$ V
DC Output or I/O Pin Voltage	-0.5 V to $V_{CC} + 1.0$ V
Static Discharge Voltage	2001 V
Latchup Current ($T_A = 0^\circ\text{C}$ to $+75^\circ\text{C}$)	100 mA

Stresses above those listed under Absolute Maximum Ratings may cause permanent device failure. Functionality at or above these limits is not implied. Exposure to Absolute Maximum Ratings for extended periods may affect device reliability. Programming conditions may vary.

OPERATING RANGES

Commercial (C) Devices

Ambient Temperature (T_A)	Operating in Free Air	0°C to $+75^\circ\text{C}$
Supply Voltage (V_{CC}) with Respect to Ground		+4.75 V to +5.25 V

Operating ranges define those limits between which the functionality of the device is guaranteed.

DC CHARACTERISTICS OVER COMMERCIAL OPERATING RANGES

Symbol	Parameter Description	Test Conditions	Min	Max	Unit
V_{OH}	Output HIGH Voltage	$I_{OH} = -3.2$ mA, $V_{IN} = V_{IH}$ or V_{IL} , $V_{CC} = \text{Min}$	2.4		V
V_{OL}	Output LOW Voltage	$I_{OL} = 16$ mA, $V_{IN} = V_{IH}$ or V_{IL} , $V_{CC} = \text{Min}$		0.4	V
V_{IH}	Input HIGH Voltage	Guaranteed Input Logical HIGH Voltage for all Inputs (Note 1)	2.0		V
V_{IL}	Input LOW Voltage	Guaranteed Input Logical LOW Voltage for all Inputs (Note 1)		0.8	V
I_{IH}	Input HIGH Leakage Current	$V_{IN} = V_{CC}$, $V_{CC} = \text{Max}$ (Note 2)		10	μA
I_{IL}	Input LOW Leakage Current	$V_{IN} = 0$ V, $V_{CC} = \text{Max}$ (Note 2)		-100	μA
I_{OZH}	Off-State Output Leakage Current HIGH	$V_{OUT} = V_{CC}$, $V_{CC} = \text{Max}$, $V_{IN} = V_{IL}$ or V_{IH} (Note 2)		10	μA
I_{OZL}	Off-State Output Leakage Current LOW	$V_{OUT} = 0$ V, $V_{CC} = \text{Max}$, $V_{IN} = V_{IL}$ or V_{IH} (Note 2)		-100	μA
I_{SC}	Output Short-Circuit Current	$V_{OUT} = 0.5$ V, $V_{CC} = \text{Max}$ $T_A = 25^\circ\text{C}$ (Note 3)	-30	-130	mA
I_{CC} (Static)	Supply Current	Outputs Open, ($I_{OUT} = 0$ mA), $V_{CC} = \text{Max}$		115	mA
I_{CC} (Dynamic)	Supply Current	Outputs Open, ($I_{OUT} = 0$ mA), $V_{CC} = \text{Max}$, $f = 25$ MHz		140	mA

Notes:

- These are absolute values with respect to the device ground, and all overshoots due to system and tester noise are included.
- I/O pin leakage is the worst case of I_{IL} and I_{OZL} (or I_{IH} and I_{OZH}).
- Not more than one output should be tested at a time. Duration of the short-circuit test should not exceed one second. $V_{OUT} = 0.5$ V has been chosen to avoid test problems caused by tester ground degradation.

CAPACITANCE ¹

Parameter Symbol	Parameter Description	Test Conditions		Typ	Unit
C _{IN}	Input Capacitance	V _{IN} = 2.0 V	V _{CC} = 5.0 V T _A = 25°C f = 1 MHz	5	pF
C _{OUT}	Output Capacitance	V _{OUT} = 2.0 V		8	

Note:

1. These parameters are not 100% tested, but are evaluated at initial characterization and at any time the design is modified where capacitance may be affected.

SWITCHING CHARACTERISTICS OVER COMMERCIAL OPERATING RANGES ¹

Parameter Symbol	Parameter Description	-7				Unit
		PDIP		PLCC		
		Min	Max	Min	Max	
t _{PD}	Input or Feedback to Combinatorial Output	3	7.5	3	7.5	ns
t _{S1}	Setup Time from Input or Feedback	5		4.5		ns
t _{S2}	Setup Time from SP to Clock	6		6		ns
t _H	Hold Time	0		0		ns
t _{CO}	Clock to Output	2	5	2	4.5	ns
t _{SKEWR}	Skew Between Registered Outputs (Note 2)		1		1	ns
t _{AR}	Asynchronous Reset to Registered Output		10		10	ns
t _{ARW}	Asynchronous Reset Width	7		7		ns
t _{ARR}	Asynchronous Reset Recovery Time	7		7		ns
t _{SPR}	Synchronous Preset Recovery Time	7		7		ns
t _{WL}	Clock Width	LOW	3.5	3.0		ns
t _{WH}		HIGH	3.5	3.0		ns
f _{MAX}	Maximum Frequency (Note 3)	External Feedback	1/(t _S + t _{CO})	100	111	MHz
		Internal Feedback (f _{CNT})	1/(t _S + t _{CF}) (Note 4)	125	133	MHz
		No Feedback	1/(t _{WH} + t _{WL})	142.8	166	MHz
t _{EA}	Input to Output Enable Using Product Term Control		7.5		7.5	ns
t _{ER}	Input to Output Disable Using Product Term Control		7.5		7.5	ns

Notes:

1. See "Switching Test Circuit" for test conditions.
2. Skew is measured with all outputs switching in the same direction.
3. These parameters are not 100% tested, but are calculated at initial characterization and at any time the design is modified where frequency may be affected.
4. t_{CF} is a calculated value and is not guaranteed. t_{CF} can be found using the following equation:
t_{CF} = 1/f_{MAX} (internal feedback) - t_S.

ABSOLUTE MAXIMUM RATINGS

Storage Temperature -65°C to +150°C
 Ambient Temperature with
 Power Applied -55°C to +125°C
 Supply Voltage with Respect
 to Ground -0.5 V to +7.0 V
 DC Input Voltage -0.5 V to $V_{CC} + 1.0$ V
 DC Output or I/O Pin Voltage . . . -0.5 V to $V_{CC} + 1.0$ V
 Static Discharge Voltage 2001 V
 Latchup Current ($T_A = 0^\circ\text{C}$ to $+75^\circ\text{C}$) 100 mA

Stresses above those listed under Absolute Maximum Ratings may cause permanent device failure. Functionality at or above these limits is not implied. Exposure to absolute maximum ratings for extended periods may affect device reliability. Programming conditions may vary.

OPERATING RANGES

Commercial (C) Devices

Ambient Temperature (T_A)
 Operating in Free Air 0°C to $+75^\circ\text{C}$
 Supply Voltage (V_{CC}) with
 Respect to Ground +4.75 V to +5.25 V

Operating ranges define those limits between which the functionality of the device is guaranteed.

DC CHARACTERISTICS OVER COMMERCIAL OPERATING RANGES

Parameter Symbol	Parameter Description	Test Conditions	Min	Max	Unit
V_{OH}	Output HIGH Voltage	$I_{OH} = -3.2$ mA, $V_{IN} = V_{IH}$ or V_{IL} , $V_{CC} = \text{Min}$	2.4		V
V_{OL}	Output LOW Voltage	$I_{OL} = 16$ mA, $V_{IN} = V_{IH}$ or V_{IL} , $V_{CC} = \text{Min}$		0.4	V
V_{IH}	Input HIGH Voltage	Guaranteed Input Logical HIGH Voltage for all Inputs (Note 1)	2.0		V
V_{IL}	Input LOW Voltage	Guaranteed Input Logical LOW Voltage for all Inputs (Note 1)		0.8	V
I_{IH}	Input HIGH Leakage Current	$V_{IN} = V_{CC}$, $V_{CC} = \text{Max}$ (Note 2)		10	μA
I_{IL}	Input LOW Leakage Current	$V_{IN} = 0$ V, $V_{CC} = \text{Max}$ (Note 2)		-100	μA
I_{OZH}	Off-State Output Leakage Current HIGH	$V_{OUT} = V_{CC}$, $V_{CC} = \text{Max}$, $V_{IN} = V_{IL}$ or V_{IH} (Note 2)		10	μA
I_{OZL}	Off-State Output Leakage Current LOW	$V_{OUT} = 0$ V, $V_{CC} = \text{Max}$ $V_{IN} = V_{IL}$ or V_{IH} (Note 2)		-100	μA
I_{SC}	Output Short-Circuit Current	$V_{OUT} = 0.5$ V, $V_{CC} = \text{Max}$ $T_A = 25^\circ\text{C}$ (Note 3)	-30	-130	mA
I_{CC} (Dynamic)	Supply Current	Outputs Open, ($I_{OUT} = 0$ mA), $V_{CC} = \text{Max}$, $f = 25$ MHz		120	mA

Notes:

1. These are absolute values with respect to the device ground, and all overshoots due to system and tester noise are included.
2. I/O pin leakage is the worst case of I_{IL} and I_{OZL} (or I_{IH} and I_{OZH}).
3. Not more than one output should be tested at a time. Duration of the short-circuit test should not exceed one second. $V_{OUT} = 0.5$ V has been chosen to avoid test problems caused by tester ground degradation.

CAPACITANCE ¹

Parameter Symbol	Parameter Description	Test Conditions		Typ	Unit
C _{IN}	Input Capacitance	V _{IN} = 2.0 V	V _{CC} = 5.0 V T _A = 25°C f = 1 MHz	5	pF
C _{OUT}	Output Capacitance	V _{OUT} = 2.0 V		8	

Note:

1. These parameters are not 100% tested, but are evaluated at initial characterization and at any time the design is modified where capacitance may be affected.

SWITCHING CHARACTERISTICS OVER COMMERCIAL OPERATING RANGES ¹

Parameter Symbol	Parameter Description		-10		Unit
			Min	Max	
t _{PD}	Input or Feedback to Combinatorial Output			10	ns
t _{S1}	Setup Time from Input or Feedback		6		ns
t _{S2}	Setup Time from SP to Clock		7		ns
t _H	Hold Time		0		ns
t _{CO}	Clock to Output			6	ns
t _{AR}	Asynchronous Reset to Registered Output			13	ns
t _{ARW}	Asynchronous Reset Width		8		ns
t _{ARR}	Asynchronous Reset Recovery Time		8		ns
t _{SPR}	Synchronous Preset Recovery Time		8		ns
t _{WL}	Clock Width	LOW	4		ns
t _{WH}		HIGH	4		ns
f _{MAX}	Maximum Frequency (Note 2)	External Feedback	1/(t _S + t _{CO})	83.3	MHz
		Internal Feedback (f _{CNT})	1/(t _S + t _{CF}) (Note 3)	110	MHz
		No Feedback	1/(t _{WH} + t _{WL})	125	MHz
t _{EA}	Input to Output Enable Using Product Term Control			10	ns
t _{ER}	Input to Output Disable Using Product Term Control			9	ns

Notes:

1. See "Switching Test Circuit" for test conditions.
2. These parameters are not 100% tested, but are calculated at initial characterization and at any time the design is modified where frequency may be affected.
3. t_{CF} is a calculated value and is not guaranteed. t_{CF} can be found using the following equation:
t_{CF} = 1/f_{MAX} (internal feedback) - t_S.

ABSOLUTE MAXIMUM RATINGS

Storage Temperature	-65°C to +150°C
Ambient Temperature with Power Applied	-55°C to +125°C
Supply Voltage with Respect to Ground	-0.5 V to +7.0 V
DC Input Voltage	-0.5 V to $V_{CC} + 1.0$ V
DC Output or I/O Pin Voltage	-0.5 V to $V_{CC} + 1.0$ V
Static Discharge Voltage	2001 V
Latchup Current ($T_A = 0^\circ\text{C}$ to $+75^\circ\text{C}$)	100 mA

Stresses above those listed under Absolute Maximum Ratings may cause permanent device failure. Functionality at or above these limits is not implied. Exposure to Absolute Maximum Ratings for extended periods may affect device reliability. Programming conditions may vary.

OPERATING RANGES

Commercial (C) Devices

Ambient Temperature (T_A) Operating in Free Air	0°C to $+75^\circ\text{C}$
Supply Voltage (V_{CC}) with Respect to Ground	+4.75 V to +5.25 V

Operating ranges define those limits between which the functionality of the device is guaranteed.

DC CHARACTERISTICS OVER COMMERCIAL OPERATING RANGES

Parameter Symbol	Parameter Description	Test Conditions	Min	Max	Unit
V_{OH}	Output HIGH Voltage	$I_{OH} = -3.2$ mA, $V_{IN} = V_{IH}$ or V_{IL} , $V_{CC} = \text{Min}$	2.4		V
V_{OL}	Output LOW Voltage	$I_{OL} = 16$ mA, $V_{IN} = V_{IH}$ or V_{IL} , $V_{CC} = \text{Min}$		0.4	V
V_{IH}	Input HIGH Voltage	Guaranteed Input Logical HIGH Voltage for all Inputs (Note 1)	2.0		V
V_{IL}	Input LOW Voltage	Guaranteed Input Logical LOW Voltage for all Inputs (Note 1)		0.8	V
I_{IH}	Input HIGH Leakage Current	$V_{IN} = V_{CC}$, $V_{CC} = \text{Max}$ (Note 2)		10	μA
I_{IL}	Input LOW Leakage Current	$V_{IN} = 0$ V, $V_{CC} = \text{Max}$ (Note 2)		-100	μA
I_{OZH}	Off-State Output Leakage Current HIGH	$V_{OUT} = V_{CC}$, $V_{CC} = \text{Max}$ $V_{IN} = V_{IL}$ or V_{IH} (Note 2)		10	μA
I_{OZL}	Off-State Output Leakage Current LOW	$V_{OUT} = 0$ V, $V_{CC} = \text{Max}$ $V_{IN} = V_{IL}$ or V_{IH} (Note 2)		-100	μA
I_{SC}	Output Short-Circuit Current	$V_{OUT} = 0.5$ V, $V_{CC} = 5$ V $T_A = 25^\circ\text{C}$ (Note 3)	-30	-130	mA
I_{CC} (Static)	Supply Current	$V_{IN} = 0$ V, Outputs Open ($I_{OUT} = 0$ mA), $V_{CC} = \text{Max}$ (Note 4)		55	mA

Notes:

- These are absolute values with respect to the device ground, and all overshoots due to system and tester noise are included.
- I/O pin leakage is the worst case of I_{IL} and I_{OZL} (or I_{IH} and I_{OZH}).
- Not more than one output should be tested at a time, and the duration of the short-circuit test should not exceed one second. $V_{OUT} = 0.5$ V has been chosen to avoid test problems caused by tester ground degradation.
- This parameter is guaranteed worst case under test condition. Refer to the I_{CC} vs. frequency graph for typical I_{CC} characteristics.

CAPACITANCE ¹

Parameter Symbol	Parameter Description	Test Conditions		Typ	Unit
C _{IN}	Input Capacitance	V _{IN} = 2.0 V	V _{CC} = 5.0 V T _A = 25°C f = 1 MHz	5	pF
C _{OUT}	Output Capacitance	V _{OUT} = 2.0 V		8	

Note:

1. These parameters are not 100% tested, but are evaluated at initial characterization and at any time the design is modified where capacitance may be affected.

SWITCHING CHARACTERISTICS OVER COMMERCIAL OPERATING RANGES ¹

Parameter Symbol	Parameter Description		-10		Unit
			Min	Max	
t _{PD}	Input or Feedback to Combinatorial Output			10	ns
t _S	Setup Time from Input, Feedback or SP to Clock		6		ns
t _H	Hold Time		0		ns
t _{CO}	Clock to Output			6	ns
t _{AR}	Asynchronous Reset to Registered Output			13	ns
t _{ARW}	Asynchronous Reset Width		8		ns
t _{ARR}	Asynchronous Reset Recovery Time		8		ns
t _{SPR}	Synchronous Preset Recovery Time		8		ns
t _{WL}	Clock Width	LOW	4		ns
t _{WH}		HIGH	4		ns
f _{MAX}	Maximum Frequency (Note 2)	External Feedback	1/(t _S + t _{CO})	83	MHz
		Internal Feedback (f _{CNT})	1/(t _S + t _{CO}) (Note 3)	110	MHz
		No Feedback	1/(t _{WH} + t _{WL})	125	MHz
t _{EA}	Input to Output Enable Using Product Term Control			10	ns
t _{ER}	Input to Output Disable Using Product Term Control			9	ns

Notes:

1. See "Switching Test Circuit" for test conditions.
2. These parameters are not 100% tested, but are calculated at initial characterization and at any time the design is modified where frequency may be affected.
3. t_{CF} is a calculated value and is not guaranteed. t_{CF} can be found using the following equation:
t_{CF} = 1/f_{MAX} (internal feedback) - t_S.

ABSOLUTE MAXIMUM RATINGS

Storage Temperature	-65°C to +150°C
Ambient Temperature with Power Applied	-55°C to +125°C
Supply Voltage with Respect to Ground	-0.5 V to +7.0 V
DC Input Voltage	-0.5 V to $V_{CC} + 0.5$ V
DC Output or I/O Pin Voltage	-0.5 V to $V_{CC} + 0.5$ V
Static Discharge Voltage	2001 V
Latchup Current ($T_A = 0^\circ\text{C}$ to $+75^\circ\text{C}$)	100 mA

Stresses above those listed under Absolute Maximum Ratings may cause permanent device failure. Functionality at or above these limits is not implied. Exposure to Absolute Maximum Ratings for extended periods may affect device reliability. Programming conditions may vary.

OPERATING RANGES

Commercial (C) Devices

Ambient Temperature (T_A)	Operating in Free Air	0°C to $+75^\circ\text{C}$
Supply Voltage (V_{CC}) with Respect to Ground (H/Q-15)		+4.75 V to +5.25 V
Supply Voltage (V_{CC}) with Respect to Ground (H/Q-25)		+4.5 V to +5.5 V

Operating ranges define those limits between which the functionality of the device is guaranteed.

DC CHARACTERISTICS OVER COMMERCIAL OPERATING RANGES

Parameter Symbol	Parameter Description	Test Conditions	Min	Max	Unit
V_{OH}	Output HIGH Voltage	$I_{OH} = -3.2$ mA, $V_{IN} = V_{IH}$ or V_{IL} , $V_{CC} = \text{Min}$	2.4		V
V_{OL}	Output LOW Voltage	$I_{OL} = 16$ mA, $V_{IN} = V_{IH}$ or V_{IL} , $V_{CC} = \text{Min}$		0.4	V
V_{IH}	Input HIGH Voltage	Guaranteed Input Logical HIGH Voltage for all Inputs (Note 1)	2.0		V
V_{IL}	Input LOW Voltage	Guaranteed Input Logical LOW Voltage for all Inputs (Note 1)		0.8	V
I_{IH}	Input HIGH Leakage Current	$V_{IN} = V_{CC}$, $V_{CC} = \text{Max}$ (Note 2)		10	μA
I_{IL}	Input LOW Leakage Current	$V_{IN} = 0$ V, $V_{CC} = \text{Max}$ (Note 2)		-100	μA
I_{OZH}	Off-State Output Leakage Current HIGH	$V_{OUT} = V_{CC}$, $V_{CC} = \text{Max}$, $V_{IN} = V_{IL}$ or V_{IH} (Note 2)		10	μA
I_{OZL}	Off-State Output Leakage Current LOW	$V_{OUT} = 0$ V, $V_{CC} = \text{Max}$, $V_{IN} = V_{IL}$ or V_{IH} (Note 2)		-100	μA
I_{SC}	Output Short-Circuit Current	$V_{OUT} = 0.5$ V, $V_{CC} = 5$ V $T_A = 25^\circ\text{C}$ (Note 3)	-30	-130	mA
I_{CC}	Supply Current	$V_{IN} = 0$ V, Outputs Open ($I_{OUT} = 0$ mA), $V_{CC} = \text{Max}$	H	90	mA
			Q	55	

Notes:

1. These are absolute values with respect to the device ground, and all overshoots due to system and tester noise are included.
2. I/O pin leakage is the worst case of I_{IL} and I_{OZL} (or I_{IH} and I_{OZH}).
3. Not more than one output should be tested at a time, and the duration of the short-circuit test should not exceed one second. $V_{OUT} = 0.5$ V has been chosen to avoid test problems caused by tester ground degradation.

CAPACITANCE ¹

Parameter Symbol	Parameter Description	Test Conditions		Typ	Unit
C _{IN}	Input Capacitance	V _{IN} = 2.0 V	V _{CC} = 5.0 V	5	pF
C _{OUT}	Output Capacitance	V _{OUT} = 2.0 V	T _A = 25°C f = 1 MHz	8	

Note:

1. These parameters are not 100% tested, but are evaluated at initial characterization and at any time the design is modified where capacitance may be affected.

SWITCHING CHARACTERISTICS OVER COMMERCIAL OPERATING RANGES ¹

Parameter Symbol	Parameter Description		-15		-25		Unit
			Min	Max	Min	Max	
t _{PD}	Input or Feedback to Combinatorial Output			15		25	ns
t _S	Setup Time from Input, Feedback or SP to Clock		10		15		ns
t _H	Hold Time		0		0		ns
t _{CO}	Clock to Output			10		15	ns
t _{AR}	Asynchronous Reset to Registered Output			20		25	ns
t _{ARW}	Asynchronous Reset Width		15		25		ns
t _{ARR}	Asynchronous Reset Recovery Time		10		25		ns
t _{SPR}	Synchronous Preset Recovery Time		10		25		ns
t _{WL}	Clock Width	LOW	8		13		ns
t _{WH}		HIGH	8		13		ns
f _{MAX}	Maximum Frequency (Note 2)	External Feedback	1/(t _S + t _{CO})	50		33.3	MHz
		Internal Feedback (f _{CNT})	1/(t _S + t _{CF}) (Note 3)	58.8		35.7	MHz
t _{EA}	Input to Output Enable Using Product Term Control			15		25	ns
t _{ER}	Input to Output Disable Using Product Term Control			15		25	ns

Notes:

1. See "Switching Test Circuit" for test conditions.
2. These parameters are not 100% tested, but are evaluated at initial characterization and at any time the design is modified where frequency may be affected.
3. t_{CF} is a calculated value and is not guaranteed. t_{CF} can be found using the following equation:
t_{CF} = 1/f_{MAX} (internal feedback) - t_S

ABSOLUTE MAXIMUM RATINGS

Storage Temperature	-65°C to +150°C
Ambient Temperature with Power Applied	-55°C to +125°C
Supply Voltage with Respect to Ground	-0.5 V to +7.0 V
DC Input Voltage	-0.5 V to $V_{CC} + 0.5$ V
DC Output or I/O Pin Voltage	-0.5 V to $V_{CC} + 0.5$ V
Static Discharge Voltage	2001 V
Latchup Current ($T_A = -40^\circ\text{C}$ to $+85^\circ\text{C}$)	100 mA

Stresses above those listed under Absolute Maximum Ratings may cause permanent device failure. Functionality at or above these limits is not implied. Exposure to Absolute Maximum Ratings for extended periods may affect device reliability. Programming conditions may vary.

OPERATING RANGES

Industrial (I) Devices

Ambient Temperature (T_A)	Operating in Free Air	-40°C to +85°C
Supply Voltage (V_{CC}) with Respect to Ground		+4.5 V to +5.5 V

Operating ranges define those limits between which the functionality of the device is guaranteed.

DC CHARACTERISTICS OVER INDUSTRIAL OPERATING RANGES

Parameter Symbol	Parameter Description	Test Conditions	Min	Max	Unit
V_{OH}	Output HIGH Voltage	$I_{OH} = -3.2$ mA, $V_{IN} = V_{IH}$ or V_{IL} , $V_{CC} = \text{Min}$	2.4		V
V_{OL}	Output LOW Voltage	$I_{OL} = 16$ mA, $V_{IN} = V_{IH}$ or V_{IL} , $V_{CC} = \text{Min}$		0.4	V
V_{IH}	Input HIGH Voltage	Guaranteed Input Logical HIGH Voltage for all Inputs (Note 1)	2.0		V
V_{IL}	Input LOW Voltage	Guaranteed Input Logical LOW Voltage for all Inputs (Note 1)		0.8	V
I_{IH}	Input HIGH Leakage Current	$V_{IN} = V_{CC}$, $V_{CC} = \text{Max}$ (Note 2)		10	μA
I_{IL}	Input LOW Leakage Current	$V_{IN} = 0$ V, $V_{CC} = \text{Max}$ (Note 2)		-100	μA
I_{OZH}	Off-State Output Leakage Current HIGH	$V_{OUT} = V_{CC}$, $V_{CC} = \text{Max}$, $V_{IN} = V_{IL}$ or V_{IH} (Note 2)		10	μA
I_{OZL}	Off-State Output Leakage Current LOW	$V_{OUT} = 0$ V, $V_{CC} = \text{Max}$, $V_{IN} = V_{IL}$ or V_{IH} (Note 2)		-100	μA
I_{SC}	Output Short-Circuit Current	$V_{OUT} = 0.5$ V, $V_{CC} = 5$ V $T_A = 25^\circ\text{C}$ (Note 3)	-30	-130	mA
I_{CC} (Static)	Supply Current	H-20/25		100	mA
		H-10/15		110	
I_{CC} (Dynamic)	Supply Current	$V_{IN} = 0$ V, Outputs Open ($I_{OUT} = 0$ mA), $V_{CC} = \text{Max}$, $f = 15$ MHz		130	mA

Notes:

1. These are absolute values with respect to the device ground, and all overshoots due to system and tester noise are included.
2. I/O pin leakage is the worst case of I_{IL} and I_{OZL} (or I_{IH} and I_{OZH}).
3. Not more than one output should be tested at a time, and the duration of the short-circuit test should not exceed one second. $V_{OUT} = 0.5$ V has been chosen to avoid test problems caused by tester ground degradation.

CAPACITANCE ¹

Parameter Symbol	Parameter Description	Test Conditions		Typ	Unit
C _{IN}	Input Capacitance	V _{IN} = 2.0 V	V _{CC} = 5.0 V T _A = 25°C f = 1 MHz	5	pF
C _{OUT}	Output Capacitance	V _{OUT} = 2.0 V		8	

Note:

1. These parameters are not 100% tested, but are evaluated at initial characterization and at any time the design is modified where capacitance may be affected.

SWITCHING CHARACTERISTICS OVER INDUSTRIAL OPERATING RANGES ¹

Parameter Symbol	Parameter Description		-10		-15		-20		-25		Unit
			Min	Max	Min	Max	Min	Max	Min	Max	
t _{PD}	Input or Feedback to Combinatorial Output			10		15		20		25	ns
t _S	Setup Time from Input, Feedback or SP to Clock		7		10		12		15		ns
t _H	Hold Time		0		0		0		0		ns
t _{CO}	Clock to Output			6		10		12		15	ns
t _{AR}	Asynchronous Reset to Registered Output			13		20		25		25	ns
t _{ARW}	Asynchronous Reset Width		8		15		20		25		ns
t _{ARR}	Asynchronous Reset Recovery Time		8		10		20		25		ns
t _{SPR}	Synchronous Preset Recovery Time		8		10		14		25		ns
t _{WL}	Clock Width	LOW	4		8		10		13		ns
t _{WH}		HIGH	4		8		10		13		ns
f _{MAX}	Maximum Frequency (Note 2)	External Feedback	1/(t _S + t _{CO})	83.3		50		41.6		33.3	MHz
		Internal Feedback (f _{CNT})	1/(t _S + t _{CF}) (Note 3)	110		58.8		45.4		35.7	MHz
		No Feedback	1/(t _{WH} + t _{WL})	125		83.3		50		38.5	MHz
t _{EA}	Input to Output Enable Using Product Term Control			10		15		20		25	ns
t _{ER}	Input to Output Disable Using Product Term Control			9		15		20		25	ns

Notes:

1. See "Switching Test Circuit" for test conditions.
2. These parameters are not 100% tested, but are calculated at initial characterization and at any time the design is modified where frequency may be affected.
3. t_{CF} is a calculated value and is not guaranteed. t_{CF} can be found using the following equation:
t_{CF} = 1/f_{MAX} (internal feedback) - t_S.

ABSOLUTE MAXIMUM RATINGS

Storage Temperature	-65°C to +150°C
Ambient Temperature with Power Applied	-55°C to +125°C
Supply Voltage with Respect to Ground	-0.5 V to +7.0 V
DC Input Voltage	-0.5 V to $V_{CC} + 0.5$ V
DC Output or I/O Pin Voltage	-0.5 V to $V_{CC} + 0.5$ V
Static Discharge Voltage	2001 V
Latchup Current ($T_A = -40^\circ\text{C}$ to $+85^\circ\text{C}$)	100 mA

Stresses above those listed under Absolute Maximum Ratings may cause permanent device failure. Functionality at or above these limits is not implied. Exposure to Absolute Maximum Ratings for extended periods may affect device reliability. Programming conditions may differ.

OPERATING RANGES

Industrial (I) Devices

Ambient Temperature (T_A)	-40°C to +85°C
Supply Voltage (V_{CC}) with Respect to Ground	+4.5 V to +5.5 V

Operating ranges define those limits between which the functionality of the device is guaranteed.

DC CHARACTERISTICS OVER INDUSTRIAL OPERATING RANGES

Parameter Symbol	Parameter Description	Test Conditions	Min	Max	Unit
V_{OH}	Output HIGH Voltage	$V_{IN} = V_{IH}$ or V_{IL} $V_{CC} = \text{Min}$	$I_{OH} = -6$ mA	3.84	V
			$I_{OH} = -20$ μA	$V_{CC}-0.1$	V
V_{OL}	Output LOW Voltage	$V_{IN} = V_{IH}$ or V_{IL} $V_{CC} = \text{Min}$	$I_{OL} = 16$ mA	0.5	V
			$I_{OL} = 6$ mA	0.33	V
			$I_{OL} = 20$ μA	0.1	V
V_{IH}	Input HIGH Voltage	Guaranteed Input Logical HIGH Voltage for all Inputs (Notes 1, 2)	2.0	V	
V_{IL}	Input LOW Voltage	Guaranteed Input Logical LOW Voltage for all Inputs (Notes 1, 2)	0.9	V	
I_{IH}	Input HIGH Leakage Current	$V_{IN} = V_{CC}$, $V_{CC} = \text{Max}$ (Note 3)		10	μA
I_{IL}	Input LOW Leakage Current	$V_{IN} = 0$ V, $V_{CC} = \text{Max}$ (Note 3)		-10	μA
I_{OZH}	Off-State Output Leakage Current HIGH	$V_{OUT} = V_{CC}$, $V_{CC} = \text{Max}$ $V_{IN} = V_{IH}$ or V_{IL} (Note 3)		10	μA
I_{OZL}	Off-State Output Leakage Current LOW	$V_{OUT} = 0$ V, $V_{CC} = \text{Max}$ $V_{IN} = V_{IH}$ or V_{IL} (Note 3)		-10	μA
I_{SC}	Output Short-Circuit Current	$V_{OUT} = 0.5$ V, $V_{CC} = \text{Max}$ (Note 4)	-5	-150	mA
I_{CC}	Supply Current	Outputs Open ($I_{OUT} = 0$ mA) $V_{CC} = \text{Max}$	f = 0 MHz	30	μA
			f = 15 MHz	100	mA

Notes:

1. These are absolute values with respect to device ground, and all overshoots due to system or tester noise are included.
2. Represents the worst case of HC and HCT standards, allowing compatibility with either.
3. I/O pin leakage is the worst case of I_{IL} and I_{OZL} (or I_{IH} and I_{OZH}).
4. Not more than one output should be shorted at a time, and the duration of the short-circuit should not exceed one second. $V_{OUT} = 0.5$ V has been chosen to avoid test problems caused by tester ground degradation

CAPACITANCE ¹

Parameter Symbol	Parameter Description	Test Conditions		Typ	Unit
C _{IN}	Input Capacitance	V _{IN} = 2.0 V	V _{CC} = 5.0 V T _A = 25°C f = 1 MHz	5	pF
C _{OUT}	Output Capacitance	V _{OUT} = 2.0 V		8	

Note:

1. These parameters are not 100% tested, but are evaluated at initial characterization and at any time the design is modified where capacitance may be affected.

SWITCHING CHARACTERISTICS OVER INDUSTRIAL OPERATING RANGES ¹

Parameter Symbol	Parameter Description		-15		Unit
			Min	Max	
t _{PD}	Input or Feedback to Combinatorial Output			15	ns
t _S	Setup Time from Input, Feedback or SP to Clock		10		ns
t _H	Hold Time		0		ns
t _{CO}	Clock to Output			10	ns
t _{AR}	Asynchronous Reset to Registered Output			20	ns
t _{ARW}	Asynchronous Reset Width		15		ns
t _{ARR}	Asynchronous Reset Recovery Time		10		ns
t _{SPR}	Synchronous Preset Recovery Time		10		ns
t _{WL}	Clock Width	LOW	8		ns
t _{WH}		HIGH	8		ns
f _{MAX}	Maximum Frequency (Note 2)	External Feedback	1/(t _S + t _{CO})	50	MHz
		Internal Feedback (f _{CNT})	1/(t _S + t _{CF}) (Note 3)	58.8	MHz
		No Feedback	1/(t _{WH} + t _{WL})	62.5	MHz
t _{EA}	Input to Output Enable Using Product Term Control			15	ns
t _{ER}	Input to Output Disable Using Product Term Control			15	ns

Notes:

1. See "Switching Test Circuit" for test conditions.
2. These parameters are not 100% tested, but are evaluated at initial characterization and at any time the design is modified where frequency may be affected.
3. t_{CF} is a calculated value and is not guaranteed. t_{CF} can be found using the following equation:
t_{CF} = 1/f_{MAX} (internal feedback) - t_S.

ABSOLUTE MAXIMUM RATINGS

Storage Temperature -65°C to +150°C
 Ambient Temperature with
 Power Applied -55°C to +125°C
 Supply Voltage with Respect
 to Ground -0.5 V to +7.0 V
 DC Input Voltage -0.5 V to $V_{CC} + 0.5$ V
 DC Output or I/O Pin
 Voltage -0.5 V to $V_{CC} + 0.5$ V
 Static Discharge Voltage 2001 V
 Latchup Current ($T_A = -40^\circ\text{C}$ to $+85^\circ\text{C}$) 100 mA

Stresses above those listed under Absolute Maximum Ratings may cause permanent device failure. Functionality at or above these limits is not implied. Exposure to Absolute Maximum Ratings for extended periods may affect device reliability. Programming conditions may differ.

OPERATING RANGES

Commercial (C) Devices

Ambient Temperature (T_A) 0°C to +75°C
 Supply Voltage (V_{CC}) with
 Respect to Ground +4.75 V to +5.25 V

Industrial (I) Devices

Ambient Temperature (T_A) -40°C to +85°C
 Supply Voltage (V_{CC}) with
 Respect to Ground +4.5 V to +5.5 V

Operating ranges define those limits between which the functionality of the device is guaranteed.

DC CHARACTERISTICS OVER COMMERCIAL AND INDUSTRIAL OPERATING RANGES

Parameter Symbol	Parameter Description	Test Conditions		Min	Max	Unit
V_{OH}	Output HIGH Voltage	$V_{IN} = V_{IH}$ or V_{IL} $V_{CC} = \text{Min}$	$I_{OH} = -6$ mA	3.84		V
			$I_{OH} = -20$ μA	$V_{CC}-0.1$		V
V_{OL}	Output LOW Voltage	$V_{IN} = V_{IH}$ or V_{IL} $V_{CC} = \text{Min}$	$I_{OL} = 16$ mA		0.5	V
			$I_{OL} = 6$ mA		0.33	V
			$I_{OL} = 20$ μA		0.1	V
V_{IH}	Input HIGH Voltage	Guaranteed Input Logical HIGH Voltage for all Inputs (Notes 1, 2)		2.0		V
V_{IL}	Input LOW Voltage	Guaranteed Input Logical LOW Voltage for all Inputs (Notes 1, 2)			0.9	V
I_{IH}	Input HIGH Leakage Current	$V_{IN} = V_{CC}$, $V_{CC} = \text{Max}$ (Note 3)			10	μA
I_{IL}	Input LOW Leakage Current	$V_{IN} = 0$ V, $V_{CC} = \text{Max}$ (Note 3)			-10	μA
I_{OZH}	Off-State Output Leakage Current HIGH	$V_{OUT} = V_{CC}$, $V_{CC} = \text{Max}$, $V_{IN} = V_{IH}$ or V_{IL} (Note 3)			10	μA
I_{OZL}	Off-State Output Leakage Current LOW	$V_{OUT} = 0$ V, $V_{CC} = \text{Max}$, $V_{IN} = V_{IH}$ or V_{IL} (Note 3)			-10	μA
I_{SC}	Output Short-Circuit Current	$V_{OUT} = 0.5$ V, $V_{CC} = \text{Max}$ (Note 4)		-5	-150	mA
I_{CC}	Supply Current	Outputs Open ($I_{OUT} = 0$ mA) $V_{CC} = \text{Max}$	f = 0 MHz		30	μA
			f = 15 MHz		120	mA

Notes:

1. These are absolute values with respect to device ground, and all overshoots due to system or tester noise are included.
2. Represents the worst case of HC and HCT standards, allowing compatibility with either.
3. I/O pin leakage is the worst case of I_{IL} and I_{OZL} (or I_{IH} and I_{OZH}).
4. Not more than one output should be shorted at a time, and the duration of the short-circuit should not exceed one second. $V_{OUT} = 0.5$ V has been chosen to avoid test problems caused by tester ground degradation.

CAPACITANCE ¹

Parameter Symbol	Parameter Description	Test Conditions		Typ	Unit
C _{IN}	Input Capacitance	V _{IN} = 2.0 V	V _{CC} = 5.0 V T _A = 25°C f = 1 MHz	5	pF
C _{OUT}	Output Capacitance	V _{OUT} = 2.0 V		8	

Note:

1. These parameters are not 100% tested, but are evaluated at initial characterization and at any time the design is modified where capacitance may be affected.

SWITCHING CHARACTERISTICS OVER COMMERCIAL AND INDUSTRIAL OPERATING RANGES ¹

Parameters Symbol	Parameter Description		-25		Unit
			Min	Max	
t _{PD}	Input or Feedback to Combinatorial Output (Note 2)			25	ns
t _S	Setup Time from Input, Feedback or SP to Clock		15		ns
t _H	Hold Time		0		ns
t _{CO}	Clock to Output			15	ns
t _{AR}	Asynchronous Reset to Registered Output			25	ns
t _{ARW}	Asynchronous Reset Width		25		ns
t _{ARR}	Asynchronous Reset Recovery Time		25		ns
t _{SPR}	Synchronous Preset Recovery Time		25		ns
t _{WL}	Clock Width	LOW	10		ns
t _{WH}		HIGH	10		ns
f _{MAX}	Maximum Frequency (Notes 3)	External Feedback	1/(t _S + t _{CO})	33.3	MHz
		Internal Feedback (t _{CNT})	1/(t _S + t _{CF}) (Note 4)	35.7	MHz
		No Feedback	1/(t _{WH} + t _{WL})	50	MHz
t _{EA}	Input to Output Enable Using Product Term Control			25	ns
t _{ER}	Input to Output Disable Using Product Term Control			25	ns

Notes:

1. See "Switching Test Circuit" for test conditions.
2. This parameter is tested in Standby Mode. When the device is not in Standby Mode, the t_{PD} will typically be 5 ns faster.
3. These parameters are not 100% tested, but are evaluated at initial characterization and at any time the design is modified where frequency may be affected.
4. t_{CF} is a calculated value and is not guaranteed. t_{CF} can be found using the following equation:

$$t_{CF} = 1/f_{MAX} \text{ (internal feedback)} - t_S$$

SWITCHING WAVEFORMS

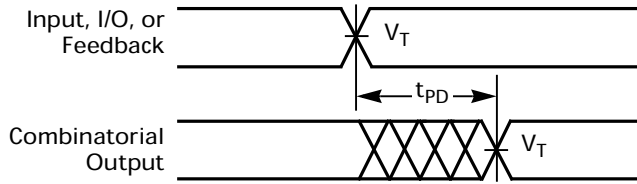

a. Combinatorial output

16564-007

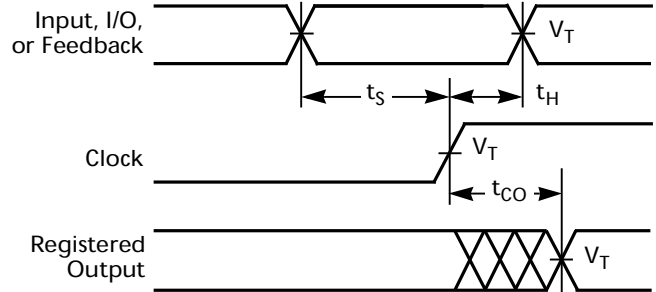

b. Registered output

16564-008

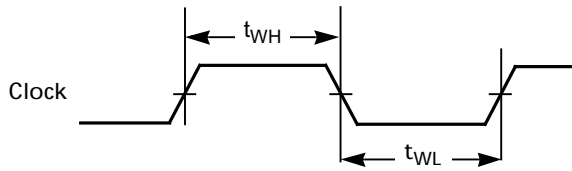

c. Clock width

16564-009

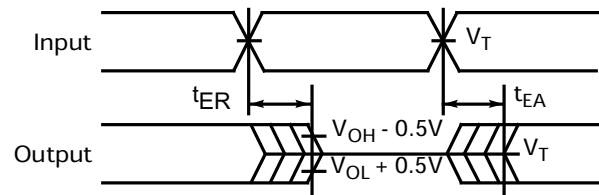

d. Input to output disable/enable

16564-010

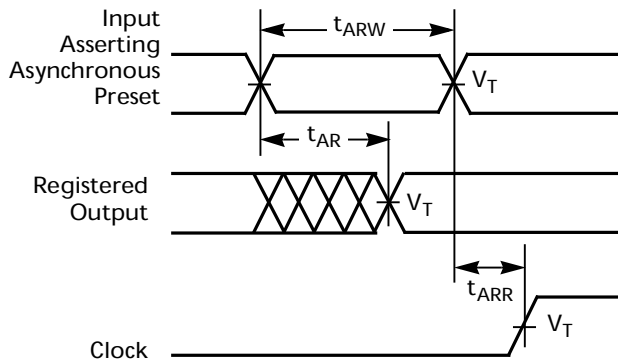

e. Asynchronous reset

16564-011

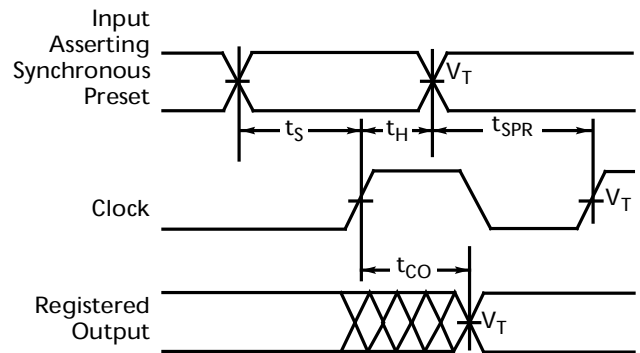

f. Synchronous preset

16564-012

Notes:

1. $V_T = 1.5\text{ V}$.
2. Input pulse amplitude 0 V to 3.0 V.
3. Input rise and fall times 2 ns to 5 ns typical.

KEY TO SWITCHING WAVEFORMS

WAVEFORM	INPUTS	OUTPUTS
	Must be Steady	Will be Steady
	May Change from H to L	Will be Changing from H to L
	May Change from L to H	Will be Changing from L to H
	Don't Care, Any Change Permitted	Changing, State Unknown
	Does Not Apply	Center Line is High-Impedance "Off" State

16564E-013

SWITCHING TEST CIRCUIT

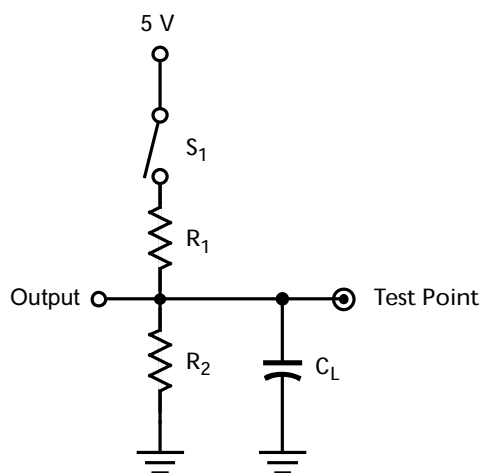

16564-014

Specification	S ₁	C _L	Commercial		Measured Output Value
			R ₁	R ₂	
t _{PD} , t _{CO}	Closed	50 pF	300 Ω	All except H-5/7: 390 Ω	1.5 V
t _{EA}	Z → H: Open				1.5 V
	Z → L: Closed				
t _{ER}	H → Z: Open	5 pF		H-5/7:	H → Z: V _{OH} - 0.5 V
	L → Z: Closed		300 Ω	L → Z: V _{OL} + 0.5 V	

TYPICAL I_{CC} CHARACTERISTICS

$V_{CC} = 5.0\text{ V}$, $T_A = 25^\circ\text{C}$

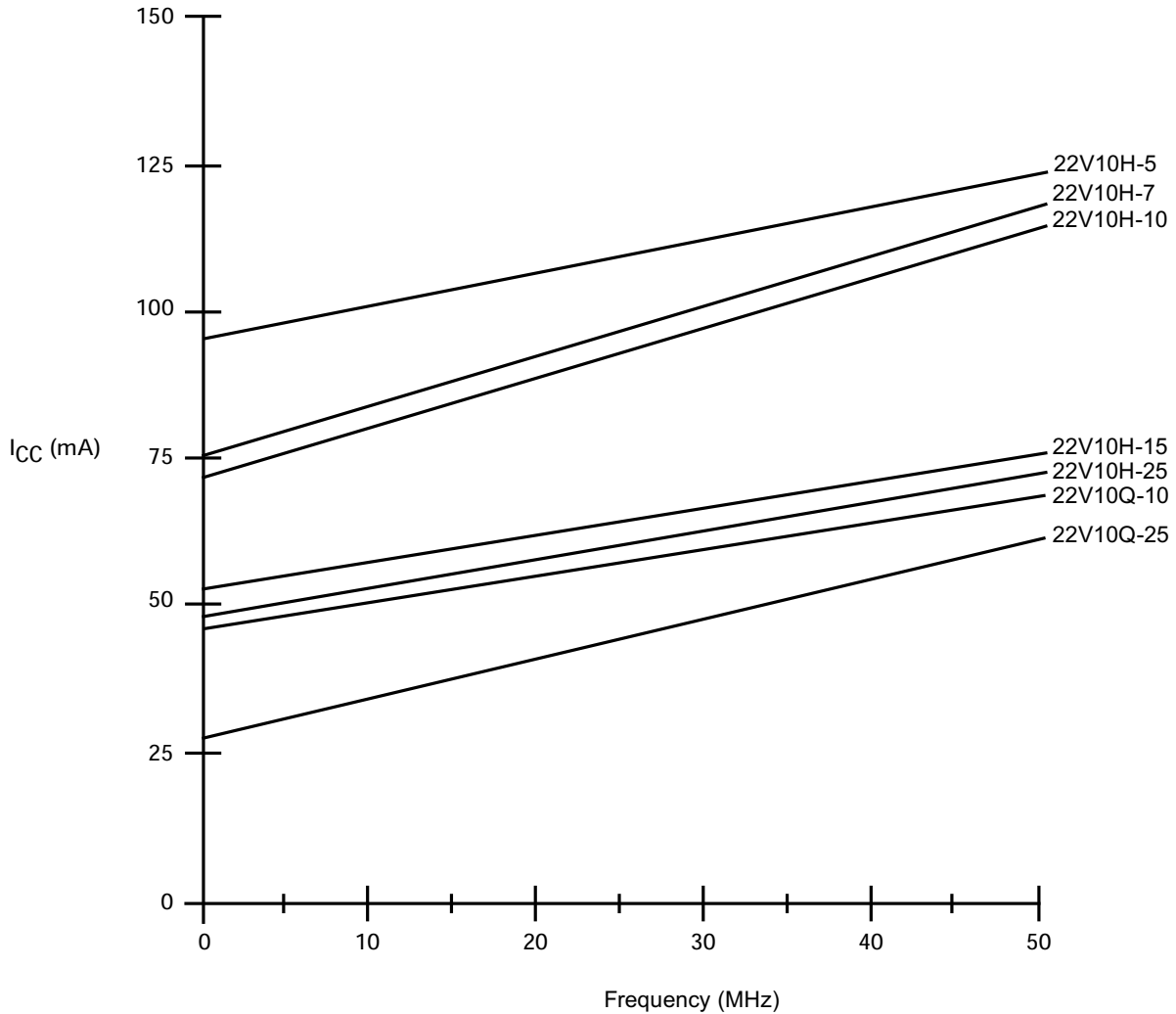

I_{CC} vs. Frequency

16564E-015

The selected "typical" pattern utilized 50% of the device resources. Half of the macrocells were programmed as registered, and the other half were programmed as combinatorial. Half of the available product terms were used for each macrocell. On any vector, half of the outputs were switching.

By utilizing 50% of the device, a midpoint is defined for I_{CC} . From this midpoint, a designer may scale the I_{CC} graphs up or down to estimate the I_{CC} requirements for a particular design.

TYPICAL I_{CC} CHARACTERISTICS FOR THE PALCE22V10Z-15

$V_{CC} = 5.0 \text{ V}$, $T_A = 25^\circ\text{C}$

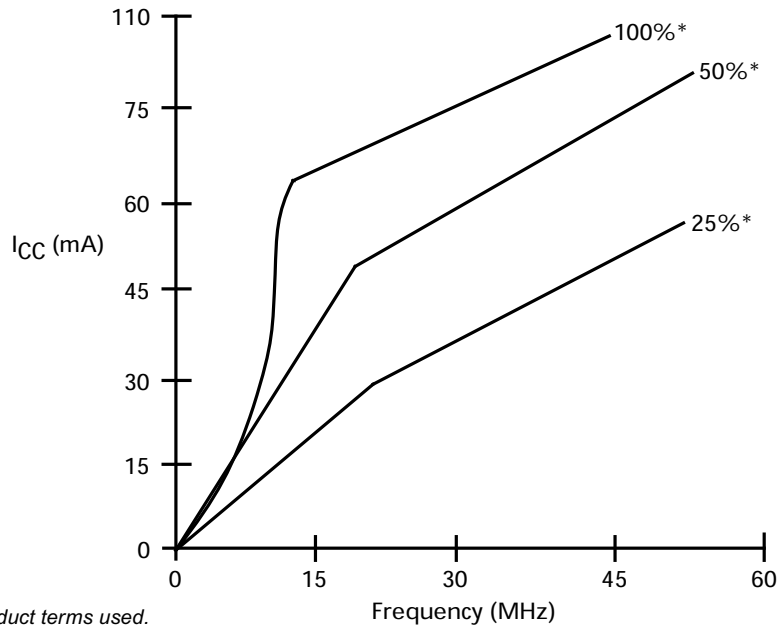

16564E-016

I_{CC} vs. Frequency Graph for the PALCE22V10Z-15

TYPICAL I_{CC} CHARACTERISTICS FOR THE PALCE22V10Z-25

$V_{CC} = 5.0 \text{ V}$, $T_A = 25^\circ\text{C}$

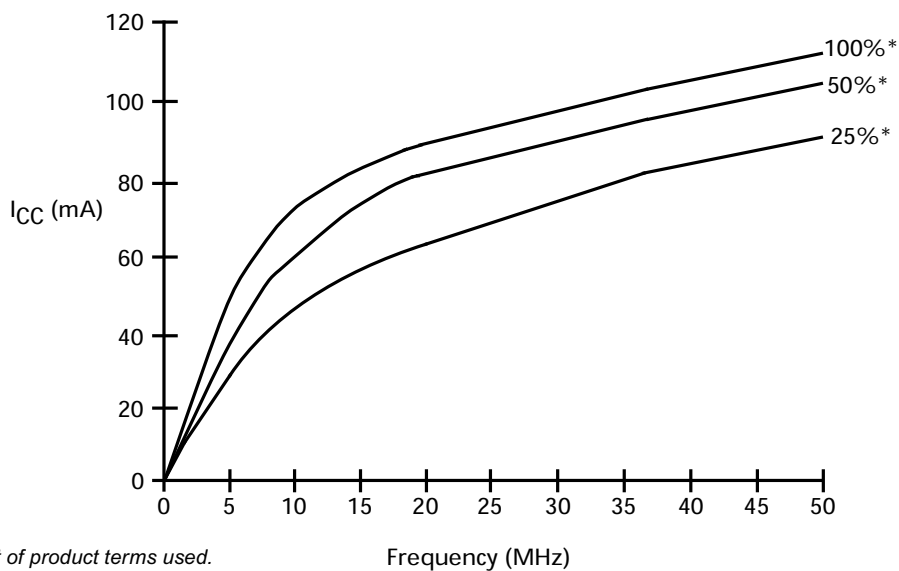

16564E-017

I_{CC} vs. Frequency Graph for the PALCE22V10Z-25

ENDURANCE CHARACTERISTICS

The PALCE22V10 is manufactured using Vantis' advanced electrically-erasable (EE) CMOS process. This technology uses an EE cell to replace the fuse link used in bipolar parts. As a result, the device can be erased and reprogrammed—a feature which allows 100% testing at the factory.

Symbol	Parameter	Test Conditions	Value	Unit
t_{DR}	Min Pattern Data Retention Time	Max Storage Temperature	10	Years
N	Max Reprogramming Cycles	Normal Programming Conditions	100	Cycles

INPUT/OUTPUT EQUIVALENT SCHEMATICS FOR SELECTED /4 DEVICES*

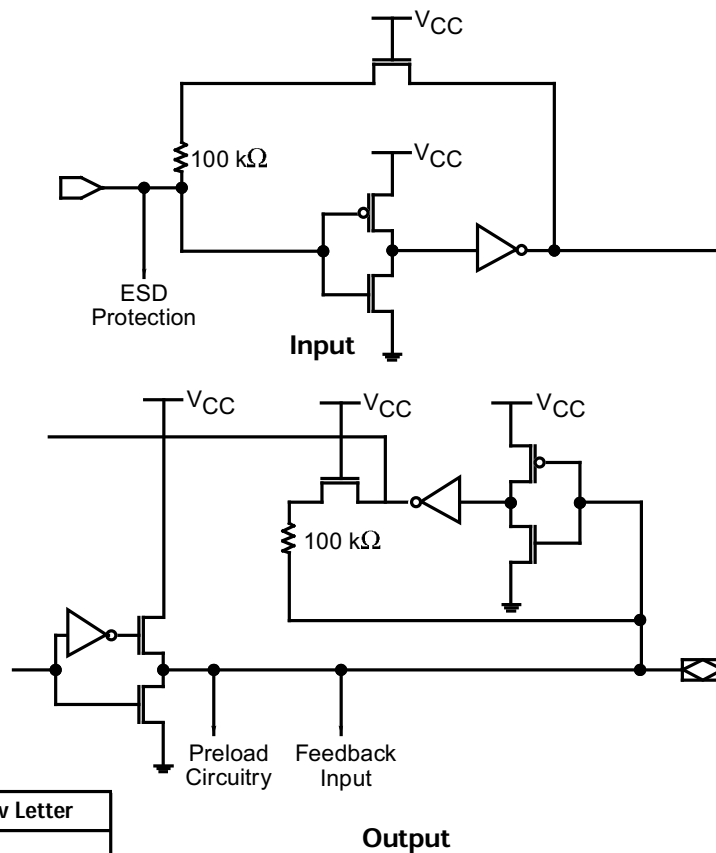

*

Device	Rev Letter
PALCE22V10H-15	H
PALCE22V10H-20H	
PALCE22V10H-25	
PALCE22V10Q-25I	I

16564E-018

ROBUSTNESS FEATURES

The PALCE22V10X-X/5 devices have some unique features that make them extremely robust, especially when operating in high-speed design environments. Pull-up resistors on inputs and I/O pins cause unconnected pins to default to a known state. Input clamping circuitry limits negative overshoot, eliminating the possibility of false clocking caused by subsequent ringing. A special noise filter makes the programming circuitry completely insensitive to any positive overshoot that has a pulse width of less than about 100 ns for the /5 version.

INPUT/OUTPUT EQUIVALENT SCHEMATICS FOR /5 VERSION DEVICES

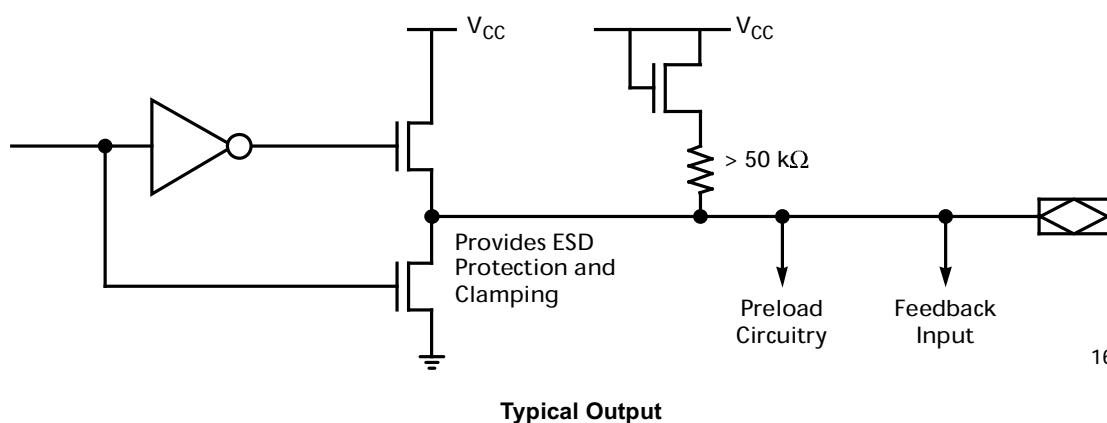
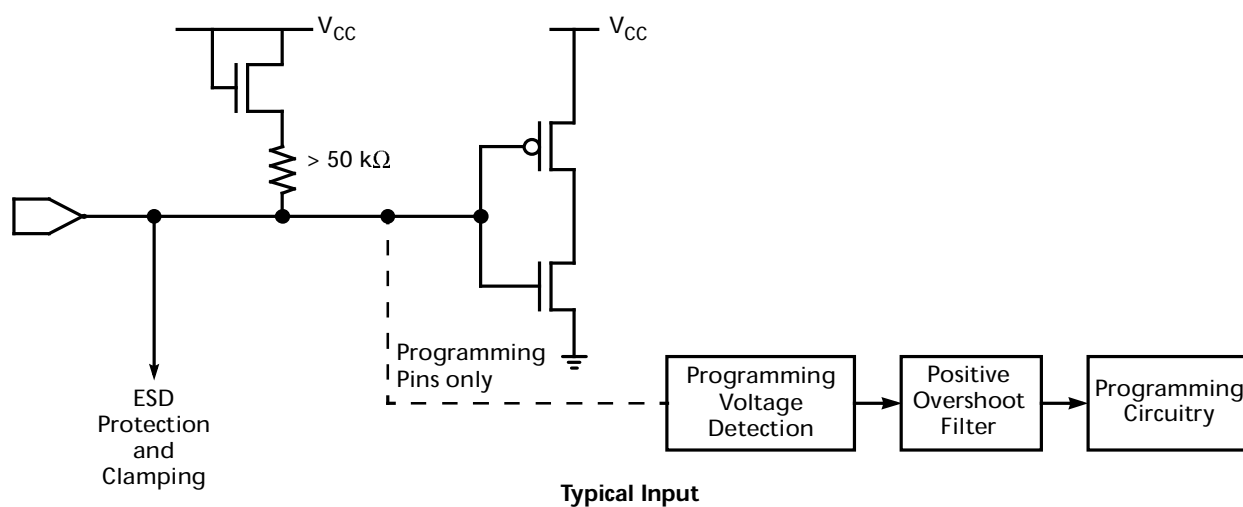

16564-16

INPUT/OUTPUT EQUIVALENT SCHEMATICS FOR PALCE22V10Z

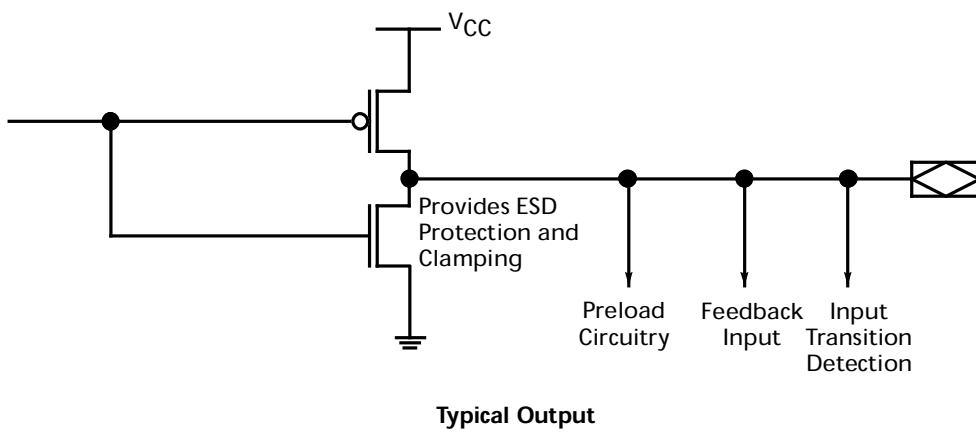
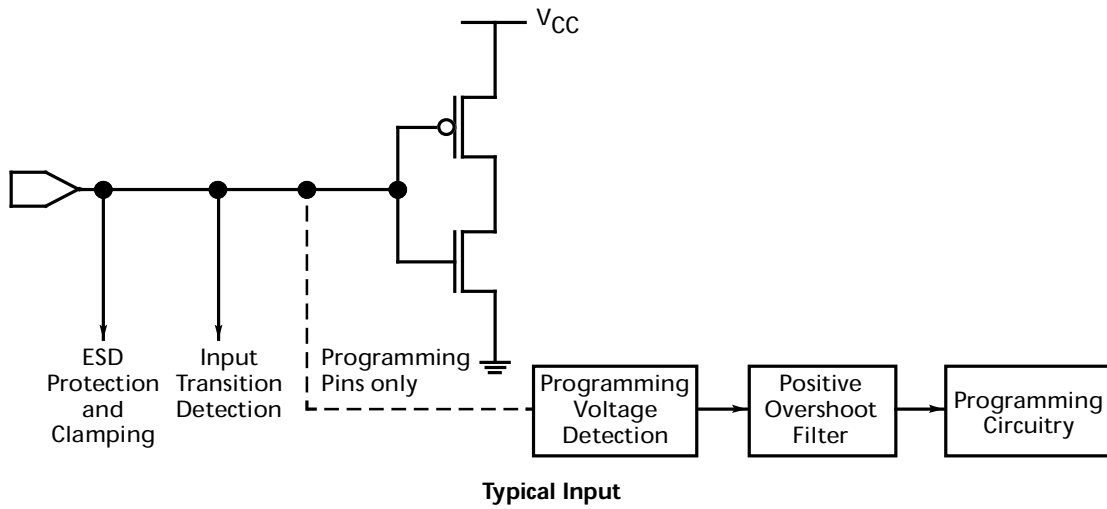

16564E-020

POWER-UP RESET

The power-up reset feature ensures that all flip-flops will be reset to LOW after the device has been powered up. The output state will depend on the programmed pattern. This feature is valuable in simplifying state machine initialization. A timing diagram and parameter table are shown below. Due to the synchronous operation of the power-up reset and the wide range of ways V_{CC} can rise to its steady state, two conditions are required to ensure a valid power-up reset. These conditions are:

- ◆ The V_{CC} rise must be monotonic.
- ◆ Following reset, the clock input must not be driven from LOW to HIGH until all applicable input and feedback setup times are met.

Parameter Symbol	Parameter Description	Max	Unit
t_{PR}	Power-up Reset Time	1000	ns
t_S	Input or Feedback Setup Time	See Switching Characteristics	
t_{WL}	Clock Width LOW		

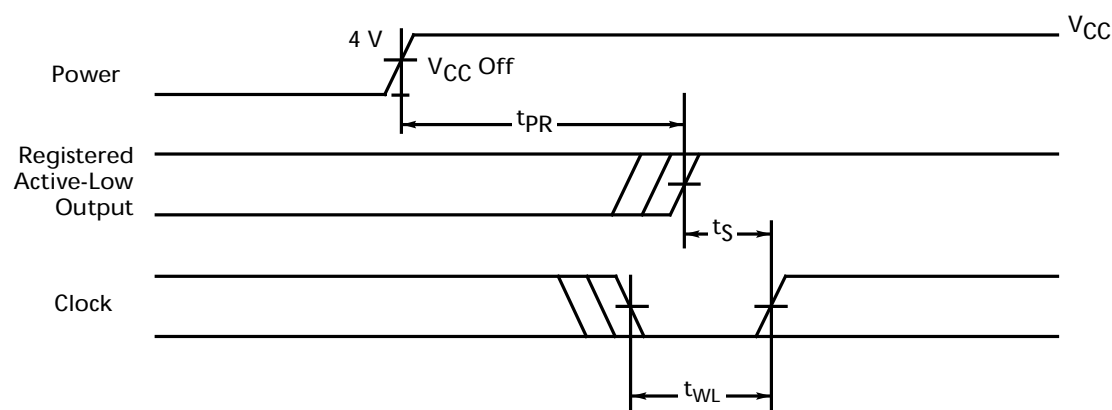

16564E-021

Figure 3. Power-Up Reset Waveform

TYPICAL THERMAL CHARACTERISTICS

PALCE22V10

Measured at 25°C ambient. These parameters are not tested.

Parameter Symbol	Parameter Description	Typ		Unit	
		SKINNY DIP	PLCC		
θ_{jc}	Thermal impedance, junction to case	20	18	°C/W	
θ_{ja}	Thermal impedance, junction to ambient	73	55	°C/W	
θ_{jma}	Thermal impedance, junction to ambient with air flow	200 lpm air	66	48	°C/W
		400 lpm air	61	43	°C/W
		600 lpm air	55	40	°C/W
		800 lpm air	52	37	°C/W

Plastic θ_{jc} Considerations

The data listed for plastic θ_{jc} are for reference only and are not recommended for use in calculating junction temperatures. The heat-flow paths in plastic-encapsulated devices are complex, making the θ_{jc} measurement relative to a specific location on the package surface. Tests indicate this measurement reference point is directly below the die-attach area on the bottom center of the package. Furthermore, θ_{jc} tests on packages are performed in a constant-temperature bath, keeping the package surface at a constant temperature. Therefore, the measurements can only be used in a similar environment.

CONNECTION DIAGRAMS

Top View

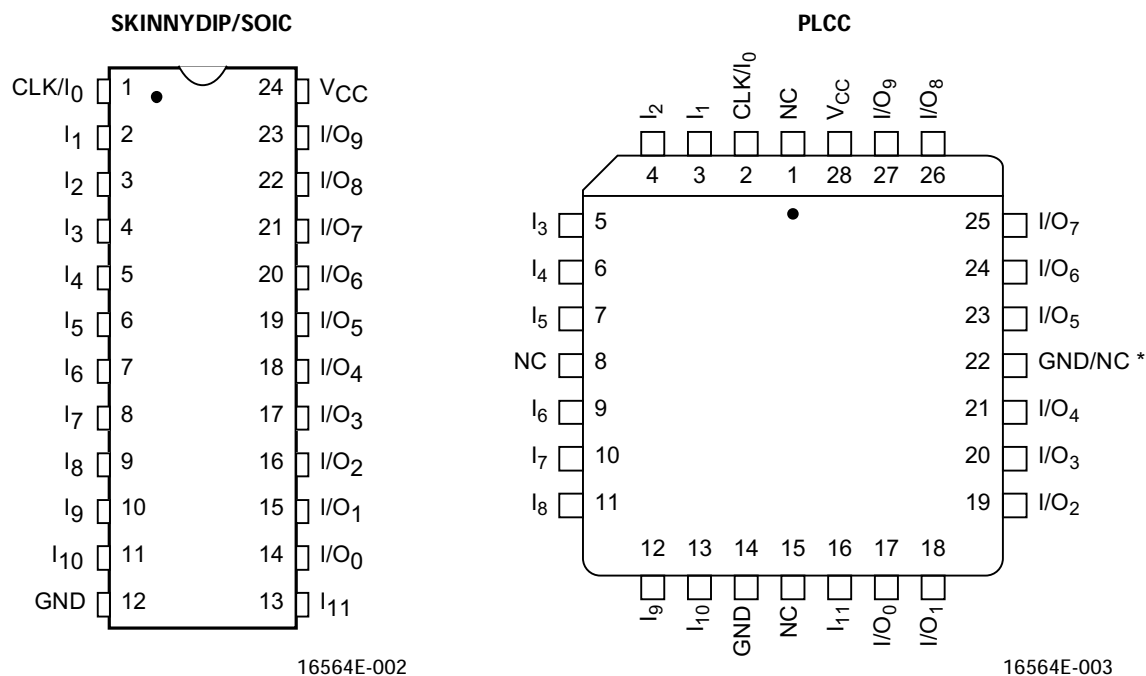

*For -5, this pin must be grounded for guaranteed data sheet performance. If not grounded, AC timing may degrade by about 10%.

Note:

Pin 1 is marked for orientation.

PIN DESIGNATIONS

- CLK = Clock
- GND = Ground
- I = Input
- I/O = Input/Output
- NC = No Connect
- V_{CC} = Supply Voltage

ORDERING INFORMATION

Commercial and Industrial Products

Lattice/Vantis programmable logic products for commercial and industrial applications are available with several ordering options. The order number (Valid Combination) is formed by a combination of:

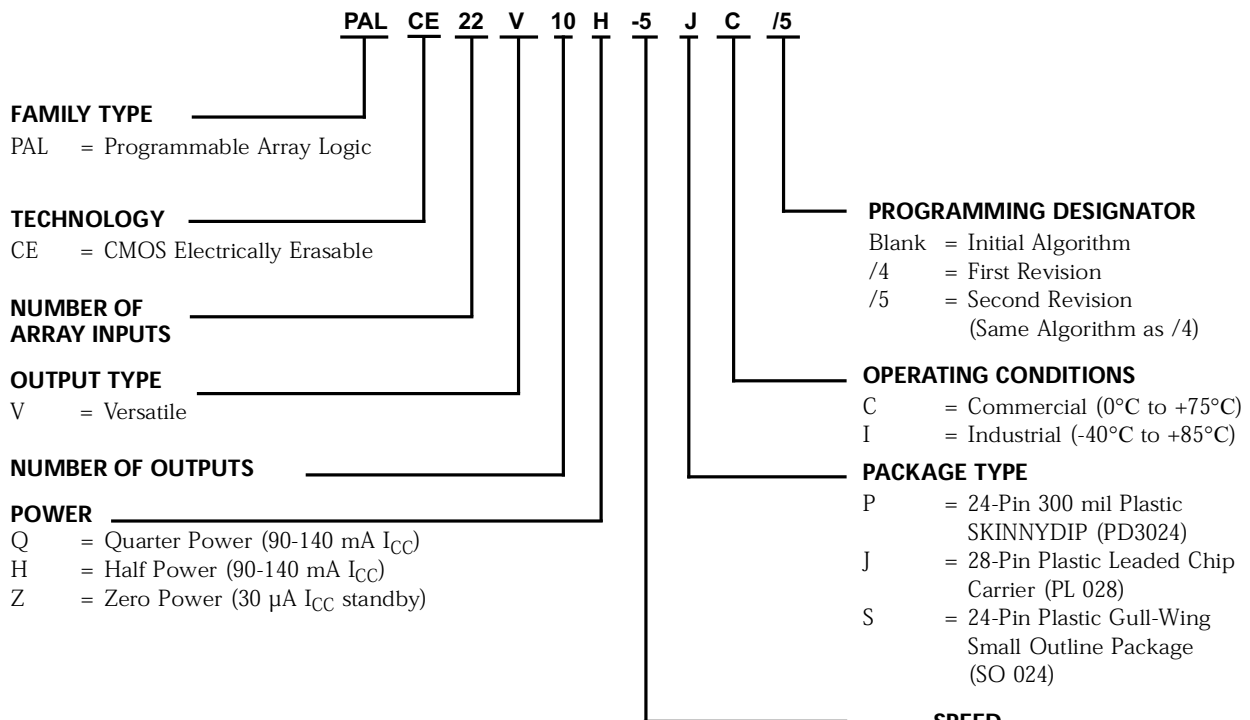

SPEED

-5	= 5 ns t_{pD}
-7	= 7.5 ns t_{pD}
-10	= 10 ns t_{pD}
-15	= 15 ns t_{pD}
-20	= 20 ns t_{pD}
-25	= 25 ns t_{pD}

Valid Combinations

Valid Combinations		
PALCE22V10H-5	JC	/5
PALCE22V10H-7	PC, JC	
PALCE22V10H-10	PC, JC, SC, PI, JI	
PALCE22V10Q-10	PC, JC	
PALCE22V10H-15	PC, JC, PI, JI, SC	/4
PALCE22V10Q-15	PC, JC	/5
PALCE22V10H-20	PI, JI	/4
PALCE22V10H-25	PC, JC, SC, PI, JI	/4
PALCE22V10Q-25	PC, JC	
PALCE22V10Z-15	PI, JI	
PALCE22V10Z-25	PC, JC, SC, PI, JI, SI	

Valid Combinations

Valid Combinations list configurations planned to be supported in volume for this device. Consult the local Lattice/Vantis sales office to confirm availability of specific valid combinations and to check on newly released combinations.