

### Features

- Low On-Resistance (33-Ohm typ.) Minimizes Distortion and Error Voltages
- Low Glitching Reduces Step Errors in Sample-and-Holds. Charge Injection, 2pC typ.
- Single-Supply Operation (+2.5V to +16V)
- Improved Second Sources for MAX323/MAX324/MAX325
- On-Resistance Matching Between Channels, <2-Ohm
- On-Resistance Flatness, <6-Ohm max.
- Low Off-Channel Leakage, <5nA @ +85°C
- TTL/CMOS Logic Compatible
- Fast Switching Speed,  $t_{ON} < 150ns$
- Guaranteed Break-Before-Make action (PS325 only) eliminates momentary crosstalk
- v Rail-to-Rail Analog Signal Dynamic Range
- Low Power Consumption, <5mW
- MSOP Package Minimizes Board Area

### Applications

- Audio Switching and Routing
- Portable Instruments
- Data Acquisition Systems
- Sample-and-Holds
- Telecommunication Systems
- Battery-Powered Systems

### Description

The PS323/PS324/PS325 are improved high-precision, medium-voltage analog switches designed to operate with single power supplies. The PS323 is a dual, single-pole single-throw (SPST), normally open (NO) switch. The PS324 has the same pinout as the PS323 but it has two normally closed (NC) switches. The PS325 has one normally open (NO) and one normally closed (NC) switch per package. Each switch conducts current equally well in either direction when on. In the off state, each switch blocks voltages up to the power-supply rail.

With a +5V power supply, PS323/PS324/PS325 guarantee <60-ohm ON-resistance. ON-resistance matching between channels is within 2W. ON-resistance flatness is less than 6W over the specified range. All three devices guarantee low leakage currents (<100 pA @ 25°C, <10nA @ +85°C) and fast switching speeds ( $t_{ON} < 150ns$ ). Break-before-make switching action protects against momentary crosstalk (PS325).

For single-supply operation below 5V, PI5A317/318/319 are also recommended.

### Functional Diagrams, Pin Configurations, and Truth Tables

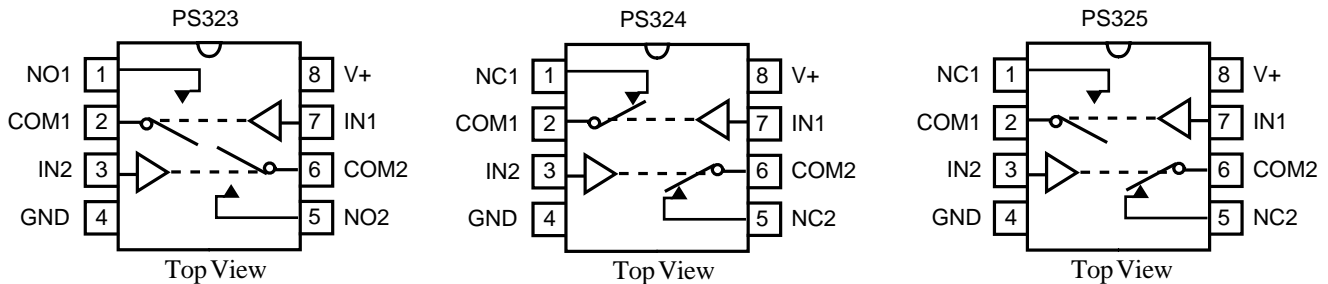

**Switches shown for logic “0” input**

PS323	
Logic	Switch
0	OFF
1	ON

PS324	
Logic	Switch
0	ON
1	OFF

PS325		
Logic	Switch 1	Switch 2
0	OFF	ON
1	ON	OFF

### Absolute Maximum Ratings

Voltages Referenced to GND .....	
V+ .....	-0.3V to +17V
V <sub>IN</sub> , V <sub>COM</sub> , V <sub>NC</sub> , V <sub>NO</sub> <sup>(1)</sup> .....	-2V to (V+)+2V
or 30mA, whichever occurs first	
Current (any terminal) .....	30mA
Peak Current, COM, NO, NC	
(pulsed at 1ms, 10% duty cycle) .....	100mA
ESD per Method 3015.7 .....	>2000V

### Thermal Information

Continuous Power Dissipation	
Plastic DIP (derate 6mW/°C above +70°C) .....	500mW
Narrow SO (derate 6mW/°C above +70°C) .....	450mW
MSOP (derate 4mW/°C above +70°C) .....	330mW
Storage Temperature .....	-65°C to +150°C
Lead Temperature (soldering, 10s) .....	+300°C

**Note 1:** Signals on NC, NO, COM, or IN exceeding V+ or GND are clamped by internal diodes. Limit forward diode current to 30mA maximum.

**Caution:** Stresses beyond those listed under “Absolute Maximum Ratings” may cause permanent damage to the device. This is a stress only rating and operation of the device at these or any other conditions beyond those indicated in the operational sections of this specification is not implied.

### Electrical Specifications - Single +5V Supply

(V+ = 5V +10%, GND = 0V, V<sub>INH</sub> = 2.4V, V<sub>INL</sub> = 0.8V)

Parameter	Symbol	Conditions	Temp. (°C)	Min <sup>(2)</sup>	Typ <sup>(1)</sup>	Max <sup>(2)</sup>	Units
<b>Analog Switch</b>							
Analog Signal Range <sup>(3)</sup>	V <sub>ANALOG</sub>		Full	0		V+	V
On Resistance	R <sub>ON</sub>	V+ = 4.5V, V <sub>NO</sub> or V <sub>NC</sub> = +3.5V I <sub>COM</sub> = 1mA	25		33	60	Ω
			Full			75	
On-Resistance Match Between Channels <sup>(4)</sup>	ΔR <sub>ON</sub>	V <sub>NO</sub> or V <sub>NC</sub> = +3V, I <sub>COM</sub> = 1mA, V+ = 5V	25		0.8	2	
			Full			4	
On-Resistance Flatness <sup>(5)</sup>	R <sub>FLAT(ON)</sub>	V+ = 5V, I <sub>COM</sub> = 1mA, V <sub>NO</sub> or V <sub>NC</sub> = 1V, 2V, 3V,	25		2	6	
			Full			8	
NO or NC Off Leakage Current <sup>(6)</sup>	I <sub>NO(OFF)</sub> or I <sub>NC(OFF)</sub>	V+ = 5.5V, V <sub>COM</sub> = 1V, V <sub>NO</sub> or V <sub>NC</sub> = 4.5V	25	-0.1	-0.01	0.1	
			Full	-5		5	
COM Off Leakage Current <sup>(6)</sup>	I <sub>COM(OFF)</sub>	V+ = 5.5V, V <sub>COM</sub> = 4.5V, V <sub>NO</sub> or V <sub>NC</sub> = 1V	25	-0.1	-0.01	0.1	nA
			Full	-5		5	
COM On Leakage Current <sup>(6)</sup>	I <sub>COM(ON)</sub>	V+ = 5.5V, V <sub>COM</sub> = 5V, V <sub>NO</sub> or V <sub>NC</sub> = 5V	25	-0.2	-0.04	0.2	
			Full	-10		10	

**Electrical Specifications - Single +5V Supply** (continued)

(V<sub>+</sub> = 5V ±10%, GND = 0V, V<sub>INH</sub> = 2.4V, V<sub>INL</sub> = 0.8V)

Parameter	Symbol	Conditions	Temp. (°C)	Min <sup>(1)</sup>	Typ <sup>(2)</sup>	Max <sup>(1)</sup>	Units
<b>Logic Input</b>							
Input Current with Input Voltage High	I <sub>INH</sub>	V <sub>IN</sub> = 2.4V, all others = 0.8V	Full	-0.5	0.005	0.5	μA
Input Current with Input Voltage Low	I <sub>INL</sub>	V <sub>IN</sub> = 0.8V, all others = 2.4V		-0.5	0.005	0.5	
Logic High Input Voltage	V <sub>INH</sub>			2.4			V
Logic Low Input Voltage	V <sub>INL</sub>					0.8	
<b>Dynamic</b>							
Turn-On Time	t <sub>ON</sub>	V <sub>NO</sub> OR V <sub>NC</sub> = 3V, Figure 2	25		85	150	ns
			Full			240	
Turn-Off Time	t <sub>OFF</sub>		25		25	100	
			Full			150	
Break-Before-Make Time Delay <sup>(3)</sup>	t <sub>D</sub>	PS325 only, R <sub>L</sub> = 300Ω, C <sub>L</sub> = 35pF, Figure 3	25	2	5		pC
Charge Injection <sup>(3)</sup>	Q	C <sub>L</sub> = 1nF, V <sub>GEN</sub> = 0V, R <sub>GEN</sub> = 0Ω, Figure 4			1	5	
Off Isolation <sup>(7)</sup>	OIRR	R <sub>L</sub> = 50Ω, C <sub>L</sub> = 5pF, f = 1MHz, Figure 5				-72	
Crosstalk	X <sub>TALK</sub>	R <sub>L</sub> = 50Ω, C <sub>L</sub> = 5pF, f = 1MHz, Figure 6				-85	
NC or NO Off Capacitance	C <sub>(OFF)</sub>	f = 1MHz, Figure 7				9	pF
COM Off Capacitance	C <sub>COM(OFF)</sub>					9	
COM On Capacitance	C <sub>COM(ON)</sub>			f = 1MHz, Figure 8			
<b>Supply</b>							
Power-Supply Range	V <sub>+</sub>		Full	2.7		16	V
Positive Supply Current	I <sub>+</sub>	V <sub>+</sub> = 5.5V, V <sub>IN</sub> = 0V or V <sub>+</sub> , all channels on or off			-1		1

**Notes:**

- The algebraic convention, where the most negative value is a minimum and the most positive is a maximum, is used in this data sheet.
- Typical values are for DESIGN AID ONLY, not guaranteed or subject to production testing.
- Guaranteed by design
- ΔR<sub>ON</sub> = R<sub>ON</sub> max - R<sub>ON</sub> min
- Flatness is defined as the difference between the maximum and minimum value of ON-resistance measured.
- Leakage parameters are 100% tested at maximum rated hot temperature and guaranteed by correlation at +25°C.
- Off Isolation = 20log<sub>10</sub> [ V<sub>COM</sub> / (V<sub>NC</sub> OR V<sub>NO</sub>) ]. See Figure 5.

**Electrical Specifications - Single +3.3V Supply**

( $V_+ = 3.3V \pm 10\%$ ,  $GND = 0V$ ,  $V_{INH} = 2.4V$ ,  $V_{INL} = 0.8V$ )

Parameter	Symbol	Conditions	Temp (°C)	Min <sup>(1)</sup>	Typ <sup>(2)</sup>	Max <sup>(1)</sup>	Units
<b>Analog Switch</b>							
Analog Signal Range <sup>(3)</sup>	$V_{ANALOG}$			0		$V_+$	V
On-Resistance	$R_{ON}$	$V_+ = 3V$ , $I_{COM} = 1mA$ , $V_{NO}$ or $V_{NC} = 1.5V$	25		83	175	$\Omega$
			Full			275	
<b>Dynamic</b>							
Turn-On Time <sup>(3)</sup>	$t_{ON}$	$V_{NO}$ or $V_{NC} = 1.5V$ , Figure 2	25		160	400	ns
			Full			500	
Turn-Off Time <sup>(3)</sup>	$t_{OFF}$		25		40	125	
			Full			175	
Break-Before-Make Time Delay <sup>(3)</sup>	$t_D$	PS325 only	25	2	5		
Charge Injection <sup>(3)</sup>	Q	$C_L = 1nF$ , $V_{GEN} = 0V$ , $R_{GEN} = 0\Omega$ , Figure 4	25		1	5	pC
<b>Supply</b>							
Positive Supply Current	$I_+$	$V_+ = 3.6V$ , $V_{IN} = 0V$ or $V_+$ , all channels on or off	Full	-1	0.01	1	$\mu A$

Test Circuits/Timing Diagrams

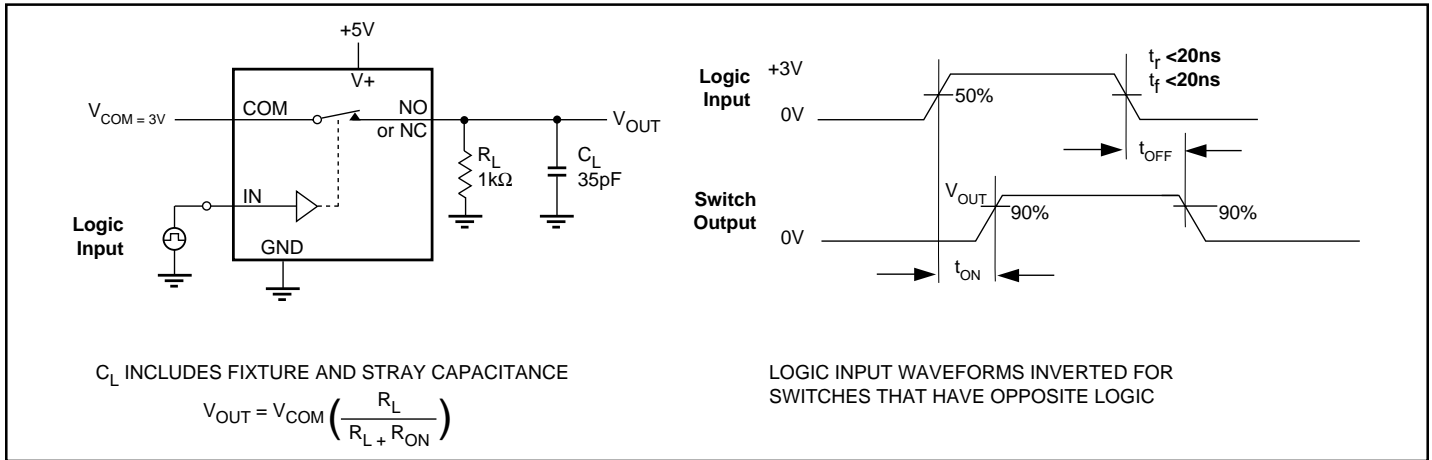

Figure 2. Switching Time

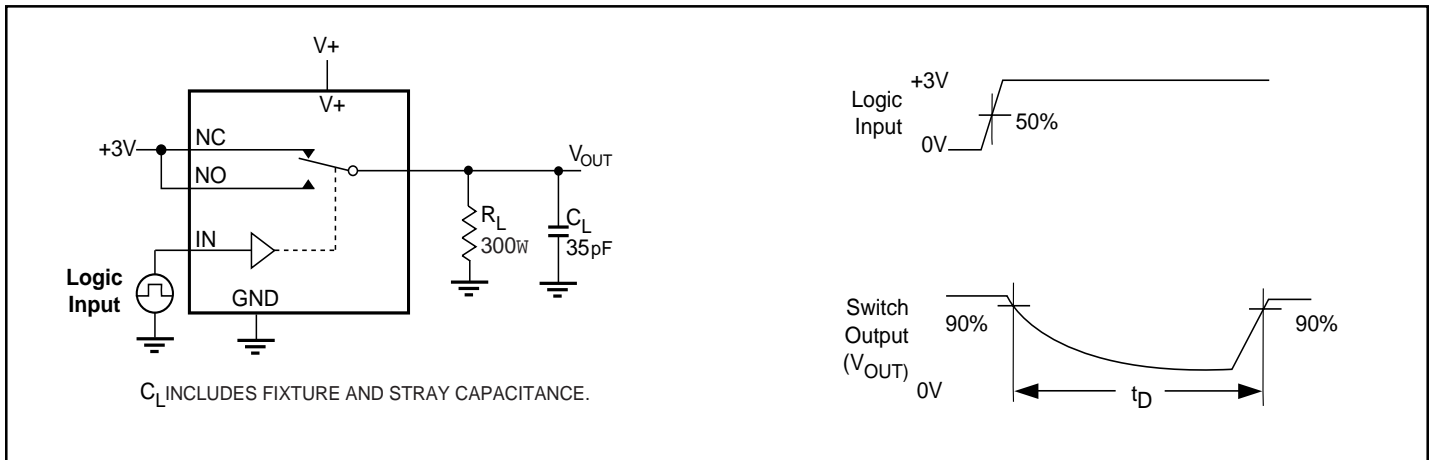

Figure 3. Break-Before-Make Interval (PS325 only)

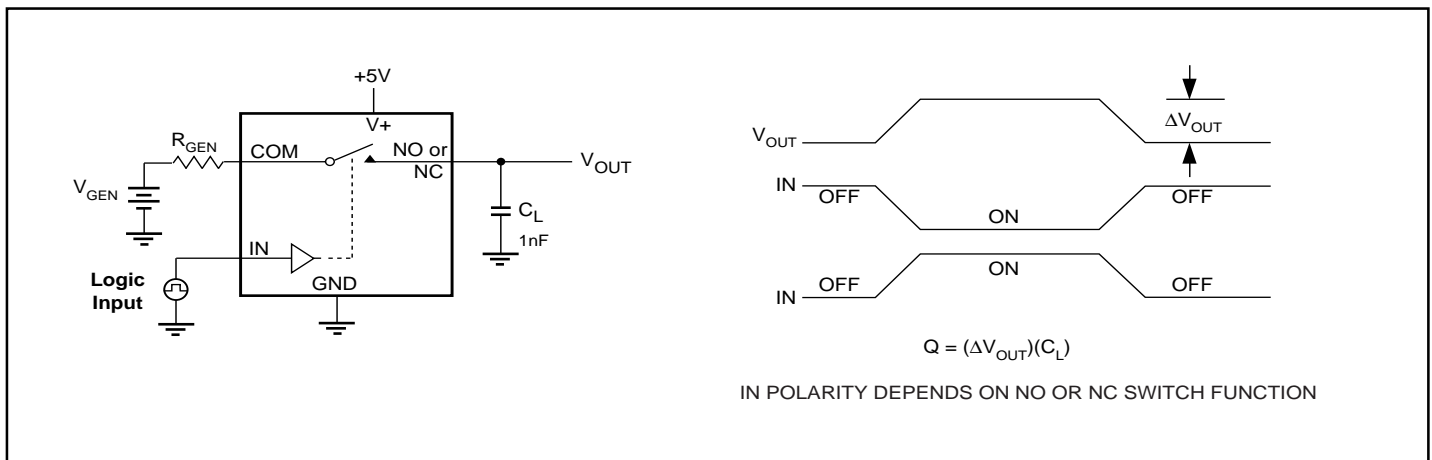

Figure 4. Charge Injection

Test Circuits/Timing Diagrams (continued)

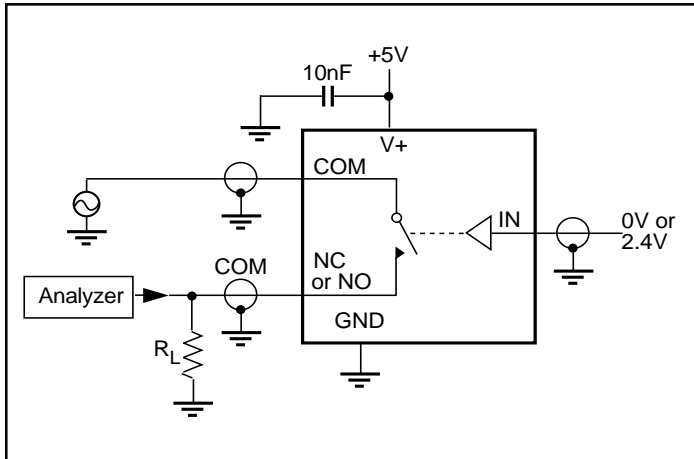

Figure 5. Off Isolation

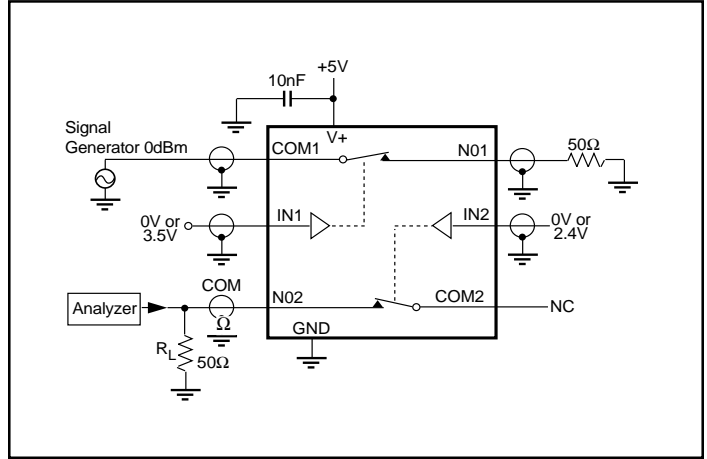

Figure 6. Crosstalk

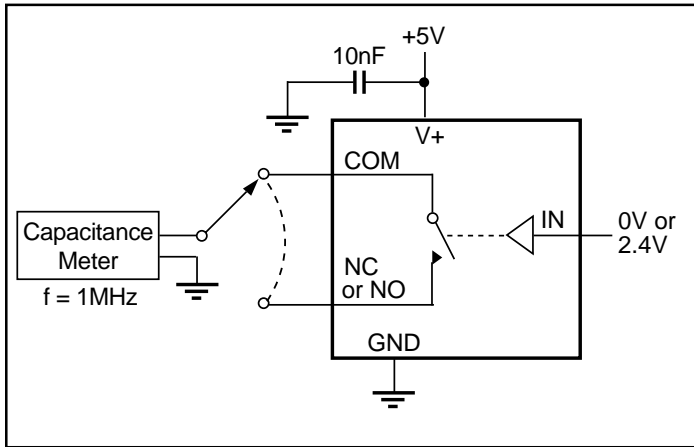

Figure 7. Channel-Off Capacitance

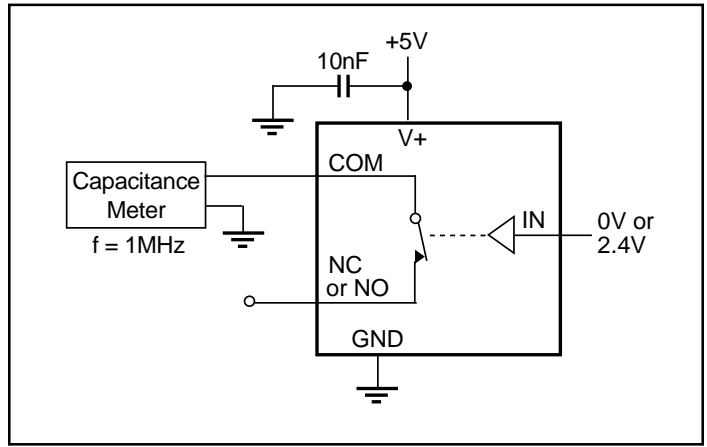

Figure 8. Channel-On Capacitance

Ordering Information

Part	Temp. Range	Package
PS323CPA	0°C to +70°C	8 Plastic DIP
PS323CSA		8 Narrow SO
PS323CUAX		8 MSOP
PS323EPA	-40°C to +85°C	8 Plastic DIP
PS323ESA		8 Narrow SO
PS323EUAX		8 MSOP
PS324CPA	0°C to +70°C	8 Plastic DIP
PS324CSA		8 Narrow SO
PS324CUAX		8 MSOP

Part	Temp. Range	Package
PS324EPA	-40°C to +85°C	8 Plastic DIP
PS324ESA		8 Narrow SO
PS324EUAX		8 MSOP
PS325CPA	0°C to +70°C	8 Plastic DIP
PS325CSA		8 Narrow SO
PS325CUAX		8 MSOP
PS325EPA	-40°C to +85°C	8 Plastic DIP
PS325ESA		8 Narrow SO
PS325EUAX		8 MSOP