

Product Features:

- PI29FCT52/53T is pin compatible with bipolar FAST™ Series at a higher speed and lower power consumption
- TTL input and output levels
- Extremely low static power
- Hysteresis on all inputs
- Industrial operating temperature range: -40°C to +85°C
- Packages available:
 - 24-pin 300 mil wide plastic DIP (P)
 - 24-pin 150 mil wide plastic QSOP (Q)
 - 24-pin 150 mil wide plastic TQSOP (R)
 - 24-pin 300 mil wide plastic SOIC (S)

Product Description:

Pericom Semiconductor's PI29FCT series of logic circuits are produced in the Company's advanced 0.8 micron CMOS technology, achieving industry leading speed grades.

The PI29FCT52T and the PI29FCT53T are 8-bit registered transceivers designed with two 8-bit back-to-back registers to store data flowing in both directions between two bidirectional buses. Separate clock enable and 3-state output enable signals are provided for each register. The PI29FCT52T is a non-inverting option of the PI29FCT53T.

PI29FCT52T and PI29FCT53T Logic Block Diagram

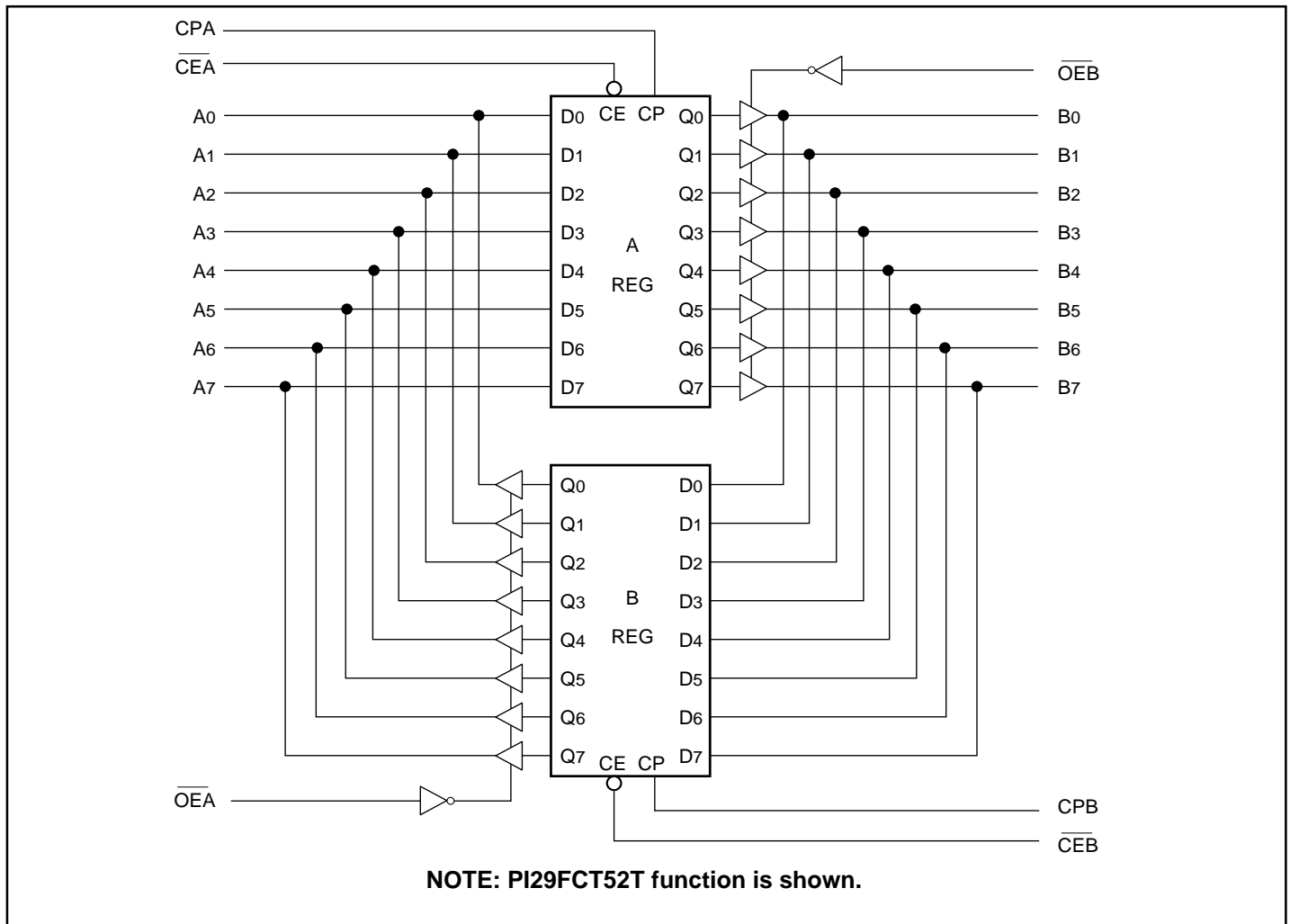

PI29FCT52/53T Product Pin Configuration

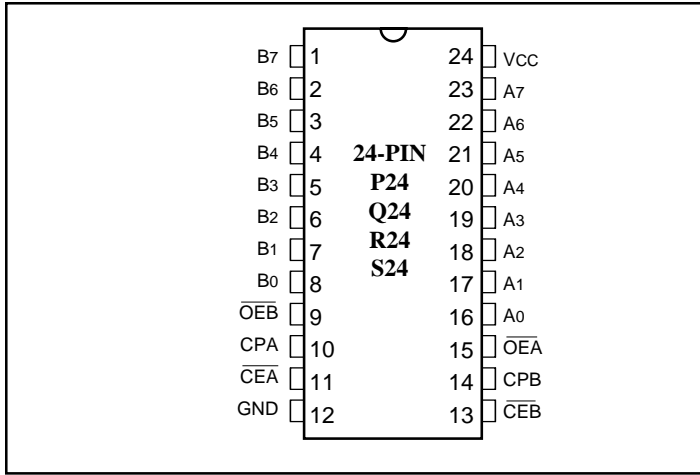

Product Pin Description

Pin Name	Description
A0-A7	A Register Inputs or B Register Outputs
B0-B7	B Register Inputs or A Register Outputs
CPA	Clock for A Register
CPB	Clock for B Register
OE̅A	Output Enable for B Register
OE̅B	Output Enable for A Register
CE̅A	Clock Enable for A Register
CE̅B	Clock Enable for B Register
GND	Ground
Vcc	Power

PI29FCT52/53T Register Truth Table⁽¹⁾
(Applies to A or B Register)

Function	Inputs			Internal
	DN	CP	CE̅	QN
Hold Data	X	X	H	NC
Load Data	L	↑	L	L
	H	↑	L	H

PI29FCT52/53T Output Control Table⁽¹⁾

Function	OE̅	QN	Y-Outputs	
			52	53
Disable Outputs	H	X	Z	Z
Enable Outputs	L	L	L	H
	L	H	H	L

- H = High Voltage Level
 L = Low Voltage Level
 X = Don't Care
 Z = High Impedance
 NC = No Change
 ↑ = LOW-to-HIGH transition

Maximum Ratings

(Above which the useful life may be impaired. For user guidelines, not tested.)

Storage Temperature	-65°C to +150°C
Ambient Temperature with Power Applied	-40°C to +85°C
Supply Voltage to Ground Potential (Inputs & Vcc Only)	-0.5V to +7.0V
Supply Voltage to Ground Potential (Outputs & D/O Only)	-0.5V to +7.0V
DC Input Voltage	-0.5V to +7.0V
DC Output Current	120mA
Power Dissipation	0.5W

Note:

Stresses greater than those listed under **MAXIMUM RATINGS** may cause permanent damage to the device. This is a stress rating only and functional operation of the device at these or any other conditions above those indicated in the operational sections of this specification is not implied. Exposure to absolute maximum rating conditions for extended periods may affect reliability.

DC Electrical Characteristics (Over the Operating Range, TA = -40°C to +85°C, VCC = 5V ± 5%)

Parameters	Description	Test Conditions ⁽¹⁾		Min.	Typ ⁽²⁾	Max.	Units
VOH	Output HIGH Voltage	VCC = Min., VIN = VIH or VIL	IOH = -15.0 mA	2.4	3.0		V
VOL	Output LOW Current	VCC = Min., VIN = VIH or VIL	IOL = 64 mA		0.3	0.55	V
VIH	Input HIGH Voltage	Guaranteed Logic HIGH Level		2.0			V
VIL	Input LOW Voltage	Guaranteed Logic LOW Level				0.8	V
IiH	Input HIGH Current	VCC = Max.	VIN = VCC			1	μA
IiL	Input LOW Current	VCC = Max.	VIN = GND			-1	μA
IOZH	High Impedance	VCC = Max.	VOUT = 2.7V			1	μA
IOZL	Output Current		VOUT = 0.5V			-1	μA
VIK	Clamp Diode Voltage	VCC = Min., IIN = -18 mA			-0.7	-1.2	V
Ios	Short Circuit Current	VCC = Max. ⁽³⁾ , VOUT = GND		-60	-120		mA
IOFF	Power Down Disable	VCC = GND, VOUT = 4.5V		—	—	100	μA
VH	Input Hysteresis				200		mV

Capacitance (TA = 25°C, f = 1 MHz)

Parameters ⁽⁴⁾	Description	Test Conditions	Typ	Max.	Units
CIN	Input Capacitance	VIN = 0V	6	10	pF
COUT	Output Capacitance	VOUT = 0V	8	12	pF

Notes:

1. For Max. or Min. conditions, use appropriate value specified under Electrical Characteristics for the applicable device type.
2. Typical values are at Vcc = 5.0V, +25°C ambient and maximum loading.
3. Not more than one output should be shorted at one time. Duration of the test should not exceed one second.
4. This parameter is determined by device characterization but is not production tested.

Power Supply Characteristics

Parameters	Description	Test Conditions ⁽¹⁾		Min.	Typ ⁽²⁾	Max.	Units
I _{CC}	Quiescent Power Supply Current	V _{CC} = Max.	V _{IN} = GND or V _{CC}		0.1	500	μA
ΔI _{CC}	Supply Current per Input @ TTL HIGH	V _{CC} = Max.	V _{IN} = 3.4V ⁽³⁾		0.5	2.0	mA
I _{CCD}	Supply Current per Input per MHz ⁽⁴⁾	V _{CC} = Max., Outputs Open OEA or OEB = GND One Input Toggling 50% Duty Cycle	V _{IN} = V _{CC} V _{IN} = GND		0.15	0.25	mA/ MHz
I _C	Total Power Supply Current ⁽⁶⁾	V _{CC} = Max., Outputs Open f _{CP} = 10 MHz 50% Duty Cycle OEA or OEB = GND fi = 5 MHz One Bit Toggling	V _{IN} = V _{CC} V _{IN} = GND		1.5	3.5 ⁽⁵⁾	mA
			V _{IN} = 3.4V V _{IN} = GND		2.0	5.5 ⁽⁵⁾	
		V _{CC} = Max., Outputs Open f _{CP} = 10 MHz 50% Duty Cycle OEA or OEB = GND Eight Bits Toggling fi = 2.5 MHz 50% Duty Cycle	V _{IN} = V _{CC} V _{IN} = GND		3.8	7.3 ⁽⁵⁾	
			V _{IN} = 3.4V V _{IN} = GND		6.0	16.3 ⁽⁵⁾	

Notes:

- For Max. or Min. conditions, use appropriate value specified under Electrical Characteristics for the applicable device.
- Typical values are at V_{CC} = 5.0V, +25°C ambient.
- Per TTL driven input (V_{IN} = 3.4V); all other inputs at V_{CC} or GND.
- This parameter is not directly testable, but is derived for use in Total Power Supply Calculations.
- Values for these conditions are examples of the I_{CC} formula. These limits are guaranteed but not tested.
- I_C = I_{QUIESCENT} + I_{INPUTS} + I_{DYNAMIC}
 $I_C = I_{CC} + \Delta I_{CC} D_H N_T + I_{CCD} (f_{CP}/2 + f_i N_i)$
 I_{CC} = Quiescent Current
 ΔI_{CC} = Power Supply Current for a TTL High Input (V_{IN} = 3.4V)
 D_H = Duty Cycle for TTL Inputs High
 N_T = Number of TTL Inputs at D_H
 I_{CCD} = Dynamic Current Caused by an Input Transition Pair (HLH or LHL)
 f_{CP} = Clock Frequency for Register Devices (Zero for Non-Register Devices)
 f_i = Input Frequency
 N_i = Number of Inputs at f_i
 All currents are in milliamps and all frequencies are in megahertz.

PI29FCT52T Switching Characteristics over Operating Range

Parameters	Description	Conditions ⁽¹⁾	29FCT52AT		29FCT52BT		29FCT52CT		Unit
			Com.		Com.		Com.		
			Min	Max	Min	Max	Min	Max	
tPLH	Propagation Delay CPA, CPB, to AN, BN	CL = 50 pF RL = 500Ω	2.0	10.0	2.0	7.5	2.0	6.3	ns
tpHL	CPA, CPB, to AN, BN								
tpZH	Output Enable Time OEA, OEB, to AN, BN		1.5	10.5	1.5	8.0	1.5	7.0	ns
tpZL	OEA, OEB, to AN, BN								
tpHZ	Output Disable Time ⁽³⁾ OEA, OEB, to AN, BN		1.5	10.0	1.5	7.5	1.5	6.5	ns
tPLZ	OEA, OEB, to AN, BN								
tsu	Set-up Time HIGH or LOW, AN, BN to CPA, CPB		2.5	—	2.5	—	2.5	—	ns
th	Hold Time HIGH or LOW, AN, BN to CPA, CPB		2.0	—	1.5	—	1.5	—	ns
tsu	Set-up Time HIGH or LOW, CEA, CEB to CPA, CPB		3.0	—	3.0	—	3.0	—	ns
th	Hold Time HIGH or LOW, CEA, CEB to CPA, CPB	2.0	—	2.0	—	2.0	—	ns	
tw	Pulse Width HIGH ⁽³⁾ or LOW, CPA or CPB	3.0	—	3.0	—	3.0	—	ns	

Notes:

1. See test circuit and wave forms.
2. Minimum limits are guaranteed but not tested on Propagation Delays.
3. This parameter is guaranteed but not production tested.

PI29FCT53T Switching Characteristics over Operating Range

Parameters	Description	Conditions ⁽¹⁾	29FCT53AT		29FCT53BT		29FCT53CT		Unit
			Com.		Com.		Com.		
			Min	Max	Min	Max	Min	Max	
t _{PLH} t _{PHL}	Propagation Delay CPA, CPB, to A _N , B _N	C _L = 50 pF R _L = 500Ω	2.0	10.0	2.0	7.5	2.0	6.3	ns
t _{PZH} t _{PZL}	Output Enable Time OEA, OEB, to A _N , B _N		1.5	10.5	1.5	8.0	1.5	7.0	ns
t _{PHZ} t _{PLZ}	Output Disable Time ⁽³⁾ OEA, OEB, to A _N , B _N		1.5	10.0	1.5	7.5	1.5	6.5	ns
t _{SU}	Set-up Time HIGH or LOW, A _N , B _N to CPA, CPB		2.5	—	2.5	—	2.5	—	ns
t _H	Hold Time HIGH or LOW, A _N , B _N to CPA, CPB		2.0	—	1.5	—	1.5	—	ns
t _{SU}	Set-up Time HIGH or LOW, CEA, CEB to CPA, CPB		3.0	—	3.0	—	3.0	—	ns
t _H	Hold Time HIGH or LOW, CEA, CEB to CPA, CPB		2.0	—	2.0	—	2.0	—	ns
t _w	Pulse Width HIGH ⁽³⁾ or LOW, CPA or CPB		3.0	—	3.0	—	3.0	—	ns

Notes:

1. See test circuit and waveforms.
2. Minimum limits are guaranteed but not tested on Propagation Delays.
3. This parameter is guaranteed but not production tested.