

PBL 3786

Voice-switched Speakerphone and Toner Ringing Circuit

Description

The PBL 3786 contains all the necessary circuitry, amplifiers, detectors, comparators and control functions to implement a high-performance, voice-switched, loud-speaking, "hands-free" telephone. The gain dynamics (attenuation between channels) is continuously adjustable (0 - 50 dB) via a separate pin. A background noise detector in the microphone channel reduces the influence of continuous noise signals.

The PBL 3786 is designed for telephone line powered applications. The circuit contains a transformerless power amplifier with patented current circuitry that eliminates the need for inductors. Automatic volume attenuation extends the operating range at low line voltages.

The PBL 3786 incorporates a high-impedance toner ring with continuously selectable frequencies. The outputs of the toner ring and speech power amplifier use the same loudspeaker, which is switched with a built-in automatic change-over function. The toner ring frequencies can be set either by capacitors or controlled by a microprocessor powered from the chip.

Key features

- Adjustable gain dynamics (0 - 50 dB).
- Direct telephone-line powered (patented).
- Low power consumption, 2.2 mA at 3.2 V (typical).
- Direct drive of 25 - 50 ohm loud-speaker.
- On-chip toner ring with common loudspeaker, automatic switch-over.
- 22-pin dual in-line plastic encapsulation.
- Background noise compensation with hold.
- Minimum of external components.

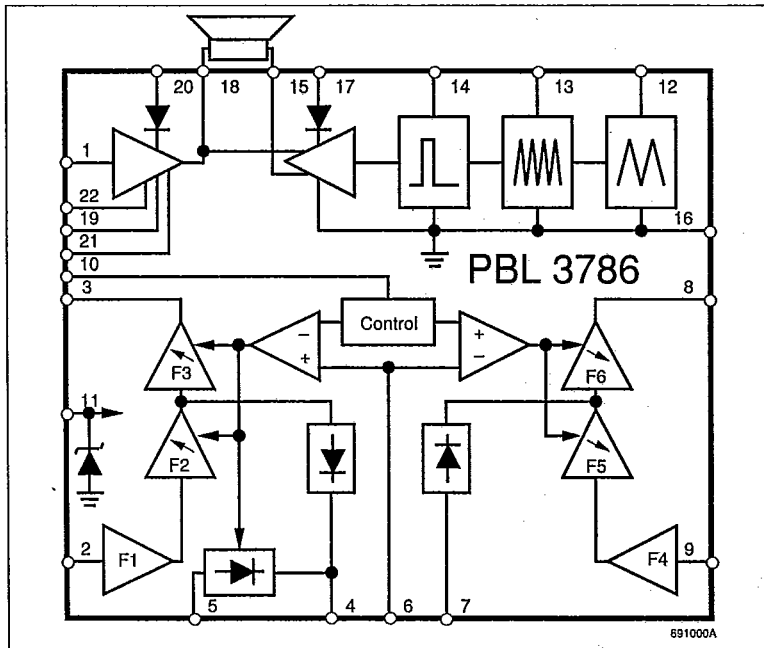
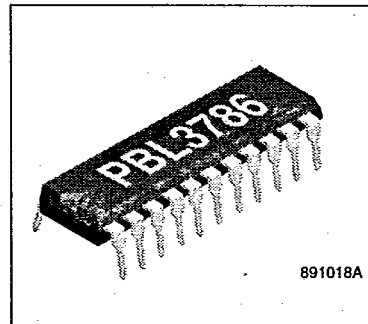

Figure 1. Block diagram.



PBL 3786



T-75-07-15

Maximum ratings

Parameter	Symbol	Min	Max	Unit
Speech switch supply current	I_D		10	mA
Speaker amp supply current	I_{SL}		200	mA
Tone ringer supply current	I_{RVI}		100	mA
Tone ringer supply voltage	V_{RVI}		40	V
Inputs, HF μ PS, LF μ PA, PWM μ PC max voltages			6	V
Operating temperature		0	70	$^{\circ}$ C
Storage Temperature	T_{Stg}	-55	125	$^{\circ}$ C

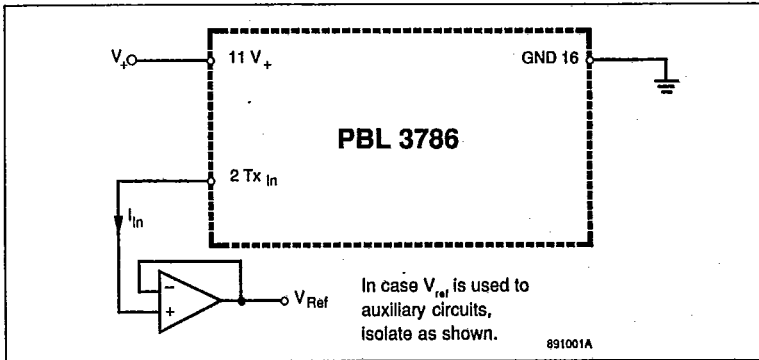

Figure 2.

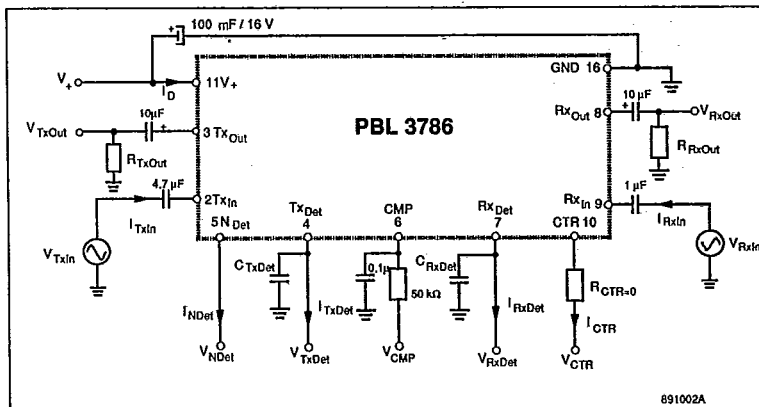

Figure 3.

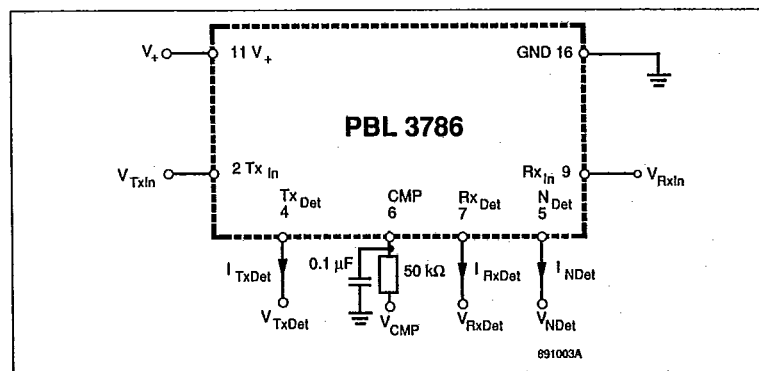

Figure 4.

ERICSSON

PBL 3786

T-75-07-15

Electrical characteristics

 $V_+ = 3.4 \text{ V}$, $f = 1 \text{ kHz}$, $T = 25^\circ$, $C_{\text{TXDet}} = 0$, $C_{\text{RXDet}} = 0$ unless otherwise noted.

Parameter	Ref fig	Conditions	Min	Typ	Max	Unit
Speech control section						
Terminal voltage, V_+	3		3.2			V
Regulator voltage, V_+	3			3.3		V
Internal reference voltage, V_{Ref}	2			1.90		V
Supply current I_d	3	$V_+ = 3.2 \text{ V}$		1.15	1.70	mA
Supply current at power down, I_D	3	$V_{\text{CTR}} < 0.8 \text{ V}$, $V_+ = 3.2 \text{ V}$		0.65	1.30	mA
Frequency response for all amplifiers	3	200 - 3400 Hz, Relative 1 kHz	-1		1	dB
Transmit gain, $20 \cdot 10 \log \cdot (V_{\text{Txout}}/V_{\text{Txin}})$	3	$V_{\text{CMP}} = V_{\text{Ref}} + 0.1 \text{ V}$ $V_{\text{CMP}} = V_{\text{Ref}} - 0.1 \text{ V}$	41.5	44		dB
Receive gain, $20 \cdot 10 \log (V_{\text{Rxout}}/V_{\text{Rxin}})$	3	$V_{\text{CMP}} = V_{\text{Ref}} - 0.1 \text{ V}$ $V_{\text{CMP}} = V_{\text{Ref}} + 0.1 \text{ V}$	26.5	29		dB
Max transmit detector gain, $20 \cdot 10 \log (V_{\text{Txdet}}/V_{\text{Txin}})$	3	$V_{\text{TXDet}} < 200 \text{ mV}_p$ $V_{\text{CMP}} = V_{\text{Ref}} + 0.1 \text{ V}$ $V_{\text{CMP}} = V_{\text{Ref}} - 0.1 \text{ V}$		67.5		dB
Max receive detector gain, $20 \cdot 10 \log (V_{\text{Rxdet}}/V_{\text{Rxin}})$	3	$V_{\text{TXDet}} < 200 \text{ mV}_p$ $V_{\text{CMP}} = V_{\text{Ref}} - 0.1 \text{ V}$ $V_{\text{CMP}} = V_{\text{Ref}} + 0.1 \text{ V}$	22.5	28		dB
Noise rectifier gain, note 1	3	$V_{\text{CMP}} = V_{\text{Ref}} + 0.1 \text{ V}$, $C_{\text{TXDet}} = 1 \mu\text{F}$ $V_{\text{CMP}} = V_{\text{Ref}} - 0.1 \text{ V}$		6.0		dB
Dynamics						
Transmit output, V_{Txout}	3	2% distortion, $R_{\text{TXout}} = R_{\text{RXout}} = 25\text{k}$ $V_+ = 3.5 \text{ V}$		500		mV_p
Receive output, V_{Rxout}	3	$V_+ = 2.9 \text{ V}$ $V_+ = 3.5 \text{ V}$ $V_+ = 2.9 \text{ V}$		250		mV_p
Noise, n						
Transmit output, v_{Txout}	3	$V_{\text{CMP}} = V_{\text{Ref}} + 0.1 \text{ V}$, $v_{\text{TxIn}} = 0 \text{ V}$		-70		dBpsof
Receive output, v_{Rxout}	3	$V_{\text{CMP}} = V_{\text{Ref}} - 0.1 \text{ V}$, $v_{\text{RxIn}} = 0 \text{ V}$		-75		dB
Tx_{In} input impedance, $v_{\text{TxIn}}/i_{\text{TxIn}}$	3		2.5	3.2	3.9	kohm
Rx_{In} input impedance, $v_{\text{RxIn}}/i_{\text{RxIn}}$	3		8	10	12	kohm
Tx_{Det} source current, i_{RxDet}	4	$V_{\text{TxIn}} = V_{\text{Ref}} - 0.1 \text{ V}$, $V_{\text{CMP}} = V_{\text{Ref}} + 0.1 \text{ V}$, $V_{\text{TXDet}} = V_{\text{Ref}}$	2.5	6.0		mA
Rx_{Det} sink current, i_{RxDet}	4	$V_{\text{RxIn}} = V_{\text{Ref}} + 0.1 \text{ V}$, $V_{\text{CMP}} = V_{\text{Ref}} - 0.1 \text{ V}$, $V_{\text{TXDet}} = V_{\text{Ref}}$		-6.0	-2.5	mA
Tx_{Det} sink current, i_{TxDet}	3	$V_{\text{CMP}} = V_{\text{Ref}} + 0.1 \text{ V}$, $V_{\text{TXDet}} = V_{\text{Ref}} + 0.7 \text{ V}$, $V_{\text{TxIn}} = 0$	-30			μA

Figure 5.

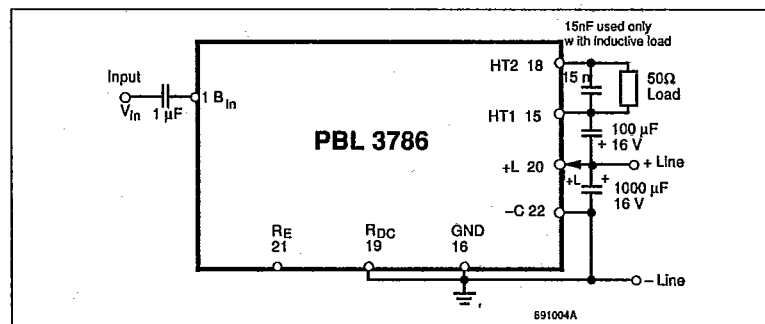

PBL 3786

ERICSSON 

T-75-07-15

Parameter	Ref fig	Conditions	Min	Typ	Max	Unit
Rx _{Det} source current, I _{RxDet}	3	V _{CMP} = V _{Ref} - 0.1 V, V _{RxDet} = V _{Ref} - 0.7 V, V _{RXIn} = 0			30	μA
Tx _{Det} swing relative to V _{Ref} , V _{TxDET}	4	V _{CMP} = V _{Ref} + 0.1 V, V _{TxIn} = V _{Ref} - 0.1 V	(note 2)	+0.7		V
Rx _{Det} swing relative to V _{Ref} , V _{RxDET}	4	V _{CMP} = V _{Ref} - 0.1 V, V _{RXIn} = V _{Ref} + 0.1 V	(note 2)	-0.7		V
N _{Det} source current (fast charge), I _{NDet}	3	V ₊ = 2.7 V, V _{CMP} = V _{Ref} + 0.1 V, V _{NDet} = V _{Ref} - 0.45 V, V _{TxIn} = 0	1.5	4.5		mA
N _{Det} sink current, I _{NDet}	4	V _{CMP} = V _{Ref} + 0.1 V, V _{NDet} = V _{Ref} , V _{TxIn} = V _{Ref} - 0.1 V	-75	-35	-15	μA
N _{Det} leakage current (hold), I _{NDet}	3	V _{CMP} = V _{Ref} - 0.1 V, V _{NDet} = V _{Ref} , V _{TxIn} = 0			-100	nA
N _{Det} swing relative to V _{Ref} , V _{NDet}	4	V _{CMP} = V _{Ref} + 0.1 V, V _{TxIn} = V _{Ref} - 0.1 V		-0.45		V
CMP (comparator) sensitivity, transmit (Tx) mode to receive (Rx) mode or vice versa	3 15	Tx mode = max Tx gain, Rx mode = max Rx gain		100		mV
CTR voltage for full duplex, V _{CTR}	3	V _{CMP} = V _{Ref} ± 0.35 V		V ₊		V
CTR sink current for mute, I _{CTR}	3	V _{CMP} = V _{Ref} ± 0.35 V, R _{CTR} = 1k	50		60	μA
CTR voltage for cutoff, V _{CTR}	3			0.8		V
Loudspeaker amplifier						
Operating voltage, V _{+L}	5		2.5		12	V
Current consumption (no signal), I _{+L}	5	V _{+L} = 3.0 V		1	2	mA
	5	V _{+L} = 5.0 V		1.5		mA
	5	V _{+L} = 12.0 V R _E = 1.5 K,		8	12	mA
	19	+ Line = 3.0 V, V _{RDC} = 0.35 V		1.5		mA
	19	+ Line = 12.0 V, V _{RDC} = 5.0 V		8		mA
Current consumption (output swing at 5% dist.)	5	V _{+L} = 3.0 V		7		mA
	5	V _{+L} = 5.0 V		13		mA
	5	V _{+L} = 12.0 V		30		mA
Swing at 5% dist., V _{Out}	5	V _{+L} = 3.0 V	0.6	0.85		V _p
	5	V _{+L} = 5.0 V	1.5	1.7		V _p
	5	V _{+L} = 12.0 V	3.6	4.5		V _p
Gain,	5	V _{+L} = 5.0 V	34.5	36.5	38.5	dB
Frequency response	5	200 to 3400 Hz, relative 1kHz, V _{+L} = 5.0 V	-1		1	dB
Amplifier power efficiency (5% dist), n	5	V _{+L} = 3.0 to 12.0 V, n = 100 · P _{Load} / P _{Supply}		40		%
Input impedance pin 1	5		24	30	36	kohm

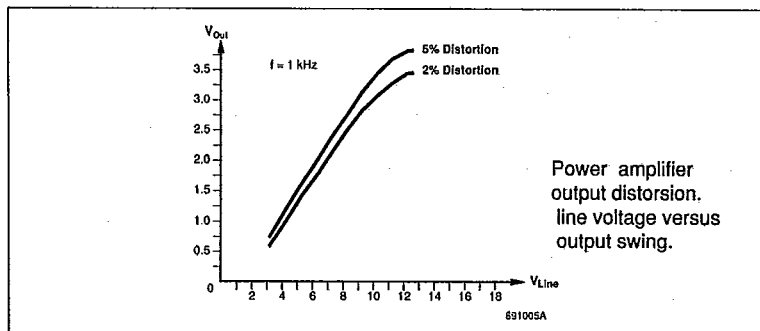

Figure 6.

Parameter	Ref fig	Conditions	Min	Typ	Max	Unit
Tone ringer (Load = 50 ohm resistive, $V_{RVin} = 30$ V unless otherwise noted)						
Supply current pin 17, I_{RVin}	7	$V_{RVin} = 5$ V		1	10	μ A
	7	$V_{RVin} = 10$ V		100	200	μ A
	7	Inductive load (50 ohm loudspeaker)		1.2		mA
	7			2.1	3.3	mA
Threshold voltage on pin 17, V_{RVin}						
Trigger on	7		22	25	28	V
Trigger off	7		16	19	22	V
Hysteresis trigger on/trigger off	7		3	5.5	8	V
Pulsewidth pin 18, t_{pw}	7			12	20	μ s
Frequency modulation (see fig.23), $f1/f2$	7		1.15	1.25	1.35	
Output current on pin 14, $I_{\mu P}$	8	Set by resistor on pin 12		0 to 3.5		mA
Logic levels when interfaced with a microprocessor (at pin 13)						
High logic input level, V_{in}	8		4.2		6.0	V
Low logic input level, V_{in}	8		0.0		0.45	V
Current at high level, I_{in}	8	resistor on pin 12 = 5k	4	7	9	μ A
Current at low level, I_{in}	8	resistor on pin 12 = 5k	-9	-6.5	-4	μ A

Notes

$$1. 20 \cdot \log \left(\frac{V_{NDet} - V_{Ref}}{V_{TxDet} - V_{TxDet0}} \right)$$

V_{NDet} = voltage at noise detector output

V_{Ref} = reference voltage (about 1.9 V)

V_{TxDet} = voltage a transmit detector output

V_{TxDet0} = voltage at transmit detector output at the point the voltage at the noise detector starts moving when a signal at transmit channel input is gradually increased (threshold, typical value 50 mV)

2. Depends on V_{in} . Channels are tracking.

Figure 7.

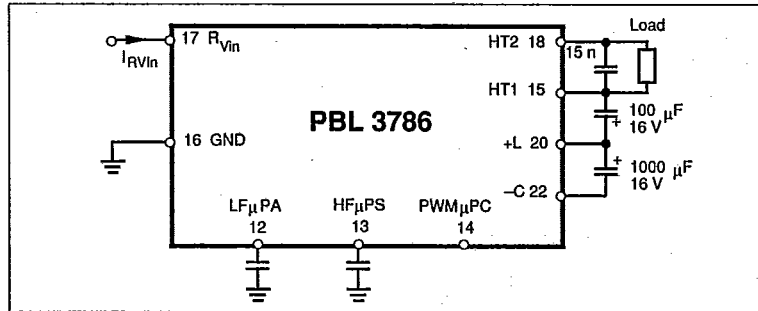
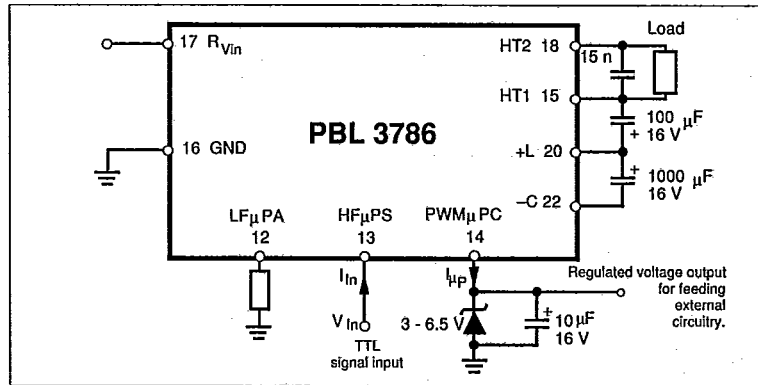

Figure 8.



PBL 3786

ERICSSON

T-75-07-15

Pin Descriptions

Refer to figure 9. (22-pin dual-in-line package)

Pkg	Symbol	Description
1	B _{In}	Signal input loudspeaker amplifier. Input impedance 30 kohm.
2	Tx _{In}	Transmit channel input. Input impedance 3.2 kohm.
3	Tx _{Out}	Transmit channel output. Minimum load impedance 25 kohm.
4	Tx _{Det}	Transmit channel detector output. Goes positive in reference to the internal reference voltage when signal is present at Tx _{In} , approximately 1.9 V.
5	N _{Det}	Background noise detector output. Goes negative when a noise of longer duration appears at Tx _{In} .
6	CMP	Comparator input. External resistance to this input should be 50 kohm. Summing point to the different detector outputs.
7	Rx _{Det}	Receive channel detector output. Goes negative in reference to the internal reference voltage when signal is present at Rx _{In} , approximately 1.9 V.
8	Rx _{Out}	Receive channel output. Minimum load impedance 25 kohm.
9	Rx _{In}	Receive channel input. Input impedance 10 kohm.
10	CTR	Control input for gain dynamics, mute, and power down.
11	V _t	Supply for the speech-switching circuitry. A shunt regulator sets the voltage to approximately 3.2 V at 1 mA.
12	LF _μ PA	Low-frequency tone ringer oscillator set by a capacitor (shift frequency), μP mode, see text.
13	HF _μ PS	High-frequency tone ringer oscillator set by a capacitor. μP mode, see text.
14	PWM _μ PC	Tone ringer volume control. μP mode, see text.
15	HT1	Loudspeaker ground switch for tone ringer.
16	GND	Ground for the whole system (-line).
17	R _{VIn}	Supply for the tone ringer and it's output stage.
18	HT2	Common output for loudspeaker and tone ringer power amplifiers.
19	R _{DC}	These inputs allow the supply to the loudspeaker amplifier to be used
21	R _E	in two different ways, described in text.
22	-C	
20	+L	

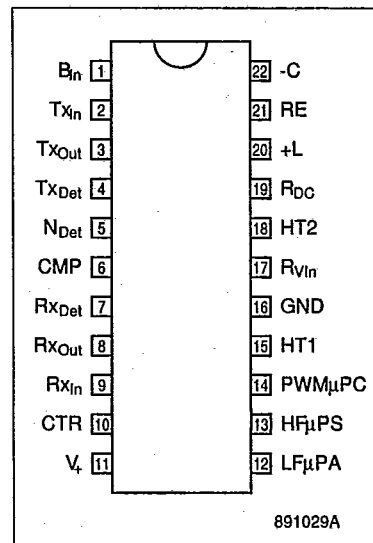

Figure 9. Pin configuration

Functional description**Speech control section****Transmit and receive channels**

The transmit and receive channels consist of three amplifying stages each, F1, F2, F3 and F4, F5, F6. The inputs and outputs of the amplifiers must be AC-coupled.

F1 and F4 are fixed-gain amplifiers of 30 dB respectively 20 dB, while the rest are of controlled-gain type.

The gain of F2 and F3, as well as F5 and F6, is controlled by comparators. The comparators receive their information partly from the summing point of the transmit, receive, and noise detectors; the CMP input; and partly through the control input, CTR, which controls the gain dynamics. Amplifiers F2 and F3 have the maximum gain when the transmit channel is fully open, consequently F5 and F6 will have minimum gain. When F5 and F6 have maximum gain, the receive channel is fully open and the amplifiers F2 and F3 are at minimum gain. See figure 10.

Signal detectors and comparators

The signal detectors sense and rectify the signals to opposite polarities, referenced to the internal reference voltage of approximately 1.9 V. The voltage at $R_{x_{Det}}$ will go negative and at $T_{x_{Det}}$ positive, in the presence of a signal at the respective channel input.

In the idle (no signal) position, the voltage at $R_{x_{Det}}$, $T_{x_{Det}}$, and consequently CMP is equal to the internal reference voltage (approximately 1.9 V).

Signal at $T_{x_{in}}$ will result in an increased level at $T_{x_{Det}}$ and hence also at CMP. The comparators will now increase the gain in the transmit channel and decrease it in the receiving channel. Signal at $R_{x_{in}}$ will affect the levels and gain setting in the opposite way. Maximum input current to CMP is 1 μ A.

The voltages $R_{x_{Det}}$ and $T_{x_{Det}}$ are used to control the gain setting in the respective channel through comparators, where the CMP input is the summing point. The attack and decay times for signals at $R_{x_{Det}}$ and $T_{x_{Det}}$ are controlled by individual external RC networks. The attack time in the R_x channel is set by the capacitor, C2, and either by the maximum current capability of the detector output, or by the external resistor, R2, in series

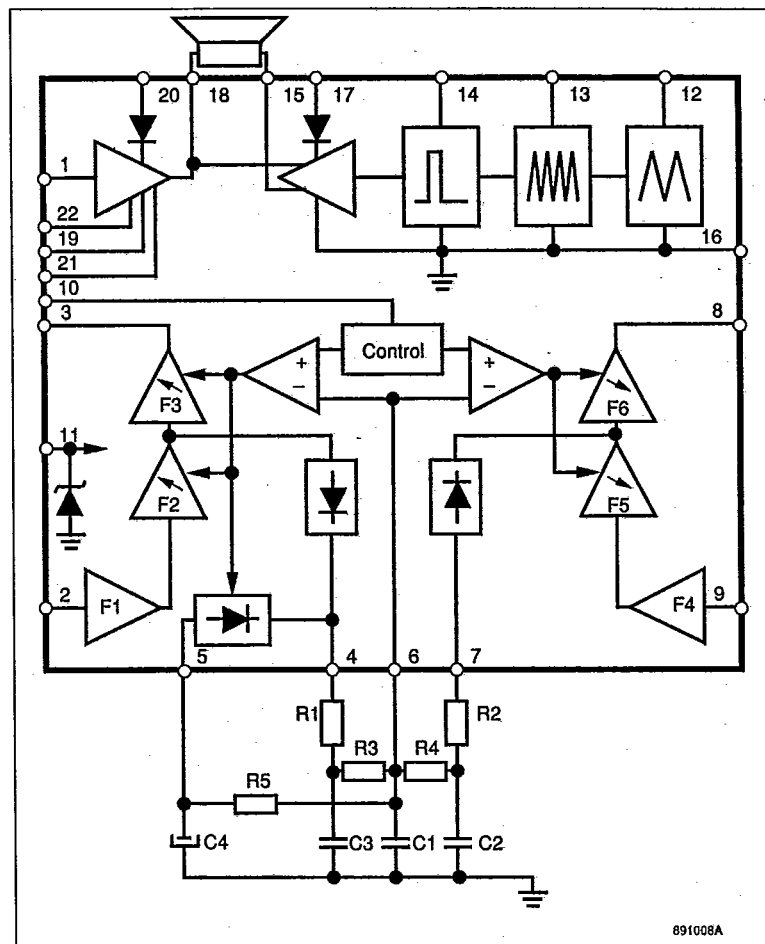

Figure 10.

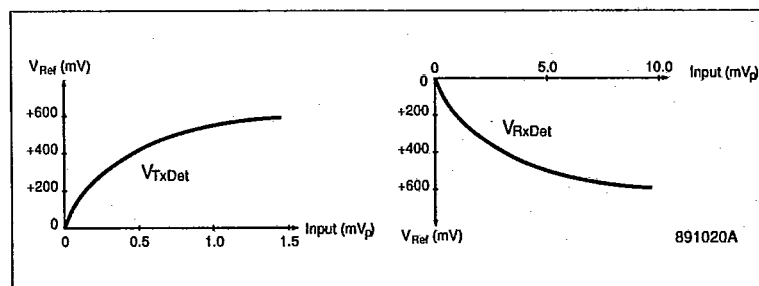

Figure 11. Transmit- and receive-channel rectifier characteristics.

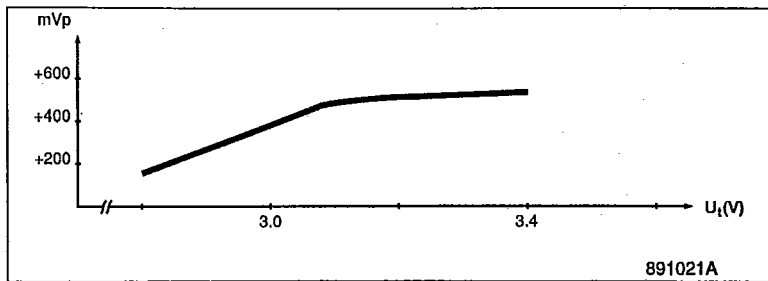

Figure 12. Transmit and receive output dynamics.

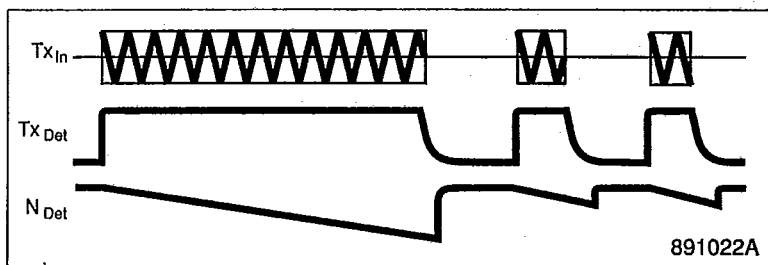

Figure 13. Relationship between the voltage levels at TX_{in} , TX_{Det} and $NDET$.

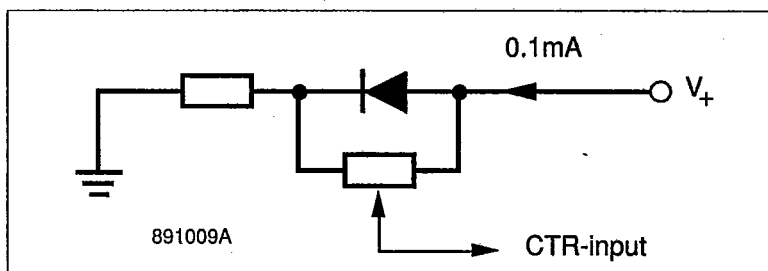

Figure 14. The control input voltage, from full duplex to full speech control.

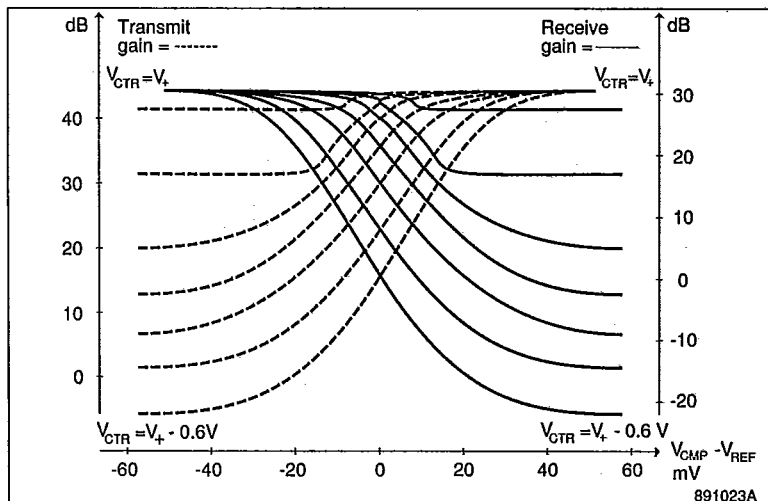

Figure 15. Transmit and receive gain as a function of V_{CMP} and V_{REF} .

ERICSSON
PBL 3786
T-75-07-15

with the detector output. The RC network in the T_x channel is composed of R1, C3. See figure 10.

The decay times of the receive and transmit channels are set by C3 and C2, respectively, and an internal 100 kohm resistor, in parallel with the external resistors (R1R3 and R2R4, respectively) connected to the CMP input. C2 and C3 should be dimensioned for a charge time of 0.5 to 10 ms and for 150 to 300 ms discharge time. The total external resistance to the CMP input should be 50 kohm, therefore the resistors, R3, R4 are to be 100 kohm.

A hysteresis effect is achieved in the switching, since the level detectors sense the signals after F2 and F5 respectively (F2 and F5 are affected by the gain setting). For example, if the transmit channel is open (maximum gain), a smaller signal at $T_{x_{in}}$ is needed to keep the channel open than would be needed to open it when the receive channel was open.

The output swing of the level detectors is matched for variations in the supply voltage. The detectors have a logarithmic rectifier characteristic, the gain, and thereby the sensitivity, is high at low signals. There is a break point, at about 200 mV from the reference, where the sensitivity for increasing input signals decreases 10 times. This gives increased dynamics for the detectors. See figure 11.

Background noise detector

The general function of the background noise detector is to create a negative signal (in respect to the reference) that, when coupled to the summing point at the CMP input, will counteract the signal from the transmit level detector to an extent representing the actual noise level. This prevents the noise from influencing the switching comparators.

The input signal to the background noise level detector is taken from the output of the transmit detector, a signal representing the envelope of the amplified microphone signal, except for the part of it that decreases faster than C3, on the output of $T_{x_{det}}$ discharges. The detector amplifies the inversion of this signal about 2 times (transmit mode) and drives an RC-net consisting of an internal resistor of 100 kohms and an external capacitor, C4. The voltage over C4 is coupled to the CMP input via resistor R5. The extent to which the N_{det} output will influence the

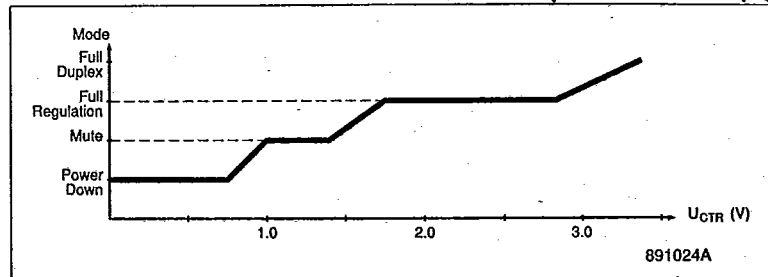

Figure 16. Gain dynamics control at $V_s = 3.4 V$.

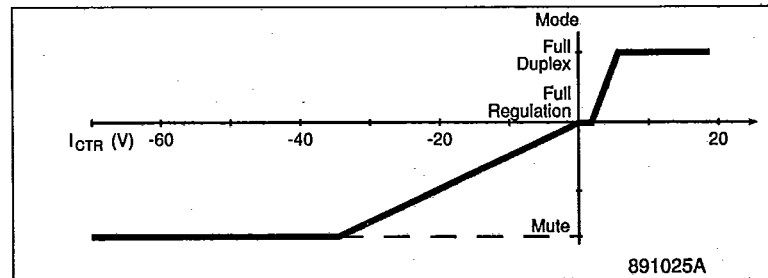

Figure 17.

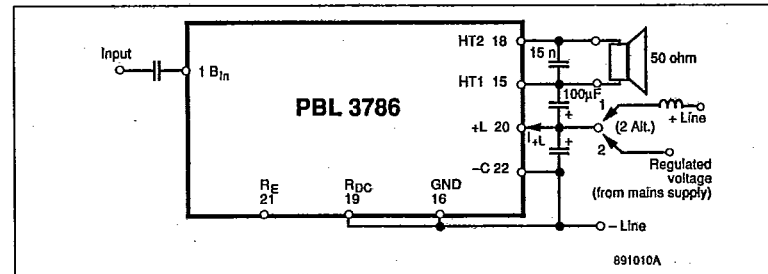

Figure 18.

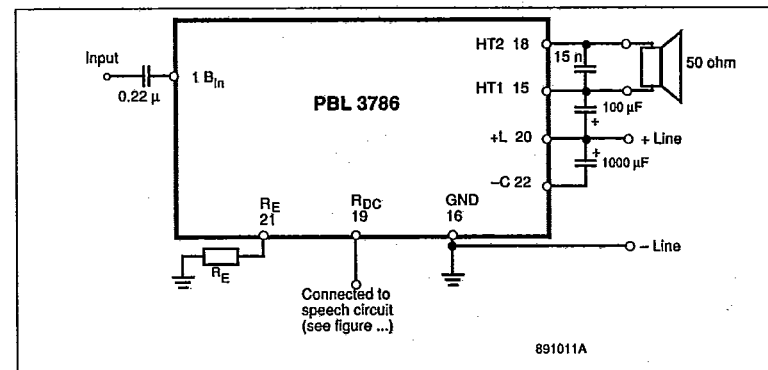

Figure 19.

PBL 3786

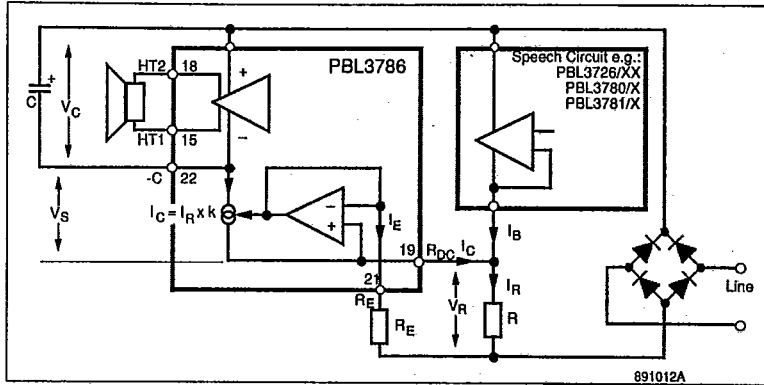

Figure 20. Current biasing regulated by the speech circuit working in parallel with PBL 3786.

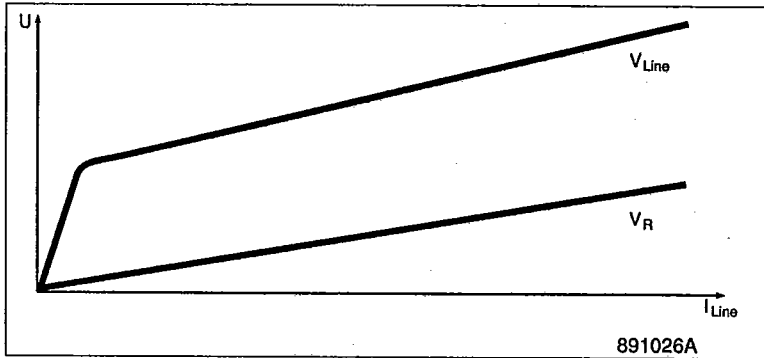

Figure 21. Speech circuit DC characteristics.

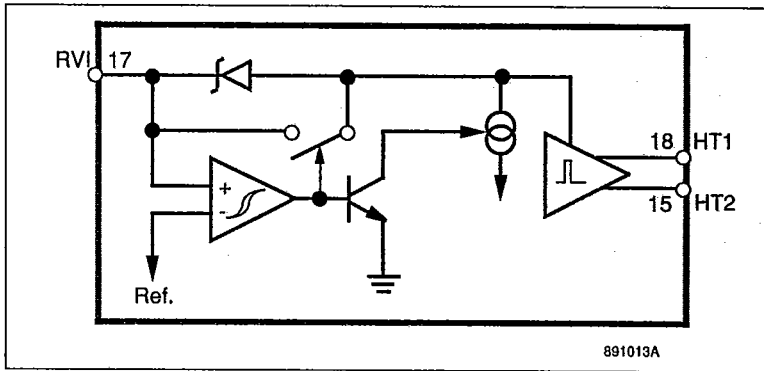

Figure 22. Toner ring threshold circuit.

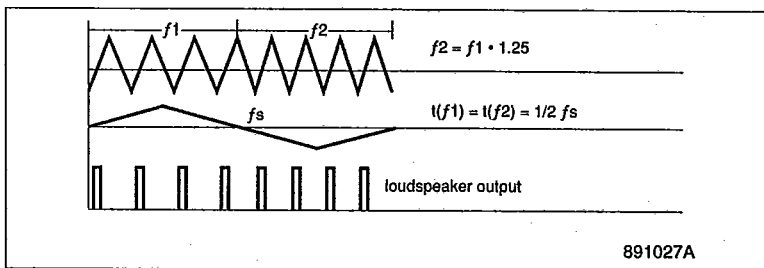

Figure 23.

potential at the CMP input is set by the gain of the detector, the maximum swing, and R5.

If a constant-input signal, a signal with no longer breaks, is received from the microphone, the voltage over C4 is pulled in a negative direction (relative to the reference) with a time constant set by C4 to e.g. 4 - 5 s. A continuous input signal is thereby treated as noise. Since the output of the noise detector is going negative, it thereby counteracts the voltage from Tx_{Det} in the summing point at CMP.

If the input signal contains breaks like breath pauses, the voltage at Tx_{Det} output decreases. If the voltage over C3 becomes less than the voltage over C4 divided by the gain of the detector (absolute values), the detector starts a rapid charge of C4, up toward the reference voltage. If the breaks are frequent enough (typical speech), the background noise detector will not influence the switching of the comparators. See figure 13.

At T_{Det} there is a threshold (approximately 50 mV) to prevent the activation of noise detection in noiseless surroundings.

In the receive mode, some of the loudspeaker output signal will be sensed by the microphone. In order not to treat this transmit input signal as noise, the noise detector goes to a "hold" state in this mode, and "remembers" the level of the former transmit or standby mode.

CTR Input

A voltage at this input (normally V₋ - 600 mV) controls the comparators which set the gain in the receive and transmit channels continuously from full speech control mode (50 dB attenuation between channels) to duplex mode (both channels fully open). Input left open renders full speech control. See figures 14 and 15.

In full duplex mode, the CMP input is clamped to the reference voltage in order not to let this level interfere with the function.

If current is drained out of the input, the gain is reduced in both channels, and a mute mode is achieved (at approximately 35 - 40 μ A). See figure 17.

Decreasing the voltage at the input below 0.9 V, a shut-down state is reached, where the transmit and receive amplifiers are switched off and the current consumption is reduced. See figure 16.

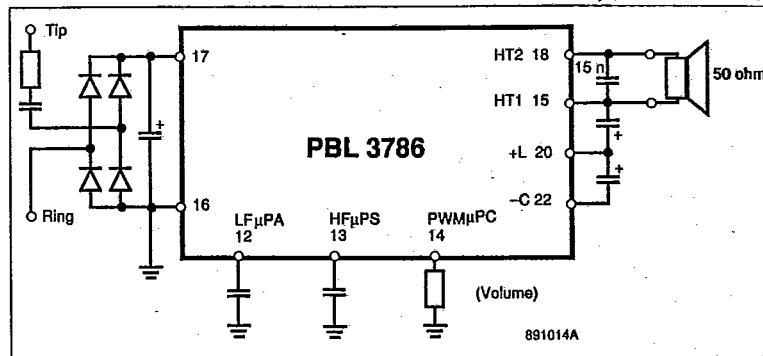

Figure 24. Basic Application.

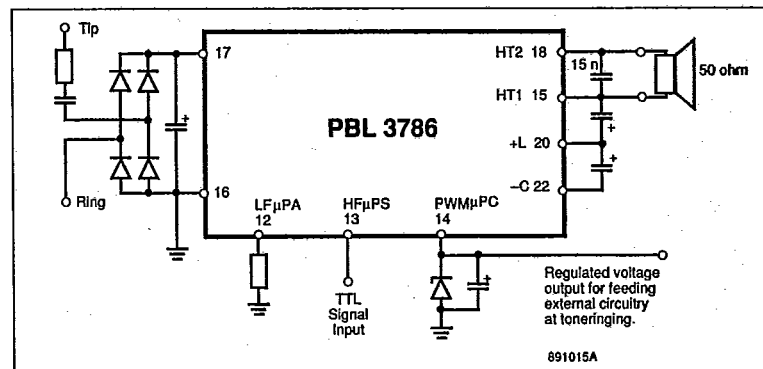

Figure 25. Application with external microprocessor.

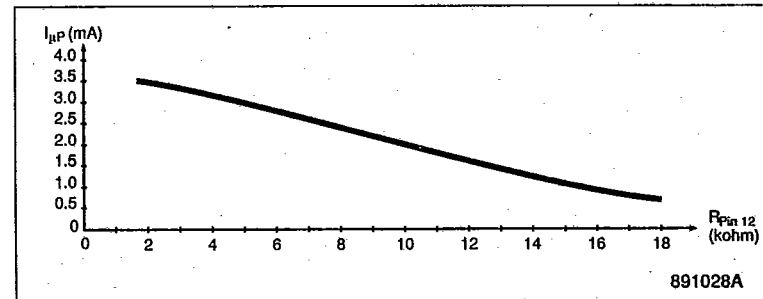

Figure 26. Output current on pin 14, Toneriger μ -processor mode (fig. 42).

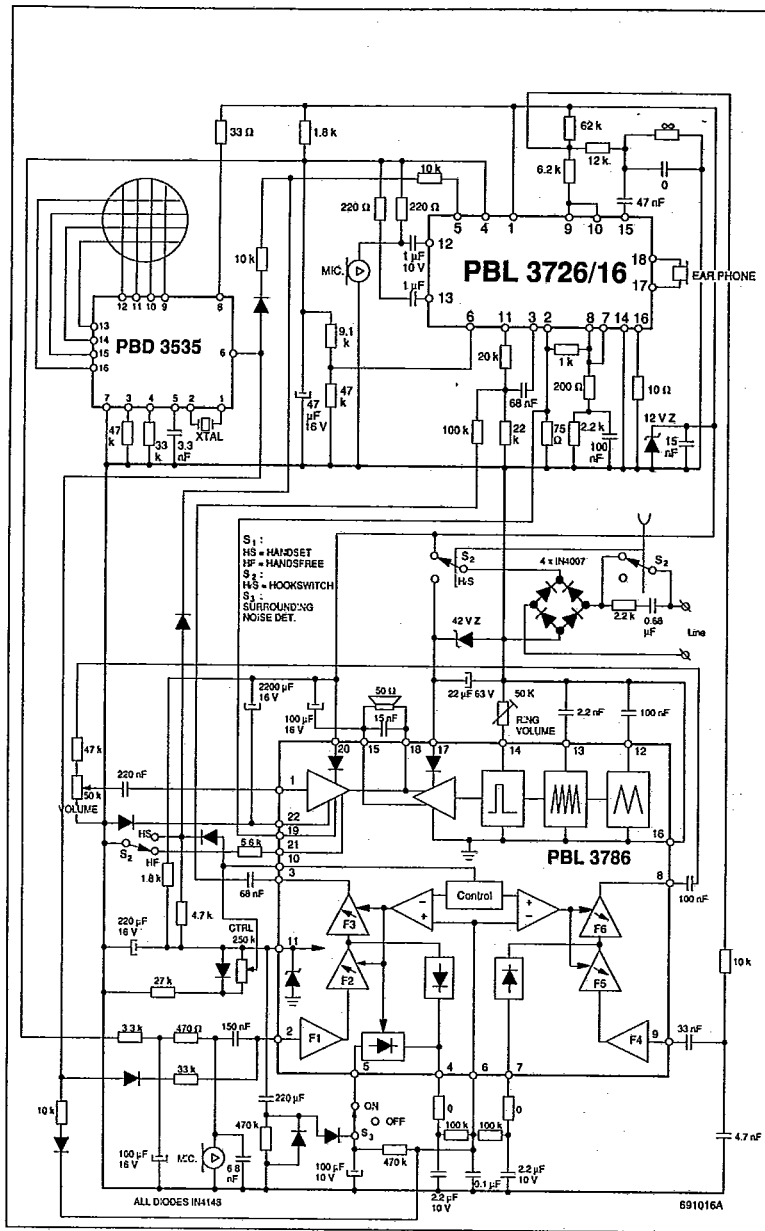

Figure 27. Application 1.

Loudspeaker amplifier

The loudspeaker amplifier directly drives the 50 ohm loudspeaker, which is also used by the tone ringer. The amplifier is designed to work in a number of different biasing applications.

The highest output swing is obtained if pin -C is connected to ground and pin +L is connected to a stable supply. The biasing could be provided either from the mains supply or via a coil from the telephone lines. See figure 18. Current consumption is directly proportional to the voltage between pins +L and -C.

When using the application according to figure 19, pin -C is used as a negative floating-point supply for the amplifier. The output signal of the loudspeaker amplifier is referred to +L. The capacitor, C, makes it possible for the amplifier to handle peaks which are above its constant-drive capability.

The optimal design, without using a stable supply, is to balance the biasing of the circuit against the DC characteristics of the speech circuit working in parallel. See figure 20. In figure 20, the capacitor, C, is a charge reservoir for the loudspeaker amplifier. The maximum current, I_{CMax} , that can charge C, is set by R_E and the voltage, V_R . At a certain voltage, V_R , I_E is given by:

$$I_D = V_R / R_E = k_1 \cdot I_R$$

This current is multiplied in the hands-free circuit and $I_{CMax} = k \cdot I_R$ (k must be < 1). The capacitor, C, is charged until the voltage, V_C , is equal to the voltage across the speech circuit, i.e. $V_S = 0$.

The speech circuit sets the DC characteristics. See figure 21. At a specific supply condition, the current, I_{R1} , is therefore kept constant. Since $I_R = I_C + I_B$ is constant, the resistor, R_E , must be chosen so that it ensures the minimum operating current for the speech circuit at all conditions.

The single-ended loudspeaker amplifier has an internal gain regulation which prevents distortion in cases when enough current from the line is not available.

PBL 3786**ERICSSON** 
T-75-07-15**Ordering Information**

Package	Temp. Range	Part No.
Plastic DIP	-20 to 70°C	PBL 3786N

Information given in this data sheet is believed to be accurate and reliable. However no responsibility is assumed for the consequences of its use nor for any infringement of patents or other rights of third parties which may result from its use. No license is granted by implication or otherwise under any patent or patent rights of Ericsson Components AB. These products are sold only according to Ericsson Components AB' general conditions of sale, unless otherwise confirmed in writing.

Specifications subject to change without notice.

IC4 (88094) B-Ue

© Ericsson Components AB 1987

ERICSSON 

Ericsson Components AB
S-164 81 Kista-Stockholm, Sweden
Telephone: (08) 757 50 00