

TOSHIBA

PRODUCT GUIDE

Photo Couplers and Photo Relays



2004 semiconductor
<http://www.semicon.toshiba.co.jp/eng>

Preface

Recently photocouplers have been one of the most popular isolation devices used for noise protection in various electronic equipment.

TOSHIBA's photocouplers incorporate into a white mold package, a combination of either GaAs infrared LEDs or GaAlAs infrared LEDs and silicon photo-detectors. GaAlAs LEDs are adopted in the high-speed photo-IC types by utilizing their features of high speed and high light power. Also, TOSHIBA's innovative white mold packaging results in high sensitivity, excellent efficiency, and superb reliability.

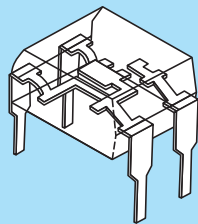

Perspective view of the TLP521-1

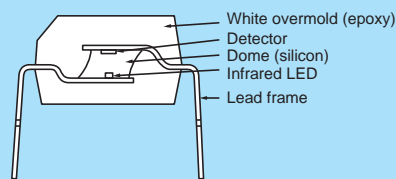

Cross section of the TLP521-1

Extensive Line of Products

To meet the customers' various needs, TOSHIBA offers an extensive line of products shown below as well as general-purpose photocouplers.

1. Photo-IC couplers: High speed and advanced functions (Highly-integrated detectors)
2. Zero-crossing phototriac couplers: Phototriac output devices with zero-crossing function
3. AC power couplers: High output current (used with a power triac)
4. Photovoltaic couplers: MOSFET gate drive (high voltage output achieved using a photodiode array)
5. Photorelays (MOSFET output devices): AC/DC switches (MOSFET output)
Mechanical relay replacement

Safety Standard Approvals

UL recognition in File No. E67349 has been obtained on most of TOSHIBA's photocouplers. EN60747-5-2 approved photocouplers are also supplied along with a wide selection of output (transistor, thyristor, triac, IC output and photorelay). The designs of these devices meet other standards including IEC380/VDE0806, IEC60950/EN60950 and IEC60065/EN60065.

Small-Package Products

TOSHIBA offers a wide variety of small packaged photocouplers to meet requirements for size reduction and space savings in smaller electronic equipment. The devices include Mini-flat packaged (MFSOP) products and half-pitch (1.27 mm) mini-flat SOP packaged products.

Overseas Manufactured Photocouplers

TOSHIBA semiconductor Thailand manufactures general-purpose 4-pin phototransistor output devices to help customers to easily procure components for overseas assembly of end products.



Contents

1. New Products	p. 4
2. Photocoupler Product Tree	p. 8
3. Recommended Products.....	p.10
4. Selection Guide.....	p.12
5. Package Information.....	p.36
6. Supplementary Information.....	p.51
7. Safety Standard Approved Photocouplers	p.58
8. Photocoupler Application Circuit Example	p.61
9. Competitor Cross Reference	p.77
10. Discontinued and Final-Phase Products	p.79

1 New Products

20-Mbps High-Speed, and Low-Power-Consumption Photo-IC Output Coupler: TLP116

The TLP116, high performance photo-IC output couplers, is housed in a mini-flat package that realized one third lower power consumption and twice faster switching speed than those of the conventional high-speed photo-IC coupler, TLP115A. 20 Mbps switching speed was achieved, furthermore, bidirectional drive for the sink and source is possible because of the totem pole output structure. The maximum operating temperature of 100°C allows the TLP116 can be used in various applications such as plasma displays, measurement instruments, control equipment and factory automations.



Characteristics	TLP115A (Conventional product)	TLP116 (New product)
Propagation delay time t_{pHL}/t_{pLH} [ns] (max)	120 ns ($T_a = 25^\circ\text{C}$)	60 ns ($T_a = -40$ to 100°C)
Supply current I_{CC}/I_{CCH} [mA] (max)	19 mA / 15 mA ($T_a = 0$ to 70°C)	5 mA / 5 mA ($T_a = -40$ to 100°C)
Supply voltage V_{CC} [V]	4.5 to 5.5 V	4.5 to 5.5 V
Operating temperature T_{opr} [°C]	-40 to 85°C	-40°C to 100°C
Threshold input current (max) I_{FHL} [mA]	5 mA ($T_a = 0$ to 70°C)	5 mA ($T_a = -40$ to 100°C)
Common mode transient immunity [min] CML/CMH [kV/us] ($T_a = 25^\circ\text{C}$)	± 1 kV/ μs	± 10 kV/ μs
Isolation voltage [min] BVs [kVrms] ($T_a = 25^\circ\text{C}$)	2.5 kVrms	3.75 kVrms

Photo-IC Output Couplers with New Package SDIP

The devices housed in a Shrink Dual Inline Package (SDIP) meet the requirements for reinforced insulation. Small photo-IC output couplers, meeting the international safety standards, were housed in a widely used 8-pin DIP package; however, housing these devices in newly developed SDIP package can reduce mounting area to 50% than that of the conventional package. TOSHIBA has newly lined up four types of devices with this package, high-speed photo-IC couplers for data transfer, IGBT/MOSFET, IPM and general-purpose photo-IC.



- 6-pin SDIP (50% smaller than 8-pin DIP package)
- SMD
- International safety standards: UL-approved, TUV(EN60747-5-2) design which meets safety standard
- Isolation voltage: BVs = 5000 Vrms (min)
- Structure parameters

	7.62-mm pitch TLPxxx	10.16-mm pitch TLPxxxF
Creepage distance	7.0 mm (min)	8.0 mm (min)
Clearance	7.0 mm (min)	8.0 mm (min)
Isolation thickness	0.4 mm (min)	0.4 mm (min)

Package Dimensions and Characteristics

Part Number	Data Rate or t_{pHL}/t_{pLH} (typ.)	Output	Device Type
TLP701	0.25 μs	± 0.6 A peak current	IGBT/MOSFET direct drive
TLP716	45 ns	Totem pole output	High-speed data transfer
TLP719	1 Mbit/s	CTR 20% (min)	General-purpose

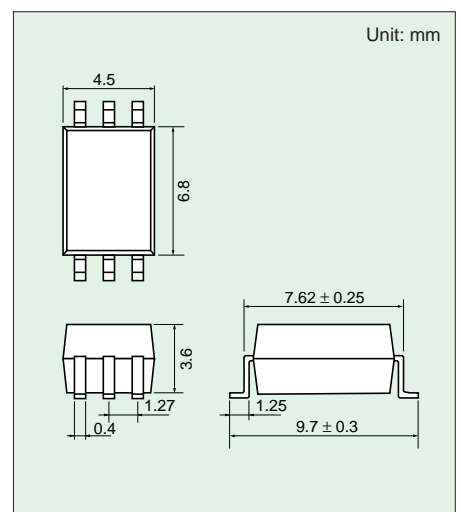

Phototriac Couplers with 4-pin DIP: TLP360J and TLP361J

New TLP360J and TLP361J are smaller phototriac couplers housed in a 4-pin DIP package compared to a 6-pin DIP package of the conventional TLP3052(S) and TLP3063(S).

The inhibit voltage of the zero-cross type TLP361J is reduced to 50% or less than that of the TLP3063(S), $V_{IH} = 50 \rightarrow 20$ V; therefore, turn-on noise is also reduced. These new products are suitable for use in office equipment, triac drivers and solid state relays.

- Compact package: 4-pin DIP
- Peak off-state voltage: 600 V (min)
- On-state current: $I_T = 0.1$ Arms (max)
- Isolation voltage: $BVs = 5000$ V (min)
- Inhibit voltage: $V_{IH} = 20$ V (max) (TLP361J)
- International safety standards
UL-approved, VDE(TUV)-approved, BSI*, SEMKO*

*: Approval pending



Pin Configuration

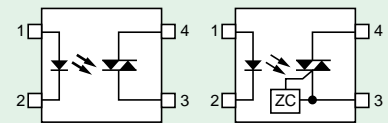

TLP360J:
non zero-cross

TLP361J:
zero cross

Photorelays for Testers and Measurement Instruments, Low CR Photorelays: TLP31xx Series and TLP32xx Series

The new TLP31xx series and TLP32xx series photorelays exhibit lower output pin capacitance (C_{OFF}) and on-resistance (R_{ON}) than conventional devices. In addition, they feature CR values of 5 pFΩ and 10 pFΩ which are approximately equivalent to those of reed relays. These photorelays have been developed in response to requirements for high-speed operation, high reliability, smaller component size and environmental safety (such as calls for an end of the use of mercury). Such characteristics are required for testers and measuring instruments which are used for testing semiconductor products (which by their nature are evolving at a rapid pace). Besides, the TLP32xx series is housed in the smallest package, 4-pin SSOP in the industry and can be achieved high-density mounting, 50 devices/inch².

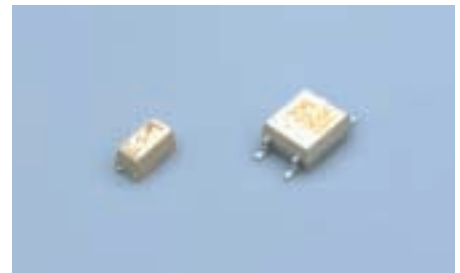

Part Number		Off-State Voltage V _{off} (V) (min)	On-State Current I _{on} (mA) (max)	On-State Resistance R _{on} (Ω) (typ.)	Off-State Capacitance C _{off} (pF) (typ.)	Trigger Current I _{FT} (mA) (max)
2.54SOP4 package	SSOP4 package					
TLP3113	TLP3213	40	80	25	0.6	4
TLP3114	TLP3214		250	2	5	
TLP3115	TLP3215		300	1	10	
TLP3116	TLP3216		120	10	1	
TLP3130	TLP3230	20	160	5	1	
TLP3131	TLP3231		300/450*	1	5	

*: TLP3131: I_{on} = 300 mA (max), TLP3231: I_{on} = 450 mA (max)

1 New Products

Low-Cost Photorelays: TLP222A and TLP222G Series

The new TLP222A series has achieved high cost effectiveness with a switching trade-off while retaining the current ratings of the conventional TLP227A series photorelays. The new TLP222G series also has achieved high cost effectiveness by providing a trade-off for higher On-resistance compared with the conventional TLP227G series.

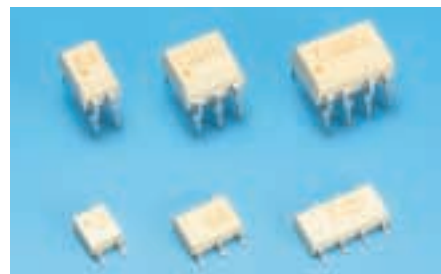

Part Number			Package	Off-State Voltage V _{off} (V)	On-State Current I _{on} (mA) (max)	On-State Resistance R _{on} (W) (max)	Switching t _{ON} / t _{OFF} (ms) (max)
4-pin, 1-channel	6-pin, 1-channel	8-pin, 2-channel					
TLP222A	TLP592A	TLP222A-2	DIP	60	500	2	2.0/0.5
TLP172A	TLP192A	TLP202A	SOP		400	2	
TLP222G	TLP222G	TLP222G-2	DIP	350	120	50	1.0/1.0
TLP172G	TLP192G	TLP202G	SOP		110	50	

Photorelays for Testers, Measurement Instruments and Power Line Controls: TLP3120 and TLP3542

The new TLP3120 and TLP3542 are photorelays, used for limiting high-load current, that can reduce On-resistance to 0.15 Ω and 0.10Ω (max) respectively. Especially for the TLP3542, this new device guarantees on-state current of 2 A even when ambient temperature is as high as 60°C.

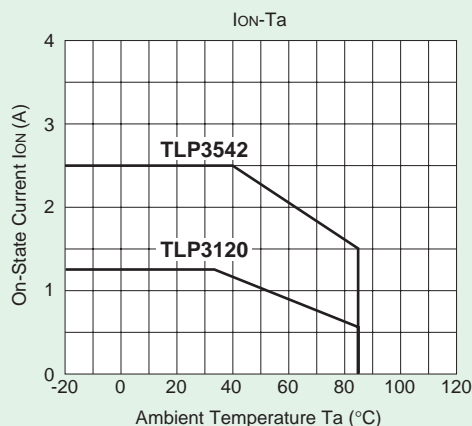

Part Number	Package	Operating Temperature Range (°C)	Off-State Voltage V _{off} (V)	On-State Current I _{on} (A) (max)	On-State Resistance R _{on} (mΩ) (typ.)	Off-State Capacitance C _{off} (pF) (typ.)
TLP3120	2.54SOP6	-20 to 85	80	1.25	110	460
TLP3542	DIP6		60	2.5	65	400

Photo-IC Coupler for IGBT/MOSFET Gate Drive: TLP350

The TLP350, photo-IC coupler, realizing that the lowest power consumption in the industry by employing the Bi-CMOS process, is housed in an 8-pin DIP package and can directly drive medium-power IGBT. This new device is significant for reducing set's power consumption because of the supply current reduction by 80% compared to that of the TLP250. As a result, heat dissipation from the chip is also reduced, and 100°C maximum rating of operating temperature guarantee is achieved. The TLP350 can be used in various applications such as inverters for air conditioners, general-purpose inverters, AC servo motors and plasma displays.



Characteristics	TLP250 (Conventional Product)	TLP350 (New Product)
Output current $I_{OPH}/I_{OPL}(\max)$	± 1.5 A	± 2.5 A
Supply voltage $V_{CC}(\max)$	35 V	35 V
Supply current $I_{CCH}/I_{CCL}(\min)$	11 mA (-20 to 70°C)	2 mA (-40 to 100°C)
Propagation delay time $t_{pHL}/t_{pLH}(\max)$	500 ns (-20 to 70°C)	500 ns (-40 to 100°C)
Operating temperature $T_{opr}(\text{°C})$	-20 to 85°C	-40 to 100°C
Threshold input current $I_{FH}(\max)$	5 mA (-20 to 70°C)	5 mA (-40 to 100°C)
Common mode transient immunity $CMH/CM_L(\min)$ ($T_a = 25\text{°C}$)	± 5 kV/ μs	± 15 kV/ μs
Isolation voltage $BVs(\min)$ ($T_a = 25\text{°C}$)	2500 Vrms	3750 Vrms

Photo-IC Coupler for IPM Gate Drive: TLP106

The TLP106, housed in a 6-pin MFSOP, consists of a GaAlAs light emitting diode optically coupled to a high gain and fast speed photodetector.

The totem pole output structure makes bidirectional drive possible for the sink and source. This eliminates the need of a pull-up resistor. In addition, the shielded photodetector enables high common mode transient immunity, excellent input and output noise characteristics.

The TLP106 also guarantees the propagation delay time difference between on and off.

This photo-IC coupler is a buffer logic device; hence, this is suitable for use in a high active IPM gate drive.

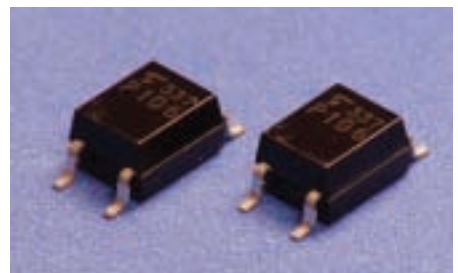

- Threshold input current: $I_{FLH} = 3$ mA (max)
- Propagation delay time: $t_{pLH}/t_{pHL} = 0.4$ μs (max)
- Propagation delay time difference between on and off: $|t_{pLH}-t_{pHL}| = 0.35$ μs (max)
- Common mode transient immunity: $CM_L/CM_H = 10$ kV/ μs (max)
- Supply voltage: 20 V (max)
- Isolation voltage: 3750 Vrms (min)

Truth Table

Input	LED	Tr1	Tr2	Output
H	ON	ON	OFF	H
L	OFF	OFF	ON	L

Pin Configuration

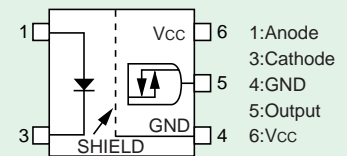

Circuit Configuration

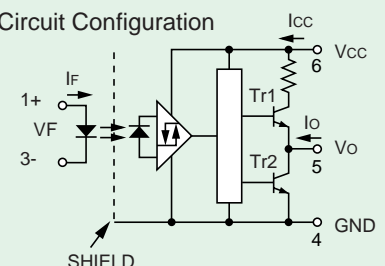

2 Photocoupler Product Tree

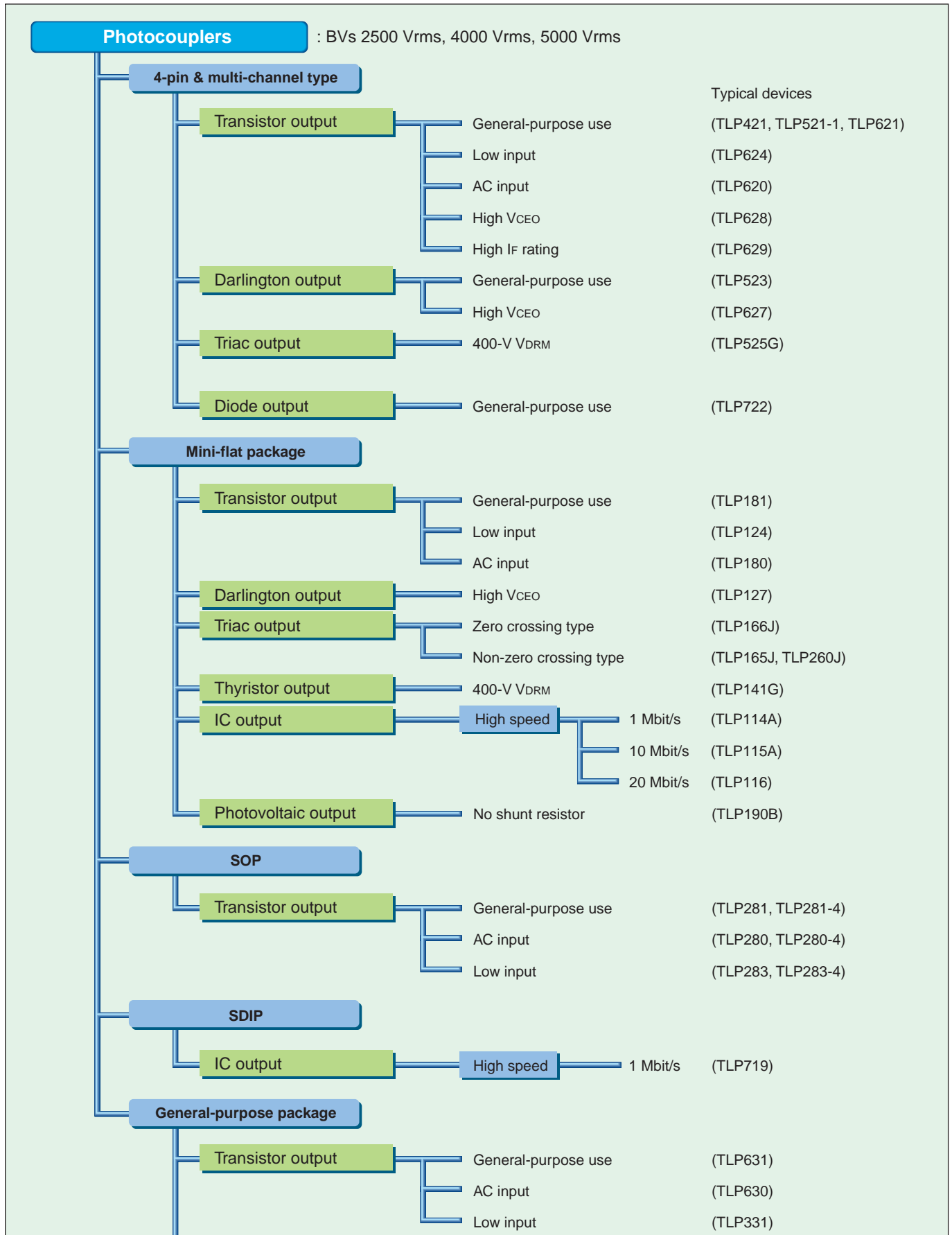

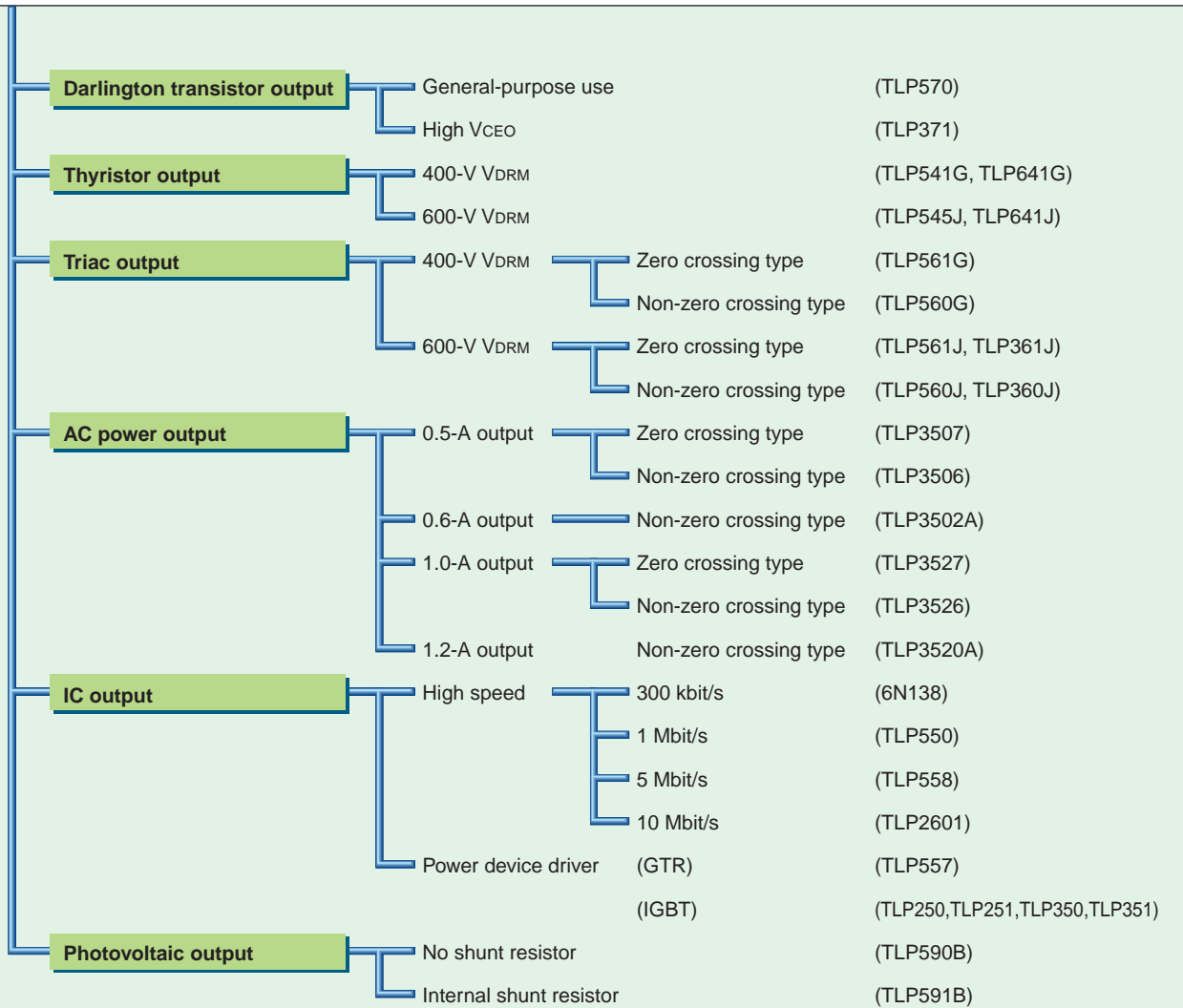



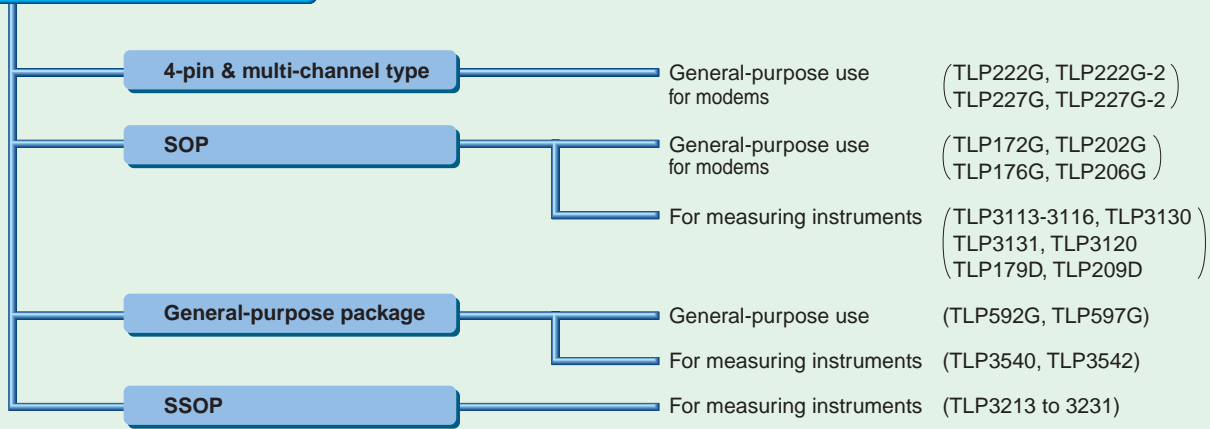



Photorelay (MOSFET output) : BVs 1500 Vrms, 2500 Vrms, 5000 Vrms



3 Recommended Products

Package		SSOP4	SOP4	SOP16	2.54SOP4	2.54SOP6	2.54SOP8
Appearance							
Page for package dimensions		p. 41	p. 40	p. 40	p. 40	p. 40	p. 40
Output type	Transistor		TLP280 TLP281 TLP283	TLP280-4 TLP281-4 TLP283-4			
	Darlington transistor						
	Diode						
	Thyristor						
	Triac						
	IC						
	Photorelay	TLP3213 TLP3214 TLP3215 TLP3216 TLP3217 TLP3230 TLP3231			TLP176A, TLP172A TLP176D, TLP172G TLP176G, TLP179D TLP3113 TLP3114 TLP3115 TLP3116 TLP3130 TLP3131	TLP197A TLP197G TLP192A TLP192G TLP199D	TLP200D TLP206A TLP206G TLP202A TLP202G TLP209D TLP3125
	Photovoltaic						
	AC power						

MFSOP6	SDIP	DIP4	DIP6	DIP8	DIP16	Page for product features
						–
p. 40	p. 39	p. 36	p. 36, 37	p. 38	p. 38	–
TLP180 TLP181 TLP124 TLP126 TLP130 TLP131 TLP137		TLP320 TLP321 TLP421 TLP521-1 TLP620 TLP621 TLP624 TLP626 TLP628 TLP629	TLP330 TLP331 TLP332 TLP531 TLP532 TLP630 TLP631 TLP632 TLP731 TLP732	TLP320-2 / 321-2 TLP521-2 / 620-2 TLP621-2 / 624-2 TLP626-2 / 628-2 TLP629-2	TLP320-4 / 321-4 TLP521-4 / 620-4 TLP621-4 / 624-4 TLP626-4 / 628-4 TLP629-4	p. 12 – 18
TLP127		TLP523 TLP627	TLP371 TLP372 TLP373 TLP570 TLP571 TLP572	TLP523-2 TLP627-2	TLP523-4 TLP627-4	p. 18, 19
		TLP722				p. 20
TLP141G			TLP541G TLP545J TLP641G / 641J TLP741G / 741J	TLP511GA TLP542G TLP543J TLP611J		p. 20
TLP160G / 160J TLP161G / 161J TLP165J / 166J TLP168J TLP260J (TLP261J)		TLP525G TLP360J TLP361J	TLP560G / 560J TLP561G / 561J TLP3022(S) / 3052(S) TLP3042(S) / 3062(S) TLP3063(S) TLP762J / 763J	TLP525G-2	TLP525G-4	p. 21 – 23
TLP112 / 112A TLP113 TLP114A TLP115 / 115A TLP116 (TLP106)	TLP719 (TLP701) (TLP716)		TLP512 TLP513	TLP250 TLP251 TLP351 (TLP350) TLP550 TLP557 TLP558 TLP559 TLP651 TLP750 TLP751 TLP759 TLP2200 TLP2530 TLP2531 TLP2601 TLP2630 TLP2631 6N136 6N137 6N139		p. 25 – 29
TLP3110 TLP3111		TLP224G TLP225A TLP227A TLP227G TLP227GA TLP222A TLP222G	TLP594G TLP592A / 597A TLP592G / 597G TLP597GA TLP797GA TLP797GAF TLP798G TLP3542	TLP224G-2 TLP227A-2 TLP227G-2 TLP227GA-2 TLP3540 TLP222A-2 TLP222G-2		p. 30 – 35
TLP190B TLP191B			TLP590B TLP591B			p. 29
				TLP3502 / 3502A TLP3503 TLP3506 / 3507 TLP3616 (/ TLP3617)	TLP3520 / 3520A TLP3521 TLP3526 / 3527 TLP3530	p. 24

4 Selection Guide

4.1 Transistor Output Devices

For Switching Supply, DC-DC Converter

Part Number	Pin Configuration	Features	CTR (%)				V _{CEO}	BV _s	Safety Standards ⁽²⁾					
			Rank	Min	Max	@I _F , V _{CE}			UL	TÜV	VDE	BSI	IEC	
TLP421 TLP421F		4-pin DIP High isolation voltage UL-recognized (double protection) VDE0884-approved with option (D4) SEMKO-approved	–	50	600	5 mA, 5 V	80 V	5000 Vrms	○	VDE 0884	△	○	EN 60065 EN 60950	△ 65 950 435 ⁽⁴⁾
			Y	50	150									
			GR	100	300									
			BL	200	600									
			GB	100	600									
			YH	75	150									
			GRL	100	200									
			GRH	150	300									
			BLL	200	400									
TLP181		Mini-flat MFSOP6 General-purpose High current transfer ratio SEMKO-approved	–	50	600	5 mA, 5 V	80 V	3750 Vrms	○	△	○ ⁽¹⁾	○	EN 60950	
			Y	50	150									
			GR	100	300									
			BL	200	600									
			GB	100	600									
			YH	75	150									
			GRL	100	200									
			GRH	150	300									
			BLL	200	400									
TLP281		SOP4 Half-pitch mini-flat Lead pitch = 1.27 mm General-purpose SEMKO-approved	–	50	600	5 mA, 5 V	80 V	2500 Vrms	○	△	○ ⁽¹⁾	○	EN 60950	
			Y	50	150									
			GR	100	300									
			BL	200	600									
			GB	100	600									
			YH	75	150									
			GRL	100	200									
			GRH	150	300									
			BLL	200	400									
TLP283		SOP4 Half-pitch mini-flat Lead pitch = 1.27 mm Low input current High speed	–	100	400	1 mA, 5 V	100 V	2500 Vrms	○					
			Y	50	150									
			GR	100	300									

For HA

Part Number	Pin Configuration	Features	CTR (%)				V _{CEO}	BV _s	Safety Standards ⁽²⁾					
			Rank	Min	Max	@I _F , V _{CE}			UL	TÜV	VDE	BSI	IEC	
TLP620 ⁽³⁾ TLP620F		4-pin DIP AC input VDE0884-approved with option (D4) SEMKO-approved	–	50	600	±5 mA, 5 V	55 V	5000 Vrms	○	VDE 0884	△	○	EN 60065 EN 60950	△ 65 950
			Y	50	150									
			GR	100	300									
			BL	200	600									
			GB	100	600									
TLP180 ⁽³⁾		Mini-flat MFSOP6 AC input SEMKO-approved	–	50	600	±5 mA, 5 V	80 V	3750 Vrms	○	○ ⁽¹⁾	△	○	EN 60950	
			Y	50	150									
			GR	100	300									
			BL	200	600									
			GB	100	600									
TLP280 ⁽³⁾		SOP4 Half-pitch mini-flat Lead pitch = 1.27 mm AC input SEMKO-approved	–	50	600	±5 mA, 5 V	80 V	2500 Vrms	○	△	○ ⁽¹⁾	○	EN 60950	
			Y	50	150									
			GR	100	300									
			BL	200	600									
			GB	100	600									

Note (1): VDE0884 safety standards for mini-flat photocoupler are different from those for standard DIP photocouplers because mini-flat package is compact and small. For details, please contact your nearest Toshiba sales office.

Note (2): In the safety standard column:

○: Approved ◎: SELV-approved △: Design which meets safety standard (as of November 2003) TÜV and VDE: VDE0884-approved with option D4 (It is changing into EN60747 from VDE0884.)

Note (3): The products with the ranks Y and BL are limited in production. For details, please contact your nearest Toshiba sales office.

Note (4): Only applied to the TLP421F

For PLC

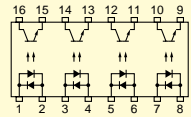
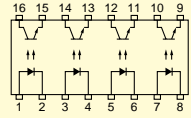
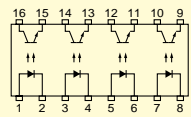
Part Number	Pin Configuration	Features	CTR (%)				V _{CEO}	BV _s	Safety Standards ⁽²⁾				
			Rank	Min	Max	@IF, V _{CE}			UL	TÜV	VDE	BSI	IEC
TLP280-4		SOP16 4 channels of the TLP280 Lead pitch = 1.27 mm AC input SEMKO-approved	-	50	600	±5 mA, 5 V	80 V	2500 Vrms	○	△	○ ⁽¹⁾	⊙	EN 60950
			GB	100									
TLP281-4		SOP16 4 channels of the TLP281 Lead pitch = 1.27 mm SEMKO-approved	-	50	600	5 mA, 5 V	80 V	2500 Vrms	○	△	○ ⁽¹⁾	⊙	EN 60950
			GB	100									
TLP283-4		SOP16 4 channels of the TLP283 Lead pitch = 1.27 mm Low input current High speed	-	100	400	1 mA, 5 V	100 V	2500 Vrms	○				

For Telecommunication

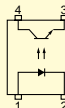
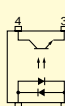
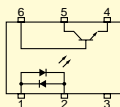
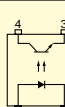
Part Number	Pin Configuration	Features	CTR (%)				V _{CEO}	BV _s	Safety Standards ⁽²⁾				
			Rank	Min	Max	@IF, V _{CE}			UL	TÜV	VDE	BSI	IEC
TLP629		4-pin DIP High input current 150 mA IF rating DC input	-	20	80	100 mA, 1 V	55 V	5000 Vrms	○	△ VDE 0884	△ 0884	△ EN 60065 EN 60950	
TLP320		4-pin DIP High input current AC input 150 mA IF rating	-	20	80	±100 mA, 1 V	55 V	5000 Vrms	○			⊙ EN 60950	
TLP330		6-pin DIP High input current AC input 150 mA IF rating	-	20	80	±100 mA, 1 V	55 V	5000 Vrms	○				
TLP628		4-pin DIP High V _{CEO} V _{CEO} = 350 V	-	50	600	5 mA, 5 V	350 V	5000 Vrms	○	△ VDE 0884	△ 0884	△ EN 60065 EN 60950	
			GB	100									

Note (1): VDE0884 standards for mini-flat photocoupler are different from those for standard DIP photocouplers because mini-flat package is compact and small. For details, please contact your nearest Toshiba sales office.

Note (2): In the safety standard column:

○: Approved ⊙: SELV-approved △: Design which meets safety standard (as of November 2003) TÜV and VDE: VDE0884-approved with option D4 (It is changing into EN60747 from VDE0884.

4 Selection Guide

Low Input Type

Part Number	Pin Configuration	Features	CTR (%)				V _{CEO}	BV _s	Safety Standards ⁽²⁾				
			Rank	Min	Max	@I _F , V _{CE}			UL	TÜV	VDE	BSI	IEC
TLP124		Mini-flat MFSOP6 Low input current	-	100	1200	1 mA, 0.5 V	80 V	3750 Vrms	○				
			BV	200									
TLP126		Mini-flat MFSOP6 AC input Low input current	-	100	1200	± 1 mA, 0.5 V			○				
TLP624		4-pin DIP Low input current BSI-approved	-	100	1200	1 mA, 0.5 V	55 V	5000 Vrms	○	△ VDE 0884	△ 0884	◎ EN 60065 EN 60950	△ 65 950
			BV	200									
TLP626		4-pin DIP Low input current AC input BSI-approved	-	100	1200	± 1 mA, 0.5 V	55 V	5000 Vrms	○	△ VDE 0884	△ 0884	◎ EN 60065 EN 60950	△ 65 950
			BV	200									
TLP137		Mini-flat MFSOP6 Low input current Internal base onnection	-	100	1200	1 mA, 0.5 V	80 V	3750 Vrms	○				
			BV	200									
TLP331		6-pin DIP Low input current Internal base onnection	-	100	1200	1 mA, 0.5 V	55 V	5000 Vrms	○				
			BV	200									
TLP332		6-pin DIP Low input current No internal base connection	-	100	1200	1 mA, 0.5 V	55 V	5000 Vrms	○				
			BV	200									

Note (2): In the safety standard column:

○: Approved ◎: SELV-approved △: Design which meets safety standard (as of November 2003) TÜV and VDE: VDE0884-approved with option D4 (It is changing into EN60747 from VDE0884.)

1-Channel Type (other than those above)

Part Number	Pin Configuration	Features	CTR (%)				V _{CEO}	BV _s	Safety Standards ⁽²⁾				
			Rank	Min	Max	@I _F , V _{CE}			UL	TÜV	VDE	BSI	IEC
TLP321		4-pin small package High V _{CEO}	—	50	600	5 mA, 5 V	80 V	5000 Vrms	○				
			Y	50	150								
			GR	100	300								
			BL	200	600								
			GB	100									
TLP521-1		4-pin DIP General-purpose	A	50	600	5 mA, 5 V	55 V	2500 Vrms	○				
			Y	50	150								
			GR	100	300								
			BL	200	600								
			GB	100									
			YH	75	150								
			GRL	100	200								
			GRH	150	300								
			BLL	200	400								
TLP621 TLP621F		4-pin DIP High isolation voltage UL-recognized (double protection) VDE0884-approved with option (D4) SEMKO-approved	—	50	600	5 mA, 5 V	55 V	5000 Vrms	○	△ VDE 0884	○ 0884	○ EN 60065 EN 60950	△ 65 950 435 ⁽⁴⁾
			GR	100	300								
			BL	200	600								
			GB	100									
			YH	75	150								
			GRL	100	200								
			GRH	150	300								
			BLL	200	400								
			TLP120 ⁽³⁾		Mini-flat MFSOP6 AC input								
Y	50	150											
GR	100	300											
BL	200	600											
GB	100												
TLP130 ⁽³⁾		Mini-flat MFSOP6 AC input Internal base connection	—	50	600	±5 mA, 5 V	80 V	3750 Vrms	○				
			Y	50	150								
			GR	100	300								
			BL	200	600								
GB	100												
TLP131 ⁽³⁾		Mini-flat MFSOP6 General-purpose Internal base connection	—	50	600	5 mA, 5 V	80 V	3750 Vrms	○				
			Y	50	150								
			GR	100	300								
			BL	200	600								
GB	100												
TLP630 ⁽³⁾		6-pin DIP AC input High isolation voltage	—	50	600	±5 mA, 5 V	55 V	5000 Vrms	○				
			Y	50	150								
			GR	100	300								
			BL	200	600								
GB	100												
TLP631 ⁽³⁾		6-pin DIP General-purpose Internal base connection	—	50	600	5 mA, 5 V	55 V	5000 Vrms	○				
			Y	50	150								
			GR	100	300								
			BL	200	600								
GB	100												
TLP632 ⁽³⁾		6-pin DIP General-purpose No internal base connection	—	50	600	5 mA, 5 V	55 V	5000 Vrms	○				
			Y	50	150								
			GR	100	300								
			BL	200	600								
GB	100												
TLP731 ⁽³⁾		6-pin DIP General-purpose No internal base connection	—	50	600	5 mA, 5 V	55 V	4000 Vrms	○	△ VDE 0884	○ 0884	○ EN 60065 EN 60950	△ 435 ⁽⁶⁾ 950
			Y	50	150								
			GR	100	300								
			BL	200	600								
GB	100												
TLP732 ⁽³⁾		6-pin DIP VDE0884-approved with option (D4) No internal base connection	—	50	600	5 mA, 5 V	55 V	4000 Vrms	○	△ VDE 0884	○ 0884	○ EN 60065 EN 60950	△ 435 ⁽⁶⁾ 950
			Y	50	150								
			GR	100	300								
			BL	200	600								
GB	100												

Note (2): In the safety standard column:

○: Approved ©: SELV-approved △: Design which meets safety standard (as of November 2003) TÜV and VDE: VDE0884-approved with option D4 (It is changing into EN60747 from VDE0884.)

Note (3): The products with the ranks Y and BL are limited in production. For details, please contact your nearest Toshiba sales office.

Note (4): Only applied to the TLP621F

Note (6): The IEC435 is approved after the leads of the devices are formed (LF2).

4 Selection Guide

1-Channel Type (other than those above) (continued)

Part Number	Pin Configuration	Features	CTR (%)				V _{CEO}	BV _s	Safety Standards ⁽²⁾				
			Rank	Min	Max	@I _F , V _{CE}			UL	TÜV	VDE	BSI	IEC
TLP733 ⁽³⁾ TLP733F ⁽³⁾		6-pin DIP VDE0884-approved with option (D4) SEMKO-approved	–	50	600	5 mA, 5 V	55 V	4000 Vrms	○	△ VDE 0884	○ 0884	○ EN 60065 EN 60950	△ 435 ⁽⁶⁾ 950
			Y	50	150								
			GR	100	300								
			BL	200	600								
TLP734 ⁽³⁾ TLP734F ⁽³⁾		6-pin DIP VDE0884-approved with option (D4) SEMKO-approved No internal base connection	–	50	600	5 mA, 5 V	55 V	4000 Vrms	○	△ VDE 0884	○ 0884	○ EN 60065 EN 60950	△ 435 ⁽⁴⁾ 950
			Y	50	150								
			GR	100	300								
			BL	200	600								
CNY17-2 CNY17-3 CNY17-4		Direct replacement for CNY17 Series	–	63	125	10 mA, 5 V	70 V	2500 Vrms	△				
				100	200								
				160	320								

2-Channel Type

Part Number	Pin Configuration	Features	CTR (%)				V _{CEO}	BV _s	Safety Standards ⁽²⁾				
			Rank	Min	Max	@I _F , V _{CE}			UL	TÜV	VDE	BSI	IEC
TLP504A		8-pin DIP General-purpose	–	50	600	5 mA, 5 V	55 V	2500 Vrms	○				
TLP321-2 ⁽⁵⁾		2 channels of the TLP321	–	50	600	5 mA, 5 V	80 V	5000 Vrms	○				
			GR	100	300								
			BL	200	600								
			GB	100	600								
TLP521-2 ⁽³⁾		8-pin DIP 2 channels of the TLP521-1	A	50	600	5 mA, 5 V	55 V	2500 Vrms	○				
			Y	50	150								
			GR	100	300								
			BL	200	600								
			GB	100	600								
TLP621-2 ⁽³⁾		8-pin DIP 2 channels of the TLP621 VDE0884-approved with option (D4) SEMKO-approved	–	50	600	5 mA, 5 V	55 V	5000 Vrms	○	△ VDE 0884	○ 0884	○ EN 60065 EN 60950	△ 65 950 435
			Y	50	150								
			GR	100	300								
			BL	200	600								
			GB	100	600								
TLP624-2		8-pin DIP 2 channels of the TLP624 BSI-approved	–	100	1200	1 mA, 0.5 V	55 V	5000 Vrms	○	△ VDE 0884	△ 0884	○ EN 60065 EN 60950	△ 65 950
			BV	200									
TLP628-2		8-pin DIP 2 channels of the TLP628	–	50	600	5 mA, 5 V	350 V	5000 Vrms	○	△ VDE 0884	△ 0884	△ EN 60065 EN 60950	
			GB	100									
TLP629-2		8-pin DIP 2 channels of the TLP629	–	20	80	100 mA, 1 V	55 V	5000 Vrms	○	△ VDE 0884	△ 0884	△ EN 60065 EN 60950	

Note (2): In the safety standard column:

○: Approved ○: SELV-approved △: Design which meets safety standard (as of November 2003) TÜV and VDE: VDE0884-approved with option D4 (It is changing into EN60747 from VDE0884.)

Note (3): The products with the ranks Y and BL are limited in production. For details, please contact your nearest Toshiba sales office.

Note (4): Only applied to the TLP734F

Note (5): The products with the ranks BL are limited in production. For details, please contact your nearest Toshiba sales office.

Note (6): Only applied to the TLP733F

2-Channel Type with AC Input

Part Number	Pin Configuration	Features	CTR (%)				V _{CEO}	BV _s	Safety Standards ⁽²⁾				
			Rank	Min	Max	@I _F , V _{CE}			UL	TÜV	VDE	BSI	IEC
TLP620-2		8-pin DIP 2 channels of the TLP620 VDE0884-approved with option (D4) SEMKO-approved	-	50	600	±5 mA, 5 V	55 V	5000 Vrms	○	△ VDE 0884	○ 0884	○ EN 60065 EN 60950	△ 65 950
			GB	100									
TLP626-2		8-pin DIP 2 channels of the TLP626 BSI-approved	-	100	1200	±1 mA, 0.5 V	55 V	5000 Vrms	○	△ VDE 0884	△ 0884	○ EN 60065 EN 60950	△ 65 950
			BV	200									
TLP320-2		8-pin DIP 2 channels of the TLP320	-	20	80	±100 mA, 1 V	55 V	5000 Vrms	○			○ EN 60950	

4-Channel Type

Part Number	Pin Configuration	Features	CTR (%)				V _{CEO}	BV _s	Safety Standards ⁽²⁾				
			Rank	Min	Max	@I _F , V _{CE}			UL	TÜV	VDE	BSI	IEC
TLP321-4		4 channels of the TLP321	-	50	600	5 mA, 5 V	80 V	5000 Vrms	○				
			GB	100									
TLP521-4		16-pin DIP 4 channels of the TLP521-1	A	50	600	5 mA, 5 V	55 V	2500 Vrms	○				
			GB	100									
TLP621-4		16-pin DIP 4 channels of the TLP621 VDE0884-approved with option (D4)	-	50	600	5 mA, 5 V	55 V	5000 Vrms	○	△ VDE 0884	○ 0884	○ EN 60065 EN 60950	△ 65 950 435
			GB	100									
TLP624-4		16-pin DIP 4 channels of the TLP624 BSI-approved	-	100	1200	1 mA, 0.5 V	55 V	5000 Vrms	○	△ VDE 0884	△ 0884	○ EN 60065 EN 60950	△ 65 950
			BV	200									
TLP628-4		16-pin DIP 4 channels of the TLP628	-	50	600	5 mA, 5 V	350 V	5000 Vrms	○	△ VDE 0884	△ 0884	△ EN 60065 EN 60950	
			GB	100									
TLP629-4		16-pin DIP 4 channels of the TLP629	-	20	80	100 mA, 1 V	55 V	5000 Vrms	○	△ VDE 0884	△ 0884	△ EN 60065 EN 60950	

Note (2): In the safety standard column:

○: Approved ◎: SELV-approved △: Design which meets safety standard (as of November 2003) TÜV and VDE: VDE0884-approved with option D4 (It is changing into EN60747 from VDE0884.)

4 Selection Guide

4-Channel Type with AC Input

Part Number	Pin Configuration	Features	CTR (%)				V _{CEO}	BV _s	Safety Standards ⁽²⁾				
			Rank	Min	Max	@I _F , V _{CE}			UL	TÜV	VDE	BSI	IEC
TLP620-4		16-pin DIP 4 channels of the TLP620 VDE0884-approved with option (D4)	-	50	600	±5 mA, 5 V	55 V	5000 Vrms	○	△ VDE 0884	○ 0884	○ EN 60065 EN 60950	△ 65 950
			GB	100									
TLP626-4		16-pin DIP 4 channels of the TLP626 BSI-approved	-	100	1200	±1 mA, 0.5 V	55 V	5000 Vrms	○	△ VDE 0884	△ 0884	○ EN 60065 EN 60950	△ 65 950
			BV	200									
TLP320-4		16-pin DIP 4 channels of the TLP320	-	20	80	±100 mA, 1 V	55 V	5000 Vrms	○			○ EN 60950	

JEDEC Type

Part Number	Pin Configuration	Features	CTR (%)				V _{CEO}	BV _s	Safety Standards ⁽²⁾				
			Rank	Min	Max	@I _F , V _{CE}			UL	TÜV	VDE	BSI	IEC
4N25(SHORT)		JEDEC type The 4N25 (short) can be used in place of products 4N25A to the 4N28.	-	20	-	10 mA, 10 V	30 V	2500 Vrms	○				
4N25A(SHORT)													
4N26(SHORT)													
4N27(SHORT)		JEDEC type The 4N35 (short) can be used in place of products the 4N36 and the 4N37.	-	100	-	80 V			○				
4N28(SHORT)													
4N35(SHORT)													
4N36(SHORT)		JEDEC type The 4N38 (short) can be used in place of the 4N38A (short).	-	10	-				○				
4N37(SHORT)													
4N38(SHORT)													
4N38A(SHORT)													

4.2 Darlington Transistor Output Devices

4-Pin Outline Type

Part Number	Pin Configuration	Features	CTR (%)		V _{CE(sat)} (V)		V _{CEO}	BV _s	Safety Standards ⁽²⁾				
			Min	@I _F , V _{CE}	Max	@I _C , V _F			UL	TÜV	VDE	BSI	IEC
TLP127		Mini-flat MFSOP6 High V _{CEO}	1000	1 mA, 1 V	1.2	100 mA, 10 mA	300 V	2500 Vrms	○	△ ⁽¹⁾	△	○ EN 60950	
TLP627		4-pin DIP High V _{CEO} BSI-approved SEMKO-approved	1000	1 mA, 1 V	1.2	100 mA, 10 mA	300 V	5000 Vrms	○	△ VDE 0884	○ 0884	○ EN 60065 EN 60950	△ 65 950
TLP627A		4-pin DIP High V _{CEO}	1500	1 mA, 1.2 V	1.2	100 mA, 10 mA	350 V	5000 Vrms	○	△	△	△	△
TLP523		4-pin DIP General-purpose	500	1 mA, 1 V	1	50 mA, 10 mA	55 V	2500 Vrms	○				

Note (1): VDE0884 standards for mini-flat photocoupler are different from those for standard DIP photocouplers because mini-flat package is compact and small. For details, please contact your nearest Toshiba sales office.

Note (2): In the safety standard column:

○: Approved ◎: SELV-approved △: Design which meets safety standard (as of November 2003) TÜV and VDE: VDE0884-approved with option D4 (It is changing into EN60747 from VDE0884.)

6-Pin Outline Type

Part Number	Pin Configuration	Features	CTR (%)		VCE(sat) (V)		VCEO	BVs	Safety Standards (2)				
			Min	@If, VCE	Max	@Ic, Vf			UL	TÜV	VDE	BSI	IEC
TLP371		6-pin DIP High V _{CEO}	1000	1 mA, 1 V	1.2	100 mA, 10 mA,	300 V	5000 Vrms	○				
TLP372		6-pin DIP High V _{CEO} No internal base connection											

2-Channel Type

Part Number	Pin Configuration	Features	CTR (%)		VCE(sat) (V)		VCEO	BVs	Safety Standards (2)				
			Min	@If, VCE	Max	@Ic, Vf			UL	TÜV	VDE	BSI	IEC
TLP523-2		8-pin DIP 2 channels of the TLP523	500	1 mA, 1 V	1	50 mA, 10 mA,	55 V	2500 Vrms	○				
TLP627-2		8-pin DIP 2 channels of the TLP627 BSI-approved SEMKO-approved	1000	1 mA, 1 V	1.2	100 mA, 10 mA,	300 V	5000 Vrms	○	△ VDE 0884	○ 0884	○ EN 60065 EN 60950	△ 65 950

4-Channel Type

Part Number	Pin Configuration	Features	CTR (%)		VCE(sat) (V)		VCEO	BVs	Safety Standards (2)				
			Min	@If, VCE	Max	@Ic, Vf			UL	TÜV	VDE	BSI	IEC
TLP523-4		16-pin DIP 4 channels of the TLP523	500	1 mA, 1 V	1.0	50 mA, 10 mA,	55 V	2500 Vrms	○				
TLP627-4		16-pin DIP 4 channels of the TLP627 BSI-approved	1000	1 mA, 1 V	1.2	100 mA, 10 mA,	300 V	5000 Vrms	○	△ VDE 0884	○ 0884	○ EN 60065 EN 60950	△ 65 950

JEDEC Type

Part Number	Pin Configuration	Features	CTR (%)		VCE(sat) (V)		VCEO	BVs	Safety Standards (2)				
			Min	@If, VCE	Max	@Ic, Vf			UL	TÜV	VDE	BSI	IEC
4N29(SHORT)		JEDEC type	100		1.0		30 V	2500 Vrms	○				
4N29A(SHORT)		The 4N29 (short) can be used in place of products the 4N29A to the 4N31.											
4N30(SHORT)			50	10 mA, 10 V	1.2	2 mA, 8 mA							
4N31(SHORT)													
4N32(SHORT)		JEDEC type	500		1.0								
4N32A(SHORT)		The 4N32 (short) can be used in place of products the 4N32A and the 4N33.											
4N33(SHORT)													

Note (1): VDE0884 standards for mini-flat photocoupler are different from those for standard DIP photocouplers because mini-flat package is compact and small. For details, please contact your nearest Toshiba sales office.

Note (2): In the safety standard column:

○: Approved ◎: SELV-approved △: Design which meets safety standard (as of November 2003) TÜV and VDE: VDE0884-approved with option D4 (It is changing into EN60747 from VDE0884.)

4 Selection Guide

4.3 Diode Output Devices

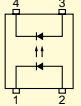
Part Number	Pin Configuration	Features	CTR (%)		V _{CE(sat)} (V)		V _{KAO}	BV _s	Safety Standards ⁽²⁾				
			Min	@I _F	Max	@V _{KA}			UL	TÜV	VDE	BSI	IEC
TLP722		4-pin DIP High-speed SEMKO-approved	0.1	10 mA	50 nA	10 V	30 V	4000 V _{rms}	○	○ VDE 0884	△ 0884	△ EN 60065 EN 60950	

4.4 Thyristor Output Devices

AC 100 to 120 V Line Type

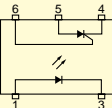
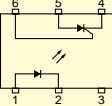
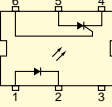
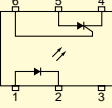
Part Number	Pin Configuration	Features	I _{FT}	V _{TM}		V _{DRM}	BV _s	Safety Standards ⁽²⁾				
			Max(mA)	Max(V)	@I _{TM}			UL	TÜV	VDE	BSI	IEC
TLP141G		Mini-flat MFSOP6 General-purpose	10	1.3	100 mA	400 V	2500 V _{rms}	○				
TLP541G		6-pin DIP General-purpose Low I _{FT}	7	1.3	100 mA	400 V	2500 V _{rms}	○				
TLP741G		6-pin DIP VDE0884-approved with option (D4)	10	1.3	100 mA	400 V	4000 V _{rms}	○	△ VDE 0884	○ 0884	○ EN 60065 EN 60950	△ 435 ⁽⁵⁾ 950
TLP747G TLP747GF		6-pin DIP VDE0884-approved with option (D4) Internal creepage: 4 mm (min) SEMKO-approved	15	1.3	100 mA	400 V	4000 V _{rms}	○	△ VDE 0884	○ 0884	○ EN 60065 EN 60950	△ 435 ⁽⁴⁾ 950

AC 200 to 240 V Line Type

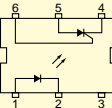
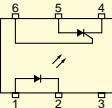
Part Number	Pin Configuration	Features	I _{FT}	V _{TM}		V _{DRM}	BV _s	Safety Standards ⁽²⁾				
			Max(mA)	Max(V)	@I _{TM}			UL	TÜV	VDE	BSI	IEC
TLP741J		6-pin DIP VDE0884-approved with option (D4)	10	1.3	100 mA	600 V	4000 V _{rms}	○	△ VDE 0884	○ 0884	○ EN 60065 EN 60950	△ 435 ⁽⁵⁾ 950
TLP747J TLP747JF		6-pin DIP VDE0884-approved with option (D4) Internal creepage: 4 mm (min) SEMKO-approved	15	1.3	100 mA	600 V	4000 V _{rms}	○	△ VDE 0884	○ 0884	○ EN 60065 EN 60950	△ 435 ⁽⁴⁾ 950

Note (2): In the safety standard column:

○: Approved ◎: SELV-approved △: Design which meets safety standard (as of November 2003) TÜV and VDE: VDE0884-approved with option D4 (It is changing into EN60747 from VDE0884.)

Note (4): Only applied to the TLP747GF/JF

Note (5): Only applied to the TLP741G (LF2)/J(LF2)

4.5 Triac Output Devices

For SSR

Part Number	Pin Configuration	Features	IFT		V _{TM}		ZC ⁽⁵⁾	V _{DRM}	BV _s	Safety Standards ⁽²⁾								
			Rank	Max(mA)	Max(V)	@ITM				UL	TÜV	VDE	BSI	IEC				
TLP260J		Mini-flat MFSOP6 Non-zero-voltage turn-on	—	10	2.8	70 mA	○	600 V	3000 Vrms	○	△ ⁽¹⁾	○						
TLP160G		Mini-flat MFSOP6 Non-zero-voltage turn-on	—	10						IFT7	7	400 V	2500 Vrms	○	△ ⁽¹⁾			
			IFT5	5														
TLP161G		Mini-flat MFSOP6 Zero-voltage turn-on	—	10						IFT7	7	400 V	2500 Vrms	○	△ ⁽¹⁾			
			IFT5	5														
TLP160J TLP165J ⁽¹⁾		Mini-flat MFSOP6 Non-zero-voltage turn-on	—	10						IFT7	7	600 V	2500 Vrms	○	△ ⁽¹⁾	○ ⁽⁴⁾		
			IFT5	5														
TLP161J TLP166J ⁽¹⁾		Mini-flat MFSOP6 Zero-voltage turn-on	—	10						IFT7	7	600 V	2500 Vrms	○	△ ⁽¹⁾	○ ⁽⁴⁾		
			IFT5	5														
TLP168J		Mini-flat MFSOP6 Zero-voltage turn-on Low IFT	—	3								○	600 V					

For OA

Part Number	Pin Configuration	Features	IFT		V _{TM}		ZC ⁽⁵⁾	V _{DRM}	BV _s	Safety Standards ⁽²⁾				
			Rank	Max(mA)	Max(V)	@ITM				UL	TÜV	VDE	BSI	IEC
** TLP360J ** TLP360JF		4-pin DIP Non-zero-voltage turn-on EN60747-approved with option (D4)	—	10	2.8	70 mA	○	600 V	5000 Vrms	○	⊙ EN60747	△		
			IFT7	7										
** TLP361J ** TLP361JF		4-pin DIP Zero-voltage turn-on EN60747-approved with option (D4)	—	10	2.8	70 mA	○	600 V	5000 Vrms	○	⊙ EN60747	△		
			IFT7	7										

** : Under development

Note (1): VDE0884 standards for mini-flat photocoupler are different from those for standard DIP photocouplers because mini-flat package is compact and small.
For details, please contact your nearest Toshiba sales office.

Note (2): In the safety standard column:

○: Approved ⊙: SELV-approved △: Design which meets safety standard (as of November 2003) TÜV and VDE: VDE0884-approved with option D4
(It is changing into EN60747 from VDE0884.)

Note (4): Only applied to the TLP165J/166J

Note (5): Zero Cross circuit

4 Selection Guide

AC 100 to 120 V Line Type

Part Number	Pin Configuration	Features	IFT		V _{TM}		V _{DRM}	BV _s	Safety Standards ⁽²⁾					
			Rank	Max(mA)	Max(V)	@ I _{TM}			ZC ⁽⁵⁾	UL	TÜV	VDE	BSI	IEC
TLP525G		4-pin DIP	—	10	3	100 mA		400 V	2500 V _{rms}	○				
TLP560G		6-pin DIP General-purpose Non-zero-voltage turn-on	—	10	3	100 mA		400 V	2500 V _{rms}	○				
			IFT7	7										
			IFT5	5										
TLP561G		6-pin DIP General-purpose Zero-voltage turn-on	—	10	3	100 mA	○	400 V	2500 V _{rms}	○				
			IFT7	7										
			IFT5	5										
TLP3022(S) TLP3022F(S)		6-pin DIP Direct replacement for XXX3020/3021/3022 VDE0884-approved SEMKO-approved	—	10	3	100 mA		400 V	5000 V _{rms}	○	△ VDE 0884	◎ 0884	◎ EN 60065 EN 60950	△ 950
			TLP3023(S) TLP3023F(S)	6-pin DIP Direct replacement for XXX3023 VDE0884-approved SEMKO-approved										
TLP3042(S) TLP3042F(S)		6-pin DIP Direct replacement for XXX3040/3041/3042 VDE0884-approved SEMKO-approved	—	10	3	100 mA	○	400 V	5000 V _{rms}	○	△ VDE 0884	◎ 0884	◎ EN 60065 EN 60950	△ 950
			TLP3043(S) TLP3043F(S)	6-pin DIP Direct replacement for XXX3043 VDE0884-approved SEMKO-approved										

Note (2): In the safety standard column:

○: Approved ◎: SELV-approved △: Design which meets safety standard (as of November 2003) TÜV and VDE: VDE0884-approved with option D4 (It is changing into EN60747 from VDE0884.)

Note (5): Zero Cross circuit

AC 200 to 240 V Line Type

Part Number	Pin Configuration	Features	IFT		V _{TM}		ZC ⁽⁵⁾	V _{DRM}	BV _s	Safety Standards ⁽²⁾				
			Rank	Max(mA)	Max(V)	@ I _{TM}				UL	TÜV	VDE	BSI	IEC
TLP560J		6-pin DIP General-purpose Non-zero-voltage turn-on	—	10	3	100 mA		600 V	2500 V _{rms}	○				
			IFT7	7										
TLP561J		6-pin DIP General-purpose Zero-voltage turn-on Includes a Z.C. circuit.	—	10	3	100 mA	○	600 V	2500 V _{rms}	○				
			IFT7	7										
TLP762J TLP762JF		6-pin DIP Internal creepage: 4 mm (min) VDE0884-approved with option (D4) SEMKO-approved Non-zero-voltage turn-on	—	10	3	100 mA		600 V	4000 V _{rms}	○	△ VDE 0884	○ 0884	○ EN 60065 EN 60950	△ 435 ⁽⁴⁾ 950
TLP763J TLP763JF		6-pin DIP Internal creepage: 4 mm (min) VDE0884-approved with option (D4) SEMKO-approved Zero-voltage turn-on Includes a Z.C. circuit.	—	10	3	100 mA	○	600 V	4000 V _{rms}	○	△ VDE 0884	○ 0884	○ EN 60065 EN 60950	△ 435 ⁽⁴⁾ 950
TLP3052(S) TLP3052F(S)		6-pin DIP Direct replacement for XXX3052 VDE0884-approved SEMKO-approved	—	10	3	100 mA		600 V	5000 V _{rms}	○	△ VDE 0884	○ 0884	○ EN 60065 EN 60950	△ 950
TLP3062(S) TLP3062F(S)		6-pin DIP Direct replacement for XXX3060/3061/3062 VDE0884-approved SEMKO-approved	—	10	3	100 mA	○	600 V	5000 V _{rms}	○	△ VDE 0884	○ 0884	○ EN 60065 EN 60950	△ 950
TLP3063(S) TLP3063F(S)		6-pin DIP Direct replacement for XXX3063 VDE0884-approved SEMKO-approved	—	5										
TLP3064(S) TLP3064F(S)		6-pin DIP Extra-low I _{FT} VDE0884-approved SEMKO-approved	—	3										

Multi-channel Type

Part Number	Pin Configuration	Features	IFT		V _{TM}		ZC ⁽⁵⁾	V _{DRM}	BV _s	Safety Standards ⁽²⁾				
			Rank	Max(mA)	Max(V)	@ I _{TM}				UL	TÜV	VDE	BSI	IEC
TLP525G-2		8-pin DIP 2 channels of the TLP525G	—	10	3	100 mA		400 V	2500 V _{rms}	○				
TLP525G-4		16-pin DIP 4 channels of the TLP525G	—	10										

Note (2): In the safety standard column:

○: Approved ◎: SELV-approved △: Design which meets safety standard (as of November 2003) TÜV and VDE: VDE0884-approved with option D4 (It is changing into EN60747 from VDE0884.)

Note (4): Only applied to the TLP762JF/763JF

Note (5): Zero Cross circuit

4 Selection Guide

4.6 AC Power (Triac Output Devices)

AC 100 to 120 V Line Type

Part Number	Pin Configuration	Features	IFT		V _{TM}	ZC ⁽⁵⁾	V _{DRM}	BVs	Safety Standards ⁽²⁾					
			Rank	Max(mA)	@Ta=40°C				UL	TÜV	VDE	BSI	IEC	
TLP3502		8-pin DIP Direct control up to 0.5 Arms load Non-zero-voltage turn-on	—	10	0.5 Arms		400 V	2500 Vrms	○					
			IFT7	7										
			IFT5	5										
TLP3502A		8-pin DIP Direct control up to 0.6 Arms load Non-zero-voltage turn-on	—	10	0.6 Arms		400 V	2500 Vrms	○					
			IFT7	7										
			IFT5	5										
TLP3503		8-pin DIP Direct control up to 0.5 Arms load Zero-voltage turn-on Includes a Z.C.circuit.	—	10	0.5 Arms	○	400 V	2500 Vrms	○					
			IFT7	7										
			IFT5	5										
TLP3520		16-pin DIP Direct control up to 1.0 Arms load Non-zero-voltage turn-on	—	10	1 Arms		400 V	2500 Vrms	○					
			IFT7	7										
			IFT5	5										
TLP3520A		16-pin DIP Direct control up to 1.2 Arms load Non-zero-voltage turn-on	—	10	1.2 Arms		400 V	2500 Vrms	○					
			IFT7	7										
			IFT5	5										
TLP3521		16-pin DIP Direct control up to 1.0 Arms load Zero-voltage turn-on Includes a Z.C.circuit.	—	10	1 Arms	○	400 V	2500 Vrms	○					
			IFT7	7										
			IFT5	5										
TLP3530		16-pin DIP 2-Channel type Direct control up to 1.0 Arms load (for 1 ch) / 1.4 Arms load (for 2 ch) Non-zero-voltage turn-on	—	10	1 Arms [for 1 channel]		400 V	2500 Vrms	○					
			IFT7	7	1.4 Arms [for 2 channels]									

AC 200 to 240 V Line Type

Part Number	Pin Configuration	Features	IFT		V _{TM}	ZC ⁽⁵⁾	V _{DRM}	BVs	Safety Standards ⁽²⁾					
			Rank	Max(mA)	@Ta=40°C				UL	TÜV	VDE	BSI	IEC	
TLP3506 TLP3507		8-pin DIP Direct control up to 0.5 Arms load High V _{DRM} Zero-voltage turn-on (TLP3507) The TLP3507 includes a Z.C.circuit.	—	10	0.5 Arms		600 V	2500 Vrms	○					
TLP3526 TLP3527		16-pin DIP Direct control up to 1.0 Arms load High V _{DRM} Zero-voltage turn-on (TLP3527) The TLP3527 includes a Z.C.circuit.	—	10	1 Arms		600 V		○	⊙ 0884	△			
** TLP3616 ** TLP3617		8-pin DIP Direct control up to 1.0 Arms load High V _{DRM} Zero-voltage turn-on (TLP3617) The TLP3617 includes a Z.C.circuit.	—	10	1 Arms		600 V		△					

** : Under development

Note (2): In the safety standard column:

○ : Approved ⊙ : SELV-approved △ : Design which meets safety standard (as of November 2003) TÜV and VDE: VDE0884-approved with option D4 (It is changing into EN60747 from VDE0884.)

Note (5): Zero Cross circuit

4.7 IC Output Devices

For Plasma Display Panel, FA

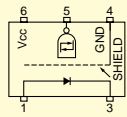
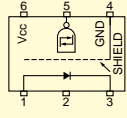
Part Number	Pin Configuration	Features	Data Rate (NRZ) Typ.	CTR	@IF	BVs	Safety Standards ⁽²⁾				
							UL	TÜV	VDE	BSI	IEC
** TLP116		Mini-flat MFSOP6 High speed High CMR Low power dissipation	35 ns	Totem pole output (Inverter logic)	5 mA	3750 Vrms	○				
** TLP716 ** TLP716F		6-pin SDIP High speed High CMR Internal shield Low power dissipation	45 ns	Totem pole output (Inverter logic)	5 mA	5000 Vrms	○	△	△		

For IPM Driver

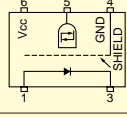
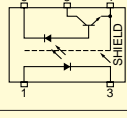
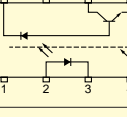
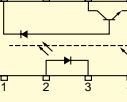
Part Number	Pin Configuration	Features	Data Rate (NRZ) Typ.	CTR	@IF	BVs	Safety Standards ⁽²⁾				
							UL	TÜV	VDE	BSI	IEC
** TLP106		Mini-flat MFSOP6 IPM direct drive High CMR	250 ns	Totem pole output (Buffer logic type)	3 mA	3750 Vrms	△				
TLP114A(IGM)		Mini-flat MFSOP6 High CMR	0.45 µs	25% Min	10 mA	3750 Vrms	○	○ ⁽¹⁾	△		
TLP559(IGM)		8-pin DIP High CMR Internal shield	0.45 µs	25% Min	10 mA	2500 Vrms	○				
TLP759(IGM) TLP759F(IGM)		8-pin DIP Internal shield VDE0884-approved with option (D4) SEMKO-approved	0.45 µs	25% Min	10 mA	5000 Vrms	○	△ VDE 0884	◎ 0884	◎ EN 60065 EN 60950	△ 65 950

** : Under development

Note (1): VDE0884 standards for mini-flat photocoupler are different from those for standard DIP photocouplers because mini-flat package is compact and small. For details, please contact your nearest Toshiba sales office.

Note (2): In the safety standard column:

○: Approved ◎: SELV-approved △: Design which meets safety standard (as of November 2003) TÜV and VDE: VDE0884-approved with option D4 (It is changing into EN60747 from VDE0884.)

4 Selection Guide

For IGBT/MOSFET/Giant Transistor Drivers

Part Number	Pin Configuration	Features	Data Rate (NRZ) Typ.	CTR	@IF	BVs	Safety Standards ⁽²⁾				
							UL	TÜV	VDE	BSI	IEC
TLP557		8-pin DIP Giant transistor direct drive	1 μ s	0.25 A constant current output	5 mA	2500 Vrms	○				
TLP251 TLP251F		8-pin DIP Low-power IGBT/MOSFET direct drive VDE0884-approved with option (D4)	0.25 μ s	\pm 0.4 A peak output current (max)	5 mA	2500 Vrms	○	△ VDE 0884	◎ 0884		
TLP351 TLP351F		8-pin DIP Medium-power IGBT/MOSFET direct drive High speed Low power dissipation	0.2 μ s	\pm 0.6 A peak output current (max)	5 mA	3750 Vrms	○	◎ VDE 0884	△ 0884		
** TLP701 ** TLP701F		6-pin SDIP IGBT/MOSFET direct drive High speed Low power dissipation	0.25 μ s	\pm 0.6 A peak output current (max)	5 mA	5000 Vrms	○	△	△		
TLP250 TLP250F		8-pin DIP Medium-power IGBT/MOSFET direct drive High speed VDE0884-approved with option (D4)	0.15 μ s	\pm 1.5 A peak output current (max)	5 mA	2500 Vrms	○	△ VDE 0884	◎ 0884		
TLP250(INV) TLP250F(INV)		8-pin DIP Medium-power IGBT/MOSFET direct drive High speed For inverters	0.15 μ s	\pm 2.0 A peak output current (max)	5 mA		○	△ VDE 0884	◎ 0884		
** TLP350 ** TLP350F		8-pin DIP Medium-power IGBT/MOSFET direct drive High CMR High speed Low power dissipation	0.25 μ s	\pm 2.0 A peak output current (max)	5 mA	3750 Vrms	○	△	△		

** : Under development

Note (2): In the safety standard column:

○: Approved ◎: SELV-approved △: Design which meets safety standard (as of November 2003) TÜV and VDE: VDE0884-approved with option D4 (It is changing into EN60747 from VDE0884.)

1-Channel Type (other than those above)

Part Number	Pin Configuration	Features	Data Rate (NRZ) Typ.	CTR	@IF	BVs	Safety Standards ⁽²⁾				
							UL	TÜV	VDE	BSI	IEC
TLP112		Mini-flat MFSOP6 High speed	1 Mbit/s	10% Min	16 mA	2500 Vrms	○				
TLP112A		Mini-flat MFSOP6 High CTR		20% Min							
TLP114A		Mini-flat MFSOP6 High CMR	1 Mbit/s	20% Min	16 mA	3750 Vrms	○	○ ⁽¹⁾	△		
TLP550		8-pin DIP No internal base connection Standard	1 Mbit/s	10% Min (19% min for rank O)	16 mA	2500 Vrms	○				
TLP559		8-pin DIP High CMR Internal shield	1 Mbit/s	20% Min	16 mA	2500 Vrms	○				
TLP651		8-pin DIP High isolation voltage Internal base connection	1 Mbit/s	10% Min (19% min for rank O)	16 mA	5000 Vrms	○				
TLP750		8-pin DIP High isolation voltage VDE0884-approved with option (D4) SEMKO-approved	1 Mbit/s	10% Min (19% min for rank O)	16 mA		○	△ VDE 0884	◎ 0884	◎ EN 60065 EN 60950	△ 65 950
TLP751		8-pin DIP High isolation voltage Internal base connection VDE0884-approved with option (D4) SEMKO-approved	1 Mbit/s	10% Min	16 mA		○	△ VDE 0884	◎ 0884	◎ EN 60065 EN 60950	△ 65 950
TLP759 TLP759F		8-pin DIP Internal shield VDE0884-approved with option (D4) SEMKO-approved	1 Mbit/s	20% Min	16 mA		○	△ VDE 0884	◎ 0884	◎ EN 60065 EN 60950	△ 65 950
** TLP719 ** TLP719F		6-pin SDIP High CMR Internal shield	1 Mbit/s	20% Min	16 mA	5000 Vrms	○	△	△		

** : Under development

Note (1): VDE0884 standards for mini-flat photocoupler are different from those for standard DIP photocouplers because mini-flat package is compact and small. For details, please contact your nearest Toshiba sales office.

Note (2): In the safety standard column:

○: Approved ◎: SELV-approved △: Design which meets safety standard (as of November 2003) TÜV and VDE: VDE0884-approved with option D4 (It is changing into EN60747 from VDE0884.)

4 Selection Guide

1-Channel Type (other than those above) (continued)

Part Number	Pin Configuration	Features	Data Rate (NRZ) Typ.	CTR	@IF	BVs	Safety Standards ⁽²⁾				
							UL	TÜV	VDE	BSI	IEC
TLP558		8-pin DIP 3 state output Low input Inverter logic	5 Mbit/s	3-state output	1.6 mA	2500 Vrms	○				
TLP2200		8-pin DIP 3 state output Low input current Buffer logic	5 Mbit/s	3-state output	1.6 mA	2500 Vrms	○				
TLP113		Mini-flat MFSOP6 High speed	10 Mbit/s	Open-collector	10 mA	2500 Vrms	○				
TLP115		Mini-flat MFSOP6 High CMR	10 Mbit/s	Open-collector	10 mA	2500 Vrms	○				
TLP115A		Mini-flat MFSOP6 High CMR Low input current			5 mA						
TLP2601		8-pin DIP High CMR High speed	10 Mbit/s	Open-collector	5 mA	2500 Vrms	○				

2-Channel Type

Part Number	Pin Configuration	Features	Data Rate (NRZ) Typ.	CTR	@IF	BVs	Safety Standards ⁽²⁾				
							UL	TÜV	VDE	BSI	IEC
TLP2530		2 channels of the 6N135	1 Mbit/s	7% Min	16 mA	2500 Vrms	○				
TLP2531		2 channels of the 6N136	1 Mbit/s	19% Min	16 mA		○				
TLP2630		2 channels of the 6N137	10 Mbit/s	Open-collector	5 mA		○				
TLP2631		High CMR Two channels of the TLP2601	10 Mbit/s	Open-collector	5 mA		○				

Note (2): In the safety standard column:

○: Approved ◎: SELV-approved △: Design which meets safety standard (as of November 2003) TÜV and VDE: VDE0884-approved with option D4 (It is changing into EN60747 from VDE0884.)

JEDEC Type

Part Number	Pin Configuration	Features	Data Rate (NRZ) Typ.	CTR		BVs	Safety Standards ⁽²⁾					
					@I _F		UL	TÜV	VDE	BSI	IEC	
6N135		JEDEC type Standard	1 Mbit/s	7% Min	16 mA	2500 Vrms	○					
6N136				19% Min								
6N137		JEDEC type High speed	10 Mbit/s	700% Typ.	5 mA		○					
6N138		JEDEC type High CTR	300 kbit/s	300% Min	1.6 mA		○					
6N139				400% Min	0.5 mA							

4.8 Photovoltaic Output Devices

Part Number	Pin Configuration	Features	Short-Circuit Current (µA)			Open Voltage Voc (V)		BVs	Safety Standards ⁽²⁾				
			Rank	Min	@I _F	Min	@I _F		UL	TÜV	VDE	BSI	IEC
TLP190B		Mini-flat MFSOP6	—	12	10 mA	7	10 mA	2500 Vrms	○				
TLP191B		Mini-flat MFSOP6 Internal shunt resistor	—	24	20 mA	7	20 mA						
TLP590B		6-pin DIP General-purpose	—	12	10 mA	7	10 mA						
			C20	20									
TLP591B		6-pin DIP Internal shunt resistor	—	24	20 mA	7	20 mA	○					
			C40	40									

Note (2): In the safety standard column:

○: Approved ○: SELV-approved △: Design which meets safety standard (as of November 2003) TÜV and VDE: VDE0884-approved with option D4 (It is changing into EN60747 from VDE0884.)

4 Selection Guide

4.9 Photo Relays

MOSFET Output Devices, 1-Form-A

Part Number	Pin Configuration	Features	V _{OFF} Min (V)	I _{ON} Max (A)	R _{ON} Max (Ω)	R _{ON} Typ. (Ω)	Coff Typ. (pF)	I _{FT} Max (mA)	BV _S Min (V _{rms})	Safety Standards ⁽²⁾							
										UL	TÜV	VDE	BSI	IEC			
TLP3130		2.54SOP4 Lower CR For testers	20	0.16	8	5	1	4	1500	○							
TLP3230		SSOP4 Lower CR For testers		0.16	8	5	1	4		△							
TLP3131		2.54SOP4 Lower CR For testers		0.3	1.5	1	5	4		○							
TLP3231		SSOP4 Lower CR For testers		0.45	1.2	0.8	5	4		△							
TLP3113		2.54SOP4 Lower CR For testers	40	0.08	35	25	0.6	4	1500	○							
TLP3213		SSOP4 Lower CR For testers		0.08	35	25	0.6	4		△							
TLP3116		2.54SOP4 Lower CR For testers		0.12	15	10	1	4		○							
TLP3216		SSOP4 Lower CR For testers		0.12	15	10	1	4		△							
TLP3114		2.54SOP4 Lower CR For testers		0.25	3	2	5	4		○							
TLP3214		SSOP4 Lower CR For testers		0.25	3	2	5	4		△							
TLP3115		2.54SOP4 Lower CR For testers		0.3	1.5	1	10	4		○							
TLP3215		SSOP4 Lower CR For testers		0.3	1.5	1	10	4		△							
TLP3110				MFSOP6 (4-pin) Lower CR For testers	60	0.35	1.2	0.9		100	4	1500	○				
TLP172A				2.54 SOP4 Economical High output current		0.4	2	1		130	3		○				
TLP176A		2.54 SOP4 High output current	0.4	2		1	130	3	○	△	○						
TLP192A		2.54 SOP6 Economical High output current	0.4	2		1	130	3	○								
TLP197A		2.54 SOP6 High output current	0.4	2		1	130	3	○								
TLP225A		4-pin DIP For DC use only	0.5	1.1		0.8	-	5	○								
TLP222A		4-pin DIP Economical High output current	0.5	2		1	130	3	○								
TLP227A		4-pin DIP High output current	0.5	2		1	130	3	○					○			

Note (2): In the safety standard column:

○: Approved ○: SELV-approved △: Design which meets safety standard (as of November 2003) TÜV and VDE: VDE0884-approved with option D4 (It is changing into EN60747 from VDE0884.)

MOSFET Output Devices, 1-Form-A (continued)

Part Number	Pin Configuration	Features	V _{OFF} Min (V)	I _{ON} Max (A)	R _{ON} Max (Ω)	R _{ON} Typ. (Ω)	Coff Typ. (pF)	I _{FT} Max (mA)	BV _s Min (V _{rms})	Safety Standards ⁽²⁾				
										UL	TÜV	VDE	BSI	IEC
TLP592A		6-pin DIP Economical High output current	60	0.5	2	1	130	3	2500	○				
TLP597A		6-pin DIP High output current		0.5	2	1	130	3		○				
TLP3540		8-pin DIP High output current		2	0.12	—	600	5	1500	○				
TLP3542		6-pin DIP High output current	2.5	0.1	0.065	400	3	2500	△					
TLP3111		MFSOP6 (4-pin) Lower CR For testers	80	0.1	20	16	11	4	1500	○				
TLP3217		SSOP4 For testers		0.12	12	8	5	5		△				
TLP3121		2.54SOP4 Lower CR For testers		0.35	1.2	1	30	4		○				
TLP3120		2.54SOP6 High output current		1.25	0.15	0.11	460	5		○				
TLP179D		2.54SOP4 Lower CR For testers	200	0.05	50	40	15	3	1500	○				
TLP199D		2.54SOP6 Lower CR For testers		0.05	50	40	15	3		○				
TLP176D		2.54SOP4 For PBXes, telecom		0.2	8	5	100	3		○	△	○		
TLP197D		2.54SOP6 General-purpose		0.2	8	5	100	3		○				
TLP172G		2.54SOP4 Economical General-purpose		0.11	35	25	30	3		○				
TLP192G		2.54SOP6 Economical General-purpose	350	0.11	35	25	30	3	1500	○				
TLP176G		2.54SOP4 General-purpose		0.12	35	15	40	3		○	△	○	○	○

Note (2): In the safety standard column:

○: Approved ○: SELV-approved △: Design which meets safety standard (as of November 2003) TÜV and VDE: VDE0884-approved with option D4 (It is changing into EN60747 from VDE0884.)

4 Selection Guide

MOSFET Output Devices, 1-Form-A (continued)

Part Number	Pin Configuration	Features	V _{OFF} Min (V)	I _{ON} Max (A)	R _{ON} Max (Ω)	R _{ON} Typ. (Ω)	C _{off} Typ. (pF)	I _{FT} Max (mA)	BVs Min (V _{rms})	Safety Standards ⁽²⁾							
										UL	TÜV	VDE	BSI	IEC			
TLP197G		2.54SOP6 General-purpose	350	0.12	35	15	40	3	1500	○	△	○	○	○			
TLP174G		2.54SOP4 Current-limiting function General-purpose, For modems		0.12	35	15	40	3		○					○		
TLP222G		4-pin DIP Economical General-purpose, For modems		0.12	35	25	30	3	2500	○				○	○		
TLP227G		4-pin DIP General-purpose, For modems		0.12	35	15	40	3		○	△	○	○	○			
TLP592G		6-pin DIP Economical General-purpose		0.12	35	25	30	3		○							
TLP597G		6-pin DIP General-purpose		0.12	35	15	40	3		○	△	○	○	○			
TLP224G		4-pin DIP Current-limiting function For modems		0.12	35	15	40	3		○				△	○		
TLP594G		6-pin DIP Current-limiting function General-purpose		0.12	35	15	40	3		○							
TLP176GA		2.54SOP4 General-purpose, For modems		400	0.12	35	17	70	3	1500	○				○		
TLP174GA		2.54SOP4 Current-limiting function General-purpose, For modems			0.12	35	17	70	3		○						
TLP197GA		2.54SOP6 Current-limiting function General-purpose	0.12		35	17	70	3	2500	○				○			
TLP3125		2.54SOP8	0.2		4	3.5	410	3		○							
TLP227GA		4-pin DIP General-purpose, For modems	0.12		35	17	70	3		○						○	
TLP224GA		4-pin DIP Current-limiting function For modems	0.12		35	17	70	3		○						○	
TLP597GA		6-pin DIP, General-purpose	400		0.12	35	17	70		3	2500	○					○
TLP797GA		6-pin DIP High isolation voltage			0.12	35	17	70		3	5000	○	△	△	△	△	△
TLP797J		6-pin DIP High isolation voltage			600	0.1	35	25	120	3		○	△	△	△	△	△

Note (2): In the safety standard column:

○: Approved ◎: SELV-approved △: Design which meets safety standard (as of November 2003) TÜV and VDE: VDE0884-approved with option D4 (It is changing into EN60747 from VDE0884.)

MOSFET Output Devices, 2-Form-A

Part Number	Pin Configuration	Features	V _{OFF} Min (V)	I _{ON} Max (A)	R _{ON} Max (Ω)	R _{ON} Typ. (Ω)	Coff Typ. (pF)	I _{FT} Max (mA)	BV _s Min (V _{rms})	Safety Standards (2)					
										UL	TÜV	VDE	BSI	IEC	
TLP202A		2.54SOP8, 2 channels of the TLP172A	60	0.4	2	1	130	3	1500	○					
TLP206A		2.54SOP8, 2 channels of the TLP176A		0.4	2	1	130	3		○					
TLP222A-2		8-pin DIP 2 channels of the TLP222A		2500	0.5	2	1	130	3	○					
TLP227A-2		8-pin DIP 2 channels of the TLP227A			0.5	2	1	130	3	○				○	
TLP209D		2.54SOP8, 2 channels of the TLP179D		200	0.05	50	40	15	3	1500	○				
TLP200D		2.54SOP8, 2 channels of the TLP176D			0.2	8	5	100	3		○				
TLP202G		2.54SOP8, 2 channels of the TLP172G	350	0.11	35	25	30	3	○						
TLP206G		2.54SOP8, 2 channels of the TLP176G		0.12	35	17	40	3	○		△	○	○	○	
TLP204G		2.54SOP8, 2 channels of the TLP174G		0.12	35	17	40	3	○					○	
TLP222G-2		8-pin DIP, 2 channels of the TLP222G		0.12	50	25	30	3	○					○	○
TLP227G-2	8-pin DIP, 2 channels of the TLP227G	2500	0.12	35	15	40	3	○	△	○	○	○			
TLP224G-2	8-pin DIP, 2 channels of the TLP224G		0.12	35	15	40	3	○				○	○		
TLP206GA		2.54SOP8, 2 channels of the TLP176GA	400	0.12	35	17	70	3	1500	○			○		
TLP204GA		2.54SOP8, 2 channels of the TLP174GA		0.12	35	17	70	3		○					
TLP227GA-2	8-pin DIP, 2 channels of the TLP227GA	2500		0.12	35	17	70	3	○				○		
TLP224GA-2	8-pin DIP, 2 channels of the TLP224GA			0.12	35	17	70	3	○				○		

Note (2): In the safety standard column:

○: Approved ◎: SELV-approved △: Design which meets safety standard (as of November 2003) TÜV and VDE: VDE0884-approved with option D4 (It is changing into EN60747 from VDE0884.)

4 Selection Guide

MOSFET Output Devices, 1-Form-B

Part Number	Pin Configuration	Features	V _{OFF} Min (V)	I _{ON} Max (A)	R _{ON} Max (Ω)	R _{ON} Typ. (Ω)	Coff Typ. (pF)	I _{FT} Max (mA)	BV _s Min (V _{rms})	Safety Standards (2)				
										UL	TÜV	VDE	BSI	IEC
TLP4172G		2.54SOP4 General-purpose	350	0.09	50	25	30	3	1500	○				
TLP4192G		2.54SOP6 General-purpose		0.09	50	25	30	3	1500	○				
TLP4222G		4-pin DIP General-purpose		0.1	50	25	30	3	2500	○				
TLP4592G		6-pin DIP General-purpose		0.1	50	25	30	3	2500	○				
TLP4176G		2.54SOP4 General-purpose		0.12	25	15	100	3	1500	○				
TLP4197G		2.54SOP6 General-purpose		0.12	25	15	100	3	1500	○				
TLP4227G		4-pin DIP General-purpose		0.15	25	15	100	3	2500	○				○
TLP4597G		6-pin DIP General-purpose		0.15	25	15	100	3	2500	○				○

MOSFET Output Devices, 2-Form-B

Part Number	Pin Configuration	Features	V _{OFF} Min (V)	I _{ON} Max (A)	R _{ON} Max (Ω)	R _{ON} Typ. (W)	Coff Typ. (pF)	I _{FT} Max (mA)	BV _s Min (V _{rms})	Safety Standards (2)				
										UL	TÜV	VDE	BSI	IEC
TLP4202G		2.54SOP8, 2 channels of the TLP4172G	350	0.09	50	25	30	3	1500	○				
TLP4222G-2		8-pin DIP, 2 channels of the TLP4222G		0.1	50	25	30	3	2500	○				
TLP4206G		2.54SOP8, 2 channels of the TLP4176G		0.12	25	15	100	3	1500	○				
TLP4227G-2		8-pin DIP, 2 channels of the TLP4227G		0.15	25	15	100	3	2500	○				○

MOSFET Output Devices, 1-Form-B + 1-Form-A

Part Number	Pin Configuration	Features	V _{OFF} Min (V)	I _{ON} Max (A)	R _{ON} Max (Ω)	R _{ON} Typ. (W)	Coff Typ. (pF)	I _{FT} Max (mA)	BV _s Min (V _{rms})	Safety Standards (2)				
										UL	TÜV	VDE	BSI	IEC
TLP4027G		2.54SOP8 1a1b (N.C. + N.O.) General-purpose	350	0.09	50	25	30	3	1500	○				
TLP4007G		8-pin DIP 1a1b (N.C. + N.O.) General-purpose		0.1	50	25	30	3	2500	○				
TLP4026G		2.54SOP8 1a1b (N.C. + N.O.) General-purpose		0.12	25	15	65	3	1500	○				
TLP4006G		8-pin DIP 1a1b (N.C. + N.O.) General-purpose		0.12	25	15	65	3	2500	○				

Note (2): In the safety standard column:

○: Approved ◎: SELV-approved △: Design which meets safety standard (as of November 2003) TÜV and VDE: VDE0884-approved with option D4 (It is changing into EN60747 from VDE0884.)

4.10 Products Manufactured by Toshiba Semiconductor (Thailand) Co., Ltd.

Part Number	Pin Configuration	Features	V _{CEO}	BV _s	Safety Standards ⁽²⁾				
					UL	TÜV	VDE	BSI	IEC
TLP180(T)		Mini-flat MFSOP6 AC input SEMKO-approved	80 V	3750 Vrms	○	○ ⁽¹⁾	△	⊙ EN 60950	△ 950
TLP181(T)		Mini-flat MFSOP6 SEMKO-approved General-purpose	80 V	3750 Vrms	○	△	○ ⁽¹⁾	⊙ EN 60950	△ 950
TLP521-1(T)		4-pin DIP pin General-purpose	55 V	2500 Vrms	○				
TLP521-2(T)		2 channels of the TLP521-1(T)			○				
TLP620(T)		4-pin DIP pin AC input SEMKO-approved	55 V	5000 Vrms	○	△ VDE 0884	⊙ 0884	⊙ EN 60065 EN 60950	△ 65 950
TLP620-2(T)		2 channels of the TLP620(T) SEMKO-approved			○	△ VDE 0884	⊙ 0884	⊙ EN 60065 EN 60950	
TLP621(T)		4-pin DIP pin High isolation voltage SEMKO-approved	55 V	5000 Vrms	○	△ VDE 0884	⊙ 0884	⊙ EN 60065 EN 60950	△ 65 950
TLP621-2(T)		2 channels of the TLP621(T) SEMKO-approved			○	△ VDE 0884	⊙ 8884	⊙ EN 60065 EN 60950	
TLP627(T)		4-pin DIP pin Darlington transistor output High V _{CEO} SEMKO-approved	300 V	5000 Vrms	○	△ VDE 0884	⊙ 0884	⊙ EN 60065 EN 60950	△ 65 950
TLP627-2(T)		2 channels of the TLP627(T) SEMKO-approved			○	△ VDE 0884	⊙ 0884	⊙ EN 60065 EN 60950	

Note (1): VDE0884 standards for mini-flat photocoupler are different from those for standard DIP photocouplers because mini-flat package is compact and small.
For details, please contact your nearest Toshiba sales office.

Note (2): In the safety standard column:

○: Approved ⊙: SELV-approved △: Design which meets safety standard (as of November 2003) TÜV and VDE: VDE0884-approved with option D4
(It is changing into EN60747 from VDE0884.)

Note that the products manufactured by Toshiba Semiconductor (Thailand) Co., Ltd. are not available in Japan.

5 Package Information

5.1 Package Dimensions

Unit: mm

DIP4

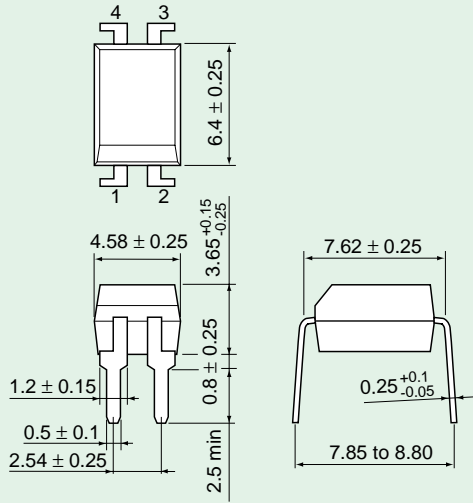

DIP4 (LF1)

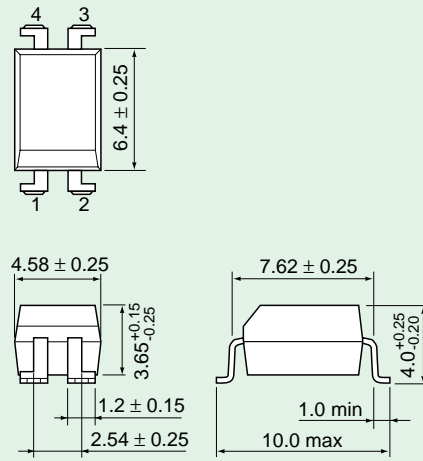

DIP4 (LF2)

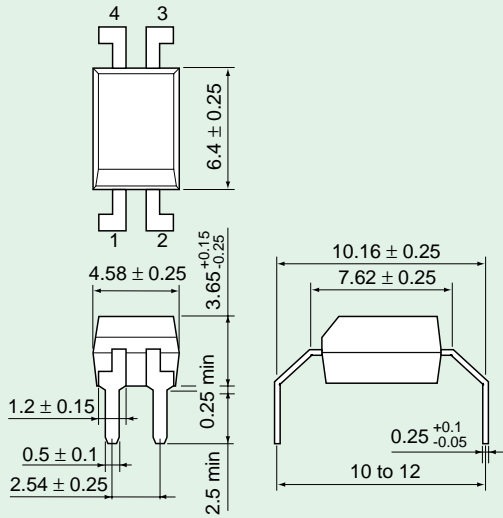

DIP4 (LF4)

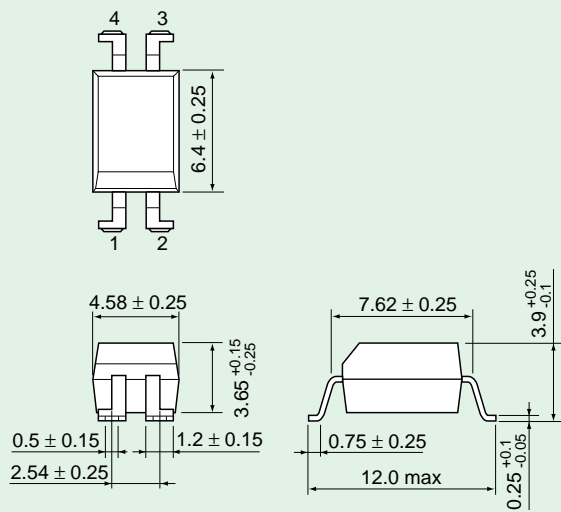

DIP4 (LF5)

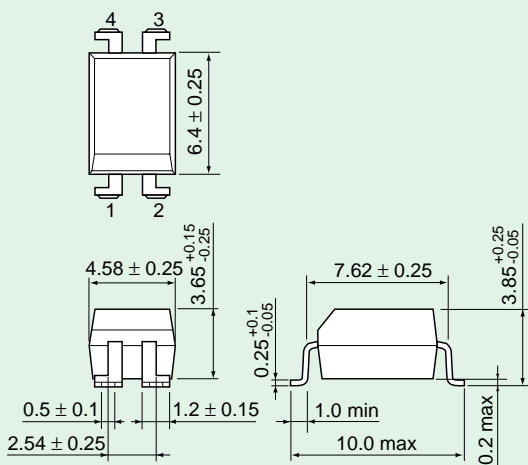

DIP6

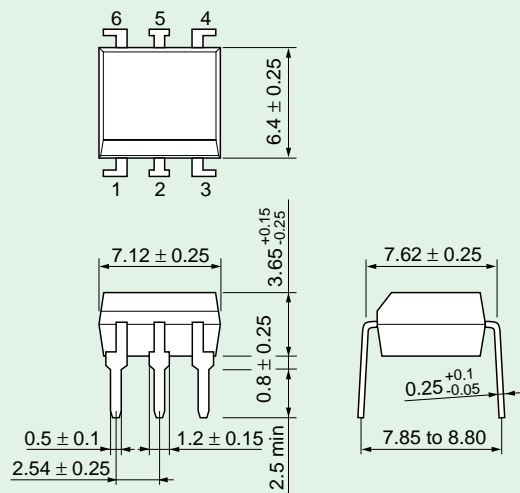

DIP6 (LF1)

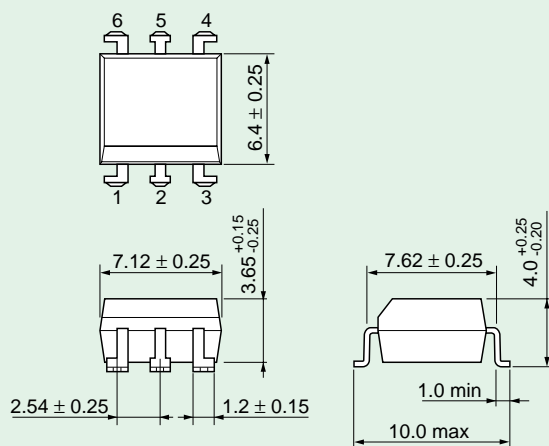

DIP6 (LF2)

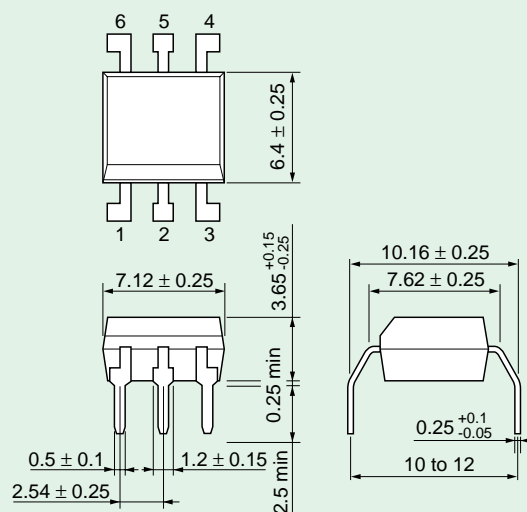

DIP6 (LF4)

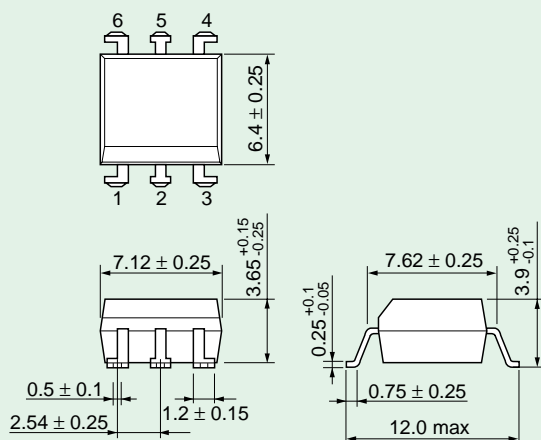

DIP6 (LF5)

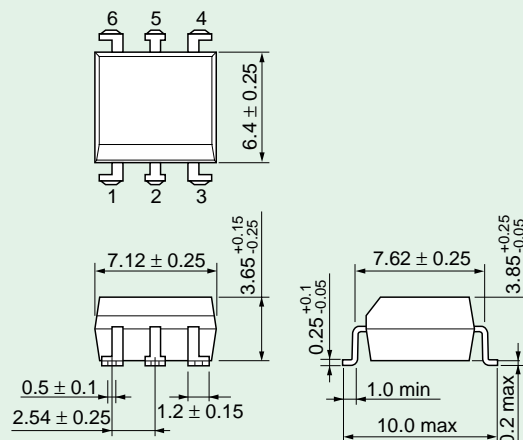

5-pin DIP6

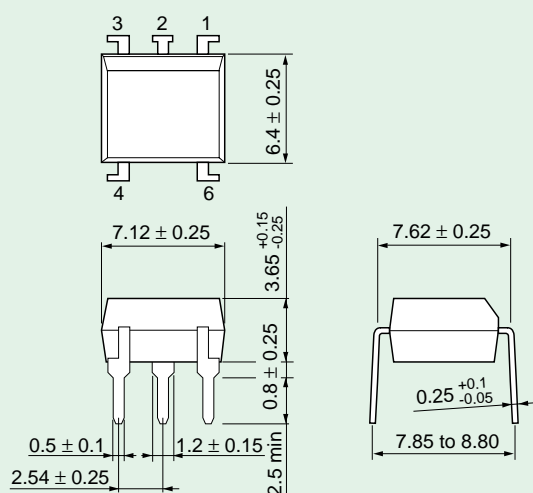

5-pin DIP6 (LF2)

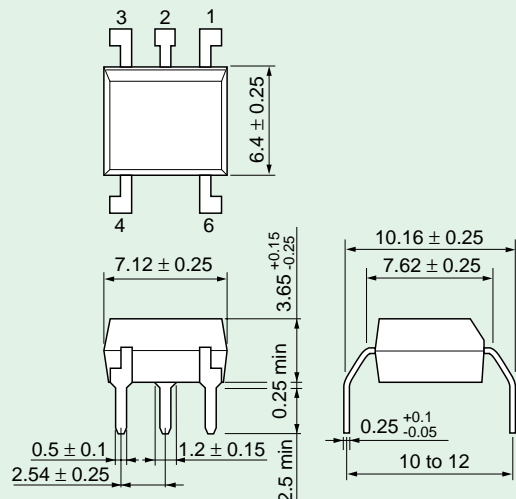

5 Package Information

5.1 Package Dimensions (continued)

Unit: mm

5-pin DIP (Cut)

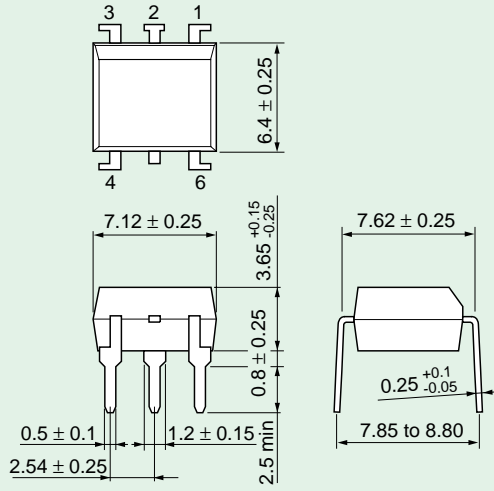

DIP8

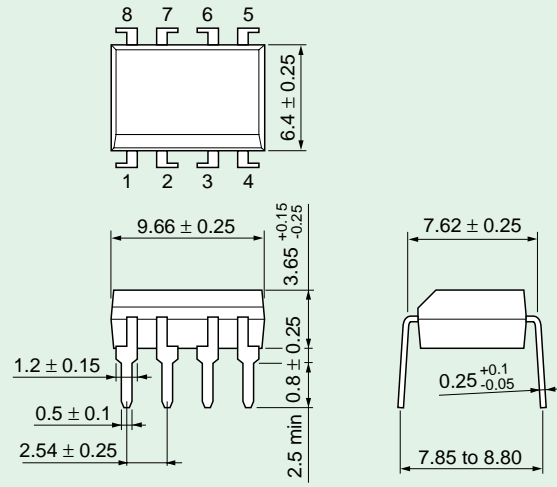

DIP8 (LF1)

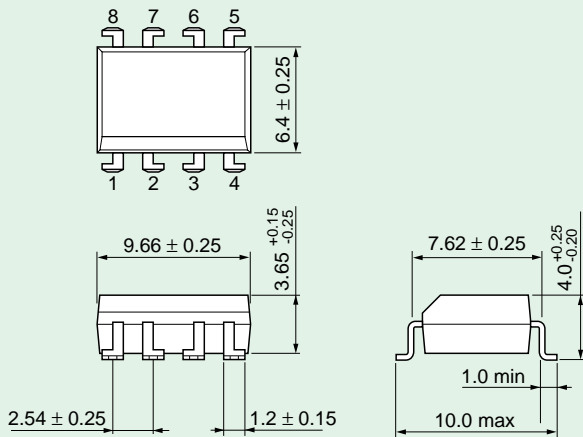

DIP8 (LF2)

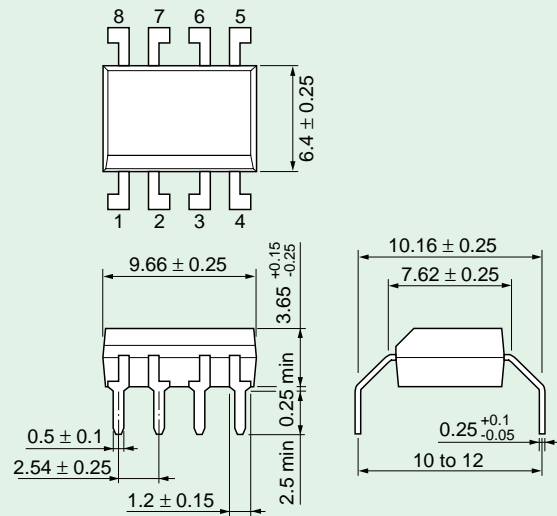

DIP8 (LF4)

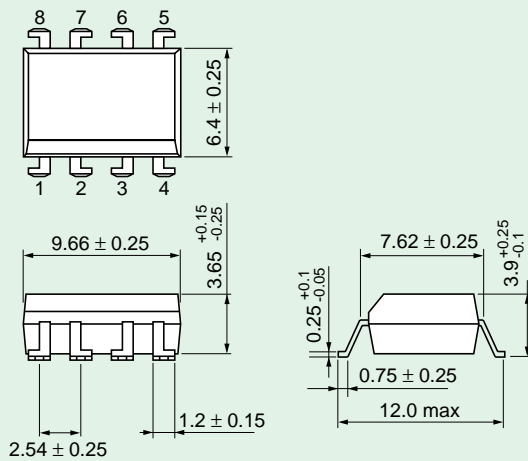

DIP16

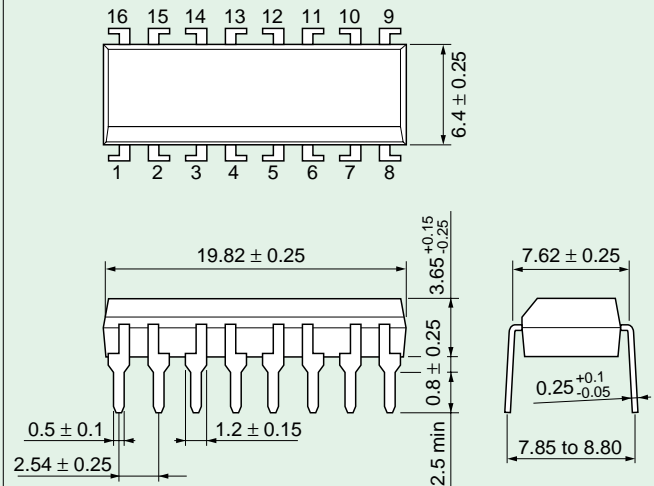

TLP3502, TLP3502A, TLP3503, TLP3506, TLP3507

TLP3520, TLP3520A, TLP3521, TLP3526, TLP3527

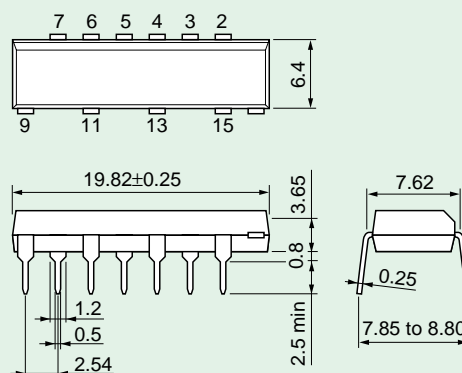
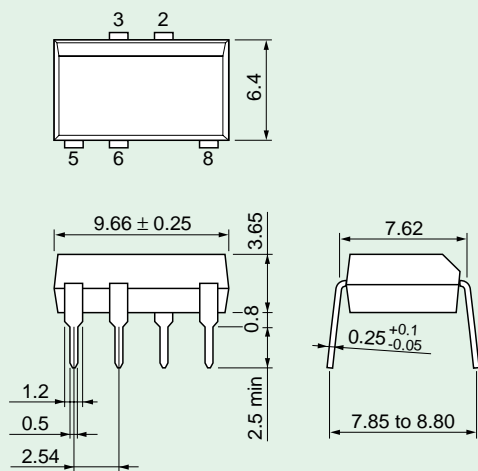

SDIP6

SDIP6 (F type)

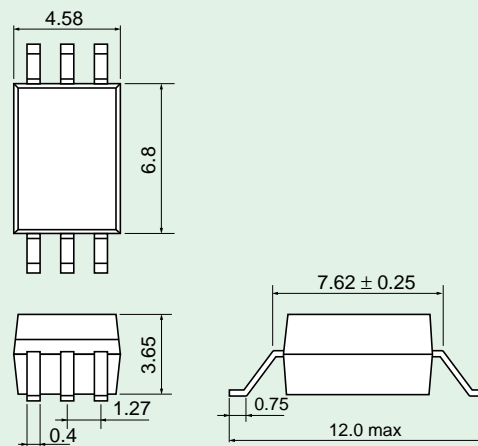
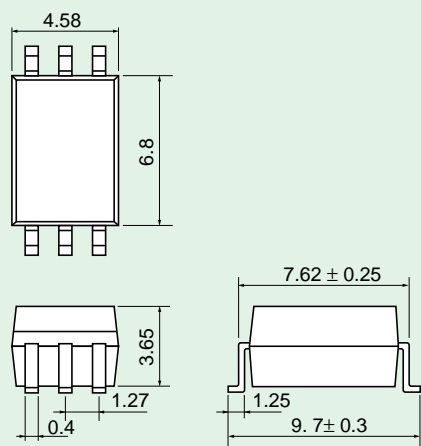

4-pin MFSOP6

5-pin MFSOP6

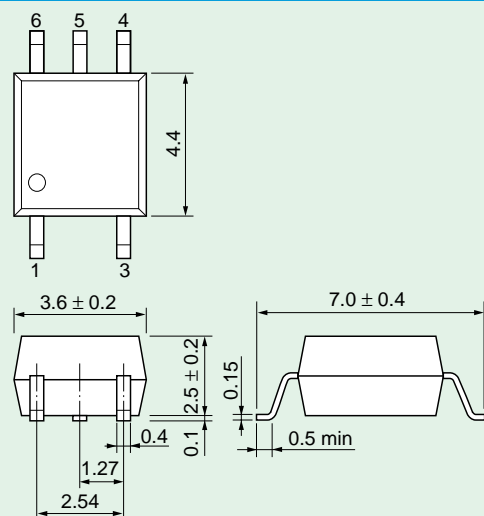
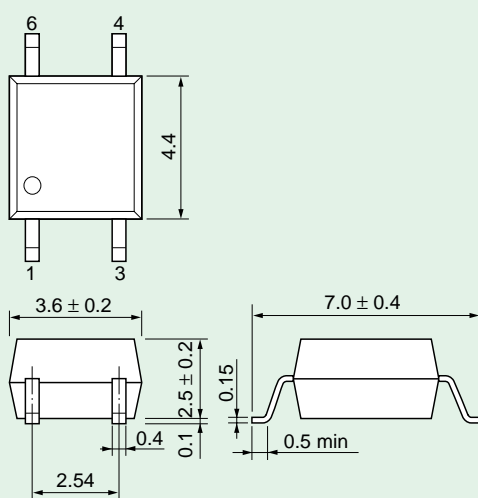

5 Package Information

5.1 Package Dimensions (continued)

Unit: mm

4-pin MFSOP6 (No.5Cut)

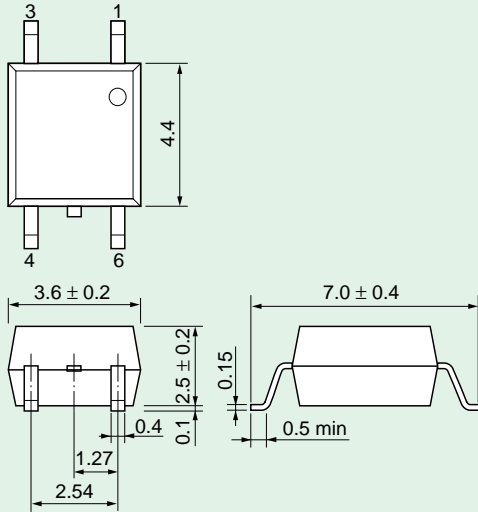

2.54SOP4

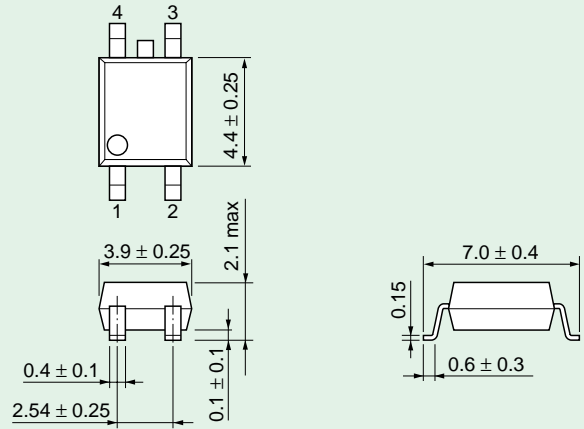

2.54SOP6

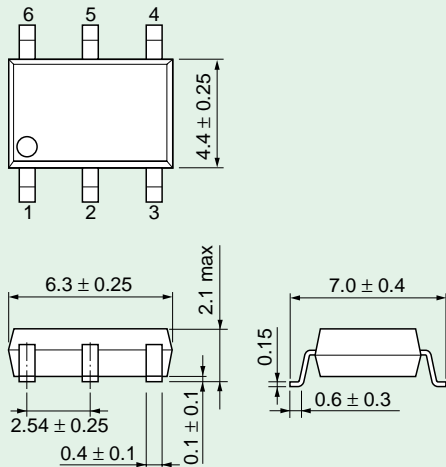

2.54SOP8

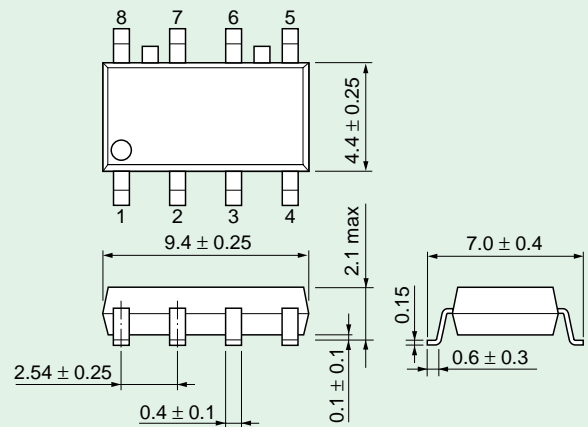

SOP4

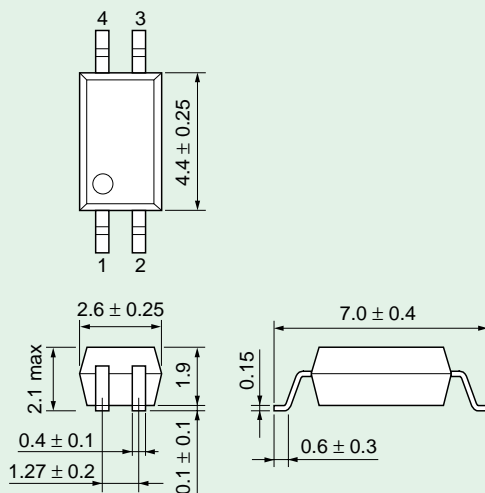

SOP16

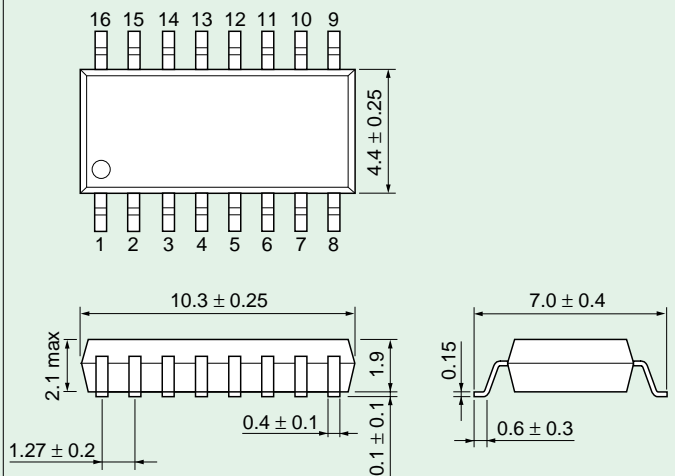

SSOP4

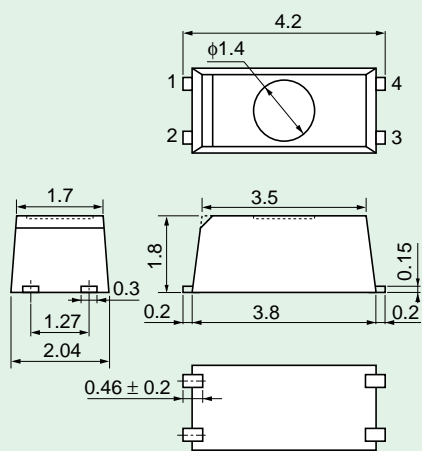

TLP3540

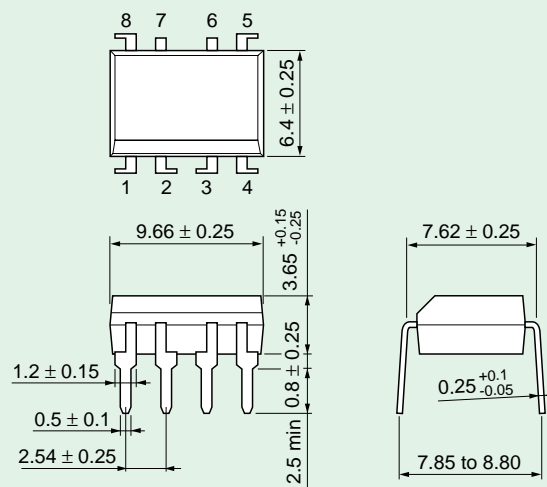

5 Package Information

5.2 Optional Lead Formed Products

1. Surface-Mount Lead Form Options (LF1), (LF4), (LF5)

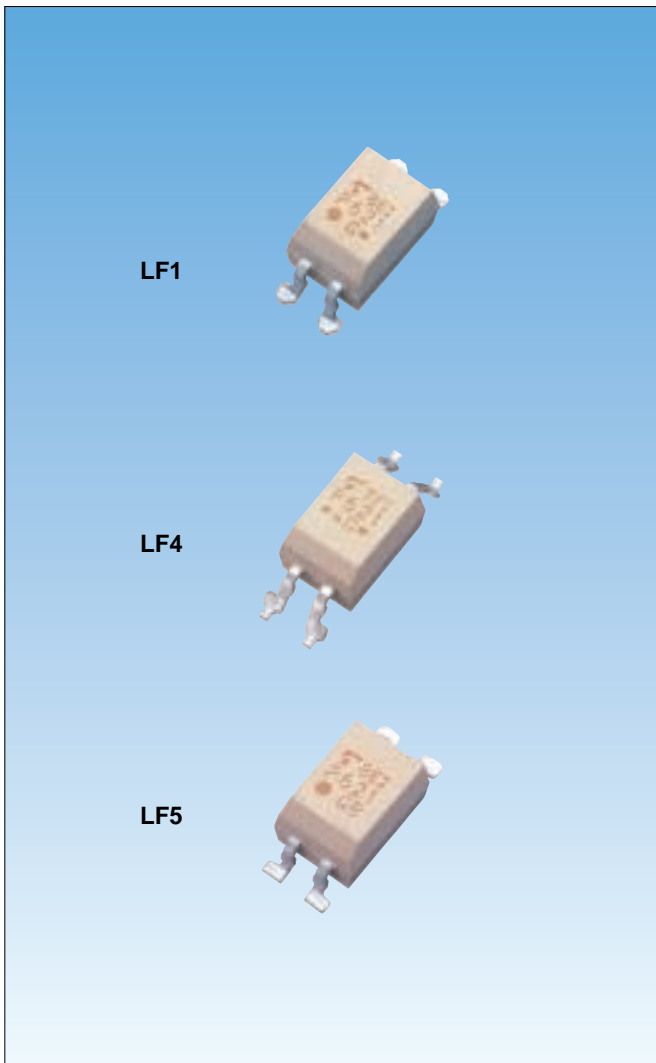

Package Outline

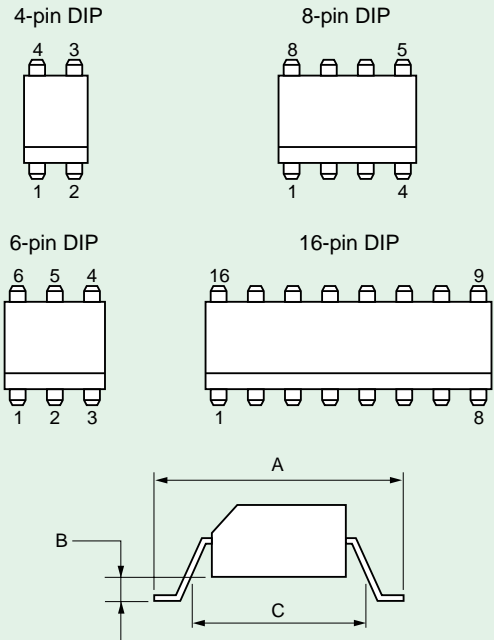

Dimensions

Unit: mm

Version	(LF1)		(LF4)		(LF5)	
	Min	Max	Min	Max	Min	Max
A	–	10.0	–	12.0	–	10.0
B	(0.35 typ.)		(0.25 typ.)		–	0.2
C	6.4	–	8.0	–	6.4	–

All other package dimensions are the same as for each standard package specifications.

Features

Surface-mountable: Leads of the photocouplers with (LF1), (LF4) or (LF5) part number suffix are available for all DIP packages except SDIP packages. These devices are suitable for hybrid circuits.

Applications: HIC modules, telephone exchanges, solid state relays, switching power supplies, inverter base amplifiers

This lead form option is available for all 4-, 6-, 8-, 12-, 16-pin DIP packages.

Ordering information

To order any standard photocoupler with a surface-mount lead form, add (LF1), (LF4) or (LF5) to the standard part number, depending on the lead form desired. When tape and reel packaging is desired, add (TP1), (TP4) or (TP5). Refer to 5.4 Tape and Reel Specifications for more details.

Example: Standard part number: TLP731 (GR)

Surface-mount type part number: TLP731 (GR-LF1), TLP731 (GR-LF4) or TLP731 (GR-LF5)

Safety Standard Approval

Use Toshiba standard part number for safety standards approved application.

Example $\frac{\text{Part number}}{\text{TLP731 (GR-LF1)}} \longrightarrow \frac{\text{Approved part number}}{\text{TLP731}}$

Note: For more details about package dimensions, please refer to 5.1 Package Dimensions.

2. Wide-Spaced Lead Form Option (LF2)

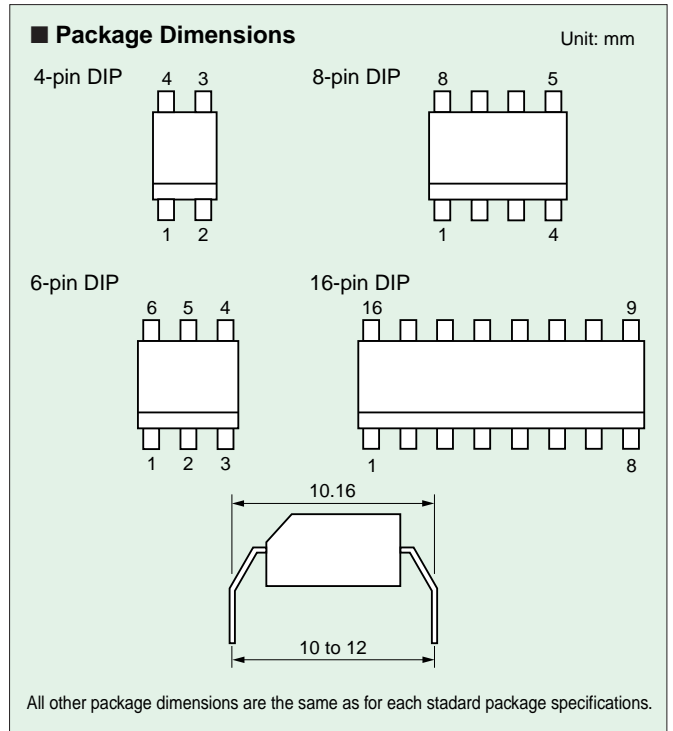
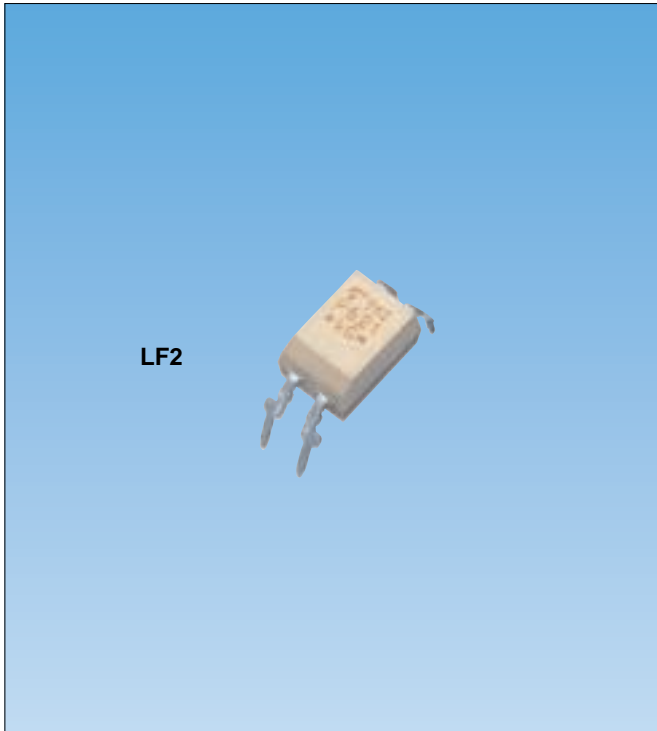

■ Features

Wide-spaced surface-mountable: Leads of the DIP packaged photocouplers with (LF2) part number suffix are bend to satisfy 8-mm PC board spacing requirements.

Applications: Office equipment, home appliances, solid state relays, switching power supplies The lead form option is available for all 4-, 6-, 8-, 12-, 16-pin DIP packages with electrical characteristics remain unchanged.

■ Ordering information

To order any standard photocoupler with wide-spaced lead form, add (LF2) to the standard part number.

Example: Standard part number: TLP731 (GR)

Wide-spaced part number: TIP731 (GR-LF2)

■ Safety Standard Approval

Use Toshiba standard part number for safety standards approved application.

Example $\frac{\text{Part number}}{\text{TLP731 (GR-LF2)}} \longrightarrow \frac{\text{Approved part number}}{\text{TLP731}}$

Note: For more details about package dimensions, please refer to 5.1 Package Dimensions.

5 Package Information

5.3 Photocoupler Magazine Packing Specifications

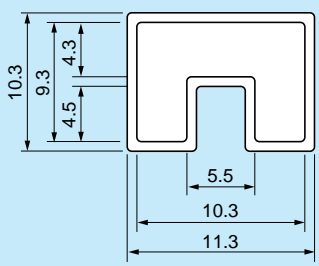
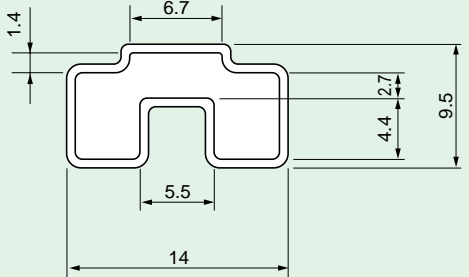
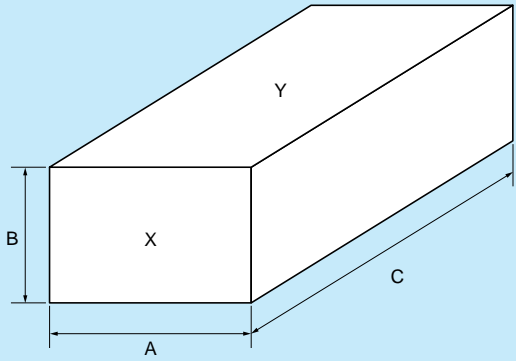
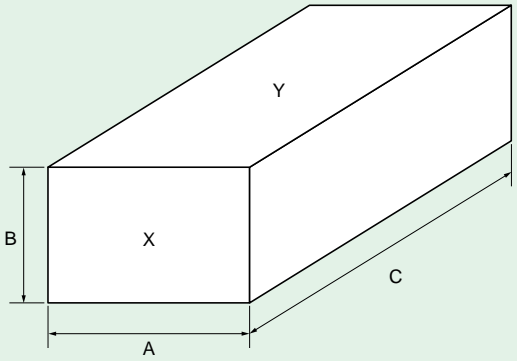
	Standard DIP	DIP LF1, LF2, LF4 and LF5 Lead Forming																					
Dimensions of Magazine	<p style="text-align: right;">Unit: mm</p>  <p style="text-align: center;">Length = 525 Thickness = 0.5</p>	<p style="text-align: right;">Unit: mm</p>  <p style="text-align: center;">Length = 525 Thickness = 0.5</p>																					
Quantities of Devices per Magazine	<table border="1" style="width: 100%; text-align: center;"> <tr> <td style="background-color: #0070C0; color: white;">Number of Pins</td> <td style="background-color: #0070C0; color: white;">4</td> <td style="background-color: #0070C0; color: white;">6</td> <td style="background-color: #0070C0; color: white;">8</td> <td style="background-color: #0070C0; color: white;">12</td> <td style="background-color: #0070C0; color: white;">16</td> </tr> <tr> <td style="background-color: #D9E1F2;">Quantity (pcs)</td> <td style="background-color: #FFF2CC;">100</td> <td style="background-color: #FFF2CC;">50</td> <td style="background-color: #FFF2CC;">50</td> <td style="background-color: #FFF2CC;">25</td> <td style="background-color: #FFF2CC;">25</td> </tr> </table>		Number of Pins	4	6	8	12	16	Quantity (pcs)	100	50	50	25	25									
Number of Pins	4	6	8	12	16																		
Quantity (pcs)	100	50	50	25	25																		
Packing Dimensions	<p style="text-align: right;">Unit: mm</p>  <table border="1" style="width: 100%; text-align: center; margin-top: 20px;"> <thead> <tr> <th style="background-color: #0070C0; color: white;">Quantity of Magazines</th> <th style="background-color: #0070C0; color: white;">Dimensions (A x B x C)</th> <th style="background-color: #0070C0; color: white;">Label Position</th> </tr> </thead> <tbody> <tr> <td style="background-color: #D9E1F2;">4</td> <td style="background-color: #FFF2CC;">50 x 12 x 531</td> <td style="background-color: #FFF2CC;">Y</td> </tr> <tr> <td style="background-color: #D9E1F2;">20</td> <td style="background-color: #FFF2CC;">67 x 51 x 559</td> <td style="background-color: #FFF2CC;">Y</td> </tr> <tr> <td style="background-color: #D9E1F2;">60</td> <td style="background-color: #FFF2CC;">123 x 76 x 568</td> <td style="background-color: #FFF2CC;">X</td> </tr> </tbody> </table>	Quantity of Magazines	Dimensions (A x B x C)	Label Position	4	50 x 12 x 531	Y	20	67 x 51 x 559	Y	60	123 x 76 x 568	X	<p style="text-align: right;">Unit: mm</p>  <table border="1" style="width: 100%; text-align: center; margin-top: 20px;"> <thead> <tr> <th style="background-color: #0070C0; color: white;">Quantity of Magazines</th> <th style="background-color: #0070C0; color: white;">Dimensions (A x B x C)</th> <th style="background-color: #0070C0; color: white;">Label Position</th> </tr> </thead> <tbody> <tr> <td style="background-color: #D9E1F2;">4</td> <td style="background-color: #FFF2CC;">60 x 13 x 531</td> <td style="background-color: #FFF2CC;">Y</td> </tr> <tr> <td style="background-color: #D9E1F2;">40</td> <td style="background-color: #FFF2CC;">135 x 58 x 568</td> <td style="background-color: #FFF2CC;">X</td> </tr> </tbody> </table>	Quantity of Magazines	Dimensions (A x B x C)	Label Position	4	60 x 13 x 531	Y	40	135 x 58 x 568	X
Quantity of Magazines	Dimensions (A x B x C)	Label Position																					
4	50 x 12 x 531	Y																					
20	67 x 51 x 559	Y																					
60	123 x 76 x 568	X																					
Quantity of Magazines	Dimensions (A x B x C)	Label Position																					
4	60 x 13 x 531	Y																					
40	135 x 58 x 568	X																					

	Mini-Flat Coupler (MFP)	SOP Photocoupler																				
Dimensions of Magazine	<p style="text-align: right;">Unit: mm</p> <p style="text-align: center;">Length = 555 Thickness = 0.5</p>	<p style="text-align: right;">Unit: mm</p> <p style="text-align: center;">Length = 555 Thickness = 0.5</p>																				
Quantities of Devices per Magazine	<table border="1" style="width: 100%; text-align: center;"> <tr> <td style="background-color: #add8e6;">Number of Pins</td> <td style="background-color: #ffffcc;">4 (MFSOP4)</td> </tr> <tr> <td style="background-color: #add8e6;">Quantity (pcs)</td> <td style="background-color: #ffffcc;">150</td> </tr> </table>	Number of Pins	4 (MFSOP4)	Quantity (pcs)	150	<table border="1" style="width: 100%; text-align: center;"> <tr> <td style="background-color: #add8e6;">Number of Pins</td> <td style="background-color: #ffffcc;">4 (SOP4)</td> <td style="background-color: #ffffcc;">16 (SOP16)</td> <td style="background-color: #ffffcc;"></td> </tr> <tr> <td style="background-color: #add8e6;">Quantity (pcs)</td> <td style="background-color: #ffffcc;">150</td> <td style="background-color: #ffffcc;">50</td> <td style="background-color: #ffffcc;"></td> </tr> <tr> <td style="background-color: #add8e6;">Number of Pins</td> <td style="background-color: #ffffcc;">4 (2.54SOP4)</td> <td style="background-color: #ffffcc;">6 (2.54SOP6)</td> <td style="background-color: #ffffcc;">8 (2.54SOP8)</td> </tr> <tr> <td style="background-color: #add8e6;">Quantity (pcs)</td> <td style="background-color: #ffffcc;">100</td> <td style="background-color: #ffffcc;">75</td> <td style="background-color: #ffffcc;">50</td> </tr> </table>	Number of Pins	4 (SOP4)	16 (SOP16)		Quantity (pcs)	150	50		Number of Pins	4 (2.54SOP4)	6 (2.54SOP6)	8 (2.54SOP8)	Quantity (pcs)	100	75	50
Number of Pins	4 (MFSOP4)																					
Quantity (pcs)	150																					
Number of Pins	4 (SOP4)	16 (SOP16)																				
Quantity (pcs)	150	50																				
Number of Pins	4 (2.54SOP4)	6 (2.54SOP6)	8 (2.54SOP8)																			
Quantity (pcs)	100	75	50																			
Packing Dimensions		<p style="text-align: right;">Unit: mm</p> <table border="1" style="width: 100%; text-align: center;"> <thead> <tr> <th style="background-color: #add8e6;">Quantity of Magazines</th> <th style="background-color: #add8e6;">Dimensions (A x B x C)</th> <th style="background-color: #add8e6;">Label Position</th> </tr> </thead> <tbody> <tr> <td style="background-color: #add8e6;">4</td> <td style="background-color: #ffffcc;">29 x 13 x 563</td> <td style="background-color: #ffffcc;">Y</td> </tr> <tr> <td style="background-color: #add8e6;">24</td> <td style="background-color: #ffffcc;">77 x 31 x 586</td> <td style="background-color: #ffffcc;">Y</td> </tr> <tr> <td style="background-color: #add8e6;">60</td> <td style="background-color: #ffffcc;">67 x 55 x 586</td> <td style="background-color: #ffffcc;">X</td> </tr> </tbody> </table>	Quantity of Magazines	Dimensions (A x B x C)	Label Position	4	29 x 13 x 563	Y	24	77 x 31 x 586	Y	60	67 x 55 x 586	X								
Quantity of Magazines	Dimensions (A x B x C)	Label Position																				
4	29 x 13 x 563	Y																				
24	77 x 31 x 586	Y																				
60	67 x 55 x 586	X																				

Photocoupler Package Type		Typical Devices
MFC	A	TLP114A, TLP160J, TLP180, TLP190B
SOP	B	TLP280, TLP281
	C	TLP280-4, TLP281-4, TLP270D, TLP270G
	D	TLP176G, TLP176A
	E	TLP197G
	F	TLP206G, TLP206A

- A: MFSOP6
- B: SOP4
- C: SOP16
- D: 2.54SOP4
- E: 2.54SOP6
- F: 2.54SOP8

5 Package Information

5.4 Tape and Reel Specifications

1. Embossed Tape Packaging Specifications for Surface-Mount Lead Form Options

Photocoupler Package Types	Tape Option Symbol	Typical Devices
MFSOP6	(TPL) or (TPR)	TLP114A, TLP165J, TLP181, TLP190B
SOP4	(TP)	TLP280, TLP281
SOP16	(TP)	TLP280-4, TLP281-4, TLP270D, TLP270G
2.54SOP4	(TP)	TLP176G, TLP176A, TLP176D
2.54SOP6	(TP)	TLP197G
2.54SOP8	(TP)	TLP200D, TLP206A, TLP206G
SSOP4	(TP15)	TLP3213 to 3217, TLP3230, TLP3231
DIP(LF1, LF5)	(TP1) or (TP5)	TLP550, TLP560G, TLP421
DIP(LF4)	(TP4)	TLP251, TLP560G, TLP421

2. Tape Dimensions

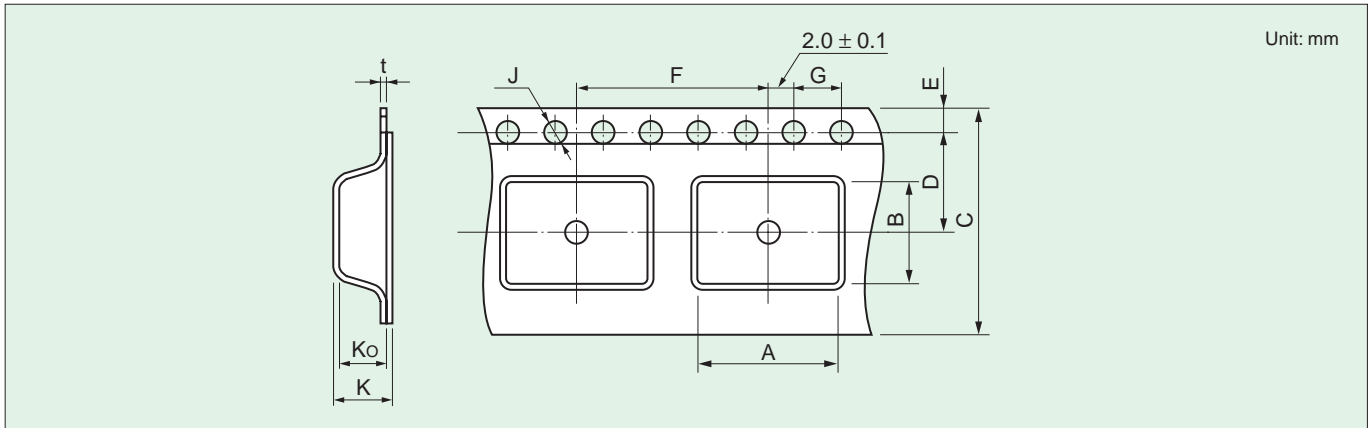

Photocoupler Package Type	MFSOP6	SOP4	SOP16	2.54SOP4	2.54SOP6	2.54SOP8	SSOP4	DIP(LF1,LF5)	DIP(LF4)	
Tape Option	(TPL), (TPR)	(TP)	(TP)	(TP)	(TP)	(TP)	(TP15)	(TP1),(TP5)	(TP4)	
Symbol (See Figure above)	A	4.2 ± 0.1	3.1 ± 0.1	7.5 ± 0.1	4.3 ± 0.1	7.5 ± 0.1		2.35 ± 0.2	10.4 ± 0.1	12.3 ± 0.1
	B	7.6 ± 0.1	7.5 ± 0.1	10.5 ± 0.1	7.5 ± 0.1	6.7 ± 0.1	10.5 ± 0.1	4.5 ± 0.1	*1	*1
	C	12.0 ± 0.3		16.0 ± 0.3	12.0 ± 0.3	16.0 ± 0.3		12.0 ± 0.3	16.0 ± 0.3	
	D	5.5 ± 0.1		7.5 ± 0.1	5.5 ± 0.1	7.5 ± 0.1		5.5 ± 0.1	7.5 ± 0.1	
	E	1.75 ± 0.1								
	F	8.0 ± 0.1		12.0 ± 0.1	8.0 ± 0.1	12.0 ± 0.1		4.0 ± 0.1	12.0 ± 0.1	16.0 ± 0.1
	G	4.0 ± 0.1								
	J	1.5 ^{+0.1} ₋₀								
	K	3.15 ± 0.2	2.5 ± 0.2	2.4 ± 0.2	2.6 ± 0.2	2.5 ± 0.2	2.4 ± 0.2	2.4 ± 0.2	4.55 ± 0.2	
	K0	2.8 ± 0.1	2.3 ± 0.1	2.2 ± 0.1	2.4 ± 0.1	2.3 ± 0.1	2.2 ± 0.1	2.1 ± 0.1	4.1 ± 0.1	
	t	0.3 ± 0.05								0.4 ± 0.05

*1: Typical devices

DIP4	TLP620, TLP421, TLP721	5.1 ± 0.1
DIP6 (short package)	TLP631, TLP734, TLP747G	7.6 ± 0.1
DIP6 (long package)	TLP595G, TLP666G, TLP3020	10.1 ± 0.1 (TP4) is not available.
DIP8	TLP250, TLP555, TLP2601	

3. Reel Dimensions

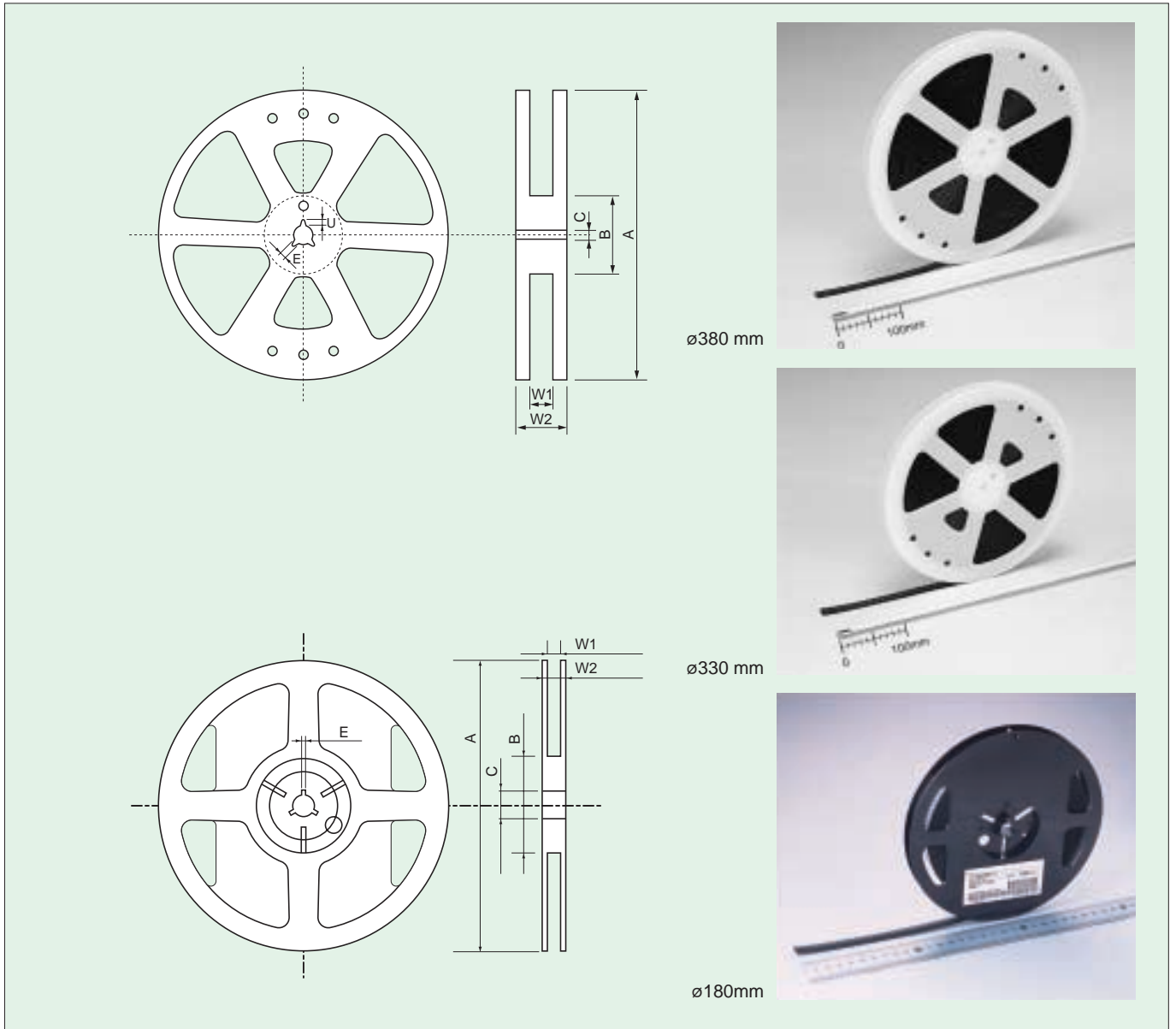

Unit: mm

Photocoupler Package Type		MFSOP	SOP4	SOP16	2.54SOP4	2.54SOP6	2.54SOP8	SSOP4	DIP(LF1, LF5)	DIP(LF4)
Tape Option		(TPL), (TPR)	(TP)	(TP)	(TP)			(TP15)	(TP1), (TP5)	(TP4)
Symbol (See Figure above)	A	Dimensions	ø380 ± 2		ø330 ± 2			180 ⁺⁰ ₋₄	ø380 ± 2	
	B		ø80 ± 1		ø60			ø80 ± 1		
	C		ø13 ± 0.5		ø13			ø13 ± 0.5		
	E		2.0 ± 0.5		2 ± 0.5			2.0 ± 0.5		
	U		4.0 ± 0.5		4.0 ± 0.5			4.0 ± 0.5		
	W1		13.5 ± 0.5	17.5 ± 0.5	13.5 ± 0.5	17.5 ± 0.5		13 ± 0.3	17.5 ± 0.5	
	W2		17.5 ± 1.0	21.5 ± 1.0	17.5 ± 1.0	21.5 ± 1.0		15.4 ± 1.0	21.5 ± 1.0	

5 Package Information

4. Other Packing Information

(a) Device orientation on tape

The orientations of photocouplers in cavity are shown below.

Photocoupler Package Type	Tape Option
MFSOP6	TPR

A)

Photocoupler Package Type	Tape Option
MFSOP6	TPL
SOP4, 2.54SOP4	TP
SSOP4	TP15

B)

Photocoupler Package Type	Tape Option
SOP16	TP
2.54SOP6/8	TP
DIP (LF1, LF5)	TP1, TP5
DIP (LF4)	TP4

C)

(b) Taping Specifications

● Quantities per Reel

Photocoupler Package Type	MFSOP6	SOP4	SOP16	2.54SOP4/6/8	SSOP4	DIP (LF1, LF5)	DIP (LF4)
Quantities (pcs)	3000	2500	2500	2500	1500	1500	1000

● Empty Cavities :

Item	Specification	Note
Consecutive empty cavities	Zero	Any 40 mm portion of tape except leader and trailer.
Nonconsecutive empty cavities	0.2% max/reel *2	Except leader and trailer.

*2: 6 pcs max/reel for DIP types

(c) Packing boxes

2 types: One-reel box or five-reel box.

(d) Label

The reel label includes the following information.

1. Part number 2. Tape type 3. Quantity 4. Lot number

(e) Purchase order

Specify the part number, tape and quantity as follows.

Example **TLP181 (GB - TPR) 3000 pcs**

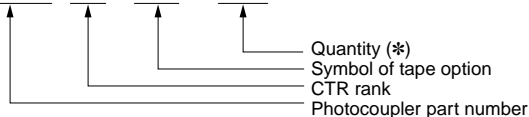

*Per reel must be a multiple of quantity

5.5 PC Board Mounting for Mini-Flat Coupler, SOP Coupler and Lead Formed Coupler

1. Recommended Footprint Dimensions

Below are the recommended footprint (mount pad) dimensions for surface-mount packages.

Mini-flat coupler and SOP coupler

(Unit: mm)

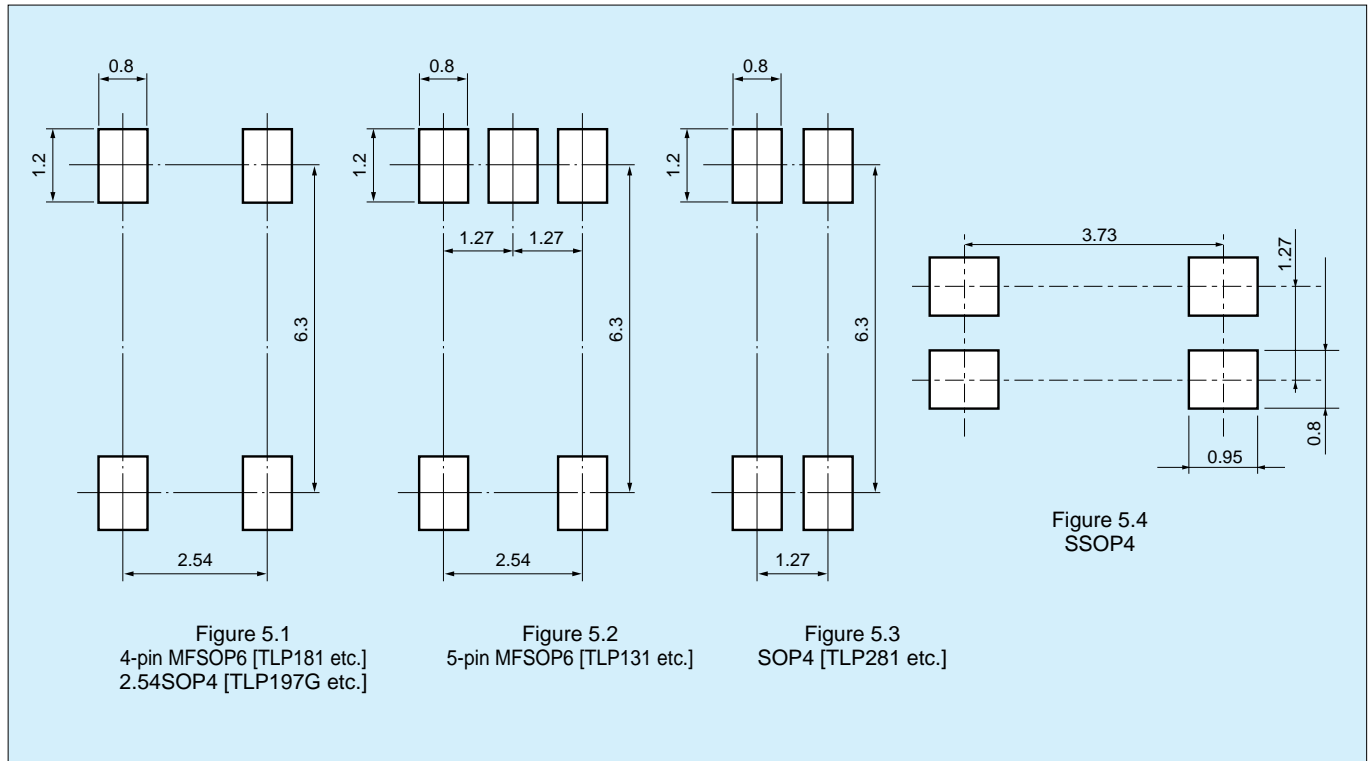

Surface-Mount Lead-Formed Coupler (Example: 6-pin DIP package)

(Unit: mm)

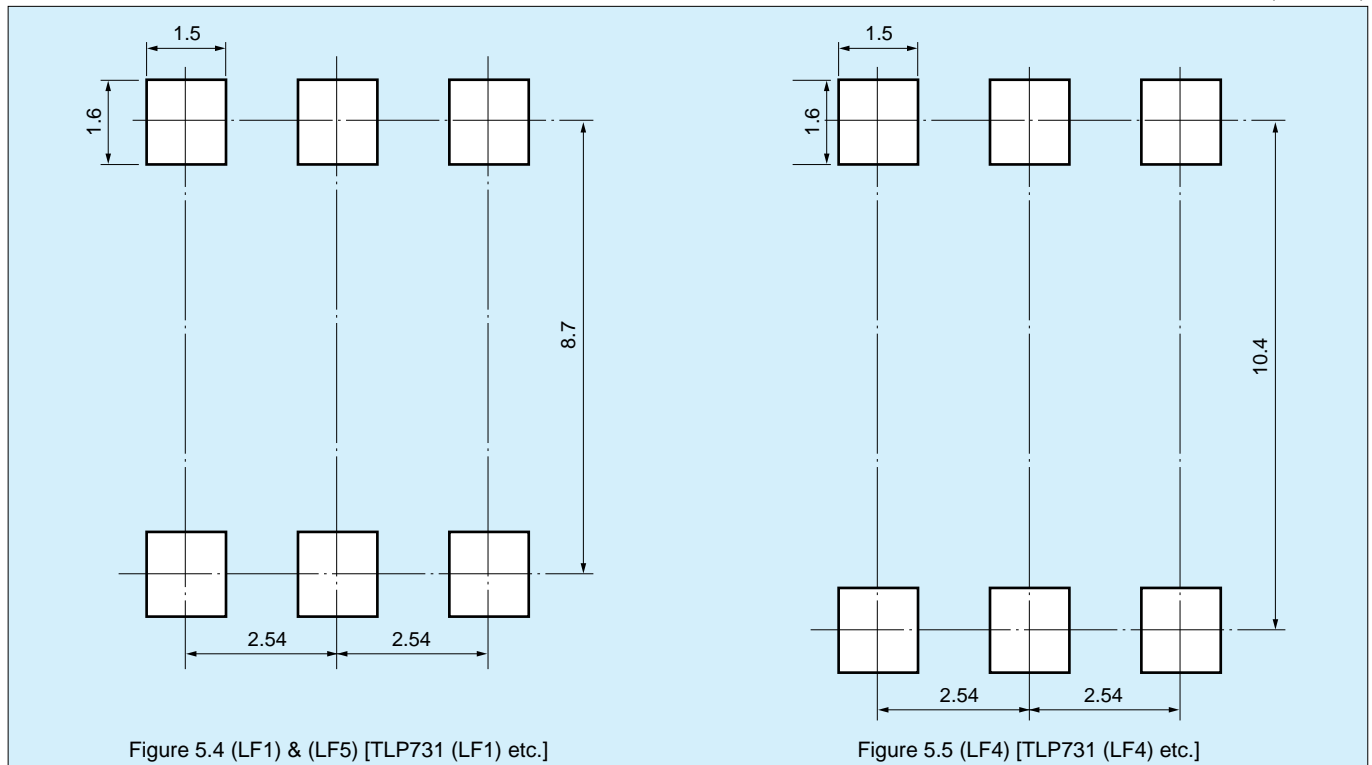

5 Package Information

2. Soldering

When using a soldering iron or medium infrared ray/hot air reflow, avoid rise in device temperature as much as possible by observing the following conditions.

2.1) Using a soldering iron

Complete soldering within ten seconds for lead temperature of up to 260°C.

2.2) Using medium infrared ray/hot air reflow

a. Complete the infrared ray/hot air reflow process within 30 seconds at a package surface temperature of between 210°C and 240°C.

b. Refer to the figure below for an example of a good temperature profile for medium infrared ray/hot air reflow.

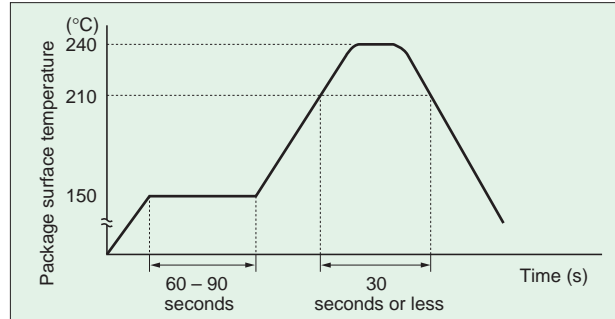

c. Precautions for heating

If packages have been kept at high temperature for a long period of time, it can degrade the quality and reliability of devices. Soldering time has to be kept as short as possible to avoid rise in package temperature.

When using a halogen lamp or infrared heater, avoid direct irradiation to packages, as this may cause rise in package temperature.

2.3) Dip soldering (Flow soldering)

The thermal shock of the dip soldering is intended to increase thermal stress to devices. To avoid the stress, a soldering iron or medium infrared ray/hot air reflow is recommended. When dip soldering is considered, please contact your nearest Toshiba sales office.

3. Flux Cleaning

- When cleaning circuit boards to remove flux, make sure that no residual reactive ions such as Na or Cl remain. Note that organic solvents react with water to generate hydrogen chloride and other corrosive gases which can degrade device performance.
- Washing devices with water will not cause any problems. However, make sure that no reactive ions such as sodium and chlorine are left as residue. Also, be sure to dry devices sufficiently after washing.
- Do not rub device markings with a brush or with your hand during cleaning or while the devices are still wet from the cleaning agent. Doing so can rub off the markings.
- The dip cleaning, shower cleaning and steam cleaning processes all involve the chemical action of a solvent. Use only recommended solvents for these cleaning methods. When immersing devices in a solvent or steam bath, make sure that the temperature of the liquid is 50°C or below, and that the circuit board is removed from the bath within one minute.
- If a device package allows ultrasonic cleaning, limit the duration of ultrasonic cleaning to as short as possible, since long hours of ultrasonic cleaning degrade the adhesion between the mold resin and the frame material.

The following ultrasonic cleaning conditions are recommended.

Frequency: 27 kHz to 29 kHz
Ultrasonic output power: 300 W or less (0.25 W/cm² or less)
Cleaning time: 30 seconds or less

Suspend the circuit board in the solvent bath during ultrasonic cleaning in such a way that the ultrasonic vibrator does not come into direct contact with the circuit board or the device.

Conventional cleaning solvents that contain Freon are not recommended due to the danger that they pose to the earth's ozone layer. Alternative products are available on the market. Some alternative cleaning agents that do not contain Freon listed in Table below.

Contact Toshiba or a Toshiba distributor regarding cleaning conditions and other relevant information for each product type.

Example of Alternative Cleaning Agents

Technocare	FRW-1, FRW-17, FRV-100	from Toshiba Corporation
Asahi Clean	AK-225AES	from Asahi Glass Co., Ltd
Clean Through	750H	from Kao Co., Ltd.
Pine Alpha	ST-100S, ST-100SX	from Arakawa Chemical Co., Ltd.

6 Supplementary Information

6.1 Current Transfer Ratio (CTR), LED Trigger Current (I_{FT}) Ranking and Marking

Standard rank classifications are applied for the CTR of transistor output devices and for the I_{FT} of MOSFET, SCR, Triac output devices. Indicative product markings corresponding to rank names are as shown below.

Also, note that the applied rank classifications depend on product types. For details, refer to relevant technical datasheets.

1. CTR Rank Name and Rank Marking

Available CTR Rank Selection (○: Available, △: Call Toshiba)

Part Number	Rank Name									Rank Marking Group
	None	GB	Y	GR	BL	YH	GRL	GRH	BLL	
TLP180	○	○	△	○	△					①
TLP181	○	○	○	○	○	○	○	○	○	②
TLP280	○	○	△	○	△					①
TLP280-4	○	○								③
TLP281	○	○	○	○	○	○	○	○	○	②
TLP281-4	○	○								③
TLP321	○	○	○	○	○					②
TLP321-2	○	○		○	△					①
TLP321-4	○	○								③
TLP421/421F	○	○	○	○	○	○	○	○	○	TLP421
TLP521-1	○	○	○	○	○	○	○	○	○	②
TLP521-2	○	○	△	○	△					①
TLP521-4	○	○								③
TLP531/532	○	○	△	○	△					①
TLP620	○	○	△	○	△					①
TLP620-2	○	○								③
TLP620-4	○	○								③
TLP621	○	○	○	○	○	○	○	○	○	②
TLP621-2	○	○	△	○	△					①
TLP621-4	○	○								③
TLP630	○	○	△	○	△					①
TLP631/632	○	○	△	○	△					②
TLP721	○	○	△	○	△	○	○	○	○	②
TLP731/732	○	○	△	○	△					②
TLP733F/734F	○	○	△	○	△					②

*Blank list by part number

Rank Name	CTR	CTR	
		Other than TLP421	TLP421
None	50 to 600%	*Refer to Blank list by part number.	Blank, Y, Y+, YE, G, G+, GR, B, B+, BL, GB
Y	50 to 150%	YE	YE
GR	100 to 300%	GR	GR
GB	100 to 600%	GB	BL
BL	200 to 600%	BL	GB
YH	75 to 150%	Y■	Y+
GRL	100 to 200%	G	G
GRH	150 to 300%	G■	G+
BLL	200 to 400%	B	B

Part Number	Blank	Rank Marking Group	Part Number	Blank	Rank Marking Group
TLP180	Blank, YE, GR, BL, GB	①	TLP280-4	Blank, GB	③
TLP280					
TLP321-2					
TLP521-2					
TLP531/532					
TLP620					
TLP621-2					
TLP630					
TLP181					
TLP281					
TLP321	Blank, Y, Y■, YE, G, G■, GR, B, B■, BL, GB	②			
TLP521-1					
TLP531					
TLP621					
TLP631					
TLP632					
TLP721					
TLP731					
TLP732					
TLP733F					
TLP734F					

6.1 LED Trigger Current (IFT) Ranking and Marking

2. IFT Rank Name and Rank Marking

Rank Name	IFT	IFT Rank Marking
None	IFT max	Blank, T7, T5
IFT7	7 mA max	T7, T5
IFT5	5 mA max	T5
IFT2	2 mA max	T2 (only for photorelays)

3. Marking Example

(a) 4-pin Type & Mini-Flat 1-ch Type

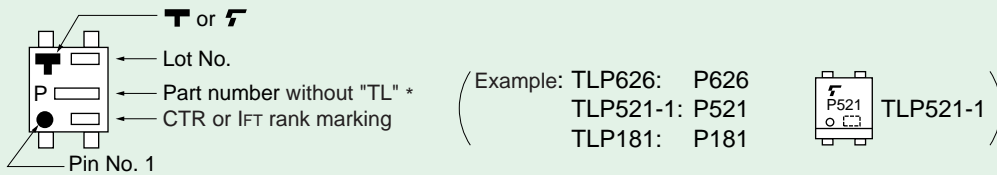

(b) TLP421, TLP421F

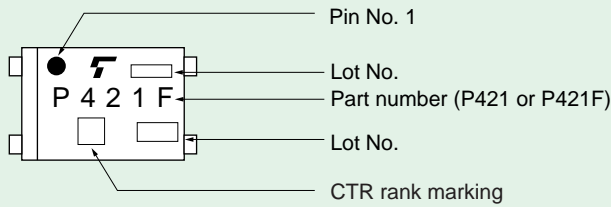

(c) TLP280, TLP281

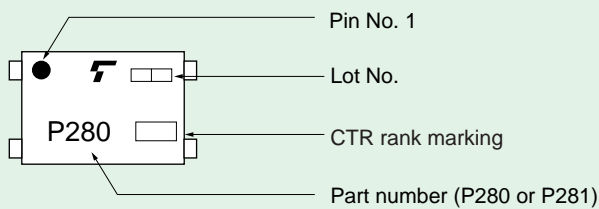

(d) Others

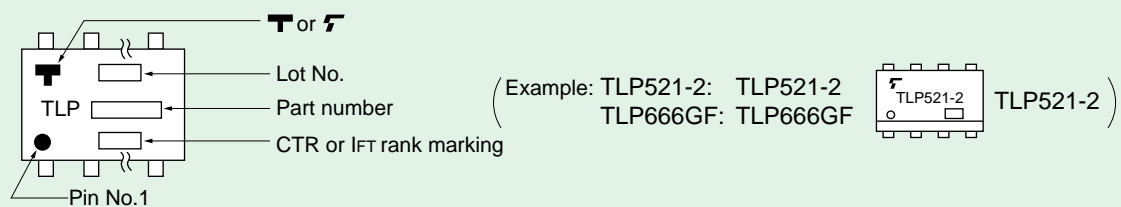

Note: To order any standard photocoupler, add rank marking in parenthesis to the standard part number.

Example: TLP521-1 (GB), TLP532 (GR)

Use Toshiba standard part number for safety standards approved application.

Example $\frac{\text{Part number}}{\text{TLP621(GR)}} \longrightarrow \frac{\text{Approved part number}}{\text{TLP621}}$

6.2 Projected Operating Life Based on LED Light Output Degradation

Toshiba photocouplers use one of three types of LEDs and a projection of the operating life is expected for each LED. The table on page 54 shows types of LED used in photocouplers and the figures on page 55 to 57 show projections of long-term light output performance and operating life. Note that those operating life data are estimates extrapolated from long-term light output degradation over a single wafer lot and are shown as reference only.

	Projected Operating Life (Ta = 40°C, If = 20 mA, failure criteria: degradation rate Δ Po < -50%)		Photocouplers
	F50% operating life	F0.1% operating life	
① GaAs LED	400,000 h	80,000 h	Mainly for phototransistor output devices and phototriac output devices
② GaAlAs(SH) LED	550,000 h	180,000 h	Mainly for photo-IC couplers
③ GaAlAs(DH) LED	330,000 h	65,000 h	Mainly for photorelays (MOSFET output), photovoltaic couplers and photo-IC couplers

F50% (cumulative failure rate 50%) operating life: Time period until projected long-term light output degradation curve of average light output change (\bar{X}) shown on pages 55 to 57 reaches the failure criteria.

F0.1% (cumulative failure rate 0.1%) operating life: Time period until projected long-term light output degradation curve of $\bar{X} - 3\sigma$ shown on pages 55 to 57 reaches the failure criteria.

The relationship between LED light output degradation and optical coupling characteristics is shown below.

(1) The relationship between LED light output degradation and current transfer ratio (CTR)/short circuit current (Isc) is 1:1.

$$\frac{\text{CTR}(t)}{\text{CTR}(o)} = \frac{\text{Po}(t)}{\text{Po}(o)}$$

(2) The relationship between a reciprocal value of LED light output degradation and IFT/IFLH/IFHL/IFH change is 1:1.

$$\frac{I_{FT}(t)}{I_{FT}(o)} = \left(\frac{\text{Po}(t)}{\text{Po}(o)} \right)^{-1}$$

● How to estimate an operating life from the graph

Example: Estimate an operating life from GaAs LED projected operating life data (failure criteria $\Delta \text{Po} < -50\%$) on page 55.

At ambient temperature of 25°C

1. Calculate absolute temperature. $25^\circ\text{C} + 273 = 298 \text{ (K)}$
2. Calculate the reciprocal value of the calculated value. $1/298 = 3.36 \times 10^{-3}$
3. Read data from the graph.

Projected operating life at Ta = 25°C, If = 50 mA (failure criteria: light output degradation $\Delta \text{Po} < -50\%$)

F50% (cumulative failure rate 50%) operating life: Approximately 60,000 h (reference value)

F0.1% (cumulative failure rate 0.1%) operating life: Approximately 12,000 h (reference value)

6 Supplementary Information

LED used in Photocouplers

Photocouplers	LED	Photocouplers	LED	Photocouplers	LED	Photocouplers	LED	Photocouplers	LED
4N25(SHORT)	①	TLP131	①	TLP330	①	TLP560 series	①	TLP750 series	②
4N25A(SHORT)	①	TLP137	①	TLP331	①	TLP561 series	①	TLP751 series	②
4N26(SHORT)	①	TLP141G	①	TLP332	①	TLP570	①	TLP759 series	②
4N27(SHORT)	①	TLP160 series	①	TLP351 series	②	TLP571	①	TLP762J series	①
4N28(SHORT)	①	TLP161 series	①	TLP371	①	TLP572	①	TLP763J series	①
4N29(SHORT)	①	TLP165J	①	TLP372	①	TLP590B	③	TLP797 series	①
4N29A(SHORT)	①	TLP166J	①	TLP373	①	TLP591B	③	TLP798G	③
4N30(SHORT)	①	TLP168J	③	TLP421 series	①	TLP592 series	①	TLP2200	②
4N31(SHORT)	①	TLP172 series	①	TLP504A	①	TLP594 series	①	TLP2530	②
4N32(SHORT)	①	TLP174G	①	TLP511GA	①	TLP597 series	①	TLP2531	②
4N32A(SHORT)	①	TLP176 series	①	TLP512	②	TLP598 series	③	TLP2601	②
4N33(SHORT)	①	TLP180	①	TLP513	②	TLP599 series	①	TLP260J	①
4N35(SHORT)	①	TLP181	①	TLP521-1	①	TLP611J	①	TLP2630	②
4N36(SHORT)	①	TLP190B	③	TLP521-2	①	TLP620 series	①	TLP2631	②
4N37(SHORT)	①	TLP191B	③	TLP521-4	①	TLP621 series	①	TLP3022(S) series	①
4N38(SHORT)	①	TLP192 series	①	TLP523 series	①	TLP624 series	①	TLP3042(S) series	①
4N38A(SHORT)	①	TLP197 series	①	TLP525G series	①	TLP626 series	①	TLP3063(S) series	③
6N135	②	TLP200D	①	TLP531	①	TLP627 series	①	TLP31xx series	①
6N136	②	TLP202 series	①	TLP532	①	TLP628 series	①	TLP3502	①
6N137	②	TLP206 series	①	TLP541G	①	TLP629 series	①	TLP3502A	①
6N138	②	TLP222 series	①	TLP542G	①	TLP630	①	TLP3503	①
6N139	②	TLP224G series	①	TLP543J	①	TLP631	①	TLP3506	①
TLP112	②	TLP225A	①	TLP545J	①	TLP632	①	TLP3507	①
TLP112A	③	TLP227 series	①	TLP550	②	TLP641 series	①	TLP3520	①
TLP113	②	TLP250 series	②	TLP551	②	TLP651	②	TLP3520A	①
TLP114A	③	TLP251 series	②	TLP552	②	TLP722	②	TLP3521	①
TLP115	②	TLP270 series	①	TLP553	②	TLP731	①	TLP3526	①
TLP115A	③	TLP280 series	①	TLP554	②	TLP732	①	TLP3527	①
TLP124	①	TLP281 series	①	TLP555	②	TLP733 series	①	TLP3530	①
TLP126	①	TLP283 series	①	TLP557	②	TLP734 series	①	TLP3540	①
TLP127	①	TLP296G	①	TLP558	②	TLP741 series	①	TLP4xxx series	①
TLP130	①	TLP320 series	①	TLP559	②	TLP747 series	①		

① GaAs LED ② GaAlAs (SH) LED ③ GaAlAs (DH) LED

GaAs LED Projected Light Output Degradation Data

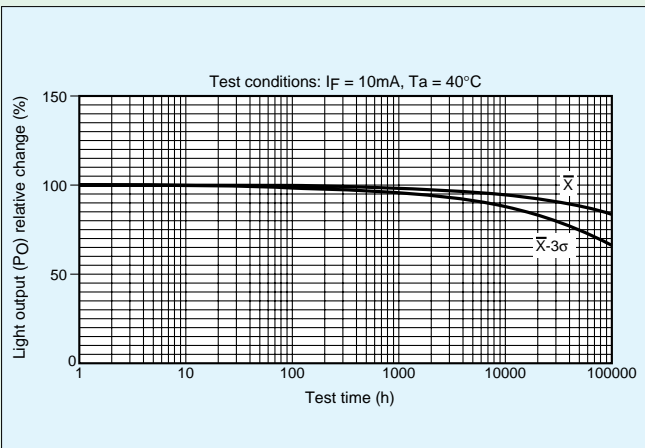
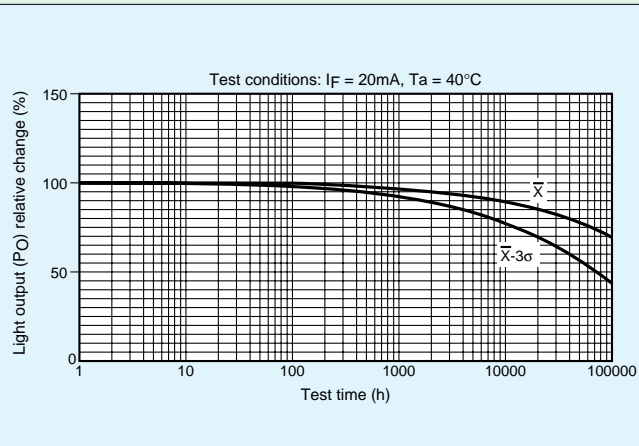
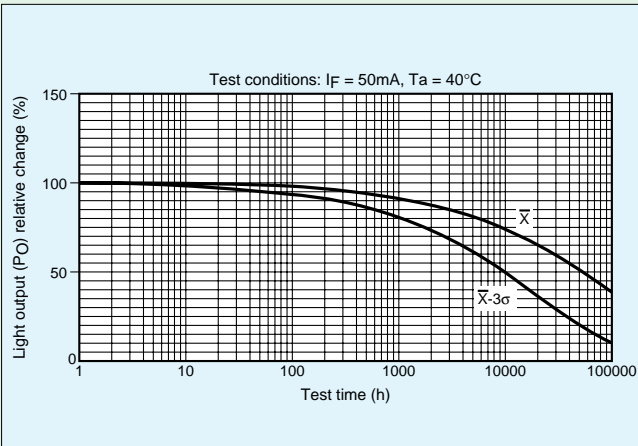

GaAs LED Projected Operating Life Data

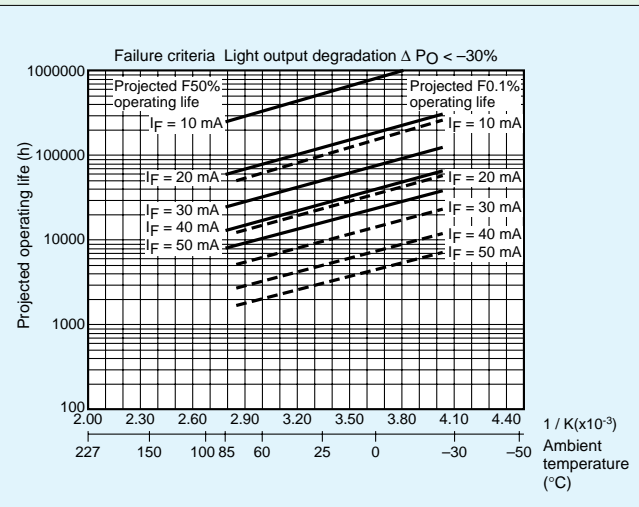
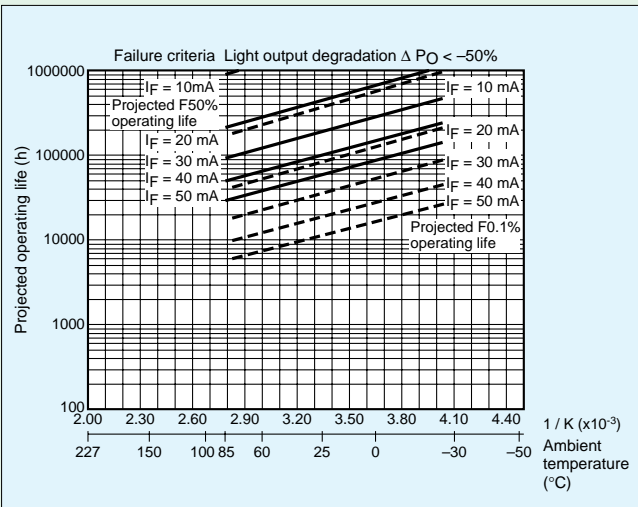

The above operating life data are estimates extrapolated from long-term light output degradation over a single wafer lot and are shown as reference only. The operating conditions exceeding the maximum ratings are not guaranteed.

6 Supplementary Information

GaAlAs (SH) LED Projected Light Output Degradation Data

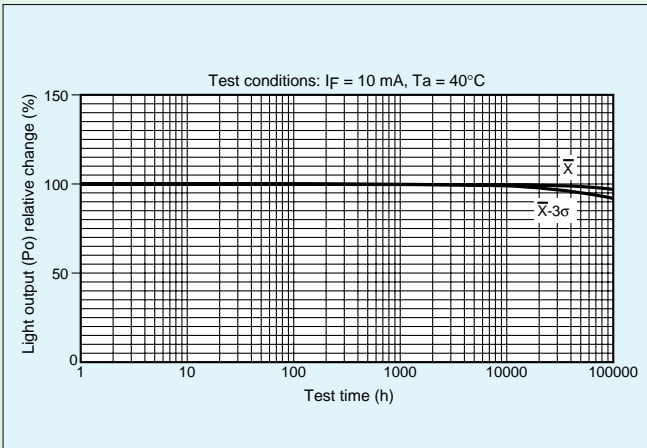
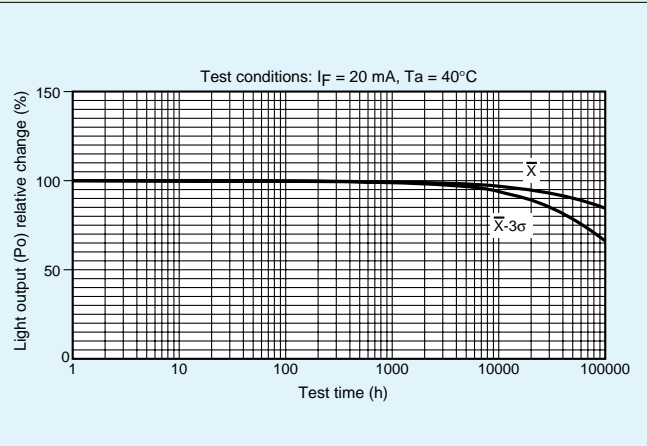
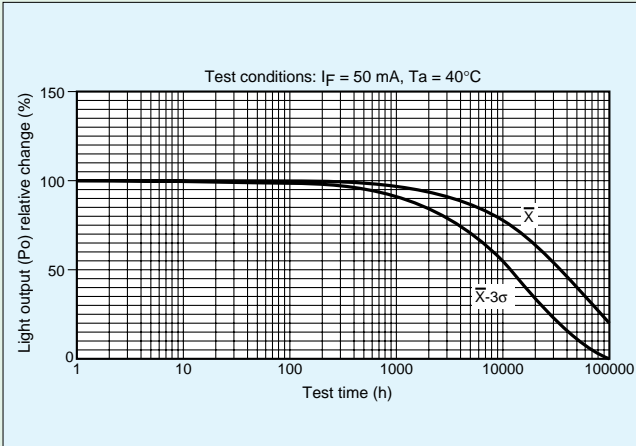

GaAlAs (SH) LED Projected Operating Life Data

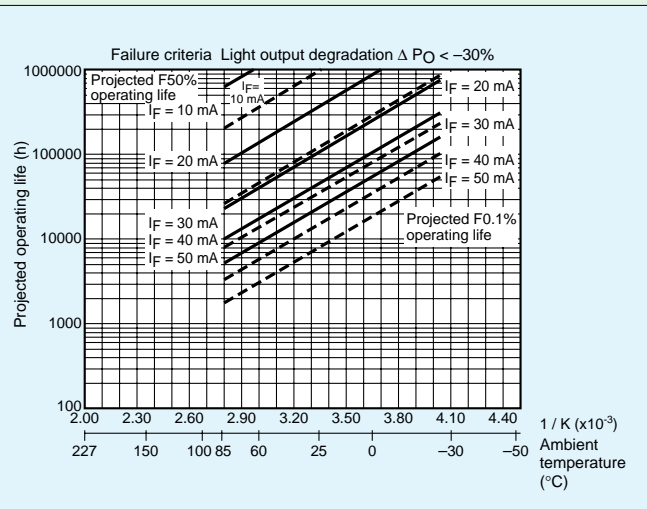
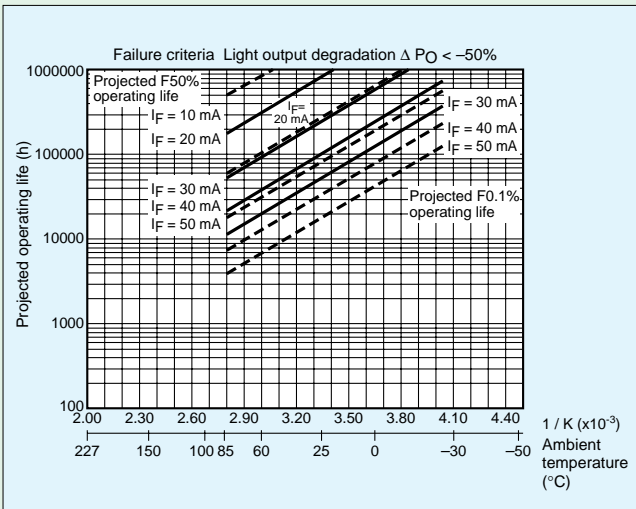

The above operating life data are estimates extrapolated from long-term light output degradation over a single wafer lot and are shown as reference only. The operating conditions exceeding the maximum ratings are not guaranteed.

GaAs (DH) LED Projected Light Output Degradation Data

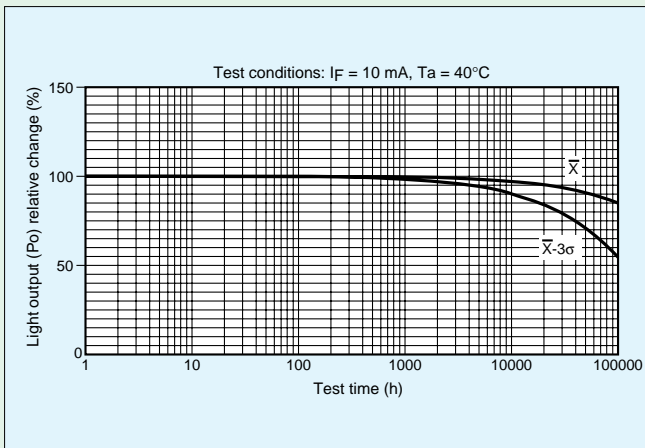
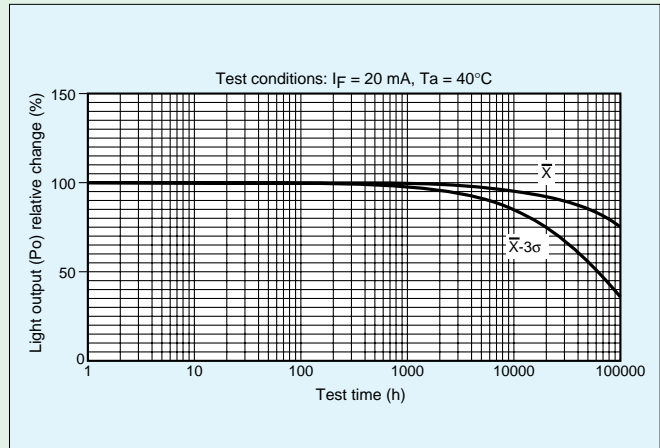
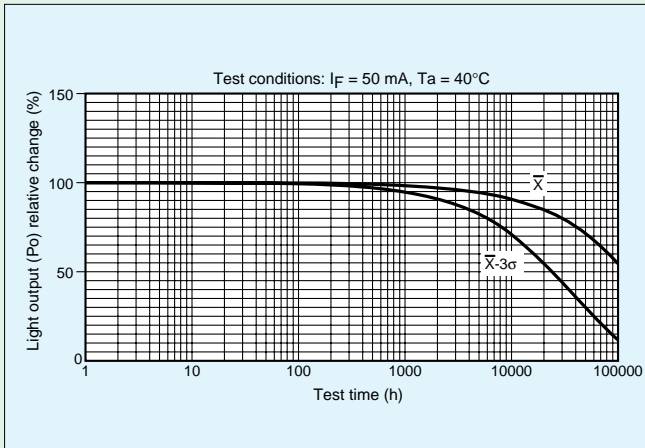

GaAs (DH) LED Projected Operating Life Data

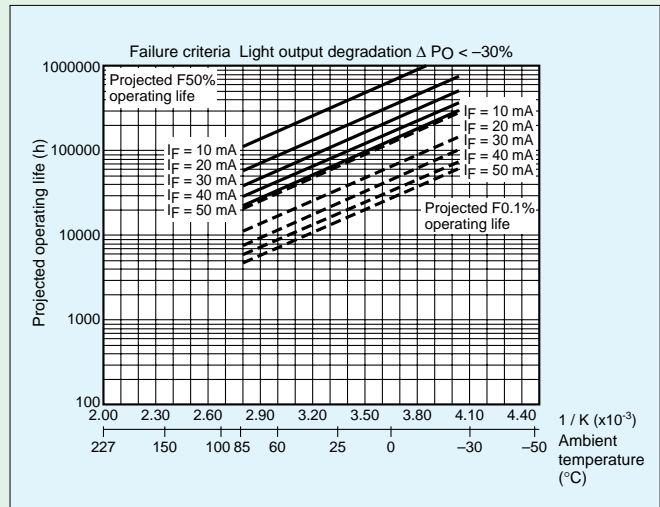
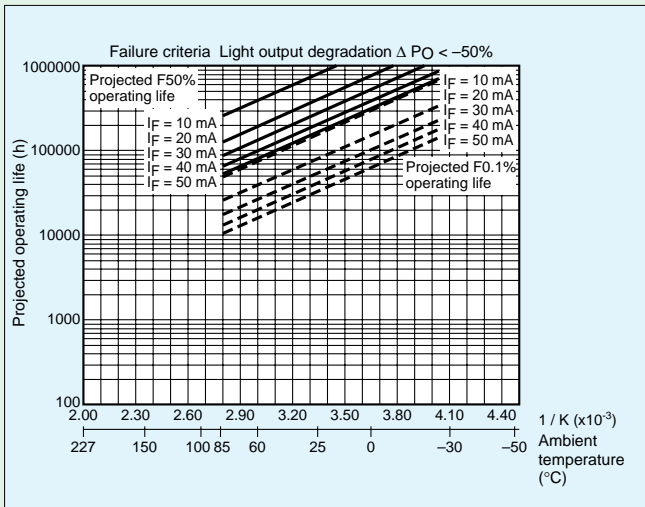





The above operating life data are estimates extrapolated from long-term light output degradation over a single wafer lot and are shown as reference only. The operating conditions exceeding the maximum ratings are not guaranteed.

7 Safety Standard Approved Photocouplers

Toshiba's extensive line of photocouplers is approved by UL (USA), VDE (Germany), BSI (England), SEMKO (Sweden). These devices offer a wide selection of output (transistor, thyristor and triac) and are well matched for a variety of applications including switching power supplies and solid state relays. Note that when a VDE0884-approved device is required, please specify option D4.

7.1 Safety Standard Approvals for Photocouplers

(As of January 2004)

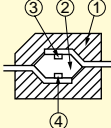
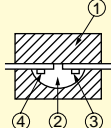
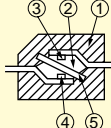
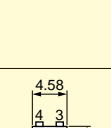
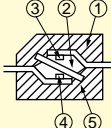
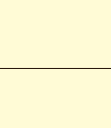
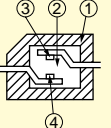
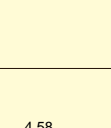
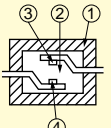
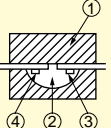
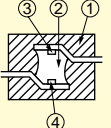
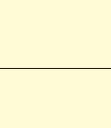
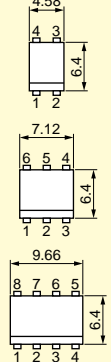
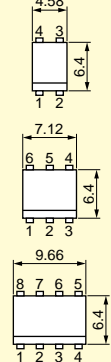
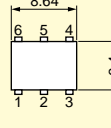
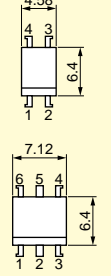
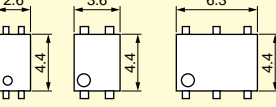
Safety Standard		UL	VDE	BSI	SEMI	Other	
Safety Standard		TLP421 TLP521-1 TLP531/532 TLP541G/545J TLP550/551 TLP560G/561G	TLP620/-2/-4 TLP621/-2/-4 TLP750/751 TLP631/632 TLP641G/641J TLP651 TLP360J TLP361J	TLP3022F(S) TLP3052F(S) TLP3042F(S) TLP3062F(S)	TLP733/734 TLP747G TLP747J TLP762J TLP763J	TLP121 TLP131 TLP112A TLP115A TLP180 TLP181 TLP280 TLP281	TLP127 TLP160G TLP141G TLP190B TLP197G TLP176G TLP206G
		TLP227G TLP227G-2 TLP250 TLP251 TLP597G	TLP620/-2/-4 TLP621/-2/-4 TLP627/-2/-4 TLP750/751/759	TLP3022F(S) TLP3052F(S) TLP3042F(S) TLP3062F(S) TLP3064F(S) TLP798G	TLP733/734 TLP747G TLP747J TLP762J	TLP165J TLP166J TLP181 TLP280 TLP281	TLP127 TLP176G TLP197G TLP206G
		TLP227G TLP227G-2 TLP421 TLP597G	TLP620/-2/-4 TLP621/-2/-4 TLP624/-2/-4 TLP626/-2/-4 TLP627/-2/-4 TLP750/751	TLP798G	TLP733/734 TLP747G TLP747J TLP762J TLP763J	TLP180 TLP181 TLP280 TLP281	TLP127 TLP176G TLP197G TLP206G
		TLP222G TLP222G-2 TLP227G TLP227G-2 TLP421 TLP597G	TLP620/-2 TLP621/-2 TLP627/-2	TLP798G	TLP733/734 TLP747G TLP747J TLP762J TLP763J	TLP180 TLP181 TLP280 TLP281	TLP176G TLP197G TLP206G
Internal Construction (Cross Section)	<ul style="list-style-type: none"> ① Body ② Window ③ Detector ④ LED ⑤ Film 	 TLP421 	 	 	 	 TLP181/TLP281 	 
		Package Dimensions (Unit: mm)					

7.2 Device Type, Construction Mechanical Ratings and Safety Standard Approvals

Device Type	4-pin multi-channel photocoupler	TLP181**/ TLP180	-	-	TLP280/TLP281		-	-	
	Transistor Output	-	TLP131	-	-	-	-	-	
	Thyristor Output	-	-	-	-	-	TLP141G	-	
	Triac Output	-	-	TLP165J/ TLP166J	-	-	TLP160J/ TLP161J	-	
	IC Output	-	TLP114A	-	-	-	-	-	
	Photorelay	-	-	-	-	-	-	TLP176G TLP206G	
Construction Mechanical Ratings (min)	Package	MFSOP			SOP		MFSOP	2.54SOP	
	Isolation Creepage Path (mm)	4.0			4.0		4.0		
	Isolation Clearance (mm)	4.0			4.0		4.0		
	Isolation Thickness (mm)	0.4	-		0.4	-		-	
	Internal Creepage Path (mm)	-			-		-		
	Isolation Voltage (kVrms)	3.75		2.5		2.5		1.5	
	Internal Construction (Cross Section)	①Body ②Window ③Detector ④LED ⑤Film							
<ul style="list-style-type: none"> ● Safety Standard Approved ○ Reinforced insulation (SELV) ○ Basic insulation (ELV) 		UL1577 (File No. E67349)	Parts Specifications	●		●		●	
		Double Protection	-		-		-		-
		DIN VDE 0884/08.87	Parts Specifications	●** (Note 2)	○	● (Note 2)	●* (Note 2)	○	○
		DIN IEC65/ VDE 0860/08.81	Home Appliances	○		○		○	
		DIN IEC380/ VDE 0806/08.81	Office Equipment	○		○		○	
		DIN IEC435/ VDE 0805/08.79	Data processing Equipment	○		○		○	
		DIN57 804 VDE 0804/01.83	Data processing Equipment	○		○		○	
		DIN57 700T1/ VDE 0700T1/2.81	Home Appliances	○		○		○	
		DIN IEC601T1/ VDE 0750T1/05.82	Medical Equipment	○		○		○	
		BS EN60065: 1994	Home Appliances	●	○	●	○	●	
		BS EN60950: 1992	Office Equipment	●	○	●	○	●	
		BS6301: 1989	Telecommunications Networks	●	○	●	○	●	
		SEMKO SS-EN60950	Office Equipment	●	-	●	-	●	

Note 1: The VDE0884 will be updated to the EN60747-5-2 in January 2004. For details, please contact your nearest Toshiba sales office.

Note 2: VDE0884 standards for MFSOP and SOP photocouplers are different from those of standard DIP photocouplers because MFSOP and SOP are compact and small packages.

*: Only applied to the TLP281

** : Only applied to the TLP181

7 Safety Standard Approved Photocouplers

7.2 Device Type, Construction Mechanical Ratings and Safety Standard Approvals

Device Type		4-pin multi-channel photocoupler	TLP624/626	TLP621*/620/627	-	-	-	-	TLP521-1	TLP421
		Transistor Output	-	-	-	TLP733/734	-	-	-	-
Thyristor Output	-	-	-	TLP747G/TLP747J	-	-	-	-	-	
Triac Output	-	-	-	-	TLP762J/TLP763J	-	-	TLP3022F(S) TLP3052F(S) TLP3042F(S) TLP3062F(S)	-	-
IC Output	TLP750/TLP751	-	-	-	-	-	-	-	-	-
Photorelay	-	-	-	-	-	-	-	-	-	-
Construction Mechanical Ratings (min)		Package	DIP		DIP		DIP		DIP	DIP
		Isolation Creepage Path (mm)	6.4	7.0	7.0		7.0		6.4	7.0
		Isolation Clearance (mm)	6.4	8.0 (Note 3)	8.0 (Note 3)		8.0 (Note 3)		6.4	8.0 (Note 3)
		Isolation Thickness (mm)	0.4	0.4	0.4		0.5		-	0.4
		Internal Creepage Path (mm)	-	-	4.0		-		-	-
		Isolation Voltage (kVrms)	5.0	5.0	4.0		4.0	5.0	2.5	5.0
		Internal Construction (Cross Section)	①Body ②Window ③Detector ④LED ⑤Film							
Safety Standard Approved	UL1577 (File No. E67349)	Parts Specifications	●	●	●	●	●	●	●	
		Double Protection	-	●*	-	-	-	-	-	
	Reinforced insulation (SELV)	DIN VDE 0884/08.87	Parts Specifications	○	● (Note 2)	● (Note 2)	● (Note 2)	● (Note 2)	-	● (Note 2)
			DIN IEC65/VDE 0860/08.81	Home Appliances	○	○	○	○	○	○
			DIN IEC380/VDE 0806/08.81	Office Equipment	○	○	○ (Note 3)	○	○	○
			DIN IEC435/VDE 0805/08.79	Data processing Equipment	○	○	○ (Note 3)	○	○	○
			DIN57 804 VDE 0804/01.83	Data processing Equipment	○	○	○	○	○	○
			DIN57 700T1/VDE 0700T1/2.81	Home Appliances	○	○	○	○	○	○
	Basic insulation (ELV)	DIN IEC601T1/VDE 0750T1/05.82	Medical Equipment	○	○	○ (Note 3)	○	○	○	○
			BSI	BS EN60065: 1994	Home Appliances	●	●	●	●	○
BS EN60950: 1992				Office Equipment	●	●	●	●	○	●
BS6301: 1989				Telecommunications Networks	●	●	●	●	○	●
SEMKO	SS-EN60950	Office Equipment	● (Note 4)	●	●	-	●	-	●	

Note 1: The VDE0884 will be updated to the EN60747-5-2 in January 2004. For details, please contact your nearest Toshiba sales office.

Note 2: VDE0884 standards for MFSOP and SOP photocouplers are different from those of standard DIP photocouplers because MFSOP and SOP are compact and small packages.

Note 3: 8.0 for (LF2) or F type. Note 3: VDE0884-approved with option (D4).

Note 4: The TLP621 / 620 / 627 are approved. TOSHIBA recommends the TLP421 / 621 rather than the TLP721 for your new designing.

*: Only applied to the TLP621.

8 Photocoupler Application Circuit Example

8.1 Digital Interface Applications

High Speed

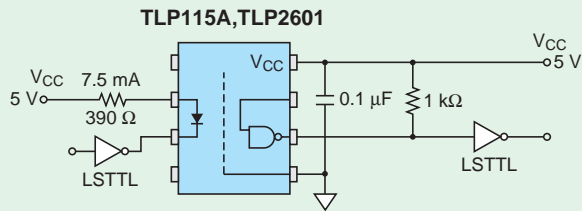

By using the high-speed TLP2601 device, (the equivalent MFC⁽¹⁾ version is the TLP115A) high-speed data transmission is possible up to approximately 5 MHz.

f(typ.): 5 Mbit/s (Duty cycle \cong 1/2)

Low Input Current Drive

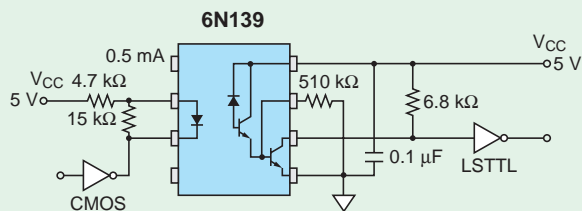

Use of the high-CTR (current transfer ratio) 6N139 enables operation by low input current (0.5 mA), and direct driving with a CMOS.

f(typ.): 50 kbit/s (Duty cycle \cong 1/2)

Pull-up Resistor Replacement

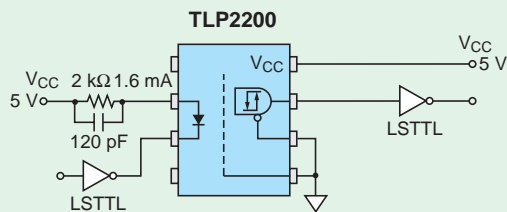

When the 3-state-output TLP2200 is used, the next-step logic gate can be actuated without using a pull-up resistor.

f(typ.): 1 Mbit/s (Duty cycle \cong 1/2)

High VCC Tolerance

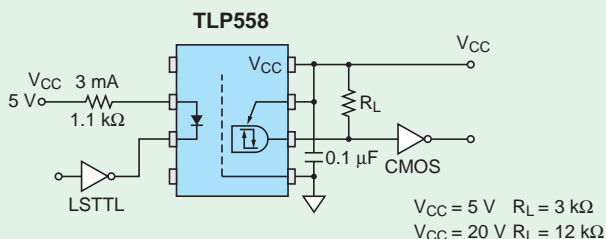

By using the TLP558 which accepts a wide range of V_{CC} (up to 20 V), the CMOS logic gates and other components can be operated with high V_{CC} .

f(typ.): 1 Mbit/s (Duty cycle \cong 1/2)

8 Photocoupler Application Circuit Example

8.2 Inverter and AC / DC Servo Applications

[Photo-IC coupler, high-speed base/gate drive circuit application]

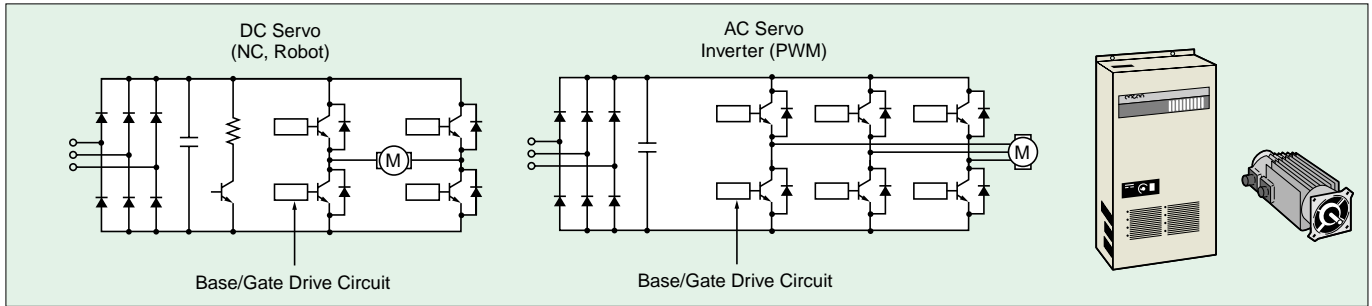
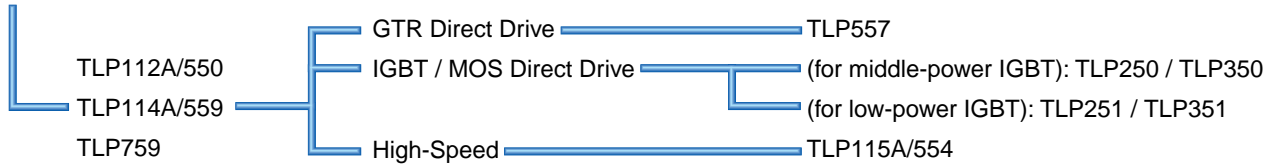

15-A Class GTR (Giant Transistor) Module Base Drive

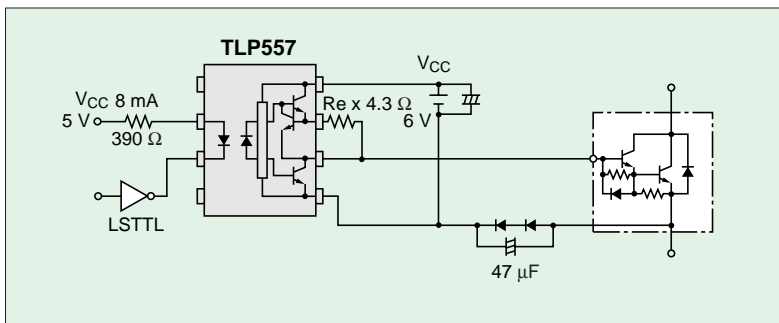

The TLP557 drives a GTR base directly. An external resistor R_{ex} is connected between pins 6 and 7. This resistor causes the drive base current to become constant and stabilizes the GTR drive.

100-A Class GTR Module Base Drive

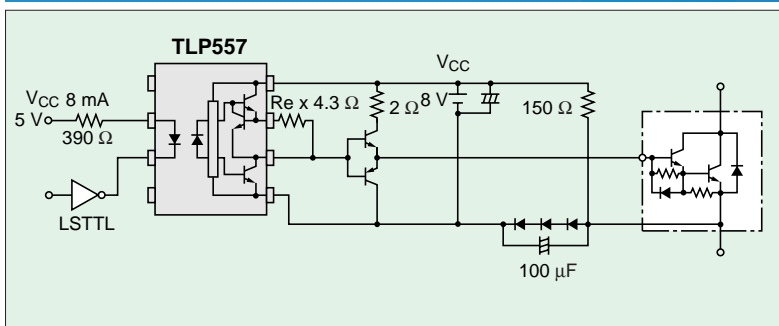

The TLP557 photo-IC coupler and two booster transistors can drive a high-power GTR.

15-A Class IGBT (Insulated Gate Bipolar Transistor) Module Gate Drive

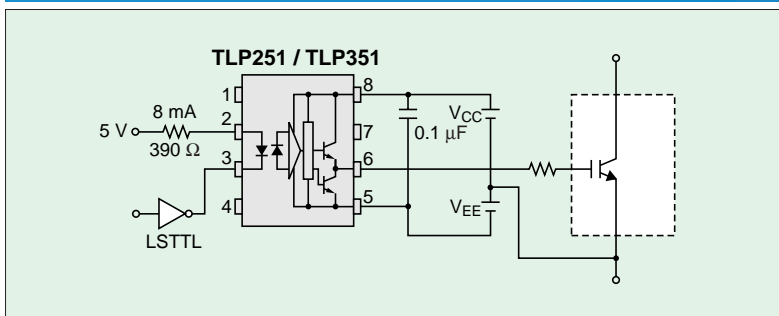

The TLP251 / 351 high-speed photo-IC photocoupler can drive a low power IGBT directly.

50-A Class IGBT Module Gate Drive

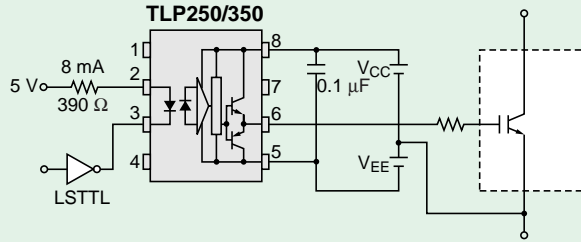

The TLP250 / 350 can drive a medium power IGBT directly.

400-A Class IGBT Module Gate Drive

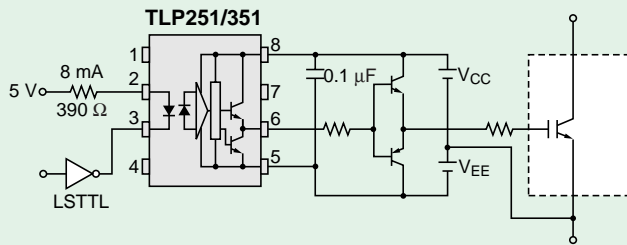

The TLP251 / 351 high-speed photo-IC photocoupler and two booster transistors can drive a high power IGBT.

IGBT Module Gate Drive Using (IGM) Selection

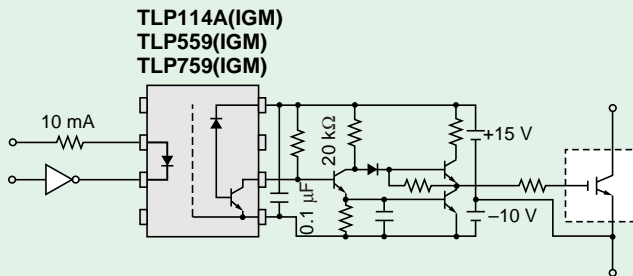

The (IGM) selection is suitable to drive an IPM (Intelligent Power Module). The device has a guaranteed propagation delay difference $t_{PLH} - t_{PHL}$ and provides a high common transient immunity.

(IGM) Selection

Part Number	Package Type	BVs (Vrms)	Vo/Vcc	CTR	$ t_{PLH} - t_{PHL} $	CMH	CML
TLP114A (IGM)	MFSOP6	3750	20 V / 30 V max	25 % min 75 % max @ If = 10 mA Vcc = 4.5 V Vo = 0.4 V	0.7 μs max @ If = 10 mA RL = 20 kΩ	10000 V / μs min @ If = 0 mA RL = 20 kΩ VCM = 1500 Vp-p	- 10000 V / μs min @ If = 10 mA RL = 20 kΩ VCM = 1500 Vp-p
TLP559 (IGM)	DIP8	2500					
TLP759 (IGM)	DIP8	5000					

8 Photocoupler Application Circuit Example

8.3 TV and Audio Applications

Application for "MIDI" Interface for Electronic Musical Instrument

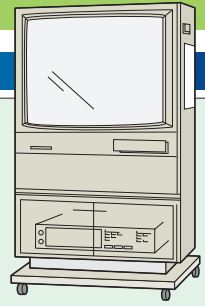
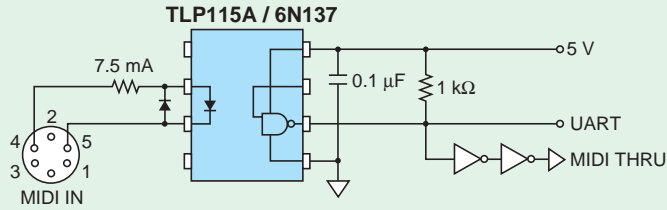

Application for Compact Disc Player

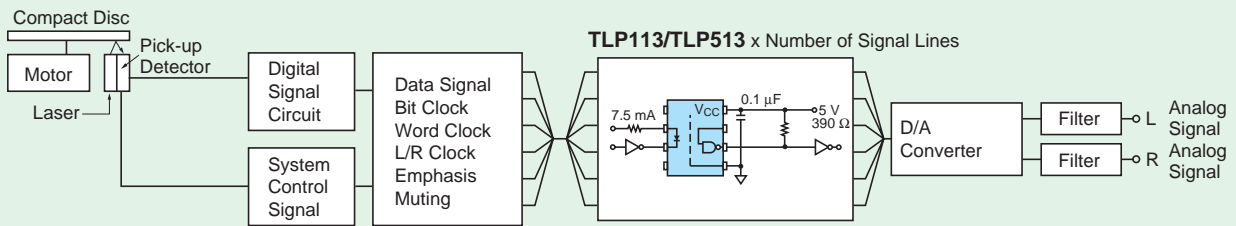

Application for TV/AV Terminal Isolation

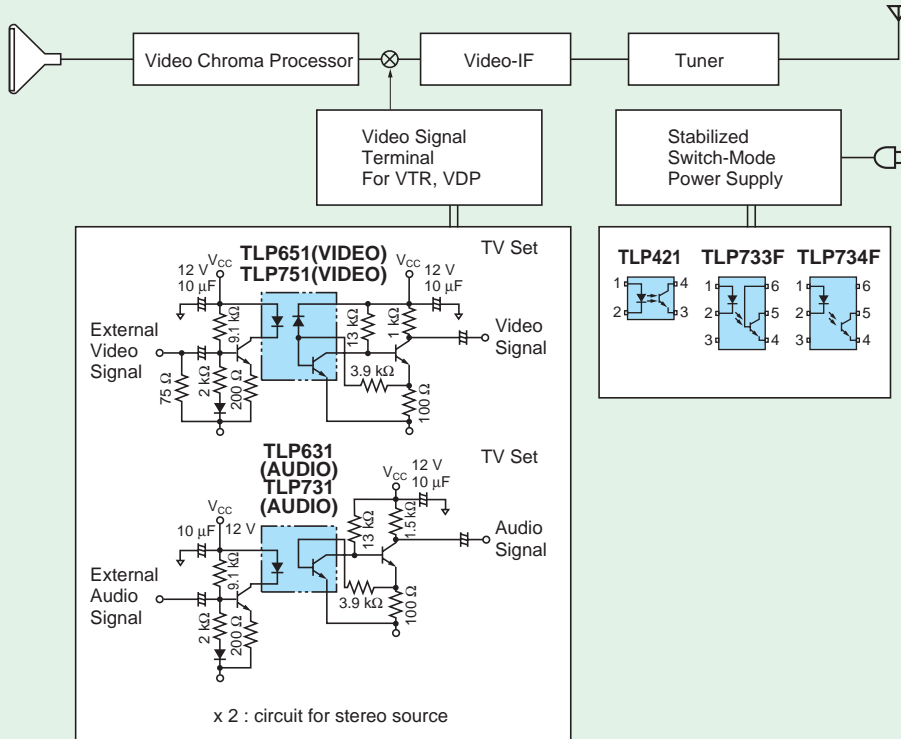

Part Number	Isolation Voltage	Band Width	Voltage Gain
TLP651 (VIDEO)	5000 Vrms	> 4.5 MHz	0.5 to 2
TLP751 (VIDEO)	5000 Vrms		0.4 to 1.8
TLP631 (AUDIO)	5000 Vrms	> 100 kHz	0.7 to 2
TLP731 (AUDIO)	4000 Vrms		

8.4 Home Appliance Applications

Oven/Grill Set Application

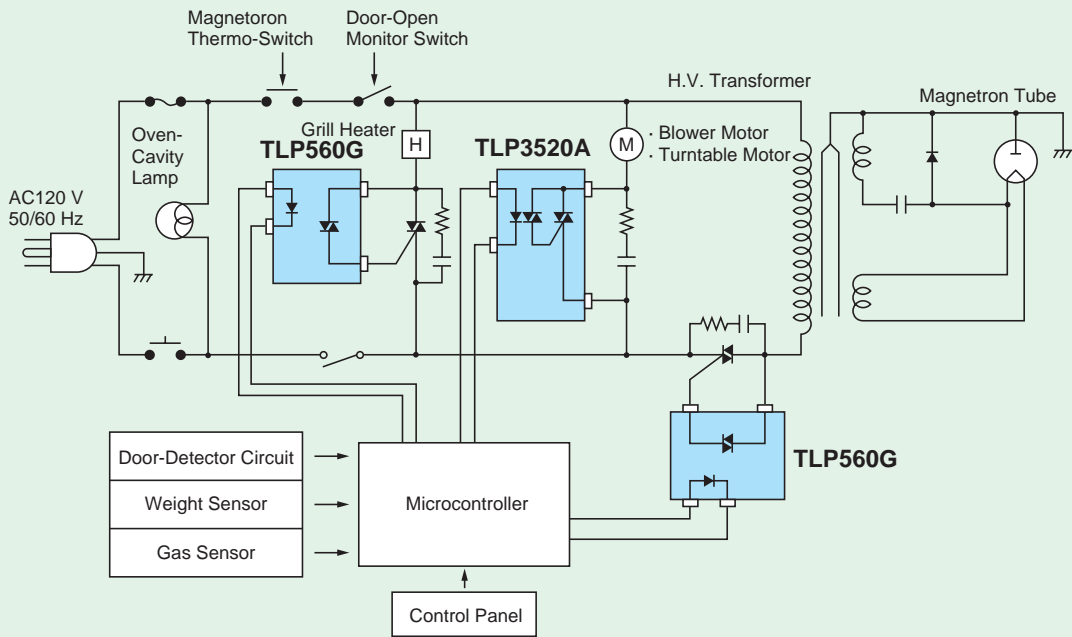

Block Diagram for Refrigerator Application

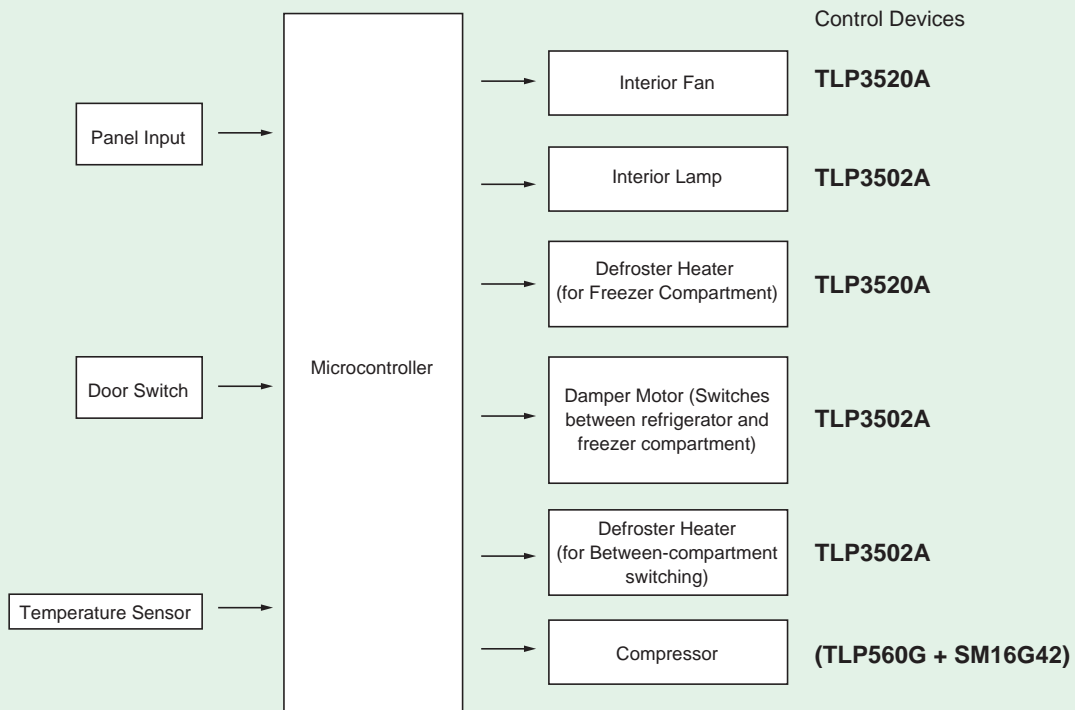

8 Photocoupler Application Circuit Example

Automatic Washing Machine Application

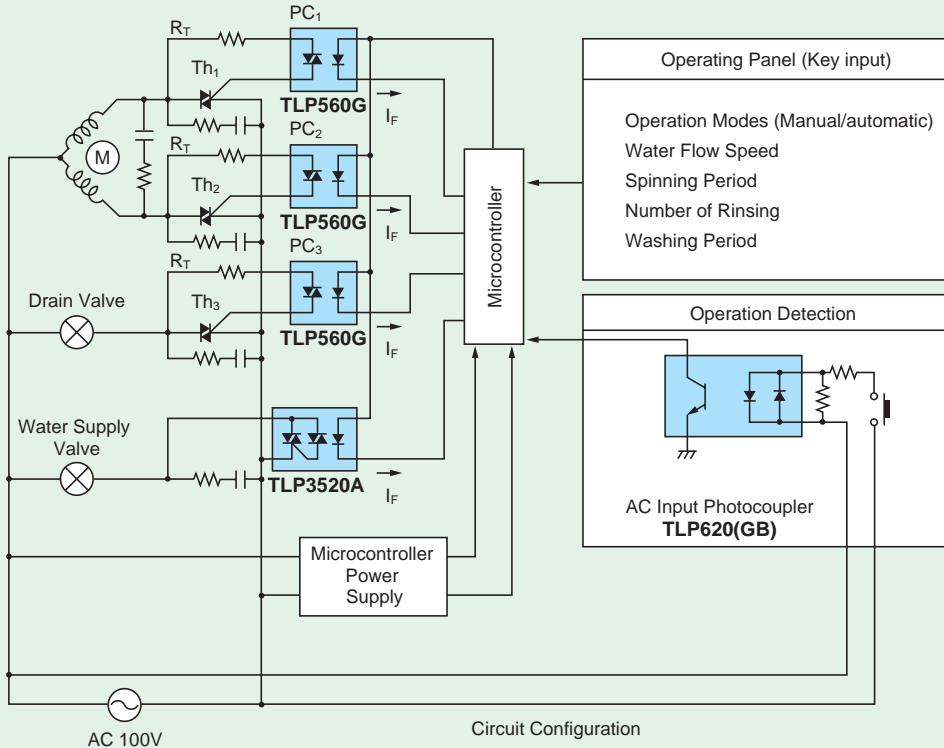

Application for Fan Heater

(a) Block Diagram

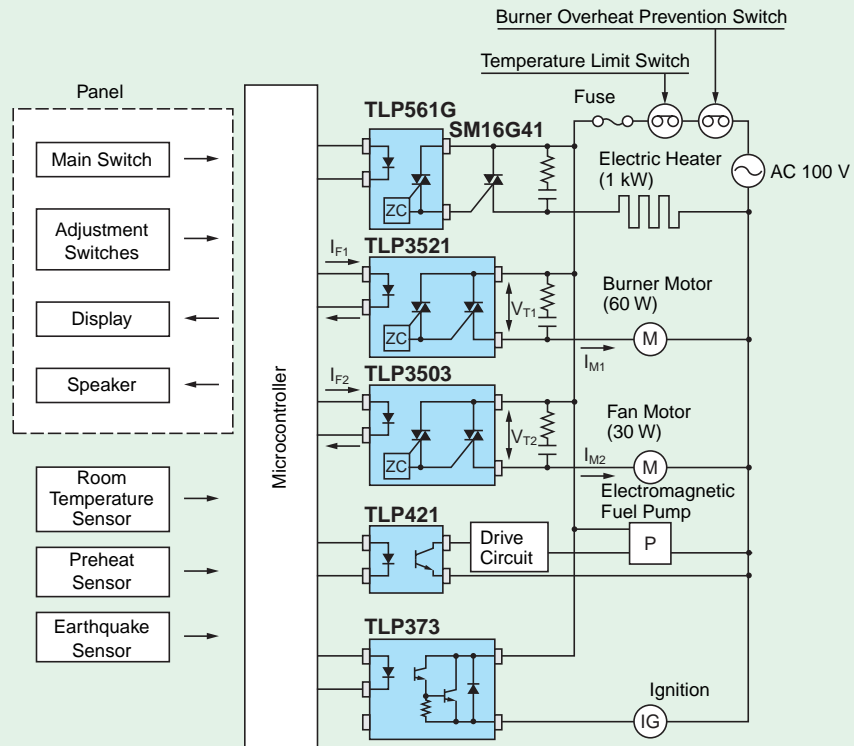

(b) Waveform Examples

1. Example of Operating Waveform for Burner Motor

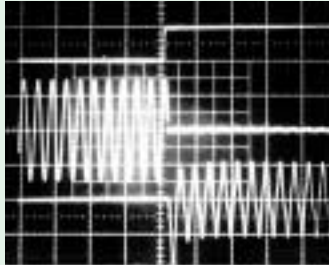

Trigger Point

Top:	I_{F1}	20 mA/div
Medium:	V_{T1}	100 V/div
Bottom:	I_{M1}	1 A/div
Horizontal:	time	50 ms/div

2. Example of Operating Waveform for Fan Motor

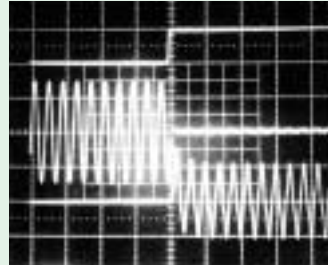

Trigger Point

Top:	I_{F2}	20 mA/div
Medium:	V_{T2}	100 V/div
Bottom:	I_{M2}	0.5 A/div
Horizontal:	time	50 ms/div

Application for Inverter Air Conditioner

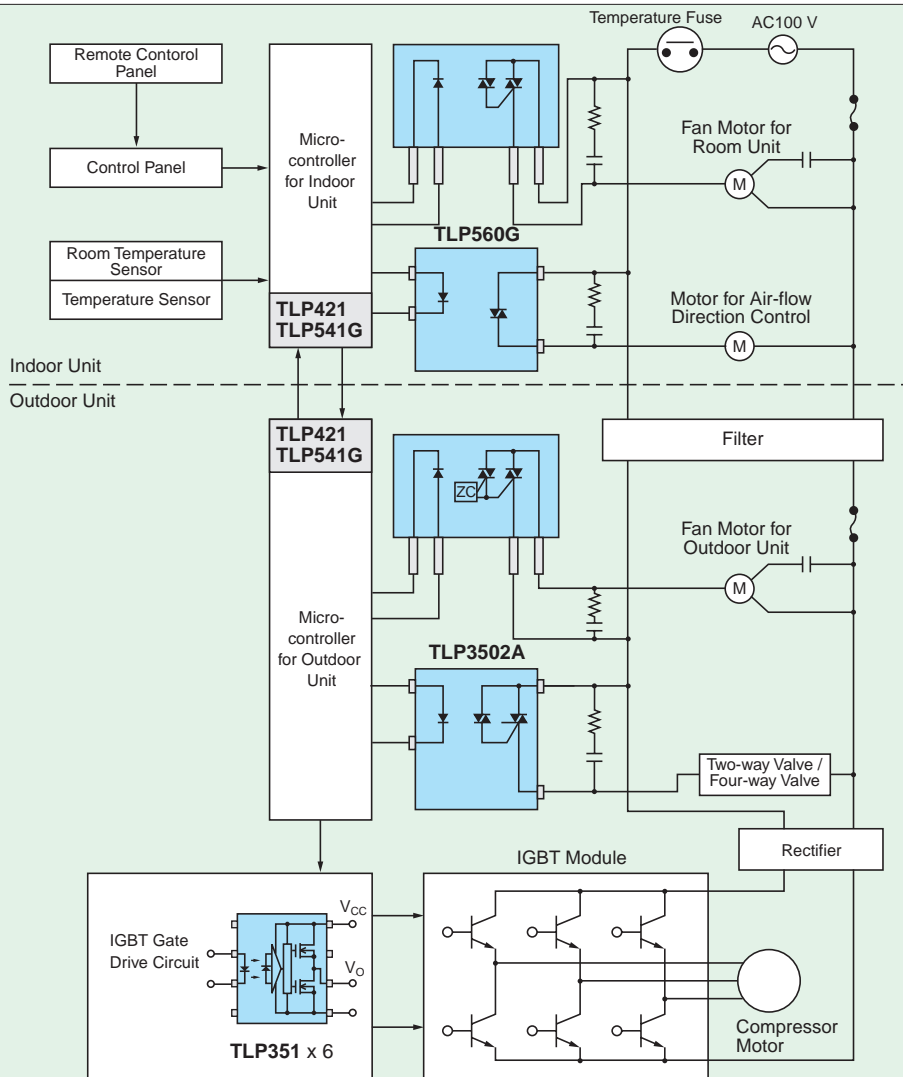

8 Photocoupler Application Circuit Example

8.5 Programmable Controller Applications

DC Output for Sequencer

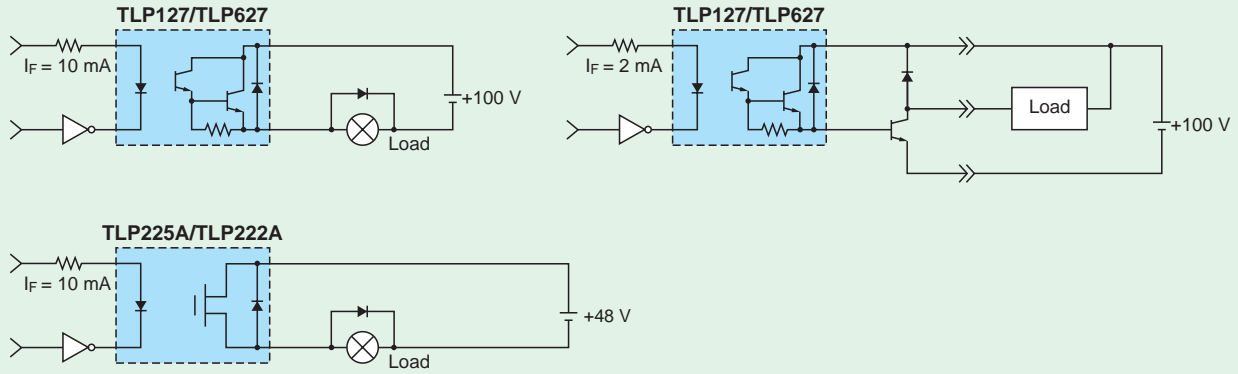

AC Input for Sequencer

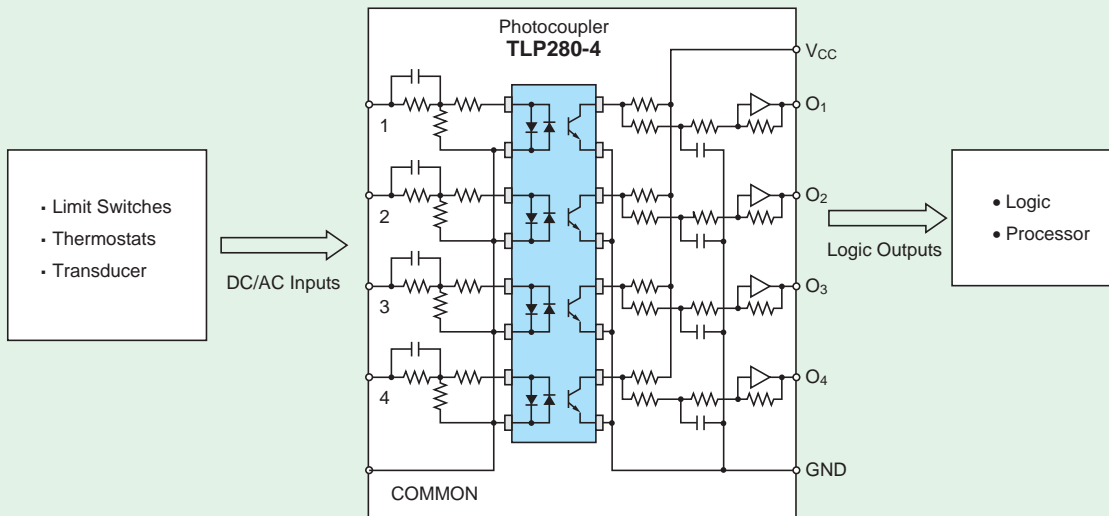

120-/240-V AC Output for Sequencer and SSR

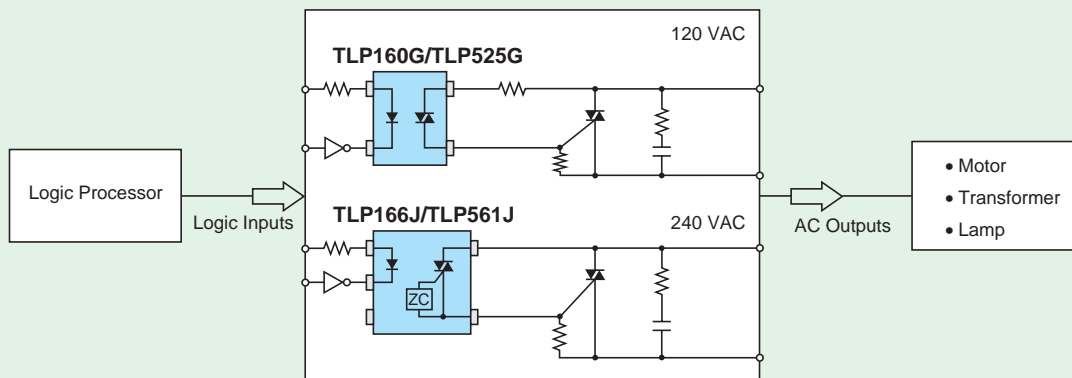

8.6 SSR and Power Control Circuit Applications

Zero-Crossing Phototriac Output Device Application: TLP561G/TLP561J and Mini-flat TLP161G/TLP166J

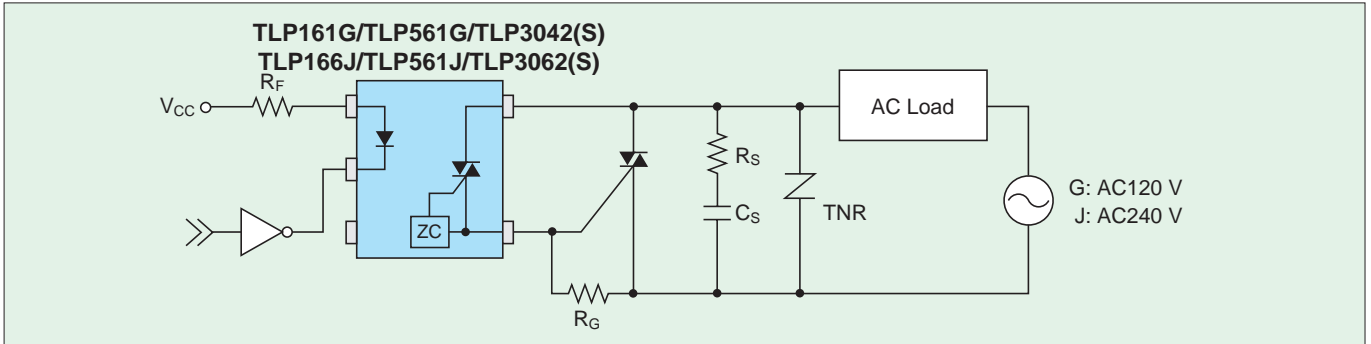

Lamp Load (1-A tungsten lamp)



Waveforms { Top: I_F 20 mA/div
Medium: V_T 100 V/div
Bottom: I_T 5 A/div

L load (2.5-A pure inductive load)



Recommended conditions { I_F = 20 mA
R_G = 47 Ω
R_S = 47 Ω, C_S = 0.033 μF

Non-Zero Crossing Phototriac Output Device Application: TLP560G/TLP560J and Mini-flat TLP160G/TLP165J

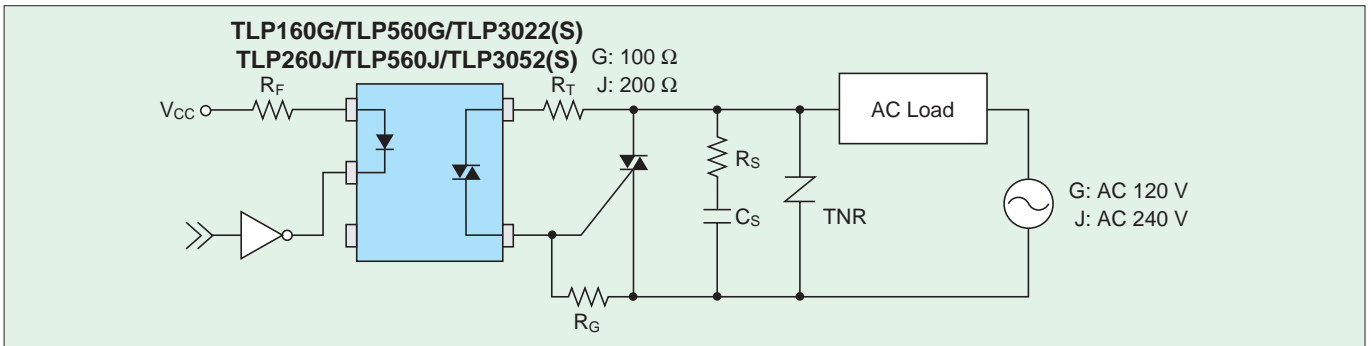

Lamp Load (1-A tungsten lamp)



Waveforms { Top: I_F 20 mA/div
Medium: V_T 100 V/div
Bottom: I_T 5 A/div

L load (2.5-A pure inductive load)



Recommended conditions { I_F = 20 mA
R_T = 100 Ω/200 Ω
R_G = 47 Ω
R_S = 47 Ω, C_S = 0.033 μF

8 Photocoupler Application Circuit Example

8.7 Switching Power Supply Circuit Application

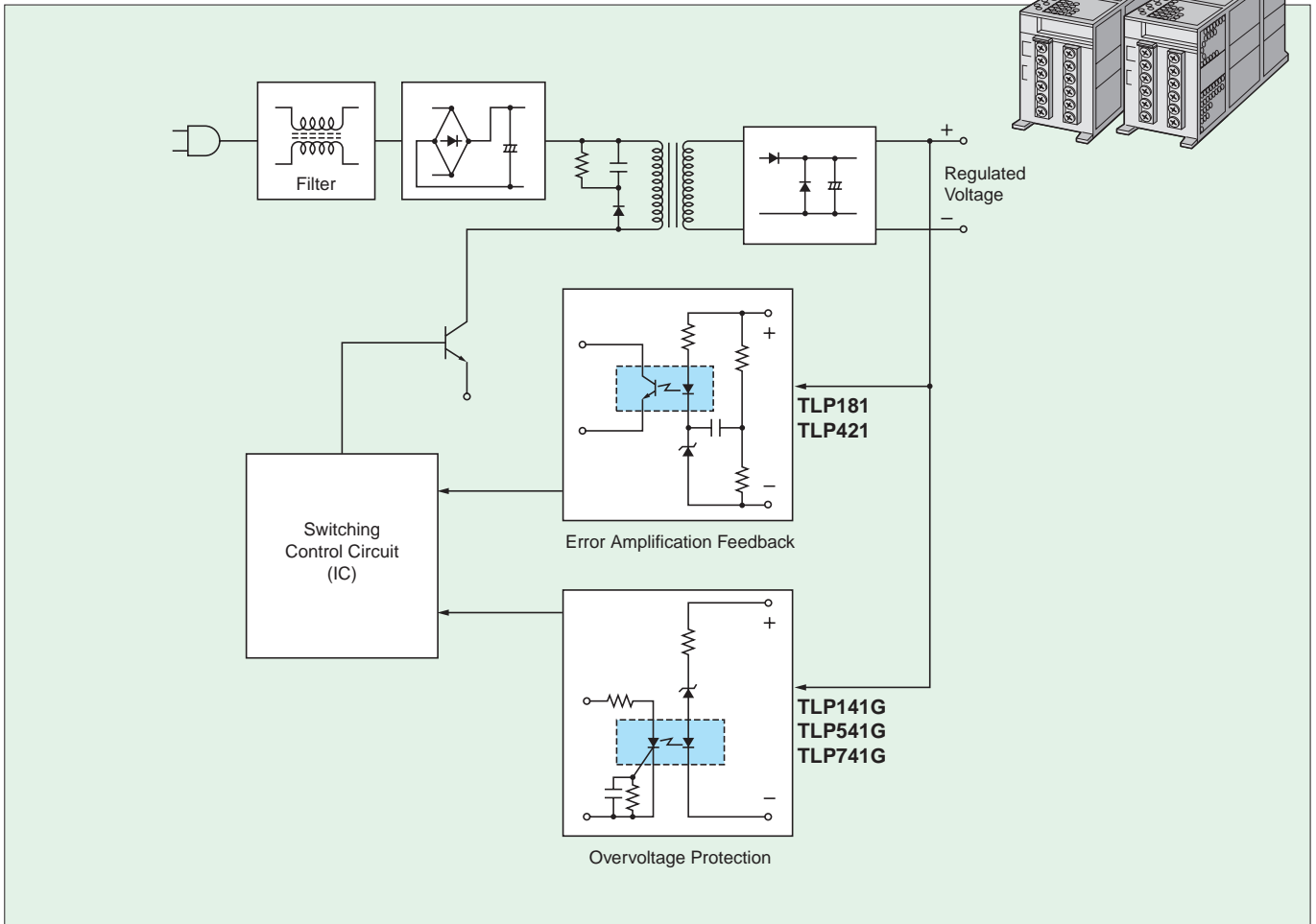

● Transistor Output (○: Approved, △: Design which meets safety standards, as of March 2003)

Part Number	Package Type	Isolation Voltage	Safety Standard Approvals				CTR (Ic / If) Rank (%)		
			UL 1577	BSI 7002 (EN60950)	VDE 0884 (Note 1)	Nordic SEMKO		Min	Max
TLP181	Min flat	3750 Vrms	○	○	△(Note 2)	○	No Rank	50	600
TLP421	DIP4	5000 Vrms	○*	○	○	○	(GB) Rank	100	600
							(Y) Rank	50	150
							(GR) Rank	100	300
							(BL) Rank	200	600
							(GRL) Rank	100	200
TLP750 (high-speed)	DIP8	5000 Vrms	○	○	○	○	(GRH) Rank	150	300
							(O) Rank	19	—
							No Rank	10	—

Note 2: VDE0884 standards for mini-flat photocoupler are different from those for standard DIP photocouplers because mini-flat package is compact and small.

● Thyristor Output

Part Number	Package Type	Isolation Voltage	Safety Standard Approvals				IFT(mA)	VDRM(V)
			UL 1577	BSI 7002 (EN60950)	VDE 0884 (Note 1)	Nordic SEMKO		
TLP141G	Min flat	2500 Vrms	○				10	400
TLP541G	DIP6		○				7	
TLP741G		4000 Vrms	○	○	○	○	10	

Note 1: VDE0884-approved with option (D4)

8.8 Push-Button Telephone Application

A variety of photocouplers are used to isolate between telephone lines (L1 and L2) and CPU.

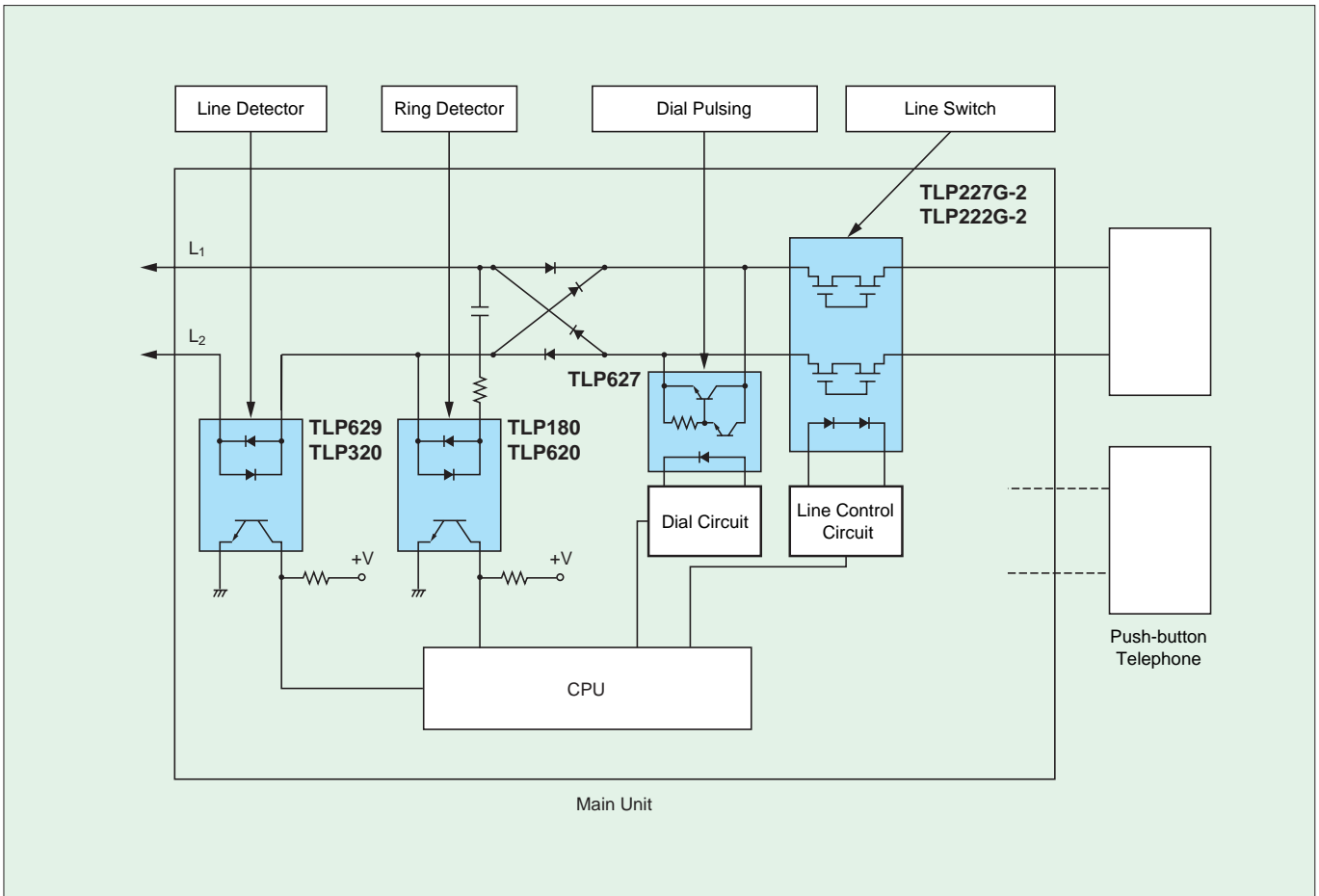

Application	Package Type	Part Number		Features
		DC Input	AC Input	
Ring Detector	DIP4	TLP421	TLP620	General single transistor output in compact packages Good cost performance
	Min flat	TLP181, TLP281	TLP180/280	
Dial Pulsing	DIP4	TLP627		High $V_{CE0} = 300\text{ V}$ Darlington transistor output in compact packages Suitable to generate pulse dial signal
	Min flat	TLP127		
	DIP4	TLP628		High $V_{CE0} = 350\text{ V}$ single transistor output.
Line Detector	DIP4	TLP629	TLP320	High LED current rating 150 mA Directly connectable in telephone line
Line Switch	DIP4	TLP222G*, TLP227G*		V _{OFF} = 400 V MOSFET output photorelay Crosspoint relay replacement (*: V _{OFF} = 350 V, **: V _{OFF} = 200 V)
	DIP6	TLP592G*, TLP597G*		
	DIP8 (Dual)	TLP222G-2*, TLP227G-2*		
	2.54SOP4	TLP172G*, TLP176D**, TLP176G*		
	2.54SOP6	TLP192G*, TLP197G*		
	2.54SOP8 (Dual)	TLP200D**, TLP202G*, TLP206G*		

8 Photocoupler Application Circuit Example

8.9 Photovoltaic Coupler Applications

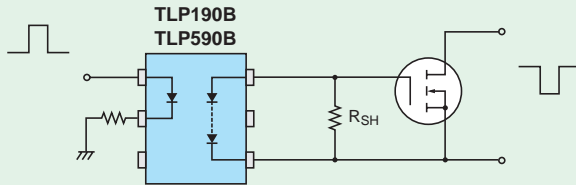

This is the simplest power MOSFET drive circuit. Resistor RSH for discharging the gate capacitor reduces turn-OFF time. This RSH is not required on the TLP591B which has a built-in resistor. (TON, TOFF \approx several ms)

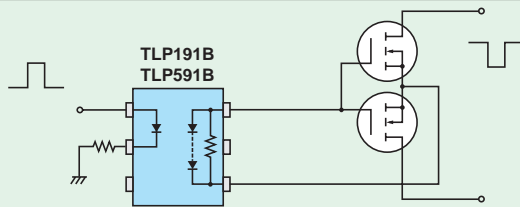

Drives for both AC and DC become possible by connecting power MOSFETs in a source common configuration.

Transformerless AC/DC converter

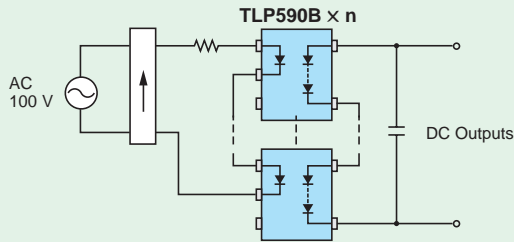

Photovoltaic couplers in parallel and serial configuration convert AC power to DC without a transformer. This type of configuration requires scores to hundreds of photovoltaic couplers.

8.10 Photorelay for Tester Application

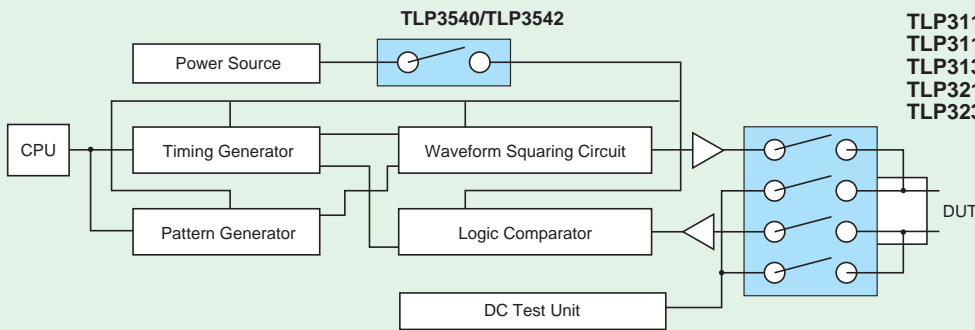

TLP3110/TLP3111
TLP3113 to TLP3116
TLP3130/TLP3131
TLP3213 to TLP3216
TLP3230 to TLP3231

8.11 Photorelay (MOSFET Output) Application

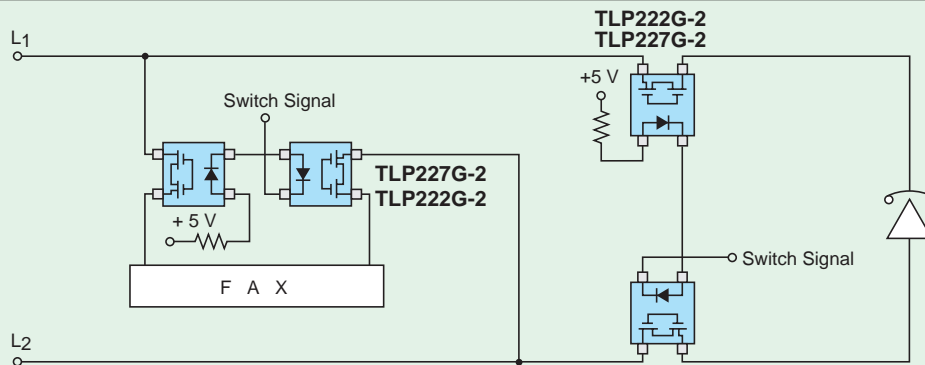

Application Example of Terminal Switching

8.12 NCU Circuit (FAX Modem Card) Application

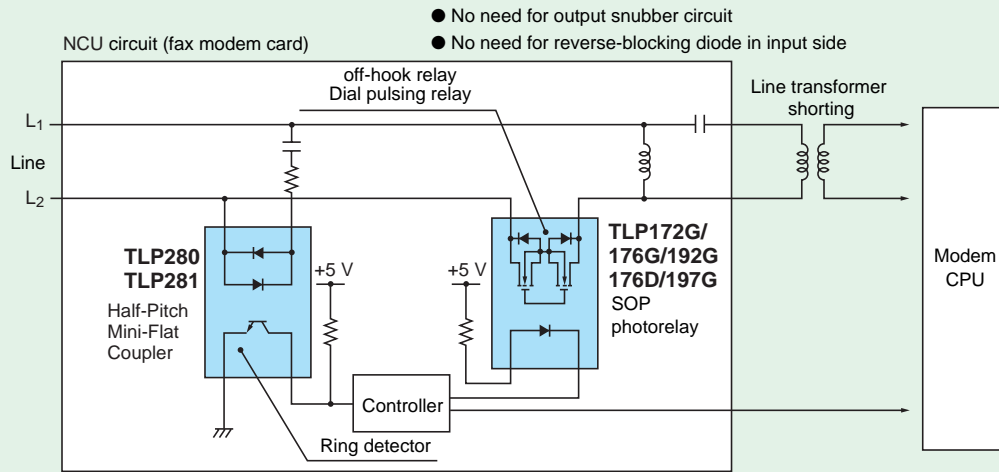

8.13 High-Speed Photo-IC Coupler Applications

Listed below are typical values.

	Dual Type	6-Pin Type	Mini-Flat Type	Output	Speed	Input Current I _F	Supply Voltage V _{CC}	Supply Current I _{CC}	CMR	Features	Applications
TLP250 				±0.5 A	0.2 μs	5 mA	10 to 35 V	10 mA	○	IGBT/Power MOSFET direct gate drive	<ul style="list-style-type: none"> ● General-purpose inverters ● Inverter air conditioners ● AC servo motor control ● IGBT/MOSFET drive
TLP251 			±0.1 A	0.3 μs							
TLP351 			±0.2 A	0.2 μs	5 mA						
TLP557 			-0.25/0.5 A	1 μs	5 mA	16 V or less	10 mA	○	Constant-current base drive, 15-A GTR direct drive	<ul style="list-style-type: none"> ● General-purpose inverters ● Inverter air conditioners ● AC servo motor control ● GTR base drive 	
TLP558 			3-state output	5 Mbit/s	1.6 mA	4.5 to 20 V	5 mA	○	Inverter logic Input 1 0 ↓ ↓ 0 1 Output	3-state output <ul style="list-style-type: none"> ● Computer data bus drivers ● High-speed digital signal interfaces ● High-speed gate drive for power MOSFETs ● Various industrial control equipment 	
TLP2200 			3-state output	5 Mbit/s	1.6 mA	4.5 to 20 V	5 mA	○	Buffer logic Input 1 0 ↓ ↓ 1 0 Output		

8 Photocoupler Application Circuit Example

8.13 High-Speed Photo-IC Coupler Applications (continued)

Listed below are typical values.

	Dual Type	6-Pin Type	SDIP	Mini-Flat Type	Output	Speed	Input Current I _F	Supply Voltage V _{CC}	Supply Current I _{CC}	CMR	Features	Applications
	TLP2601 	TLP2631 		TLP115/115A 	Open collector	10 Mbit/s	5 mA	5 V	12 mA (24 mA for dual type)	⊙	Internal noise shield, high CMR version of TLP552 and TLP2630	<ul style="list-style-type: none"> ● NC machines ● Industrial robots ● General-purpose inverters ● AC servo motor control ● Computer terminal devices ● Various industrial control equipment ● Electrostatic printers
				TLP116 	Totem pole	20 Mbit/s	5 mA	5 V	2 mA	⊙	Ultra-low power consumption, high-speed operation	<ul style="list-style-type: none"> ● PDPs ● Measuring instruments ● FA ● Control equipment ● OA equipment
	6N137 	TLP2630 	TLP513 	TLP113 	Open collector	10 Mbit/s	5 mA	5 V	12 mA (24 mA for dual type)	—	High-speed logic output	<ul style="list-style-type: none"> ● Electronic devices ● CD players ● High-speed digital signal interfaces ● Computer terminal devices
	6N138 6N139 				Open collector	0.3 Mbit/s	0.5 mA	18 V or less	0.1 mA	—	Low current drive	<ul style="list-style-type: none"> ● CMOS direct drive ● Current loop receiver/drivers ● Telephone ring detectors ● Computer terminal devices
	TLP551 TLP751 							15 V or less	0.1 mA (0.2 mA for dual type)	—	Photodiode/phototransistor separated, general-purpose transistor output device	<ul style="list-style-type: none"> ● CTV video signal isolation ● Analog signal transmission ● Digital signal interfaces
	TLP550 TLP750 	TLP2530 TLP2531 	TLP512 	TLP112/112A 	Open collector	1 Mbit/s	16 mA			○	No base connection	<ul style="list-style-type: none"> ● General-purpose inverters ● Inverter air conditioners ● AC servo motor control ● NC machines ● Switching power supply units
	TLP559 TLP759 		TLP719 	TLP114A 				30 V or less		⊙	Internal noise shield, high CMR version of TLP550	

*: SDIP version of the TLP559/759

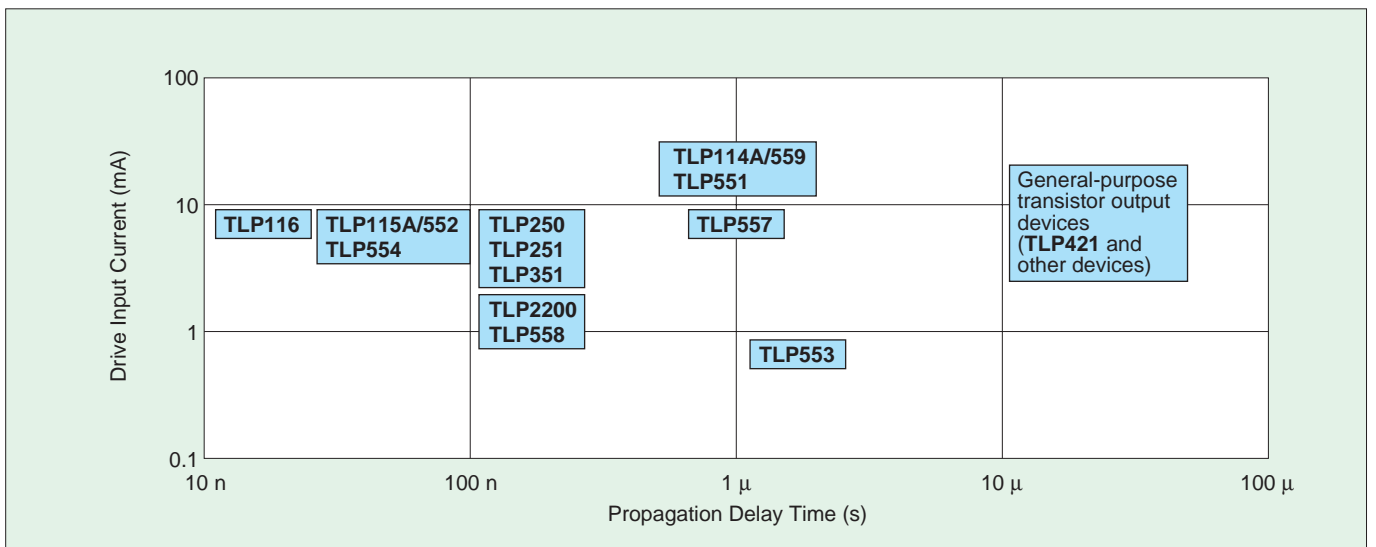

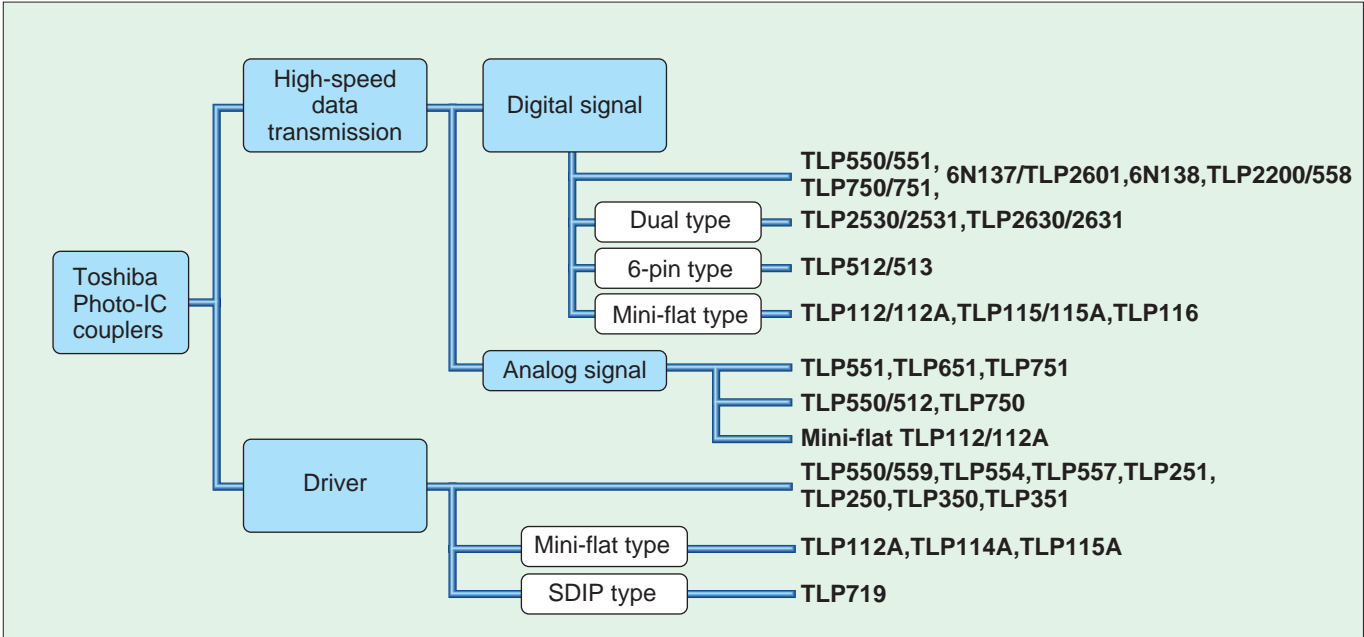

8 Photocoupler Application Circuit Example

8.14 Photorelay Applications

Package (number of channels, contact type)							Off voltage V_{OFF} Max	On current I_{ON} Max	Trigger current I_{FT} Typ.	Features	Applications
SSOP4(1ch,a)	SOP4(1ch,a)	SOP6(1ch,a)	SOP8(2ch,a)	DIP4(1ch,a)	DIP6(1ch,a)	DIP8(2ch,a)					
	TLP176A TLP172A	TLP197A TLP192A	TLP206A TLP202A	TLP225A TLP227A TLP222A	TLP597A TLP592A	TLP227A-2 TLP222A-2	60 V	0.3 to 0.5 A	1 to 2 mA	Low on-resistance High-current output	<ul style="list-style-type: none"> •Programmable controllers •Relay output I/O boards •Industrial robots •Measuring instruments •Gate drive for thyristor
	TLP176D	TLP197D	TLP200D				200 V	0.15 A	1 to 2 mA	FA switching	<ul style="list-style-type: none"> •Digital line cards •Industrial robots •Relay output I/O boards
	TLP176G TLP172G	TLP197G TLP192G	TLP206G TLP202G	TLP227G TLP222G	TLP594G TLP597G TLP592G	TLP222G-2 TLP227G-2	350 V	0.12 A	1 to 2 mA	High breakdown voltage Communication line switching Supports UL1950	<ul style="list-style-type: none"> •Public phone line cards •Analog modems •STBs •Various actuator drivers
	TLP176GA	TLP197GA	TLP206GA	TLP227GA	TLP597GA TLP798G TLP797GA	TLP227GA-2	400 V	0.12 A/ 0.15 A	1 to 2 mA	High breakdown voltage Communication line switching Supports UL1950	<ul style="list-style-type: none"> •Public phone line cards •Analog modems •STBs •Various actuator drivers
					TLP797J		600 V	0.1 A	1 to 2 mA	High breakdown voltage Communication line switching Supports UL1950	<ul style="list-style-type: none"> •Public phone line cards •Analog modems •STBs •Various actuator drivers
TLP3214 TLP3215 TLP3231	TLP3110 TLP3114 TLP3115 TLP3131						20 to 60 V	0.25 to 0.45A	2 to 3 mA	Low on-resistance for IC tester/measur- ing instrument Low CR products/ high current	<ul style="list-style-type: none"> •Memory testers •Logic testers •Measuring instruments
TLP3213 TLP3216 TLP3217 TLP3230	TLP3111 TLP3113 TLP3116 TLP3130						20 to 80 V	0.08 to 0.12 A	2 to 3 mA	Low on-resistance for IC testers/measur- ing instruments $C_{OFF} \leq 15$ pF Low CR product	<ul style="list-style-type: none"> •Memory testers •Logic testers •Measuring instruments

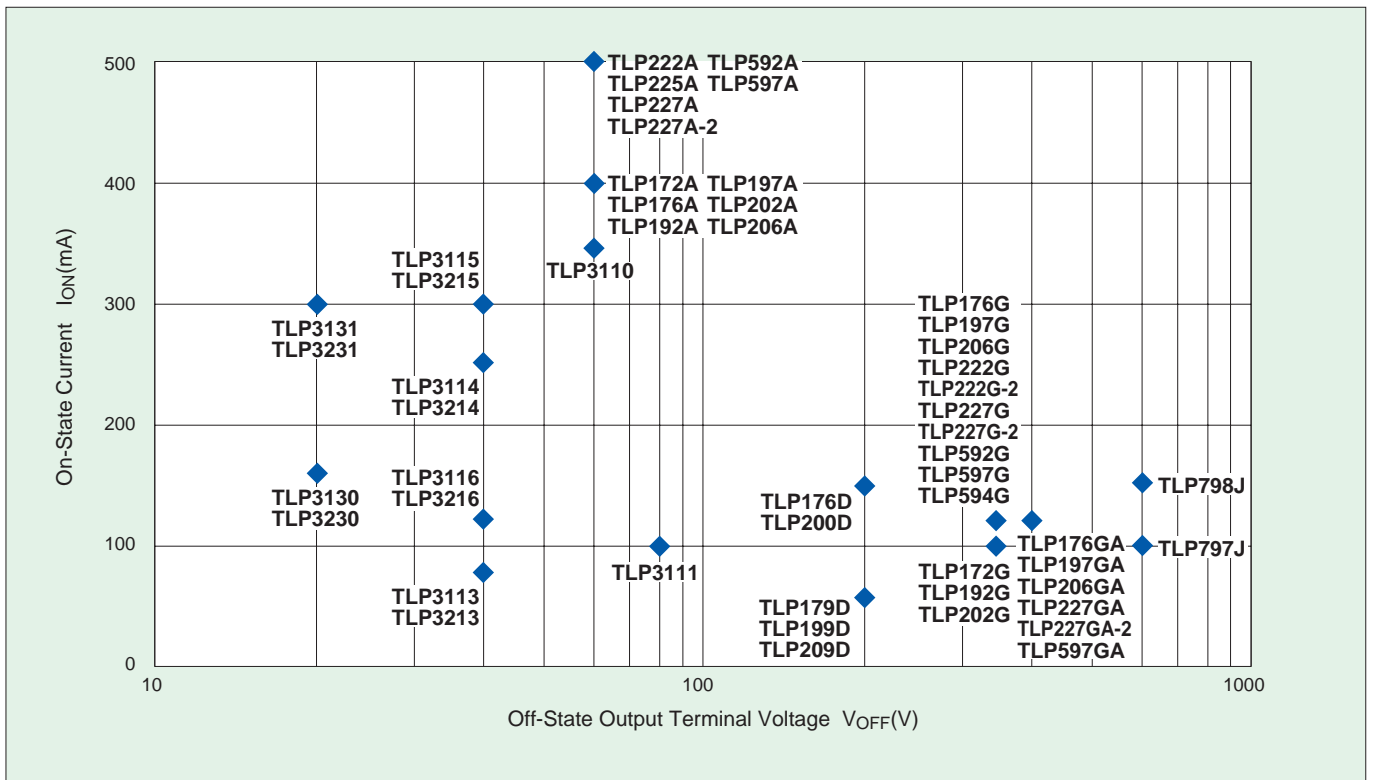

9 Competitor Cross Reference

9.1 Photocouplers

Fairchild

Part Number	TOSHIBA Part Number	Lv
H11A617	TLP421	B
H11A817	TLP421	A
H11AA814	TLP620(T)	B
H11B815	TLP627(T)	A
HMA121	TLP181(T)	A
HMA124	TLP124	A
HMA2701	TLP181(T)	A
HMHA2801	TLP281	A
HMHA281	TLP281	A
HMAA2705	TLP180(T)	A
HMHAA280	TLP280	A
H11A1	TLP631	A
H11AA1	TLP630	A
H11AG1	TLP331	A
H11B1	TLP571	A
H11C1	TLP541G	A
H11D1	TLP371	C
H11G1	TLP371	A
MOC3021-M	TLP3021(S)	A
MOC3022-M	TLP3022(S)	A
MOC3023-M	TLP3023(S)	A
MOC3041-M	TLP3041(S)	A
MOC3042-M	TLP3042(S)	A
MOC3043-M	TLP3043(S)	A
MOC3051-M	TLP3051(S)	A
MOC3052-M	TLP3052(S)	A
MOC3061-M	TLP3061(S)	A
MOC3062-M	TLP3062(S)	A
MOC3063-M	TLP3063(S)	A

COSMO

Part Number	TOSHIBA Part Number	Lv
K1010	TLP421	A
K1020	TLP621-2(T)	A
K2010	TLP631	B
K3010	TLP620(T)	B
KP3020	TLP620-2(T)	B
KP4010	TLP627(T)	A
KP4020	TLP627-2(T)	A
K5010	TLP371	A
K6010	TLP630	A
KPS2801	TLP281	A
KPC354NT	TLP180(T)	B
KPC355NT	TLP127	A
KPC357NT	TLP181(T)	A
KPC452	TLP127	A

LITEON

Part Number	TOSHIBA Part Number	Lv
LTV-123	TLP421	A
LTV-816	TLP421	A
LTV-817	TLP421	A
LTV-851	TLP628	A
LTV-356T	TLP181(T)	A
LTV-357T	TLP181(T)	A
LTV-814	TLP620(T)	B
LTV-814H	TLP320	A
LTV-354T	TLP180(T)	B
LTV-815	TLP627(T)	A
LTV-852	TLP627(T)	A
LTV-352T	TLP127	A
LTV-355T	TLP127	B
MOC3020	TLP3020(S)	A
MOC3021	TLP3021(S)	A
MOC3022	TLP3022(S)	A
MOC3023	TLP3023(S)	A
MOC3051	TLP3051(S)	A
MOC3052	TLP3052(S)	A
MOC3061	TLP3061(S)	A
MOC3062	TLP3062(S)	A
MOC3063	TLP3063(S)	A

Agilent

Part Number	TOSHIBA Part Number	Lv
HCPL-M600	TLP115A	A
HCPL-M601	TLP115A	A
HCPL-M611	TLP115A	A
HCPL-M452	TLP114A	A
HCPL-M453	TLP114A	A
HCPL-M456	TLP114A	A
HCPL-2601	TLP2601	A
HCPL-2611	TLP2601	A
HCPL-2201	TLP555	B
HCPL-2530	TLP2530	A
HCPL-2531	TLP2531	A
HCPL-2630	TLP2631	A
HCPL-2631	TLP2631	A
HCPL-3120	TLP350	A
HCPL-3140	TLP351	A
HCPL-3150	TLP351	A
HCPL-3180	TLP350	B
HCPL-314J	TLP701 x2	C
HCPL-4504	TLP559	A
HCPL-0708	TLP116	B
HCPL-181	TLP181(T)	A
HCPL-354	TLP180(T)	B
HCPL-814	TLP620(T)	B
HCPL-817	TLP421	A

Vishay

Part Number	TOSHIBA Part Number	Lv
K817P	TLP421	A
SFH610A	TLP421	A
SFH614A	TLP628	A
SFH615A	TLP421	A
SFH617A	TLP421	A
SFH618A	TLP624	B
TCET1100	TLP421	A
SFH690xT	TLP181(T)	A
TCMT1100	TLP281	A
TCMT4100	TLP281-4	A
SFH628A	TLP620(T)	B
K815P	TLP627(T)	A
SFH612A	TLP627(T)	A
SFH619A	TLP627(T)	A
SFH655A	TLP627(T)	A
SFH692AT	TLP127	A
TCED1100	TLP627(T)	A
IL66	TLP371	A
IL66B	TLP372	A
IL255	TLP330	A

Code

A: Direct replacement

B: Smaller package size

C: Electrical improvement (pin layout changed)

9 Competitor Cross Reference

9.2 Photorelays

NEC

Part Number	TOSHIBA Part Number	Lv
PS2501-1	TLP421	A
PS2561-1	TLP421	A
PS2571-1	TLP421	A
PS2581-1	TLP421F	A
PS2505-1	TLP620(T)	B
PS2565-1	TLP620(T)	B
PS2502-1	TLP627(T)	A
PS2562-1	TLP627(T)	A
PS2532-1	TLP627(T)	A
PS2533-1	TLP627(T)	A
PS2521-1	TLP629	B
PS2525-1	TLP320	B
PS2701-1	TLP181(T)	A
PS2761-1	TLP181(T)	A
PS2705-1	TLP180(T)	A
PS2765-1	TLP180(T)	A
PS2702-1	TLP127	A
PS2801-1	TLP281	A
PS2801-4	TLP281-4	A
PS2861-1	TLP281	A
PS2805-1	TLP280	A
PS2805-4	TLP280-4	A
PS2865-1	TLP280	A
PS2811-1	TLP283	B
PS2811-4	TLP283-4	B
PS8601	TLP759	B
PS8602	TLP759	A
PS9613	TLP759(IGM)	A
PS8701	TLP114A	B
PS8101	TLP114A	B
PS9713	TLP114A(IGM)	B
PS9113	TLP114A(IGM)	B
PS9601	TLP554	A
PS9614	TLP554	B
PS9714	TLP115A	B
PS9114	TLP115A	B
PS9715	TLP115A	B
PS9115	TLP115A	B
PS9701	TLP115A	A
PS7141-1A	TLP597GA	A
PS7141-2A	TLP227GA-2	A
PS7141-1B	TLP4597G	B
PS7141-2B	TLP4227G-2	B
PS7141-1C	TLP4006G	B
PS7341C-1A	TLP594G	B
PS7341C-2A	TLP224G-2	B
PS7241-1A	TLP176GA	A
PS7241-2A	TLP206GA	A
PS7241-1B	TLP4176G	B
PS7241-2B	TLP4206G	B
PS7241-1C	TLP4026G	B

SHARP

Part Number	TOSHIBA Part Number	Lv
PC123	TLP421	A
PC817	TLP421	A
PC813	TLP620	A
PC815	TLP627	A
PC357NT	TLP181(T)	A
PC354NT	TLP180(T)	A
PC355NT	TLP127	A
PC3H7	TLP281	A
PC3H3	TLP280	A
PC3H21	TLP525G	A
PC410	TLP115A	A
PC942	TLP351	A
PC923	TLP351	A
S2S3	TLP260J	B
S2S4	TLP161J	B
PR36MF11NSZ	TLP3506	B
PR36MF12NSZ	TLP3506	B
S21MD3V	TLP3051(S)	A
S201D01	TLP3526	B
S201D02	TLP3527	B

AROMAT(NAIS)

Part Number	TOSHIBA Part Number	Lv
AQV210	TLP592G	A
AQV210E	TLP597G	A
AQV210EH	TLP797GA	A
AQV210S	TLP192G	A
AQV212	TLP592A	A
AQV212S	TLP197A	A
AQV214	TLP597GA	A
AQV214E	TLP597G	A
AQV214EH	TLP797GA	A
AQV214H	TLP797GA	A
AQV214S	TLP797GA	A
AQV215	TLP597A	B
AQV216	TLP797J	A
AQV217S	TLP197D	A
AQV410EH	TLP4592G	A
AQV414	TLP4592G	A
AQV414E	TLP4597G	A
AQV414S	TLP4197G	A
AQW210	TLP222G-2	A
AQW210S	TLP202G	A
AQW212	TLP222A-2	A
AQW214	TLP227GA-2	A
AQW215	TLP222A-2	B
AQW217	TLP222G-2	A
AQW414	TLP4222G-2	A
AQW610S	TLP4026G	A
AQW614	TLP4007G	A
AQY210EH	TLP227G	A
AQY210LS	TLP174G	A
AQY210S	TLP174G	A
AQY214EH	TLP227G	A
AQY214S	TLP176GA	A
AQY410EH	TLP4227G	A
AQY414EH	TLP4227G	B
AQY414S	TLP4176G	A
AQY221N1S	TLP3113/TLP3116	B
AQY221N2S	TLP3113/TLP3116	B
AQY221R2V	TLP3215	A
AQY221N2V	TLP3215	A
AQY221N2V	TLP3216	A

10 Discontinued and Final-Phase Products

10.1 Discontinued Products

Part Number	Replacement	Code
TLP101	TLP181	B
TLP190	TLP190B	C
TLP191	TLP191B	C
TLP215	-	
TLP216	-	
TLP501	TLP521-1	A
TLP503	TLP531	B
TLP504	TLP504A	B
TLP505D	TLP541G	B
TLP505G	TLP541G	B
TLP506D	TLP511GA	B
TLP506G	TLP511GA	B
TLP508	TLP531	C
TLP509	TLP532	B
TLP510G	TLP541G	B
TLP511G	TLP511GA	C
TLP516G	TLP3520A	A
TLP516J	TLP3526	A
TLP519	TLP532	C

Part Number	Replacement	Code
TLP533	TLP733	D
TLP534	TLP734	D
TLP546G	TLP3520A	A
TLP547G	TLP747G	D
TLP547J	TLP747J	D
TLP573	TLP592A	A
TLP580	TLP734F	A
TLP581	TLP733F	A
TLP582	-	A
TLP590	TLP590B	A
TLP590A	TLP590B	A
TLP591	TLP591B	A
TLP591A	TLP591B	A
TLP633	TLP733	A
TLP634	TLP734	A
TLP647G	TLP747G	A
TLP647J	TLP747J	A
TLP796G	TLP798G/TLP797GA	A

10.2 Final-Phase Products

Part Number	Replacement	Code
TLP120-4	TLP180	C
TLP121-4	TLP181	C
TLP124-4	TLP124	C
TLP127-4	TLP127	C
TLP3560	-	-
TLP3561	-	-
TLP3566	-	-
TLP3567	-	-
TLP546G	TLP3520A	B, C
TLP573	TLP598A/599A	B, C
TLP580	TLP732F	B, C
TLP581	TLP731F	B, C
TLP582	-	-

Part Number	Replacement	Code
TLP633/634	TLP731/732	B
TLP635/635F	TLP631/631(LF2)	B
TLP635/637F	TLP331/331(LF2)	B
TLP636/636F	TLP632/632(LF2)	B
TLP638/638F	TLP332/332(LF2)	B
TLP639/639F	TLP630/630(LF2)	B
TLP645G/645GF	TLP741G/741G(LF2)	B
TLP645J/645JF	TLP741J/741J(LF2)	B
TLP647G/647J	TLP747G/747J	B
TLP675/675F	TLP371/371(LF2)	B
TLP676/676F	TLP372/372(LF2)	B
TLP677/677F	TLP371/371(LF2)	B
TLP678/678F	TLP372/372(LF2)	B

Code
A: Direct replacement
B: Smaller package size
C: Electrical improvement (pin layout changed)

**Toshiba America
Electronic Components, Inc.**

Headquarters-Irvine, CA
9775 Toledo Way, Irvine, CA 92618, U.S.A.
Tel: (949)455-2000 Fax: (949)859-3963

Boulder, CO (Denver)
3100 Arapahoe #500,
Boulder, CO 80303, U.S.A.
Tel: (303)442-3801 Fax: (303)442-7216

Deerfield, IL (Chicago)
One Pkwy., North, #500, Deerfield,
IL 60015-2547, U.S.A.
Tel: (847)945-1500 Fax: (847)945-1044

Duluth, GA (Atlanta)
3700 Crestwood Pkwy, #160,
Duluth, GA 30096, U.S.A.
Tel: (770)931-3363 Fax: (770)931-7602

Edison, NJ
2035 Lincoln Hwy, #3000, Edison,
NJ 08817, U.S.A.
Tel: (732)248-8070 Fax: (732)248-8030

Beaverton/Portland, OR
8323 SW Cirrus Drive, Beaverton,
OR 97008, U.S.A.
Tel: (503)466-3721 Fax: (503)629-0827

Raleigh, NC
3120 Highwoods Blvd., #108, Raleigh,
NC 27604, U.S.A.
Tel: (919)859-2800 Fax: (919)859-2898

Richardson, TX (Dallas)
777 East Campbell Rd., #650, Richardson,
TX 75081, U.S.A.
Tel: (972)480-0470 Fax: (972)235-4114

San Jose Engineering Center, CA
1060 Rincon Circle, San Jose, CA 95131, U.S.A.
Tel: (408)526-2400 Fax: (408)526-8910

Wakefield, MA (Boston)
599 North Ave. #8, Wakefield, MA, U.S.A.
Tel: (781)246-5076 Fax: (781)246-8502

Toshiba do Brasil, S.A.

Electronics Component Div.
Rua Afonso Celso, 55213 ardar,
Vila Mariana CEP 04119-002, São Paulo, Brasil
Tel: (011)5576-6619 Fax: (011)5576-6607

Toshiba India Private Ltd.

6F DR, Gopal Das Bhawan 28,
Barakhamba Road, New Delhi, 110001, India
Tel: (011)2371-4601 Fax: (011)2371-4603

Toshiba Electronics Europe GmbH

Düsseldorf Head Office
Hansaallee 181, D-40549 Düsseldorf,
Germany
Tel: (0211)5296-0 Fax: (0211)5296-400

München Office
Büro München Hofmannstrasse 52,
D-81379, München, Germany
Tel: (089)748595-0 Fax: (089)748595-42

Toshiba Electronics France S.A.R.L.
Les Jardins du Golf 6 rue de Rome 93561,
Rosny-Sous-Bois, Cedex, France
Tel: (1)48-12-48-12 Fax: (1)48-94-51-15

Toshiba Electronics Italiana S.R.L.
Centro Direzionale Colleoni,
Palazzo Perseo 3,
I-20041 Agrate Brianza, (Milan), Italy
Tel: (039)68701 Fax: (039)6870205

Toshiba Electronics España, S.A.
Parque Empresarial, San Fernando, Edificio Europa,
1ª Planta, E-28831 Madrid, Spain
Tel: (91)660-6798 Fax: (91)660-6799

Toshiba Electronics (UK) Ltd.
Riverside Way, Camberley Surrey,
GU15 3YA, U.K.
Tel: (01276)69-4600 Fax: (01276)69-4800

Toshiba Electronics Scandinavia A.B.
Gustavslundsvägen 18, 5th Floor,
S-167 15 Bromma, Sweden
Tel: (08)704-0900 Fax: (08)80-8459

**Toshiba Electronics Asia
(Singapore) Pte. Ltd.**

Singapore Head Office
438B Alexandra Road, #06-08/12 Alexandra
Technopark, Singapore 119968
Tel: (6278)5252 Fax: (6271)5155

**Toshiba Electronics Service
(Thailand) Co., Ltd.**

135 Moo 5, Bangkadi Industrial Park, Tivanon Road,
Pathumthani, 12000, Thailand
Tel: (02)501-1635 Fax: (02)501-1638

**Toshiba Electronics Trading
(Malaysia) Sdn. Bhd.**

Kuala Lumpur Head Office
Suite W1203, Wisma Consplant, No.2,
Jalan SS 16/4, Subang Jaya, 47500 Petaling Jaya,
Selangor Darul Ehsan, Malaysia
Tel: (03)5631-6311 Fax: (03)5631-6307

Penang Office
Suite 13-1, 13th Floor, Menara Penang Garden,
42-A, Jalan Sultan Ahmad Shah,
10050 Penang, Malaysia
Tel: (04)226-8523 Fax: (04)226-8515

Toshiba Electronics Philippines, Inc.
26th Floor, Citibank Tower, Valero Street, Makati,
Manila, Philippines
Tel: (02)750-5510 Fax: (02)750-5511

Toshiba Electronics Asia, Ltd.

Hong Kong Head Office
Level 11, Tower 2, Grand Century
Place, No.193, Prince Edward Road West,
Mongkok, Kowloon, Hong Kong
Tel: 2375-6111 Fax: 2375-0969

Beijing Office
Room 714, Beijing Fortune Building,
No.5 Dong San Huan Bei-Lu, Chao Yang District,
Beijing, 100004, China
Tel: (010)6590-8796 Fax: (010)6590-8791

Chengdu Office
Suite 403A, Holiday Inn Crown Plaza 31, Zongfu Street,
Chengdu, 610016, Sichuan, China
Tel: (028)675-1773 Fax: (028)675-1065

Qingdao Office
Room B707, Full Hope Plaza,
12 Hong Kong Central Road, Qingdao,
Shandong, 266071, China
Tel: (0532)502-8105 Fax: (0532)502-8109

Toshiba Electronics Shenzhen Co., Ltd.
Room 909, 9/F, Futian Free Trade Zone, 9 Shihua Road,
Shenzhen, 518008, China
Tel: (0755)2583-0810 Fax: (0755)8246-1581

Toshiba Electronics Korea Corporation

Seoul Head Office
891, Sejong Securities Bldg, 20F, Daechi-dong,
Gangnam-gu, Seoul, 135-738, Korea
Tel: (02)3484-4334 Fax: (02)3484-4302

Gumi Office
6F, Goodmorning Securities Building,
56 Songjung-dong, Gumi-shi,
Kyeongbuk, 730-090, Korea
Tel: (054)456-7613 Fax: (054)456-7617

Toshiba Electronics (Shanghai) Co., Ltd.
11F, HSBC Tower, 101
Yin Cheng East Road, Pudong New Area, Shanghai,
200120, China
Tel: (021)6841-0666 Fax: (021)6841-5002

Hangzhou Office
9F Zhejiang San Rui Bldg. No. 36 QingChun Road,
Hangzhou 310004, China
Tel: (0571)8704-0255 Fax: (0571)8704-0200

Tsurong Xiamen Xiangyu Trading Co., Ltd.
8N, Xiamen SEZ Bonded Goods Market Building,
Xiamen, Fujian, 361006, China
Tel: (0592)562-3798 Fax: (0592)562-3799

Toshiba Electronics Taiwan Corporation

Taipei Head Office
17F, Union Enterprise Plaza Building, 109
Min Sheng East Road, Section 3, Taipei,
105, Taiwan
Tel: (02)2514-9988 Fax: (02)2514-7892

Kaohsiung Office
16F-A, Chung-Cheng Building, 2, Chung-Cheng 3Road,
Kaohsiung, 800, Taiwan
Tel: (07)237-0826 Fax: (07)236-0046

The information contained herein is subject to change without notice. 021023_D

The information contained herein is presented only as a guide for the applications of our products. No responsibility is assumed by TOSHIBA for any infringements of patents or other rights of the third parties which may result from its use. No license is granted by implication or otherwise under any patent or patent rights of TOSHIBA or others. 021023_C

TOSHIBA is continually working to improve the quality and reliability of its products. Nevertheless, semiconductor devices in general can malfunction or fail due to their inherent electrical sensitivity and vulnerability to physical stress. It is the responsibility of the buyer, when utilizing TOSHIBA products, to comply with the standards of safety in making a safe design for the entire system, and to avoid situations in which a malfunction or failure of such TOSHIBA products could cause loss of human life, bodily injury or damage to property. In developing your designs, please ensure that TOSHIBA products are used within specified operating ranges as set forth in the most recent TOSHIBA products specifications. Also, please keep in mind the precautions and conditions set forth in the "Handling Guide for Semiconductor Devices," or "TOSHIBA Semiconductor Reliability Handbook" etc. 021023_A

The Toshiba products listed in this document are intended for usage in general electronics applications (computer, personal equipment, office equipment, measuring equipment, industrial robotics, domestic appliances, etc.). These Toshiba products are neither intended nor warranted for usage in equipment that requires extraordinarily high quality and/or reliability or a malfunction or failure of which may cause loss of human life or bodily injury ("Unintended Usage"). Unintended Usage include atomic energy control instruments, airplane or spaceship instruments, transportation instruments, traffic signal instruments, combustion control instruments, medical instruments, all types of safety devices, etc. Unintended Usage of Toshiba products listed in this document shall be made at the customer's own risk. 021023_B

TOSHIBA products should not be embedded to the downstream products which are prohibited to be produced and sold, under any law and regulations. 030519_Q

GaAs(Gallium Arsenide) is used in some of the products. The dust or vapor is harmful to the human body. Do not break, cut, crush or dissolve chemically. 021023_J

TOSHIBA**TOSHIBA CORPORATION**
Semiconductor CompanyWebsite: <http://www.semicon.toshiba.co.jp/eng>

©2004 TOSHIBA CORPORATION

Previous edition: 3628C-0109

2004-2(0.5k)PC-O

Printed in Japan



100% recycled paper