

T-74-09-01

HYBRID VHF/UHF WIDE-BAND AMPLIFIER

Three-stage wide-band amplifier in the hybrid technique, designed for use in mast-head booster-amplifiers, as preamplifier in MATV systems, and as general-purpose amplifier for v.h.f. and u.h.f. applications.

QUICK REFERENCE DATA

Frequency range	f	40 to 860 MHz
Source and load (characteristic) impedance	$R_s = R_l = Z_o$	= 75 Ω
Transducer gain	$G_{tr} = s_f ^2$	typ. 22 dB
Flatness of frequency response	$\pm \Delta s_f ^2$	typ. 1,0 dB
Output voltage at -60 dB intermodulation distortion (DIN 45004, 3-tone)	$V_o(rms)$	> 105 dB μ V
Noise figure	F	typ. 7 dB
D.C. supply voltage	V_B	= 24 V \pm 10%
Operating ambient temperature	T_{amb}	-20 to +70 $^{\circ}$ C

ENCAPSULATION 7-pin, in-line, resin-coated body, see MECHANICAL DATA

CIRCUIT DIAGRAM

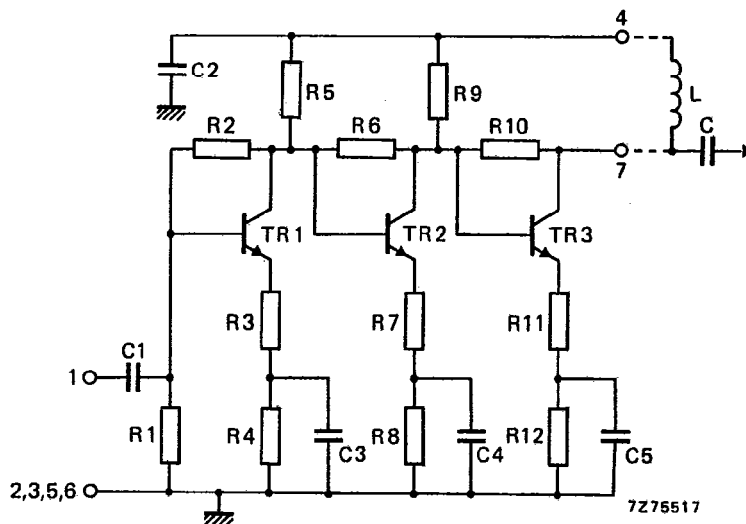

T-74-09-01

RATINGS

Limiting values in accordance with the Absolute Maximum System (IEC 134)

Operating ambient temperature	T_{amb}	-20 to +70 °C
Storage temperature	T_{stg}	-40 to +125 °C
D.C. supply voltage	V_B	max. 28 V
Peak voltages on pins 1 and 7	V_{1M}, V_{7M} $-V_{1M}, -V_{7M}$	max. 28 V max. 10 V
Peak incident powers on pins 1 and 7	P_{11M}, P_{17M}	max. 100 mW

CHARACTERISTICS

Measuring conditions

V.H.F.-U.H.F. test socket	catalogue no. 3504 110 01840 *
Ambient temperature	$T_{amb} = 25$ °C
D.C. supply voltage	$V_B = 24$ V
Source impedance and load impedance	$R_s, R_l = 75$ Ω
Characteristic impedance of h.f. connections	$Z_0 = 75$ Ω
Frequency range	$f = 40$ to 860 MHz

Performance

Supply current	I_B	typ. 65 mA
Transducer gain	$G_{tr} = s_f ^2$	20 to 24 dB typ. 22 dB
Flatness of frequency response	$\pm \Delta s_f ^2$	typ. 1,0 dB
Individual maximum v.s.w.r.		
input	VSWR(i)	typ. 1,4 **
output	VSWR(o)	typ. 1,6 **
Back attenuation		
$f = 100$ MHz	$ s_r ^2$	typ. 42 dB
$f = 860$ MHz	$ s_r ^2$	typ. 40 dB
Output voltage		
at -60 dB intermodulation distortion		
(DIN 45004, par. 6.3: 3-tone)	$V_{O(rms)}$	> 105 dBμV typ. 107 dBμV
Noise figure	F	typ. 7 dB

s-parameters:	$s_f = s_{21}$	$s_l = s_{11}$
	$s_r = s_{12}$	$s_o = s_{22}$

* This socket can be made available for customer reference purposes.
** Highest value, for a sample, occurring in the frequency range.

OPERATING CONDITIONS

Ambient temperature range	T_{amb}	-20 to +70 °C
D.C. supply voltage	V_B	= 24 V ±10%
Frequency range	f	40 to 860 MHz
Source impedance and load impedance	R_s, R_l	= 75 Ω

MECHANICAL DATA

Dimensions in mm

Encapsulation

The device is resin coated.

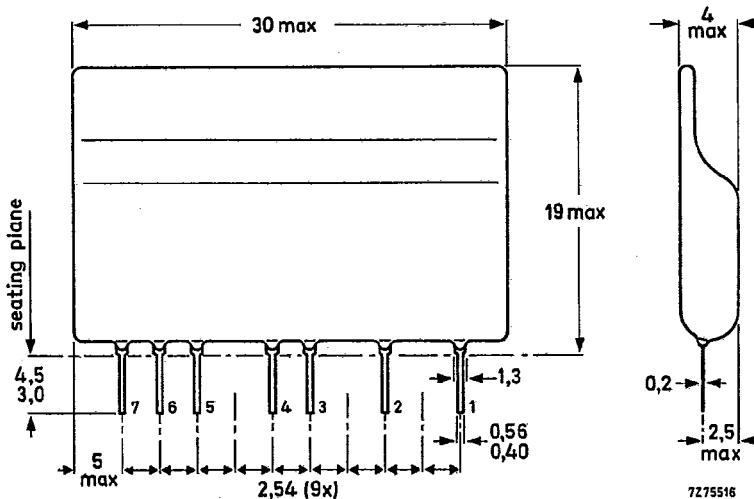

Terminal connections

- 1 = Input
- 2, 3, 5, 6 = Common
- 4 = Supply (+)
- 7 = Output.

Soldering recommendations

Hand soldering

Maximum contact time for a soldering-iron temperature of 260 °C up to the seating plane is 5 s.

Dip or wave soldering

260 °C is the maximum permissible temperature of the solder; it must not be in contact with the joint for more than 5 seconds. The total contact time of successive solder waves must not exceed 5 seconds. The device may be mounted against the printed-circuit board, but the temperature of the device must not exceed 125 °C. If the printed-circuit board has been pre-heated, forced cooling may be necessary immediately after soldering to keep the temperature below the allowable limit.

Mounting recommendations

The module should preferably be mounted on double-sided printed-circuit board, see the example shown below.

Input and output should be connected to 75 Ω tracks.

The connections to the 'common' pins should be as close to the seating plane as possible.

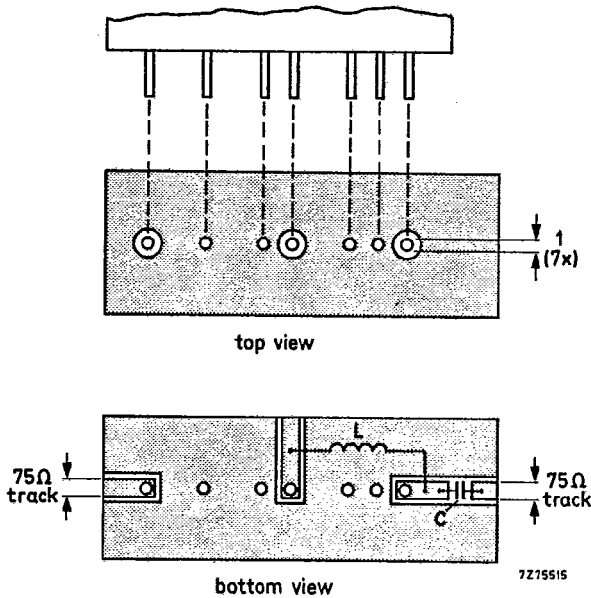

$L > 5 \mu\text{H}$; e.g. catalogue no. 3122 108 20150 or 27 turns enamelled Cu wire (0,3 mm) wound on a ferrite core with a diameter of 1,6 mm.

$C > 220 \text{ pF}$ ceramic capacitor.

