



GENERAL PURPOSE GaAs MESFET

NE720 SERIES

T-31-25

FEATURES

- **LOW COST**
- **LOW NOISE FIGURE**
0.8 dB at 4 GHz
1.7 dB at 8 GHz
- **HIGH ASSOCIATED GAIN**
12.0 dB at 4 GHz
9.0 dB at 8 GHz
- **HIGH MAXIMUM AVAILABLE GAIN**
16.0 dB at 4 GHz
12.0 dB at 8 GHz

DESCRIPTION AND APPLICATIONS

The NE720 is NEC's low cost 1.0 μ recessed gate GaAs FET, offering a low noise figure and high gain through 8 GHz. It is designed for consumer applications.

The device is available as a chip (NE72000) and in two hermetically sealed stripline packages (NE72084 and NE72089A). The chip's gate and channel are glassivated with a thin layer of SiO₂ for mechanical protection. All bonding pads use a Ti-Pt-Au metallization system.

OUTLINE DIMENSIONS (Units in mm)

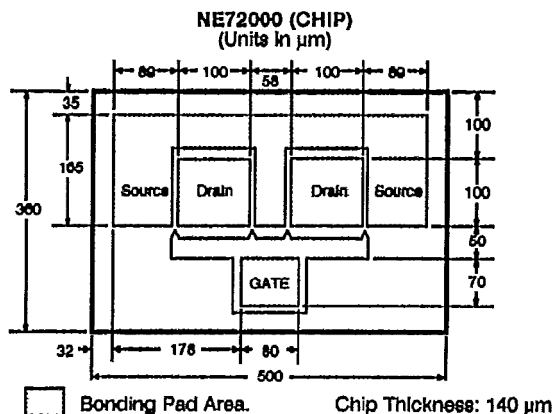

OUTLINE 84 (Units in mm)

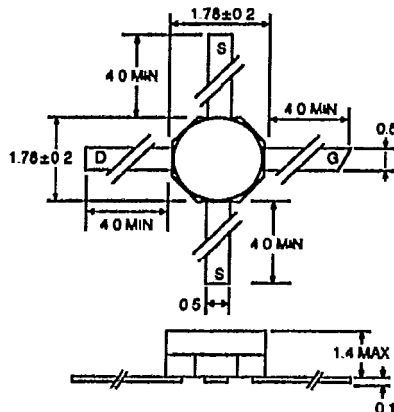

OUTLINE 89A

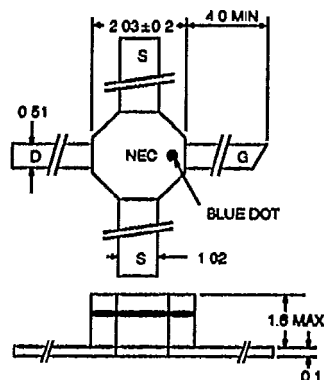

ABSOLUTE MAXIMUM RATINGS (T_A = 25°C)

SYMBOLS	PARAMETERS	UNITS	RATINGS
V _{DS}	Drain to Source Voltage	V	5.0
V _{GD0}	Gate to Drain Voltage	V	-6.0
V _{GS0}	Gate to Source Voltage	V	-6.0
I _{GF}	Gate Current	mA	4.0
I _{DS}	Drain Current	mW	150
T _{CH}	Channel Temperature	°C	175
T _{STG}	Storage Temperature	°C	-65 to +125
	NE72084	°C	-65 to +175
	NE72089A	°C	-65 to +175

ELECTRICAL CHARACTERISTICS (T_A = 25°C)

PART NUMBER EIAJ ¹ REGISTERED NUMBER PACKAGE OUTLINE			NE72000 00 (CHIP)			NE72084 2SK571 84			NE72089A 2SK354A 89A		
SYMBOLS	PARAMETERS AND CONDITIONS	UNITS	MIN	TYP	MAX	MIN	TYP	MAX	MIN	TYP	MAX
I _{DSS}	Drain Current at V _{DS} = 3 V, V _{GS} = 0 V	mA	30	60	150	30	60	150	30	60	150
V _P	Pinch-off Voltage at V _{DS} = 3 V, I _{DS} = 0.1 mA	V	-0.8	-2.0	-4.0	-0.8	-2.0	-4.0	-0.8	-2.0	-4.0
g _M	Transconductance at V _{DS} = 3 V, I _{DS} = 10 mA	mS	20	40	60	20	40	60	20	40	60
I _{GSO}	Gate to Source Leakage Current at V _{GS} = -5 V	μA		1.0	10			10		1.0	10
R _{TH}	Thermal Resistance (Channel-to-Ambient)	°C/W			170 ²			400			400
P _T	Total Power Dissipation	mW			500			300			300

Notes:

- Electronic Industrial Association of Japan.
- R_{TH} (Channel-to-Case) for chips mounted on a copper heatsink.

PERFORMANCE SPECIFICATIONS (T_A = 25°C)

PART NUMBER EIAJ ¹ REGISTERED NUMBER PACKAGE OUTLINE			NE72000 00 (CHIP)			NE72084 2SK571 84			NE72089A 2SK354A 89A		
SYMBOLS	PARAMETERS AND CONDITIONS	UNITS	MIN	TYP	MAX	MIN	TYP	MAX	MIN	TYP	MAX
f _{MAX}	Maximum Frequency of Oscillation at V _{DS} = 3 V, I _{DS} = 30 mA	GHz		60			60			60	
MAG	Maximum Available Gain ² at V _{DS} = 3 V, I _{DS} = 30 mA (Typ. I _{DS} = 50% I _{DSS}) f = 2 GHz f = 4 GHz f = 8 GHz f = 12 GHz	dB dB dB dB		16.5 11.5			17.5 15.0 12.0 8.0			16.0 11.0	
N _{FOP}	Optimum Noise Figure ³ at V _{DS} = 3 V, I _{DS} = 10 mA (Typ. I _{DS} = 15% I _{DSS}) f = 2 GHz f = 4 GHz f = 8 GHz	dB dB dB		1.0 1.7	1.4 ⁴		0.6 0.8 2.0	1.4		1.0 1.7	1.4
GA	Associated Gain at NF at V _{DS} = 3 V, I _{DS} = 10 mA (Typ. I _{DS} = 15% I _{DSS}) f = 2 GHz f = 4 GHz f = 8 GHz	dB dB dB		11.0 9.0			15.0 12.0 8.5			11.0 8.5	
P _{1dB}	Output Power at 1 dB Compression Point at V _{DS} = 4 V, I _{DS} = 30 mA (Typ. I _{DS} = 50% I _{DSS}) f = 4 GHz	dBm		15.0			15.0			15.0	

Notes:

- Electronic Industrial Association of Japan.
- Gain Calculations: $MAG = \frac{|S_{21}|}{|S_{12}|} (K \pm \sqrt{K^2 - 1})$, $K = \frac{1 + |\Delta|^2 - |S_{11}|^2 - |S_{22}|^2}{2|S_{12}||S_{21}|}$, $\Delta = S_{11}S_{22} - S_{21}S_{12}$
- Typical values of noise figures are those obtained when 50% of the devices from a large number of lots were individually measured in a circuit with the input individually tuned to obtain the minimum value. Maximum values are criteria established on the production line as a "go-no-go" screening tuned for the "generic" type but not for each specimen.
- RF performance is determined by packaging and testing 10 samples per wafer; wafer rejection criteria for standard devices is 2 rejects for 10 samples.

NE720 SERIES

TYPICAL PERFORMANCE CHARACTERISTICS (T_A = 25°C)

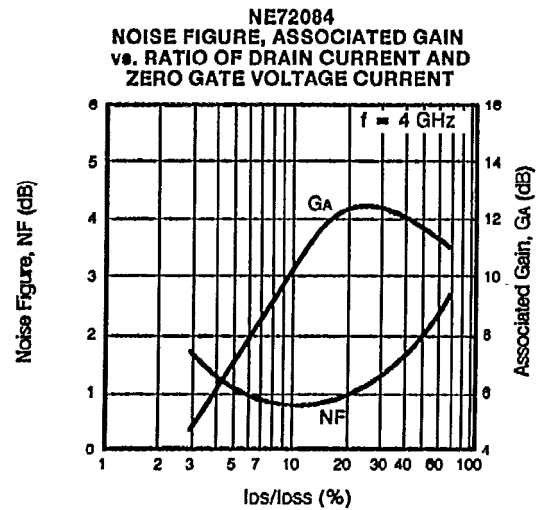
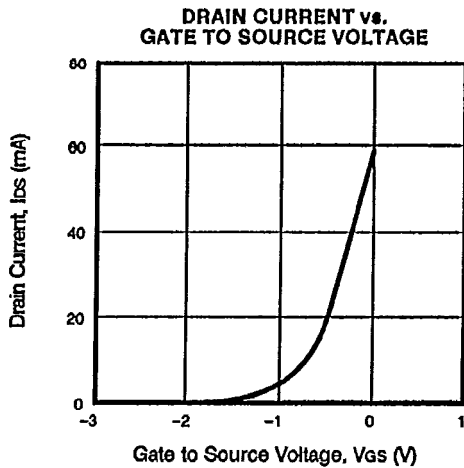
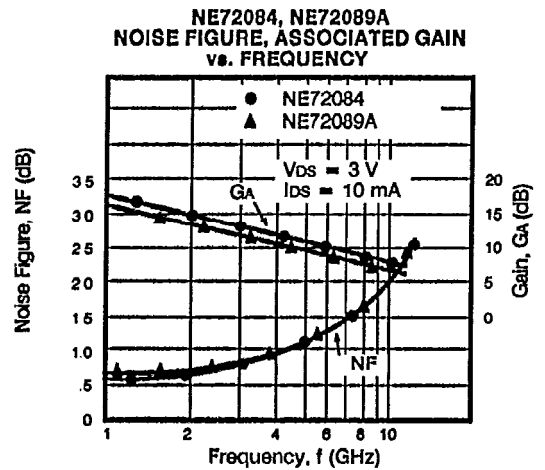
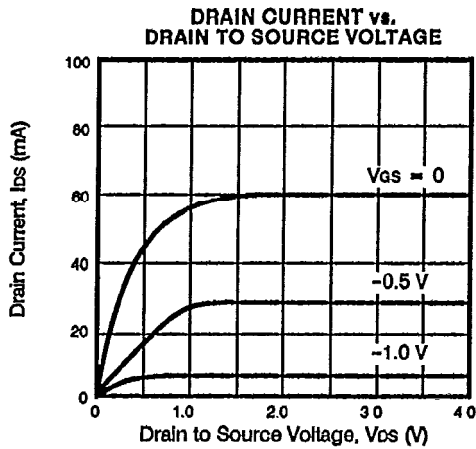
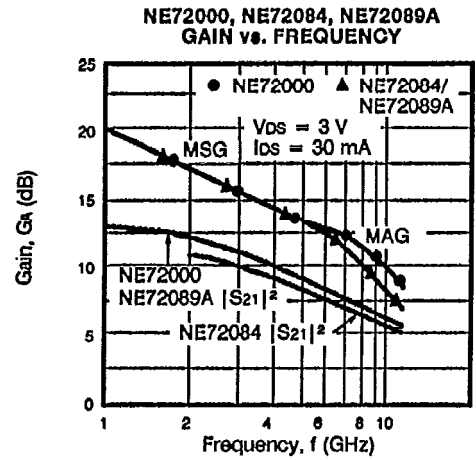
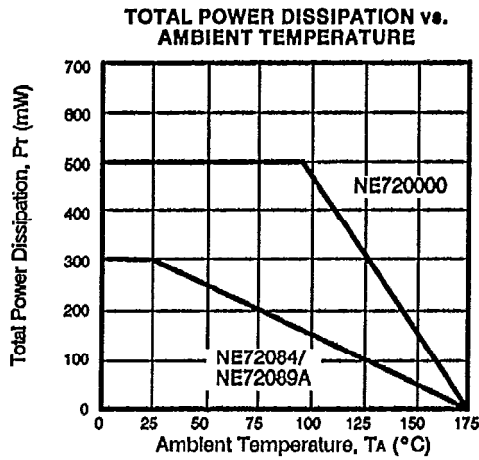

TYPICAL COMMON SOURCE SCATTERING PARAMETERS

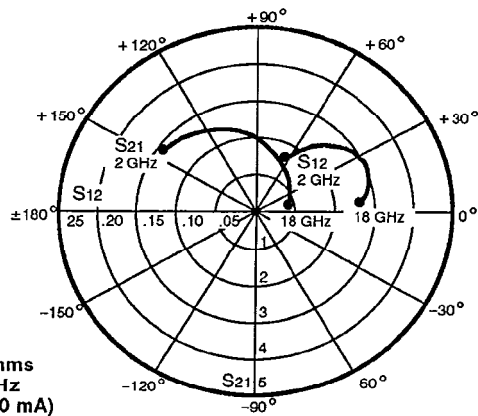
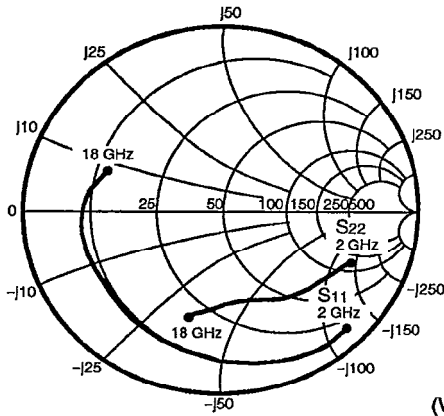

NE72000
Coordinates in Ohms
Frequency in GHz
(V_{DS} = 3 V, I_{DS} = 10 mA)

**S-MAGN AND ANGLES:
V_{DS} = 3 V, I_{DS} = 10 mA**

FREQUENCY (MHz)	S ₁₁		S ₂₁		S ₁₂		S ₂₂	
2000	.91	-44	2.95	144	.08	64	.71	-22
3000	.90	-63	2.81	132	.11	53	.68	-27
4000	.83	-81	2.47	113	.12	44	.62	-35
5000	.78	-96	2.27	105	.14	36	.58	-43
6000	.75	-108	2.08	97	.15	32	.56	-52
7000	.70	-119	1.83	87	.15	26	.55	-58
8000	.67	-130	1.65	79	.15	19	.55	-63
9000	.66	-140	1.49	72	.15	18	.56	-65
10000	.64	-152	1.37	64	.15	15	.56	-67
11000	.64	-158	1.24	59	.14	14	.54	-66
12000	.67	-165	1.18	54	.14	13	.54	-67
13000	.69	-168	1.11	49	.14	11	.51	-74
14000	.69	-175	1.11	44	.14	12	.54	-80
15000	.65	-178	.98	38	.13	9	.55	-86
16000	.66	174	1.02	33	.14	9	.53	-90
17000	.63	164	.96	26	.13	8	.56	-95
18000	.64	160	.86	21	.13	9	.50	-97

V_{DS} = 3 V, I_{DS} = 30 mA

2000	.90	-49	3.61	143	.07	62	.65	-24
3000	.89	-70	3.39	130	.10	52	.61	-28
4000	.83	-88	2.91	117	.11	44	.55	-36
5000	.78	-103	2.63	104	.12	36	.51	-44
6000	.75	-116	2.37	97	.13	33	.49	-53
7000	.70	-126	2.08	87	.13	27	.49	-59
8000	.68	-137	1.87	79	.13	22	.49	-64
9000	.67	-148	1.67	73	.13	21	.51	-67
10000	.65	-158	1.53	65	.12	19	.51	-68
11000	.65	-164	1.37	60	.12	18	.49	-67
12000	.70	-171	1.32	55	.12	18	.47	-68
13000	.72	-174	1.23	51	.12	17	.47	-75
14000	.74	-180	1.22	46	.13	20	.49	-81
15000	.67	177	1.09	40	.12	17	.50	-87
16000	.69	169	1.12	36	.12	18	.50	-90
17000	.66	158	1.05	28	.13	18	.52	-96
18000	.67	156	.94	24	.12	20	.56	-98

NE720 SERIES

TYPICAL COMMON SOURCE SCATTERING PARAMETERS

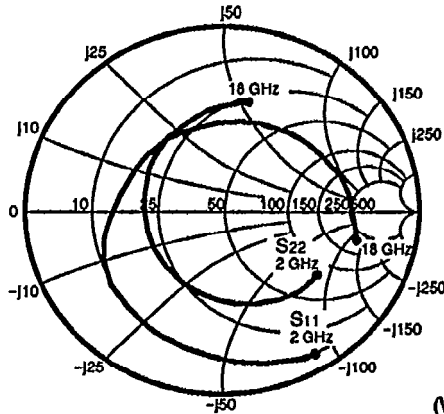

NE72084
Coordinates in Ohms
Frequency in GHz
(V_{DS} = 3 V, I_{DS} = 30 mA)

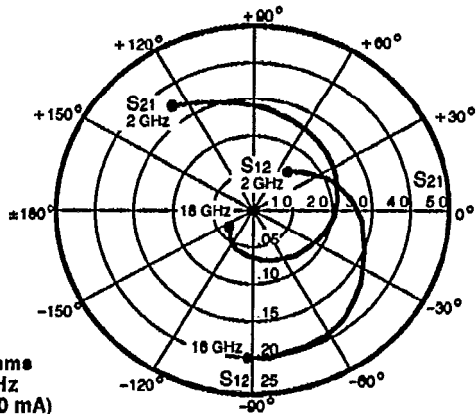

**S-MAGN AND ANGLES:
V_{DS} = 3 V, I_{DS} = 10 mA**

FREQUENCY (MHz)	S ₁₁		S ₂₁		S ₁₂		S ₂₂	
2000	.92	-54	2.91	130	.08	53	.69	-37
4000	.79	-102	2.47	85	.13	23	.61	-70
6000	.68	-141	2.19	49	.15	0	.54	-100
8000	.53	-177	1.82	15	.15	-16	.47	-126
10000	.47	136	1.68	-17	.16	-30	.43	-159
12000	.48	89	1.45	-51	.16	-45	.45	164
14000	.52	49	1.22	-82	.17	-62	.49	131
16000	.61	14	1.03	-115	.18	-82	.58	98
18000	.66	-5	.81	-138	.18	-98	.64	77

V_{DS} = 3 V, I_{DS} = 30 mA

2000	.91	-59	3.53	127	.07	54	.60	-37
4000	.76	-110	2.87	83	.10	28	.52	-69
6000	.65	-151	2.45	46	.12	8	.46	-97
8000	.52	171	2.02	14	.13	-4	.42	-122
10000	.49	124	1.82	-18	.15	-16	.38	-155
12000	.52	79	1.55	-50	.17	-31	.41	168
14000	.57	41	1.30	-82	.19	-51	.46	132
16000	.65	9	1.08	-114	.20	-74	.56	98
18000	.70	-10	.86	-136	.20	-91	.62	77

TYPICAL COMMON SOURCE SCATTERING PARAMETERS

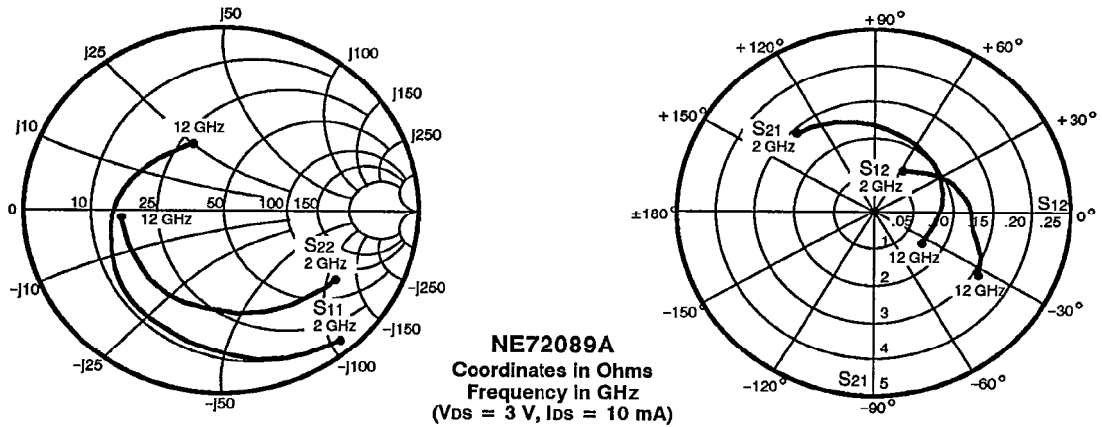

S-MAGN AND ANGLES:

V_{DS} = 3 V, I_{DS} = 10 mA

FREQUENCY (MHz)

	S ₁₁		S ₂₁		S ₁₂		S ₂₂	
2000	.92	-52	2.94	130	.07	54	.68	-35
3000	.84	-75	2.62	108	.09	38	.63	-51
4000	.76	-95	2.34	90	.11	26	.59	-66
5000	.71	-113	2.18	72	.12	16	.58	-79
6000	.65	-131	2.02	56	.13	7	.56	-93
7000	.59	-146	1.86	41	.13	-1	.54	-105
8000	.55	-160	1.76	26	.13	-7	.54	-116
9000	.49	-177	1.68	13	.13	-12	.53	-129
10000	.44	165	1.66	-1	.14	-17	.53	-139
11000	.39	140	1.63	-19	.15	-26	.52	-154
12000	.37	112	1.55	-34	.16	-33	.51	-170

V_{DS} = 3 V, I_{DS} = 30 mA

2000	.89	-58	3.76	127	.06	55	.60	-35
3000	.79	-82	3.27	105	.08	40	.56	-50
4000	.72	-103	2.88	86	.09	31	.53	-64
5000	.66	-121	2.61	69	.10	22	.51	-75
6000	.60	-139	2.38	54	.11	16	.50	-86
7000	.55	-155	2.18	38	.11	10	.50	-97
8000	.50	-170	2.04	24	.12	6	.50	-108
9000	.44	172	1.93	11	.12	2	.49	-118
10000	.40	152	1.89	-3	.14	-2	.50	-126
11000	.36	126	1.83	-20	.15	-11	.49	-138
12000	.35	99	1.72	-36	.16	-18	.48	-151

NE72084 TYPICAL NOISE PARAMETERS

FREQ. (GHz)	NF _{OPT} (dB)	G _A (dB)	Γ _{OPT}		R _n /50
			(MAG)	(ANG)	
1.0	0.55	17.5	0.90	15	0.52
2.0	0.60	14.5	0.81	38	0.49
4.0	1.00	11.5	0.74	59	0.39
6.0	1.30	9.5	0.66	102	0.30
8.0	1.70	8.6	0.49	130	0.24
10.0	2.15	7.5	0.32	172	0.18
12.0	2.50	6.5	0.26	-115	0.16
14.0	2.95	5.5	0.30	-54	0.13
16.0	3.30	4.7	0.26	-4	0.11
18.0	3.70	4.0	0.26	13	0.09

(V_{DS} = 3 V, I_{DS} = 10 mA)

NE72089A TYPICAL NOISE PARAMETERS

FREQ. (GHz)	NF _{OPT} (dB)	G _A (dB)	Γ _{OPT}		R _n /50
			(MAG)	(ANG)	
1.0	0.60	17.5	0.76	13	0.68
2.0	0.75	14.5	0.73	36	0.58
4.0	1.00	11.5	0.65	68	0.42
6.0	1.30	9.0	0.53	100	0.28
8.0	1.70	8.5	0.42	138	0.19
10.0	2.05	7.0	0.31	175	0.15
12.0	2.50	6.5	0.25	-117	0.25

(V_{DS} = 3 V, I_{DS} = 10 mA)

NE72000 EQUIVALENT CIRCUIT

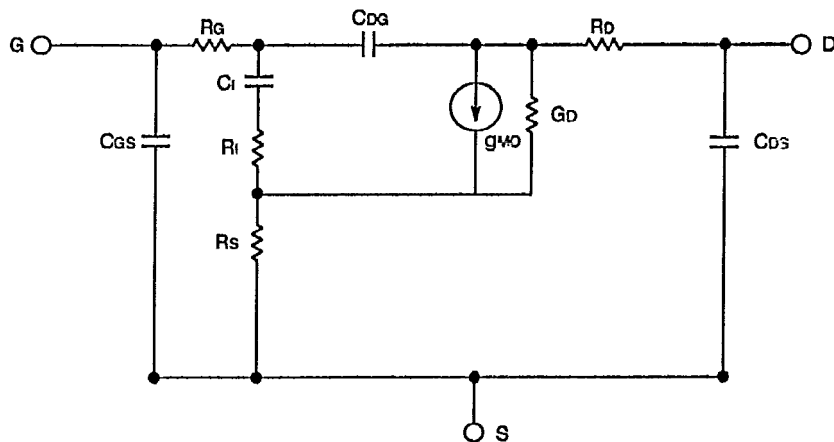

COMPONENT	VALUE
R _g	0.57 Ω
C _i	0.15 pF
R _i	2.00 Ω
R _s	2.00 Ω
C _{dg}	0.03 pF
R _d	2.00 Ω
C _{ds}	0.015 pF
g _{mo}	40.0 (mS)
G _d	2.0 (mS)
C _{gs}	0.55 pF