

Advance Information

SWITCHMODE™ Series

NPN Bipolar Power Transistor

The MJE8503A transistor is designed for high voltage, high speed, power switching in inductive circuits where fall time is critical. They are suited for line operated switchmode applications such as:

- Switching Regulators
- Inverters
- Solenoid and Relay Drivers
- Motor Controls
- Deflection Circuits

Featuring

- 1500 Volt Collector-Base Breakdown Capability
- Fast Switching:
 - 180 ns Typical Fall Times
 - 450 ns Typical Crossover Times
 - 1.2 μ s Typical Storage Times
- Low Collector-Emitter Leakage Current — 100 μ A Max @ 1500 V_{CES}

MJE8503A*

*Motorola Preferred Device

POWER TRANSISTORS
5.0 AMPERES
1500 VOLTS — V_{CES}
80 WATTS

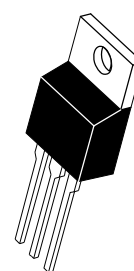

CASE 221A-06
TO-220AB

MAXIMUM RATINGS (T_C = 25°C unless otherwise noted)

Rating	Symbol	Value	Unit
Collector-Emitter Voltage	V _{CEO(sus)}	700	Vdc
Collector-Emitter Voltage	V _{CES}	1500	Vdc
Collector-Base Voltage	V _{CBO}	1500	Vdc
Emitter-Base Voltage	V _{EBO}	5.0	Vdc
Collector Current — Continuous — Peak (1)	I _C	5.0 10	Adc
Collector Current — Continuous — Peak	I _B I _{BM}	4.0 4.0	Adc
Total Power Dissipation @ T _C = 25°C @ T _C = 100°C Derate above 25°C	P _D	80 21 0.8	Watts W/°C
Operating and Storage Temperature Range	T _J , T _{stg}	-65 to +125	°C

THERMAL CHARACTERISTICS

Characteristic	Symbol	Max	Unit
Thermal Resistance, Junction to Case	R _{θJC}	1.25	°C/W
Maximum Lead Temperature for Soldering Purposes 1/8" from Case for 5 sec.	T _L	275	°C

(1) Pulse Test: Pulse Width = 5.0 ms, Duty Cycle < 10%.

SWITCHMODE is a trademark of Motorola Inc.

This document contains information on a new product. Specifications and information herein are subject to change without notice.

Preferred devices are Motorola recommended choices for future use and best overall value.



MJE8503A

ELECTRICAL CHARACTERISTICS (T_C = 25°C unless otherwise noted)

Characteristic	Symbol	Min	Typ	Max	Unit
OFF CHARACTERISTICS					
Collector-Emitter Sustaining Voltage (I _C = 100 mA _{dc} , I _B = 0)	V _{CEO(sus)}	700	—	—	V _{dc}
Collector Cutoff Current (V _{CE} = 1500 V _{dc} , V _{BE} = 0, T _C = 25°C) (V _{CE} = 1500 V _{dc} , V _{BE} = 0, T _C = 125°C)	I _{CES}	— —	— —	0.1 2.0	mA _{dc}
Collector Cutoff Current (V _{CE} = 1500 V _{dc} , R _{BE} = 50 Ohms, T _C = 100°C)	I _{CER}	—	—	5.0	mA _{dc}
Emitter Cutoff Current (V _{EB} = 6.0 V _{dc} , I _C = 0)	I _{EBO}	—	—	1.0	mA _{dc}

SECOND BREAKDOWN

Second Breakdown Collector with Base Forward Biased	I _{S/b}	See Figure 2			
---	------------------	--------------	--	--	--

ON CHARACTERISTICS

DC Current Gain (I _C = 1.0 A _{dc} , V _{CE} = 5.0 V _{dc}) (I _C = 4.5 A _{dc} , V _{CE} = 5.0 V _{dc})	h _{FE}	7.5 2.25	— —	— —	—
Base-Emitter Saturation Voltage (I _C = 2.5 A _{dc} , I _B = 1.0 V _{dc}) (I _C = 4.5 A _{dc} , I _B = 2.0 V _{dc})	V _{BE(sat)}	— —	— —	1.5 1.5	V _{dc}
Collector-Emitter Saturation Voltage (I _C = 2.5 A _{dc} , I _B = 1.0 V _{dc}) (I _C = 4.5 A _{dc} , I _B = 2.0 V _{dc})	V _{CE(sat)}	— —	— —	2.0 3.0	V _{dc}

DYNAMIC CHARACTERISTICS

Current-Gain — Bandwidth Product (I _C = 0.1 A _{dc} , V _{CE} = 5.0 V _{dc} , f _{test} = 1.0 MHz)	f _T	—	7.0	—	MHz
Output Capacitance (V _{CB} = 10 V _{dc} , I _E = 0, f _{test} = 0.1 MHz)	C _{ob}	—	125	—	pF

SWITCHING CHARACTERISTICS

Resistive Load (Table 1)						
Delay Time	(I _C = 2.5 A _{dc} , I _B = 1.0 A _{dc} , V _{CC} = 500 V _{dc} V _{BE(off)} = 5.0 V _{dc} , t _p = 50 μs)	t _d	—	0.06	0.2	μs
Rise Time		t _r	—	0.08	2.0	
Storage Time		t _s	—	1.2	4.0	
Fall Time		t _f	—	0.7	2.0	
Inductive Load (Table 1)						
Storage Time	(I _C = 2.5 A _{dc} , I _B = 1.0 A _{dc} , V _{clamp} = 500 V _{dc} V _{BE(off)} = 5.0 V _{dc} , t _p = 50 μs)	t _{sv}	—	1.2	—	μs
Crossover Time		t _c	—	0.45	—	
Fall Time		t _{fi}	—	0.18	—	

(1) Pulse Test: Pulse Width = 300 μs, Duty Cycle ≤ 2%

PACKAGE DIMENSIONS

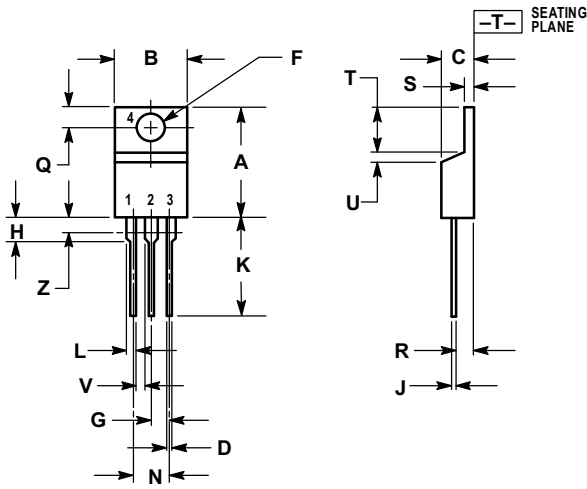

- NOTES:
1. DIMENSIONING AND TOLERANCING PER ANSI Y14.5M, 1982.
 2. CONTROLLING DIMENSION: INCH.
 3. DIMENSION Z DEFINES A ZONE WHERE ALL BODY AND LEAD IRREGULARITIES ARE ALLOWED.

DIM	INCHES		MILLIMETERS	
	MIN	MAX	MIN	MAX
A	0.570	0.620	14.48	15.75
B	0.380	0.405	9.66	10.28
C	0.160	0.190	4.07	4.82
D	0.025	0.035	0.64	0.88
F	0.142	0.147	3.61	3.73
G	0.095	0.105	2.42	2.66
H	0.110	0.155	2.80	3.93
J	0.018	0.025	0.46	0.64
K	0.500	0.562	12.70	14.27
L	0.045	0.060	1.15	1.52
N	0.190	0.210	4.83	5.33
Q	0.100	0.120	2.54	3.04
R	0.080	0.110	2.04	2.79
S	0.045	0.055	1.15	1.39
T	0.235	0.255	5.97	6.47
U	0.000	0.050	0.00	1.27
V	0.045	—	1.15	—
Z	—	0.080	—	2.04

- STYLE 1:
1. BASE
 2. COLLECTOR
 3. EMITTER
 4. COLLECTOR

CASE 221A-06
TO-220AB
ISSUE Y

Motorola reserves the right to make changes without further notice to any products herein. Motorola makes no warranty, representation or guarantee regarding the suitability of its products for any particular purpose, nor does Motorola assume any liability arising out of the application or use of any product or circuit, and specifically disclaims any and all liability, including without limitation consequential or incidental damages. "Typical" parameters can and do vary in different applications. All operating parameters, including "Typicals" must be validated for each customer application by customer's technical experts. Motorola does not convey any license under its patent rights nor the rights of others. Motorola products are not designed, intended, or authorized for use as components in systems intended for surgical implant into the body, or other applications intended to support or sustain life, or for any other application in which the failure of the Motorola product could create a situation where personal injury or death may occur. Should Buyer purchase or use Motorola products for any such unintended or unauthorized application, Buyer shall indemnify and hold Motorola and its officers, employees, subsidiaries, affiliates, and distributors harmless against all claims, costs, damages, and expenses, and reasonable attorney fees arising out of, directly or indirectly, any claim of personal injury or death associated with such unintended or unauthorized use, even if such claim alleges that Motorola was negligent regarding the design or manufacture of the part. Motorola and (AA) are registered trademarks of Motorola, Inc. Motorola, Inc. is an Equal Opportunity/Affirmative Action Employer.

How to reach us:

USA / EUROPE: Motorola Literature Distribution;
P.O. Box 20912; Phoenix, Arizona 85036. 1-800-441-2447

JAPAN: Nippon Motorola Ltd.; Tatsumi-SPD-JLDC, Toshikatsu Otsuki,
6F Seibu-Butsuryu-Center, 3-14-2 Tatsumi Koto-Ku, Tokyo 135, Japan. 03-3521-8315

MFAX: RMFAX0@email.sps.mot.com - TOUCHTONE (602) 244-6609
INTERNET: http://Design-NET.com

HONG KONG: Motorola Semiconductors H.K. Ltd.; 8B Tai Ping Industrial Park,
51 Ting Kok Road, Tai Po, N.T., Hong Kong. 852-26629298

