

System Basis Chip with Low Speed Fault Tolerant CAN Interface

An SBC device is a monolithic IC combining many functions repeatedly found in standard microcontroller-based systems, e.g., protection, diagnostics, communication, power, etc. The 33889 is an SBC having fully protected, fixed 5.0 V low drop-out regulator, with current limit, over-temperature pre-warning and reset.

An output drive with sense input is also provided to implement a second 5.0 V regulator using an external PNP. The 33889 has Normal, Standby, Stop and Sleep modes; an internally switched high-side power supply output with two wake-up inputs; programmable timeout or window watchdog, Interrupt, Reset, SPI input control, and a low-speed fault tolerant CAN transceiver, compatible with CAN 2.0 A and B protocols for module-to-module communications. The combination is an economical solution for power management, high-speed communication, and control in MCU-based systems.

Features

- VDD1: 5.0 V low drop voltage regulator, current limitation, overtemperature detection, monitoring and reset function with total current capability 200 mA
- V₂: tracking function of VDD1 regulator; control circuitry for external bipolar ballast transistor for high flexibility in choice of peripheral voltage and current supply
- Four operational modes
- Low standby current consumption in Stop and Sleep modes
- Built-in low speed 125 kbps fault tolerant CAN physical interface.
- External high voltage wake-up input, associated with HS1 VBAT switch
- 150 mA output current capability for HS1 VBAT switch allowing drive of external switches pull-up resistors or relays
- Pb-Free Packaging Designated by Suffix Code EG

33889

SYSTEM BASIS CHIP



ORDERING INFORMATION		
Device	Temperature Range (T _A)	Package
MC33889BDW/R2	-40°C to 125°C	28 SOICW
MCZ33889BEG/R2		
MC33889DDW/R2		
*MCZ33889DEG/R2		

*Recommended for new designs

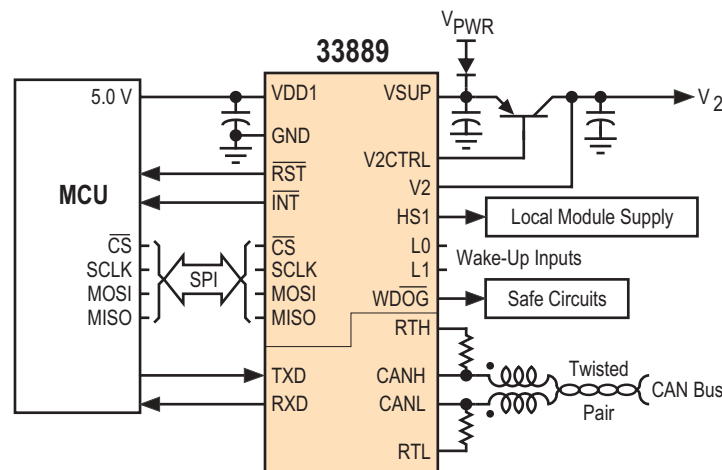

Figure 1. 33889 Simplified Application Diagram

Freescale Semiconductor, Inc. reserves the right to change the detail specifications, as may be required, to permit improvements in the design of its products.

© Freescale Semiconductor, Inc., 2007. All rights reserved.

DEVICE VARIATIONS

Table 1. Device Variations Between the 33889D and 33889B Versions ⁽¹⁾

Parameters	Symbol	Trait	Device Part Number	
			MC33889B ⁽²⁾	MC33889D ⁽²⁾
Differential Receiver, Recessive To Dominant Threshold (By Definition, $V_{DIFF} = V_{CANH} - V_{CANL}$)	V_{DIFF1}	Min	3.2 V	3.5 V
		Typ	2.6 V	3.0 V
		Max	2.1 V	2.5 V
Differential Receiver, Dominant To Recessive Threshold (Bus Failures 1, 2, 5)	V_{DIFF2}	Min	3.2 V	3.5 V
		Typ	2.6 V	3.0 V
		Max	2.1 V	2.5 V
CANH Output Current ($V_{CANH} = 0$; TX = 0.0)	I_{CANH}	Min	50 mA	50 mA
		Typ	75 mA	100 mA
		Max	110 mA	130 mA
CANL Output Current ($V_{CANL} = 14$ V; TX = 0.0)	I_{CANL}	Min	50 mA	50 mA
		Typ	90 mA	140 mA
		Max	135 mA	170 mA
Detection threshold for Short circuit to Battery voltage	Vcanh	max	$V_{sup}/2 + 5V$	$V_{sup}/2 + 4.55V$
loop time Tx to Rx, no bus failure, ISO configuration	tLOOPRD	max	N/A	1.5us
loop time Tx to Rx, with bus failure, ISO configuration	tLOOPRD-F	max	N/A	1.9us
loop time Tx to Rx, with bus failure and +-1.5V gnd shift, 5 node network, ISO configuration	tLOOPRD/DR-F+GS		N/A	3.6us
Minimum Dominant time for Wake up on CANL or CANH (Term Vbat mode)	tWAKE	min	N/A	8
		typ	30	16
		max	N/A	30
T2SPI timing	T2spi	min	not specified, 25us spec applied	25us

DEVICE BEHAVIOR

CANH or CANL open wire recovery principle	Reference MC33889B: on page 33	after 4 non consecutive pulses	after 4 consecutive pulses
Rx behavior in TermVbat mode	Reference MC33889D: on page 34	Rx recessive, no pulse	Rx recessive, dominant pulse to signal bus traffic

Notes

1. This datasheet uses the term 33889 in the inclusive sense, referring to both the D version (33889D) and the B version (33889B).
2. The 33889D and 33889B versions are nearly identical. However, where variations in characteristic occur, these items will be separated onto individual lines.

INTERNAL BLOCK DIAGRAM

33889 Internal Block Diagram

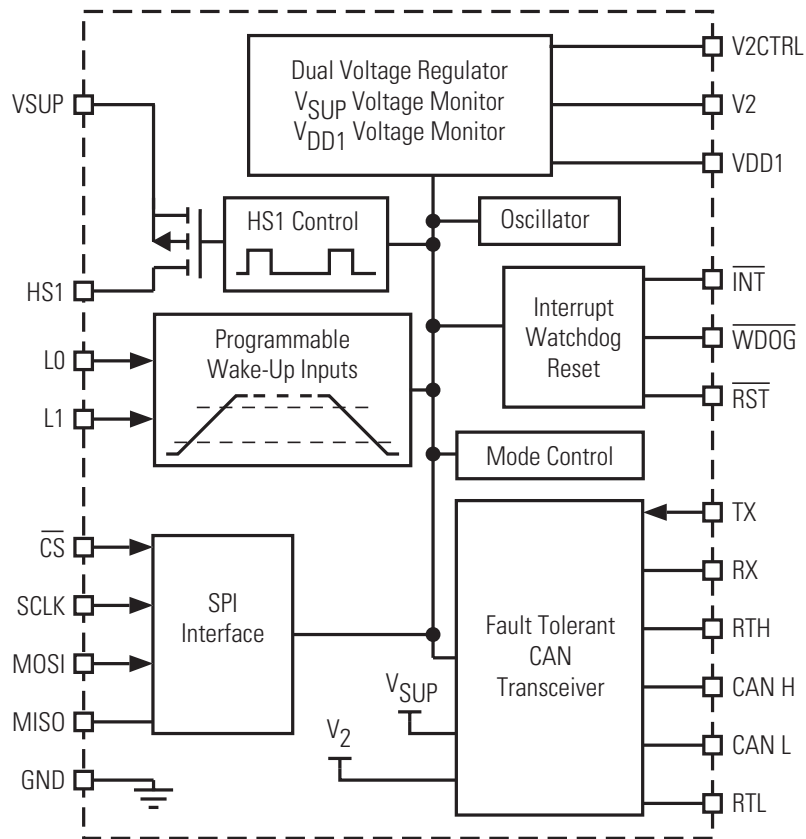

PIN CONNECTIONS

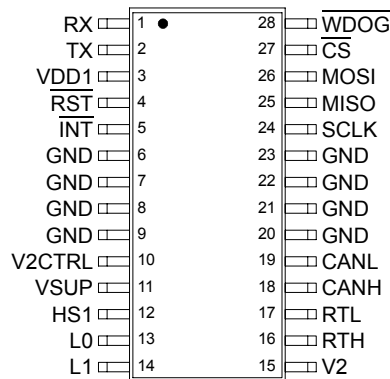

Figure 2. 33889 Pin Connections

Table 2. Pin Definitions

A functional description of each pin can be found in the [Functional pin description](#) section page [24](#).

Pin	Pin Name	Pin Function	Formal Name	Definition
1	RX	Output	Receiver Data	CAN bus receive data output pin
2	TX	Input	Transmitter Data	CAN bus receive data input pin
3	VDD1	Power Output	Voltage Regulator One	5.0 V pin is a 2% low drop voltage regulator for to the microcontroller supply.
4	$\overline{\text{RST}}$	Output	Reset	This is the device reset output pin whose main function is to reset the MCU.
5	$\overline{\text{INT}}$	Output	Interrupt	This output is asserted LOW when an enabled interrupt condition occurs.
6 - 9, 20 - 23	GND	Ground	Ground	These device ground pins are internally connected to the package lead frame to provide a 33889-to-PCB thermal path.
10	V2CTRL	Output	Voltage Source 2 Control	Output drive source for the V2 regulator connected to the external series pass transistor.
11	VSUP	Power Input	Voltage Supply	Supply input pin.
12	HS1	Output	High-Side Output	Output of the internal high-side switch.
13 - 14	L0, L1	Input	Level 0 - 1 Inputs	Inputs from external switches or from logic circuitry.
15	V2	Input	Voltage Regulator Two	5.0 V pin is a low drop voltage regulator dedicated to the peripherals supply.
16	RTH	Output	RTH	Pin for connection of the bus termination resistor to CANH.
17	RTL	Output	RTL	Pin for connection of the bus termination resistor to CANL.
18	CANH	Output	CAN High	CAN high output pin.
19	CANL	Output	CAN Low	CAN low output pin.
24	SCLK	Input	System Clock	Clock input pin for the Serial Peripheral Interface (SPI).

Table 2. Pin Definitions (continued)

A functional description of each pin can be found in the [Functional pin description](#) section page [24](#).

Pin	Pin Name	Pin Function	Formal Name	Definition
25	MISO	Output	Master In/Slave Out	SPI data sent to the MCU by the 33889. When CS _{LOW} is HIGH, the pin is in the high impedance state.
26	MOSI	Input	Master Out/Slave In	SPI data received by the 33889.
27	$\overline{\text{CS}}$	Input	Chip Select	The CS _{LOW} input pin is used with the SPI bus to select the 33889. When the CS _{LOW} is asserted LOW, the 33889 is the selected device of the SPI bus.
28	$\overline{\text{WDOG}}$	Output	Watchdog	The WDOG output pin is asserted LOW if the software watchdog is not correctly triggered.

ELECTRICAL CHARACTERISTICS

MAXIMUM RATINGS

Table 3. Maximum Ratings

All voltages are with respect to ground unless otherwise noted. Exceeding these ratings may cause a malfunction or permanent damage to the device.

Ratings	Symbol	Max	Unit
ELECTRICAL RATINGS			
Supply Voltage at VSUP Continuous voltage Transient voltage (Load dump)	V _{SUP}	-0.3 to 27 40	V
Logic Signals (RX, TX, MOSI, MISO, $\overline{\text{CS}}$, SCLK, $\overline{\text{RST}}$, $\overline{\text{WDOG}}$, $\overline{\text{INT}}$)	V _{LOG}	-0.3 to V _{DD1} +0.3	V
Output current VDD1	I	Internally Limited	mA
HS1 Voltage Output Current	V I	-0.2 to V _{SUP} +0.3 Internally Limited	V A
L0, L1 DC Input voltage DC Input current Transient input voltage (according to ISO7637 specification) and with external component per Figure 3 .	V _{WU} I _{WU} V _{TRWU}	-0.3 to 40 -2.0 to 2.0 +100	V mA V
DC voltage at V2 (V2INT)	V _{2INT}	0 to 5.25	V
DC Voltage On Pins CANH, CANL	V _{BUS}	-20 to +27	V
Transient Voltage At Pins CANH, CANL 0.0 < V2-INT < 5.5 V; VSUP = 0.0; T < 500 ms	V _{CANH} /V _{CANL}	-40 to +40	V
Transient Voltage On Pins CANH, CANL (Coupled Through 1.0 nF Capacitor)	V _{TR}	-150 to +100	V
DC Voltage On Pins RTH, RTL	V _{RTL} , V _{RTH}	-0.3 to +27V	V
Transient Voltage At Pins RTH, RTL 0.0 < V2-INT < 5.5 V; VSUP = 0.0; T < 500 ms	V _{RTH} /V _{RTL}	-0.3 to +40	V

Table 3. Maximum Ratings (continued)

All voltages are with respect to ground unless otherwise noted. Exceeding these ratings may cause a malfunction or permanent damage to the device.

Ratings	Symbol	Max	Unit
ESD voltage (HBM 100 pF, 1.5 k) ⁽³⁾ CANL, CANH, HS1, L0, L1 RTH, RTL All other pins	V_{ESDH}	±4.0 ±3.0 ±2.0	kV
ESD voltage (Machine Model) All pins, MC33889B ^{(3) (4)}	V_{ESD-MM}	±200	V
ESD voltage (CDM) All pins, MC33889D ⁽⁴⁾ Pins 1,14,15, & 28 All other pins	$V_{ESD-CDM}$	750 500	V
RTH, RTL Termination Resistance	R_T	500 to 16000	ohms

THERMAL RATINGS

Junction Temperature	T_J	-40 to 150	°C
Storage Temperature	T_S	-55 to 165	°C
Ambient Temperature (for info only)	T_A	-40 to 125	°C
Thermal resistance junction to gnd pin ⁽⁵⁾	$R_{THJ/P}$	20	°C/W

Notes:

3. Testing done in accordance with the Human Body Model (CZAP=100 pF, RZAP=1500), Machine Model (CZAP=200 pF, RZAP=0).
4. ESD machine model (MM) is for MC33889B only. MM is now replaced by CDM (Charged Discharged model).
5. Gnd pins 6,7,8,9,20, 21, 22, 23.

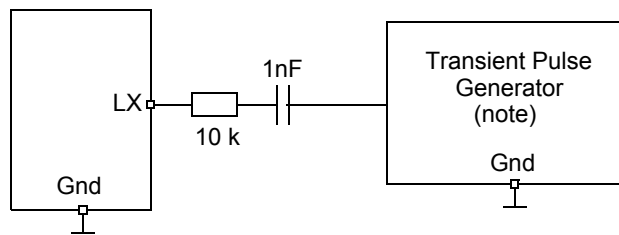

Note: Waveform in accordance to ISO7637 part1, test pulses 1, 2, 3a and 3b.

Figure 3. Transient test pulse for L0 and L1 inputs

STATIC ELECTRICAL CHARACTERISTICS

Table 4. Static Electrical Characteristics .

Characteristics noted under conditions - V_{SUP} From 5.5 V to 18 V and T_J from -40°C to 125°C , unless otherwise noted. Typical values noted reflect the approximate parameter means at $T_A = 25^{\circ}\text{C}$ under nominal conditions unless otherwise noted.

Description	Symbol	Min	Typ	Max	Unit
INPUT PIN (VSUP)					
Nominal DC Voltage range	V_{SUP}	5.5	-	18	V
Extended DC Voltage range 1 Reduced functionality ⁽⁶⁾	$V_{SUP-EX1}$	4.5	-	5.5	V
Extended DC Voltage range 2 ⁽⁸⁾	$V_{SUP-EX2}$	18	-	27	V
Input Voltage during Load Dump Load dump situation	V_{SUPLD}	-	-	40	V
Input Voltage during jump start Jump start situation	V_{SUPJS}	-	-	27	V
Supply Current in Sleep Mode ⁽⁷⁾ V_{DD1} & V_2 off, $V_{SUP} \leq 12$ V, oscillator running ⁽¹⁰⁾	I_{SUP} (SLEEP1)	-	95	130	μA
Supply Current in Sleep Mode ⁽⁷⁾ V_{DD1} & V_2 off, $V_{SUP} \leq 12$ V, oscillator not running	I_{SUP} (SLEEP2)	-	55	90	μA
Supply current in sleep mode ⁽⁷⁾ V_{DD1} & V_2 off, $V_{SUP} = 18$ V, oscillator running ⁽¹⁰⁾	I_{SUP} (SLEEP3)	-	170	270	μA
Supply Current in Stand-by Mode ^{(7),(9)} Iout at $V_{DD1} = 40$ mA, CAN recessive state or disabled	$I_{SUP(STDBY)}$	-	42	45	mA
Supply Current in Normal Mode ⁽⁷⁾ Iout at $V_{DD1} = 40$ mA, CAN recessive state or disabled	$I_{SUP(NORM)}$	-	42.5	45	mA
Supply Current in Stop mode ^{(7),(9)} Iout $V_{DD1} < 2.0$ mA, V_{DD1} on ⁽¹¹⁾ , $V_{SUP} \leq 12$ V, oscillator running ⁽¹⁰⁾	I_{SUP} (STOP1)	-	120	150	μA
Supply Current in Stop mode ^{(7),(9)} Iout $V_{DD1} < 2.0$ mA, V_{DD1} on ⁽¹¹⁾ $V_{SUP} \leq 12$ V, oscillator not running ⁽¹⁰⁾	I_{SUP} (STOP2)	-	80	110	μA
Supply Current in Stop mode ^{(7),(9)} Iout $V_{DD1} < 2.0$ mA, V_{DD1} on ⁽¹¹⁾ , $V_{SUP} = 18$ V, oscillator running ⁽¹⁰⁾	I_{SUP} (STOP3)	-	200	285	μA

Notes

6. $V_{DD1} > 4.0$ V, reset high, if R_{STTH-2} selected and I_{OUT} V_{DD1} reduced, logic pin high level reduced, device is functional.
7. Current measured at V_{SUP} pin.
8. Device is fully functional. All modes available and operating, Watchdog, HS1 turn ON turn OFF, CAN cell operating, L0 and L1 inputs operating, SPI read write operation. Over temperature may occur.
9. Measured in worst case condition with 5.0 V at V_2 pin (V_2 pin tied to V_{DD1}).
10. Oscillator running means "Forced Wake-Up" or "Cyclic Sense" or "Software Watchdog" timer activated. Software Watchdog is available in stop mode only.
11. V_{DD1} is ON with 2.0 mA typical output current capability.

Table 4. Static Electrical Characteristics (continued).

Characteristics noted under conditions - V_{SUP} From 5.5 V to 18 V and T_J from -40°C to 125°C , unless otherwise noted. Typical values noted reflect the approximate parameter means at $T_A = 25^{\circ}\text{C}$ under nominal conditions unless otherwise noted.

Description	Symbol	Min	Typ	Max	Unit
Supply Fail Flag internal threshold	V_{THRESH}	1.5	3.0	4.0	V
Supply Fail Flag hysteresis ⁽¹²⁾	$V_{DETHYST}$	-	1.0	-	V
Battery fall early warning threshold In normal & standby mode	BF_{EW}	5.8	6.1	6.4	V
Battery fall early warning hysteresis In normal & standby mode ⁽¹²⁾	BF_{EWH}	0.1	0.2	0.3	V

OUTPUT PIN (VDD1) ⁽¹³⁾

VDD1 Output Voltage I_{DD1} from 2.0 to 200mA $5.5\text{ V} < V_{SUP} < 27\text{ V}$ $4.5\text{ V} < V_{SUP} < 5.5\text{ V}$	V_{DD1OUT}	4.9 4.0	5.0 -	5.1 -	V
Drop Voltage $V_{SUP} > V_{DDOUT}$ $I_{DD1} = 200\text{ mA}$	$V_{DD1DROP}$	-	0.2	0.5	V
Drop Voltage $V_{SUP} > V_{DDOUT}$, limited output current $I_{DD1} = 50\text{ mA}$ $4.5\text{ V} < V_{SUP} < 27\text{ V}$	V_{DD1DP2}	-	0.1	0.25	V
I_{DD1} Output Current Internally limited	I_{DD1}	200	270	350	mA
VDD1 Output Voltage in stop mode $I_{out} < 2.0\text{ mA}$	V_{DDSTOP}	4.75	5.00	5.25	V
I_{DD1} stop output current to wake-up SBC Default value after reset. ⁽¹⁴⁾	$I_{DD1S-WU1}$	2.0	3.5	6.0	mA
I_{DD1} stop output current to wake-up SBC ⁽¹⁴⁾	$I_{DD1S-WU2}$	10	14	18	mA
I_{DD1} over current wake deglitcher (with $I_{DD1S-WU1}$ selected) ⁽¹²⁾	$I_{DD1-DGIT11}$	40	55	75	μs
I_{DD1} over current wake deglitcher (with $I_{DD1S-WU2}$ selected) ⁽¹²⁾	$I_{DD1-DGIT2}$	-	150	-	μs
Thermal Shutdown Normal or standby mode	T_{SD}	160	-	190	$^{\circ}\text{C}$
Over temperature pre warning VDDTEMP bit set	T_{PW}	130	-	160	$^{\circ}\text{C}$
Temperature Threshold difference	$T_{SD}-T_{PW}$	20	-	40	$^{\circ}\text{C}$

Notes

12. Guaranteed by design
13. I_{DD1} is the total regulator output current. VDD specification with external capacitor $C \geq 22\mu\text{F}$ and $\text{ESR} < 10\text{ ohm}$.
14. Selectable by SPI

Table 4. Static Electrical Characteristics (continued).

Characteristics noted under conditions - V_{SUP} From 5.5 V to 18 V and T_J from -40°C to 125°C , unless otherwise noted. Typical values noted reflect the approximate parameter means at $T_A = 25^{\circ}\text{C}$ under nominal conditions unless otherwise noted.

Description	Symbol	Min	Typ	Max	Unit
Reset threshold 1 Default value after reset. ⁽¹⁵⁾	$V_{RST-TH1}$	4.5	4.6	4.7	V
Reset threshold 2 ⁽¹⁵⁾	$V_{RST-TH2}$	4.1	4.2	4.3	V
Reset duration	RESET-DUR	0.85	1.0	2.0	ms
VDD1 range for Reset Active	V_{DD}	1.0	-	-	V
Reset Delay Time Measured at 50% of reset signal. ⁽¹⁶⁾	t_D	5.0	-	20	μs
Line Regulation $9.0\text{ V} < V_{SUP} < 18$, $I_{DD} = 10\text{ mA}$	LR1	-	5.0	25	mV
Line Regulation $5.5\text{ V} < V_{SUP} < 27\text{ V}$, $I_{DD} = 10\text{ mA}$	LR2	-	10	25	mV
Load Regulation $1\text{ mA} < I_{DD} < 200\text{ mA}$	LD	-	25	75	mV
Thermal stability $V_{SUP} = 13.5\text{ V}$, $I = 100\text{ mA}$	THERMS	-	5.0	-	mV

V2 REGULATOR (V2) ⁽¹⁷⁾

V2 Output Voltage I_2 from 2.0 to 200 mA $5.5\text{ V} < V_{SUP} < 27\text{ V}$	V2	0.99	1.0	1.01	V_{DD1}
I_2 output current (for information only) Depending on the external ballast transistor	I_2	200	-	-	mA
V2 CTRL sink current capability	I_{2CTRL}	10	-	-	mA
V2LOW flag threshold	V_{2LTH}	3.75	4.0	4.25	V
Internal V2 Supply Current (CAN and SBC in Normal Mode). TX = 5.0 V, CAN in Recessive State	I_{V2RS}	3.8	5.6	6.8	mA
Internal V2 Supply Current (CAN and SBC in Normal Mode). TX = 0.0 V, No Load, CAN in Dominant State	I_{V2DS}	4.0	5.8	7.0	mA
Internal V2 Supply Current (CAN in Receive Only Mode, SBC in Normal mode). $V_{SUP} = 12\text{ V}$	I_{V2R}		80	120	μA
Internal V2 Supply Current (CAN in Bus TermVbat mode, SBC in normal mode), $V_{SUP} = 12\text{ V}$	I_{V2BT}		35	60	μA

Notes

15. Selectable by SPI
16. Guaranteed by design
17. **V2 TRACKING VOLTAGE REGULATOR** - V2 specification with external capacitor
 - option 1: $C \geq 22\ \mu\text{F}$ and $\text{ESR} < 10\ \text{ohm}$. Using a resistor of 2 kohm or less between the base and emitter of the external PNP is recommended.
 - option2: $1.0\ \mu\text{F} < C < 22\ \mu\text{F}$ and $\text{ESR} < 10\ \text{ohm}$. In this case depending on the ballast transistor gain an additional resistor and capacitor network between emitter and base of PNP ballast transistor might be required. Refer to Freescale application information or contact your local technical support.
 - option 3: $10\ \mu\text{F} < C < 22\ \mu\text{F}$ $\text{ESR} > 0.2\ \text{ohms}$: a resistor of 2 kohm or less is required between the base and emitter of the external PNP.

Table 4. Static Electrical Characteristics (continued).

Characteristics noted under conditions - V_{SUP} From 5.5 V to 18 V and T_J from -40°C to 125°C , unless otherwise noted. Typical values noted reflect the approximate parameter means at $T_A = 25^{\circ}\text{C}$ under nominal conditions unless otherwise noted.

Description	Symbol	Min	Typ	Max	Unit
LOGIC OUTPUT PINS (MISO)					
Low Level Output Voltage $I_{OUT} = 1.5 \text{ mA}$	V_{OL}	-	-	1.0	V
High Level Output Voltage $I_{OUT} = -250 \mu\text{A}$	V_{OH}	$V_{DD1}-0.9$	-	-	V
Tri-state MISO Leakage Current $0.0 \text{ V} < V_{MISO} < V_{DD}$	I_{HZ}	-2.0	-	+2.0	μA
LOGIC INPUT PINS (MOSI, SCLK, $\overline{\text{CS}}$)					
High Level Input Voltage	V_{IH}	$0.7V_{DD1}$	-	$V_{DD1}+0.3\text{V}$	
Low Level Input Voltage	V_{IL}	-0.3	-	$0.3 V_{DD1}$	V
Input Current on $\overline{\text{CS}}$ $V_I = 4.0 \text{ V}$ $V_I = 1.0 \text{ V}$	I_{IH} I_{IL}	-100	-	-20	μA
Low Level Input Current $\overline{\text{CS}}$ $V_I = 1.0 \text{ V}$	I_{IL}	-100	-	-20	μA
MOSI, SCLK Input Current $0.0 < V_{IN} < V_{DD}$	I_{IN}	-10	-	10	μA
RESET PIN ($\overline{\text{RST}}$)					
High Level Output current $0.0 < V_{out} < 0.7 V_{DD}$	I_{OH}	-350	-250	-150	μA
Low Level Output Voltage ($I_0 = 1.5 \text{ mA}$) $5.5 \text{ V} < V_{SUP} < 27 \text{ V}$ $1.0 \text{ V} < V_{DD1}$	V_{OL}	0.0 0.0	- -	0.9 0.9	V
Reset pull down current	I_{PDW}	2.3	-	5.0	mA
WATCHDOG PIN ($\overline{\text{WDOG}}$)					
Low Level Output Voltage ($I_0 = 1.5 \text{ mA}$) $5.5 \text{ V} < V_{SUP} < 27 \text{ V}$	V_{OL}	0.0	-	0.9	V
High Level Output Voltage ($I_0 = -250 \mu\text{A}$)	V_{OH}	$V_{DD1} - 0.9$	-	V_{DD1}	V
INTERRUPT PIN ($\overline{\text{INT}}$)					
Low Level Output Voltage ($I_0 = 1.5 \text{ mA}$)	V_{OL}	0.0	-	0.9	V
High Level Output Voltage ($I_0 = -250 \mu\text{A}$)	V_{OH}	$V_{DD1} - 0.9$	-	V_{DD1}	V
HIGH-SIDE OUTPUT PIN (HS1)					
$R_{DS(ON)}$ at $T_J = 25^{\circ}\text{C}$, and $I_{OUT} = -150 \text{ mA}$ $V_{SUP} > 9\text{V}$	$R_{DS(ON)25}$	-	-	2.5	Ohms

Table 4. Static Electrical Characteristics (continued).

Characteristics noted under conditions - V_{SUP} From 5.5 V to 18 V and T_J from -40°C to 125°C , unless otherwise noted. Typical values noted reflect the approximate parameter means at $T_A = 25^{\circ}\text{C}$ under nominal conditions unless otherwise noted.

Description	Symbol	Min	Typ	Max	Unit
$R_{DS(ON)}$ at $T_J = 125^{\circ}\text{C}$, and $I_{OUT} = -150\text{ mA}$ $V_{SUP} > 9.0\text{ V}$	$R_{DS(ON)125}$	-	-	5.0	Ohms
$R_{DS(ON)}$ at $T_J = 125^{\circ}\text{C}$, and $I_{OUT} = -120\text{ mA}$ $5.5\text{ V} < V_{SUP} < 9.0\text{ V}$	$R_{DS(ON)125-2}$	-	4.0	5.5	Ohms
Output current limitation	I_{LIM}	160	-	500	mA
Over temperature Shutdown	O_{VT}	155	-	190	$^{\circ}\text{C}$
Leakage current	I_{LEAK}	-	-	10	μA
Output Clamp Voltage at $I_{OUT} = -1.0\text{ mA}$ ⁽¹⁸⁾ no inductive load drive capability	V_{CL}	-1.5	-	-0.3	V

INPUT PINS (L0 AND L1)

L0 Negative Switching Threshold $5.5\text{ V} < V_{SUP} < 6.0\text{ V}$ $6.0\text{ V} < V_{SUP} < 18\text{ V}$ $18\text{ V} < V_{SUP} < 27\text{ V}$	V_{TH0N}	1.7 2.0 2.0	2.0 2.4 2.5	3.0 3.0 3.1	V
L0 Positive Switching Threshold $5.5\text{ V} < V_{SUP} < 6.0\text{ V}$ $6.0\text{ V} < V_{SUP} < 18\text{ V}$ $18\text{ V} < V_{SUP} < 27\text{ V}$	V_{TH0P}	2.2 2.5 2.5	2.75 3.4 3.5	4.0 4.0 4.1	V
L1 Negative Switching Threshold $5.5\text{ V} < V_{SUP} < 6.0\text{ V}$ $6.0\text{ V} < V_{SUP} < 18\text{ V}$ $18\text{ V} < V_{SUP} < 27\text{ V}$	V_{TH1N}	2.0 2.5 2.7	2.5 3.0 3.2	3.0 3.7 3.8	V
L1 Positive Switching Threshold $5.5\text{ V} < V_{SUP} < 6.0\text{ V}$ $6.0\text{ V} < V_{SUP} < 18\text{ V}$ $18\text{ V} < V_{SUP} < 27\text{ V}$	V_{TH1P}	2.7 3.0 3.5	3.3 4.0 4.2	3.8 4.7 4.8	V
Hysteresis $5.5\text{ V} < V_{SUP} < 27\text{ V}$	V_{HYST}	0.6	1.0	1.3	V
Input current $-0.2\text{ V} < V_{IN} < 40\text{ V}$	I_{IN}	-10	-	10	μA

CAN MODULE SPECIFICATION (TX, RX, CANH, CANL, RTH, AND RTL)

DC Voltage On Pins TX, RX	V_{LOGIC}	-0.3		$V_{DD1} + 0.3$	V
DC voltage at V2 (V2INT)	V_{2INT}	0.0		5.25	V
DC Voltage On Pins CANH, CANL	V_{BUS}	-20		+27	V

Notes

18. Refer to HS1 negative maximum rating voltage limitation of -0.2V.

Table 4. Static Electrical Characteristics (continued).

Characteristics noted under conditions - V_{SUP} From 5.5 V to 18 V and T_J from -40°C to 125°C , unless otherwise noted. Typical values noted reflect the approximate parameter means at $T_A = 25^{\circ}\text{C}$ under nominal conditions unless otherwise noted.

Description	Symbol	Min	Typ	Max	Unit
Transient Voltage At Pins CANH, CANL $0.0 < V_{2-INT} < 5.5 \text{ V}; V_{SUP} \geq 0.0; T < 500 \text{ ms}$	V_{CANH}/V_{CANL}	-40		40	V
Transient Voltage On Pins CANH, CANL (Coupled Through 1.0 nF Capacitor)	V_{TR}	-150		100	V
Detection Threshold For Short-circuit To Battery Voltage (Term VBAT Mode) MC33889B	V_{CANH}	$V_{SUP}/2+3$		$V_{SUP}/2+5$	V
Detection Threshold For Short-circuit To Battery Voltage (Term VBAT Mode) MC33889D	V_{CANH}	$V_{SUP}/2+3$		$V_{SUP}/2+4.55$	V
DC Voltage On Pins RTH, RTL	V_{RTL}, V_{RTH}	-0.3		+27	V
Transient Voltage At Pins RTH, RTL $0.0 < V_{2-INT} < 5.5 \text{ V}; V_{SUP} \geq 0.0; T < 500 \text{ ms}$	V_{RTH}/V_{RTL}	-0.3		40	V

TRANSMITTER DATA PIN (TX)

High Level Input Voltage	V_{IH}	$0.7 \cdot V_2$		$V_2+0.3\text{V}$	V
Low Level Input Voltage	V_{IL}	-0.3		$0.3 \cdot V_2$	V
TX High Level Input Current ($V_1 = 4.0 \text{ V}$)	I_{TXH}	-100	-50	-25	μA
TX Low Level Input Current ($V_1 = 1.0 \text{ V}$)	I_{TXL}	-100	-50	-25	μA

RECEIVE DATA PIN (RX)

High Level Output Voltage RX ($I_O = -250 \mu\text{A}$)	V_{OH}	$V_{2-INT} - 0.9$		V_{2-INT}	V
Low Level Output Voltage ($I_O = 1.5 \text{ mA}$)	V_{OL}	0.0		0.9	V

CAN HIGH AND CAN LOW PINS (CANH, CANL)

Differential Receiver, Recessive To Dominant Threshold (By Definition, $V_{DIFF} = V_{CANH} - V_{CANL}$) For 33889D For 33889B	V_{DIFF1}	-3.5 -3.2	-3.0 -2.6	-2.5 -2.1	V
Differential Receiver, Dominant To Recessive Threshold (Bus Failures 1, 2, 5) For 33889D For 33889B	V_{DIFF2}	-3.5 -3.2	-3.0 -2.6	-2.5 -2.1	V
CANH Recessive Output Voltage $\text{TX} = 5.0 \text{ V}; R_{(RTH)} < 4.0 \text{ k}$	V_{CANH}			0.2	V
CANL Recessive Output Voltage $\text{TX} = 5.0 \text{ V}; R_{(RTL)} < 4.0 \text{ k}$	V_{CANL}	$V_{2-INT} - 0.2$			V

Table 4. Static Electrical Characteristics (continued).

Characteristics noted under conditions - V_{SUP} From 5.5 V to 18 V and T_J from -40°C to 125°C , unless otherwise noted. Typical values noted reflect the approximate parameter means at $T_A = 25^{\circ}\text{C}$ under nominal conditions unless otherwise noted.

Description	Symbol	Min	Typ	Max	Unit
CANH Output Voltage, Dominant TX = 0.0 V; $I_{CANH} = -40$ mA; Normal Operating Mode ⁽¹⁹⁾	V_{CANH}	$V_2 - 1.4$			V
CANL Output Voltage, Dominant TX = 0.0 V; $I_{CANL} = 40$ mA; Normal Operating Mode ⁽¹⁹⁾	V_{CANL}			1.4	V
CANH Output Current ($V_{CANH} = 0$; TX = 0.0) For 33889D For 33889B	I_{CANH}	50 50	100 75	130 110	mA
CANL Output Current ($V_{CANL} = 14$ V; TX = 0.0) For 33889D For 33889B	I_{CANL}	50 50	140 90	170 135	mA
Detection Threshold For Short-circuit To Battery Voltage (Normal Mode)	V_{CANH}, V_{CANL}	7.3	7.9	8.9	V
Detection Threshold For Short-circuit To Battery Voltage (Term VBAT Mode), MC33889B	V_{canH}	$V_{sup}/2+3$		$V_{sup}/2+5$	V
Detection Threshold For Short-circuit To Battery Voltage (Term VBAT Mode), MC33889D	V_{canH}	$V_{sup}/2+3$		$V_{sup}/2+4.55$	V
CANH Output Current (Term V_{BAT} Mode; $V_{CANH} = 12$ V, Failure3)	I_{CANH}		5.0	10	μA
CANL Output Current (Term V_{BAT} Mode; $V_{CANL} = 0.0$ V; $V_{BAT} = 12$ V, Failure 4)	I_{CANL}		0.0	2.0	μA
CANL Wake-Up Voltage Threshold	$V_{WAKE,L}$	2.5	3.0	3.9	V
CANH Wake-Up Voltage Threshold	$V_{WAKE,H}$	1.2	2.0	2.7	V
Wake-Up Threshold Difference (Hysteresis)	$V_{WAKE,L} - V_{WAKE,H}$	0.2			V
CANH Single Ended Receiver Threshold (Failures 4, 6, 7)	$V_{SE,CANH}$	1.5	1.85	2.15	V
CANL Single Ended Receiver Threshold (Failures 3, 8)	$V_{SE,CANL}$	2.8	3.05	3.4	V
CANL Pull Up Current (Normal Mode)	$I_{CANL,PU}$	45	75	90	μA
CANH Pull Down Current (Normal Mode)	$I_{CANH,PD}$	45	75	90	μA
Receiver Differential Input Impedance CANH / CANL	R_{DIFF}	100		300	kohm
Differential Receiver Common Mode Voltage Range ⁽²⁰⁾	V_{COM}	-10		10	V
CANH To Ground Capacitance	C_{CANH}			50	pF
CANL To Ground Capacitance	C_{CANL}			50	pF
C_{CANL} to C_{CANH} Capacitor Difference	DC_{CAN}			10	pF
CAN Driver Thermal Shutdown	t_{CSD}	150	160		$^{\circ}\text{C}$

Notes

19. For MC33889B, after 128 pulses on TX and no bus failure.
20. Guaranteed by design

Table 4. Static Electrical Characteristics (continued).

Characteristics noted under conditions - V_{SUP} From 5.5 V to 18 V and T_J from -40°C to 125°C , unless otherwise noted. Typical values noted reflect the approximate parameter means at $T_A = 25^{\circ}\text{C}$ under nominal conditions unless otherwise noted.

Description	Symbol	Min	Typ	Max	Unit
BUS TERMINATION PINS (RTH, RTL)					
RTL to V2 Switch On Resistance ($I_{OUT} < -10$ mA; Normal Operating Mode)	R_{RTL}	10	30	90	ohms
RTL to BAT Switch Series Resistance (term V_{BAT} Mode)	R_{RTL}	8.0	12.5	20	kohm
RTH To Ground Switch On Resistance ($I_{OUT} < 10$ mA; Normal Operating Mode)	R_{RTH}	10	30	90	ohm

DYNAMIC ELECTRICAL CHARACTERISTICS

Table 5. Dynamic Electrical Characteristics

V_{SUP} From 5.5 V to 18 V, $V2INT$ from 4.75 to 5.25 V and T_J from -40°C to 150°C unless otherwise noted. Typical values noted reflect the approximate parameter means at $T_A = 25^\circ\text{C}$ under nominal conditions unless otherwise noted.

Conditions	Symbol	Min	Typ	Max	Unit
DIGITAL INTERFACE TIMING (SCLK, \overline{CS}, MOSI, MISO)					
SPI operation frequency	FREQ	-	-	4.0	MHz
SCLK Clock Period	t_{PCLK}	250	-	-	ns
SCLK Clock High Time	t_{WSCLKH}	125	-	-	ns
SCLK Clock Low Time	t_{WSCLKL}	125	-	-	ns
Falling Edge of \overline{CS} to Rising Edge of SCLK	t_{LEAD}	100	50	-	ns
Falling Edge of SCLK to Rising Edge of \overline{CS}	t_{LAG}	100	50	-	ns
MOSI to Falling Edge of SCLK	t_{SISU}	40	25	-	ns
Falling Edge of SCLK to MOSI	t_{SIH}	40	25	-	ns
MISO Rise Time (CL = 220 pF)	t_{RSO}	-	25	50	ns
MISO Fall Time (CL = 220 pF)	t_{fSO}	-	25	50	ns
Time from Falling or Rising Edges of \overline{CS} to: - MISO Low Impedance - MISO High Impedance	t_{SOEN} t_{SODIS}	-	-	50 50	ns
Time from Rising Edge of SCLK to MISO Data Valid $0.2 V_1 \leq SO \leq 0.8 V_1, C_L = 200 \text{ pF}$	t_{VALID}	-	-	50	ns
Delay between \overline{CS} low to high transition (at end of SPI stop command) and Stop or sleep mode activation ⁽²¹⁾ detected by V2 off	$T_{\overline{CS}\text{-STOP}}$	18	-	34	μs
Interrupt low level duration SBC in stop mode	T_{INT}	7.0	10	13	μs
Internal oscillator frequency All modes except Sleep and Stop ⁽²¹⁾	O_{SC-F1}	-	100	-	kHz

Notes

21. Guaranteed by design

Table 5. Dynamic Electrical Characteristics (continued)

V_{SUP} From 5.5 V to 18 V, $V2INT$ from 4.75 to 5.25 V and T_J from -40°C to 150°C unless otherwise noted. Typical values noted reflect the approximate parameter means at $T_A = 25^{\circ}\text{C}$ under nominal conditions unless otherwise noted.

Conditions	Symbol	Min	Typ	Max	Unit
Internal low power oscillator frequency Sleep and Stop modes (22)	O_{SC-F2}	-	100	-	kHz
Watchdog period 1 Normal and standby modes	W_{D1}	8.58	9.75	10.92	ms
Watchdog period 2 Normal and standby modes	W_{D2}	39.6	45	50.4	ms
Watchdog period 3 Normal and standby modes	W_{D3}	88	100	112	ms
Watchdog period 4 Normal and standby modes	W_{D4}	308	350	392	ms
Watchdog period accuracy Normal and standby modes	$F1_{ACC}$	-12	-	12	%
Normal request mode timeout Normal request mode	NR_{TOUT}	308	350	392	ms
Watchdog period 1 - stop Stop mode	$WD1_{STOP}$	6.82	9.75	12.7	ms
Watchdog period 2- stop Stop mode	$WD2_{STOP}$	31.5	45	58.5	ms
Watchdog period 3 - stop Stop mode	$WD3_{STOP}$	70	100	130	ms
Watchdog period 4 - stop Stop mode	$WD4_{STOP}$	245	350	455	ms
Stop mode watchdog period accuracy Stop mode	$F2_{ACC}$	-30	-	30	%
Cyclic sense/FWU timing 1 Sleep and stop modes	$CSFWU1$	3.22	4.6	5.98	ms
Cyclic sense/FWU timing 2 Sleep and stop modes	$CSFWU2$	6.47	9.25	12	ms

Notes

22. Guaranteed by design

Table 5. Dynamic Electrical Characteristics (continued)

V_{SUP} From 5.5 V to 18 V, $V2INT$ from 4.75 to 5.25 V and T_J from -40°C to 150°C unless otherwise noted. Typical values noted reflect the approximate parameter means at $T_A = 25^{\circ}\text{C}$ under nominal conditions unless otherwise noted.

Conditions	Symbol	Min	Typ	Max	Unit
Cyclic sense/FWU timing 3 Sleep and stop modes	CSFWU3	12.9	18.5	24	ms
Cyclic sense/FWU timing 4 Sleep and stop modes	CSFWU4	25.9	37	48.1	ms
Cyclic sense/FWU timing 5 Sleep and stop modes	CSFWU5	51.8	74	96.2	ms
Cyclic sense/FWU timing 6 Sleep and stop modes	CSFWU6	66.8	95.5	124	ms
Cyclic sense/FWU timing 7 Sleep and stop modes	CSFWU7	134	191	248	ms
Cyclic sense/FWU timing 8 Sleep and stop modes	CSFWU8	271	388	504	ms
Cyclic sense On time in sleep and stop modes	t_{ON}	200	300	400	μs
Cyclic sense/FWU timing accuracy in sleep and stop mode	t_{ACC}	-30	-	+30	%
Delay between SPI command and HS1 turn on ⁽²³⁾ Normal or standby mode, $V_{SUP} > 9.0\text{ V}$	t_{S-HSON}	-	-	22	μs
Delay between SPI command and HS1 turn off ⁽²³⁾ Normal or standby mode, $V_{SUP} > 9.0\text{ V}$	$t_{S-HSOFF}$	-	-	22	μs
Delay between SPI and V2 turn on ⁽²³⁾ Standby mode	t_{S-V2ON}	9.0	-	25	μs
Delay between SPI and V2 turn off ⁽²³⁾ Normal modes	$t_{S-V2OFF}$	9.0	-	25	μs
Delay between Normal Request and Normal mode, after W/D trigger command Normal request mode	t_{S-NR2N}	15	35	70	μs

Notes

23. State Machine Timing - Delay starts at rising edge of \overline{CS} (end of SPI command) and start of Turn on or Turn off of HS1 or V2.

Table 5. Dynamic Electrical Characteristics (continued)

V_{SUP} From 5.5 V to 18 V, V_{2INT} from 4.75 to 5.25 V and T_J from -40°C to 150°C unless otherwise noted. Typical values noted reflect the approximate parameter means at $T_A = 25^{\circ}\text{C}$ under nominal conditions unless otherwise noted.

Conditions	Symbol	Min	Typ	Max	Unit
Delay between SPI and "CAN normal mode" SBC Normal mode ⁽²⁴⁾	t_{S-CANN}	-	-	10	μs
Delay between SPI and "CAN sleep mode" SBC Normal mode ⁽²⁴⁾	t_{S-CANS}	-	-	10	μs
Delay between $\overline{\text{CS}}$ wake-up ($\overline{\text{CS}}$ low to high) and SBC normal request mode (V_{DD1} on & reset high) SBC in stop mode	$t_{W-\overline{\text{CS}}}$	15	40	90	μs
Delay between $\overline{\text{CS}}$ wake-up ($\overline{\text{CS}}$ low to high) and first accepted SPI command SBC in stop mode	t_{W-SPI}	90	-	-	μs
Delay between INT pulse and 1st SPI command accepted In stop mode after wake-up	$t_{S-1STSPI}$	20	-	-	μs
Delay between two SPI messages addressing the same register For 33889D only	t_{2SPI}	25	-	-	μs

INPUT PINS (L0 AND L1)

Wake-up Filter Time (enable/disable option on L0 input) (If filter enabled)	t_{WUF}	8.0	20	38	μs
--	-----------	-----	----	----	---------------

PIN AC CHARACTERISTICS (CANH, CANL, RX, TX)

CANL and CANH Slew Rates (25% to 75% CAN signal). ⁽²⁵⁾ Recessive to Dominant state Dominant to Recessive state	t_{SLDR}	2.0 2.0		8.0 9.0	$\text{V}/\mu\text{s}$
Propagation Delay TX to RX Low. $-40^{\circ}\text{C} < T \leq 25^{\circ}\text{C}$. ⁽²⁶⁾ TX to RX Low. $25^{\circ}\text{C} < T < 125^{\circ}\text{C}$. ⁽²⁶⁾	t_{ONRX}		1.2 1.1	1.6 1.8	μs
Propagation Delay TX to RX High. ⁽²⁶⁾	t_{OFFRX}		1.8	2.2	μs

Notes

24. Guaranteed by design
25. Dominant to recessive slew rate is dependant upon the bus load characteristics.
26. AC Characteristics measured according to schematic [Figure 4](#)

Table 5. Dynamic Electrical Characteristics (continued)

V_{SUP} From 5.5 V to 18 V, V_{2INT} from 4.75 to 5.25 V and T_J from -40°C to 150°C unless otherwise noted. Typical values noted reflect the approximate parameter means at T_A = 25°C under nominal conditions unless otherwise noted.

Conditions	Symbol	Min	Typ	Max	Unit
Loop time Tx to Rx, no bus failure, MC33889D only ((27), Figure 5) (ISO ICT test series 10) Tx high to low transition (dominant edge) Tx low to high transition (recessive edge)	t _{LOOPRD}		1.15 1.45	1.5 1.5	μs
Loop time Tx to Rx, with bus failure, MC33889D only ((27), Figure 6) (ISO ICT test series 10) Tx high to low transition (dominant edge) Tx low to high transition (recessive edge)	t _{LOOPRD-F}		- -	1.9 1.9	μs
Loop time Tx to Rx, with bus failure and +-1.5V gnd shift, 5 nodes network, MC33889D,((28), Figure 7, ISO ICT tests series 11)	t _{LOOPRD/DR-F+GS}			3.6	μs
Min. Dominant Time For Wake-up On CANL or CANH (Term V _{bat} ; V _{SUP} = 12V) Guaranteed by design. MC33889B MC33889D	t _{WAKE}	8.0	30 16	30	μs
Failure 3 Detection Time (Normal Mode)	t _{DF3}	10	30	80	μs
Failure 3 Recovery Time (Normal Mode)	t _{DR3}		160		μs
Failure 6 Detection Time (Normal Mode)	t _{DF6}	50	200	500	μs
Failure 6 Recovery Time (Normal Mode)	t _{DR6}	150	200	1000	μs
Failure 4, 7 Detection Time (Normal Mode)	t _{DF47}	0.75	1.5	4.0	ms
Failure 4, 7 Recovery Time (Normal Mode)	t _{DR47}	10	30	60	μs
Failure 3a, 8 Detection Time (Normal Mode)	t _{DF8}	0.75	1.7	4.0	ms
Failure 3a, 8 Recovery Time (Normal Mode)	t _{DR8}	0.75	1.5	4.0	ms
Failure 4, 7 Detection Time, (Term V _{BAT} ; V _{SUP} = 12 V)	t _{DR47}	0.8	1.2	8.0	ms
Failure 4, 7 Recovery Time (Term V _{BAT} ; V _{SUP} = 12 V)	t _{DR47}		1.92		ms
Failure 3 Detection Time (Term V _{BAT} ; V _{SUP} = 12 V)	t _{DR3}		3.84		ms
Failure 3 Recovery Time (Term V _{BAT} ; V _{SUP} = 12 V)	t _{DR3}		1.92		ms
Failure 3a, 8Detection Time (Term V _{BAT} ; V _{SUP} = 12 V)	t _{DR8}		2.3		ms
Failure 3a, 8 Recovery Time (Term V _{BAT} ; V _{SUP} = 12 V)	t _{DR8}		1.2		ms

Notes

27. AC characteristic according to ISO11898-3, tested per figure 5 and 6. Guaranteed by design, room temperature only.
28. AC characteristic according to ISO11898-3, tested per figure 7. Max reported is the typical measurement under the worst condition (gnd shift, dominant/recessive edge, at source or destination node. ref to ISO test specification). Guaranteed by design, room temperature only.

Table 5. Dynamic Electrical Characteristics (continued)

V_{SUP} From 5.5 V to 18 V, V_{2INT} from 4.75 to 5.25 V and T_J from -40°C to 150°C unless otherwise noted. Typical values noted reflect the approximate parameter means at $T_A = 25^{\circ}\text{C}$ under nominal conditions unless otherwise noted.

Conditions	Symbol	Min	Typ	Max	Unit
Edge Count Difference Between CANH and CANL for Failures 1, 2, 5 Detection (Failure bit set, Normal Mode)	E_{CDF}		3		
Edge Count Difference Between CANH And CANL For Failures 1, 2, 5 Recovery (Normal Mode)	E_{CDR}		3		
TX Permanent Dominant Timer Disable Time (Normal Mode And Failure Mode)	$t_{TX,D}$	0.75		4.0	ms
TX Permanent Dominant Timer Enable Time (Normal Mode And Failure Mode)	$t_{TX,E}$	10		60	μs

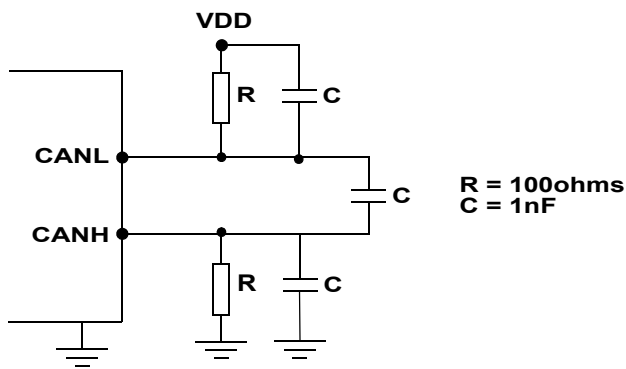

Figure 4. Test Circuit for AC Characteristics

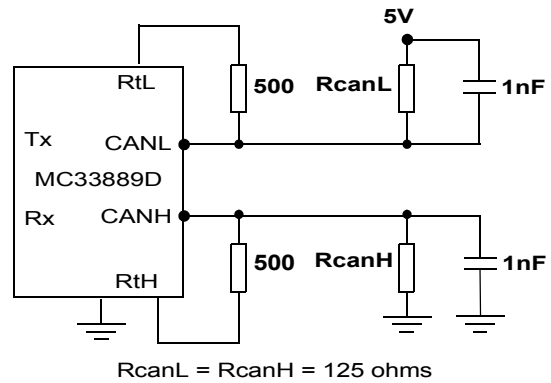
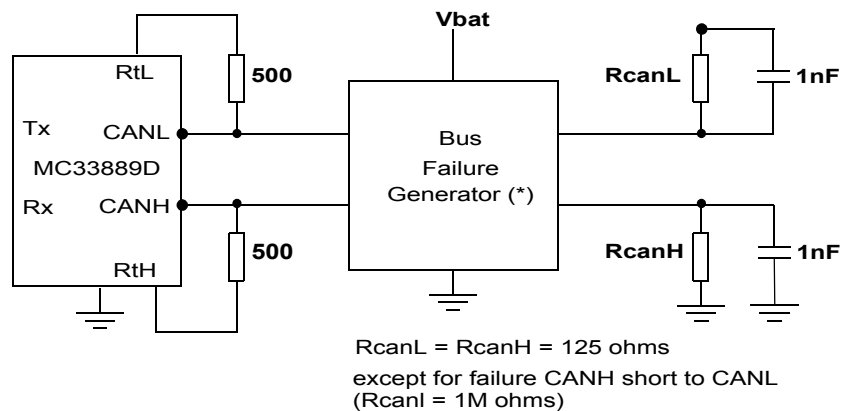

Figure 5. ISO loop time without bus failure



$R_{canL} = R_{canH} = 125$ ohms
 except for failure CANH short to CANL
 ($R_{canL} = 1\text{M}$ ohms)

(*) List of failure
 CANL short to gnd, Vdd, Vbat
 CANH short to gnd, Vdd, Vbat
 CANL short to CANH
 CANL and CANH open

Figure 6. ISO Loop Time with Bus Failure

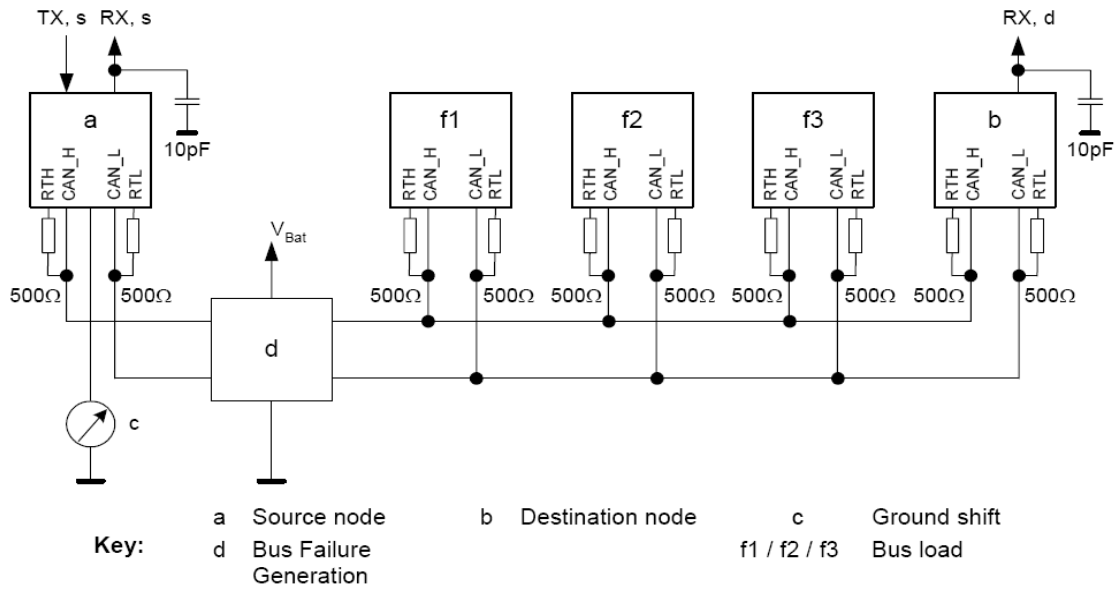

Figure 7. Test Set Up for Propagation Delay with GND Shift in a 5 Node Configuration

TIMING DIAGRAMS

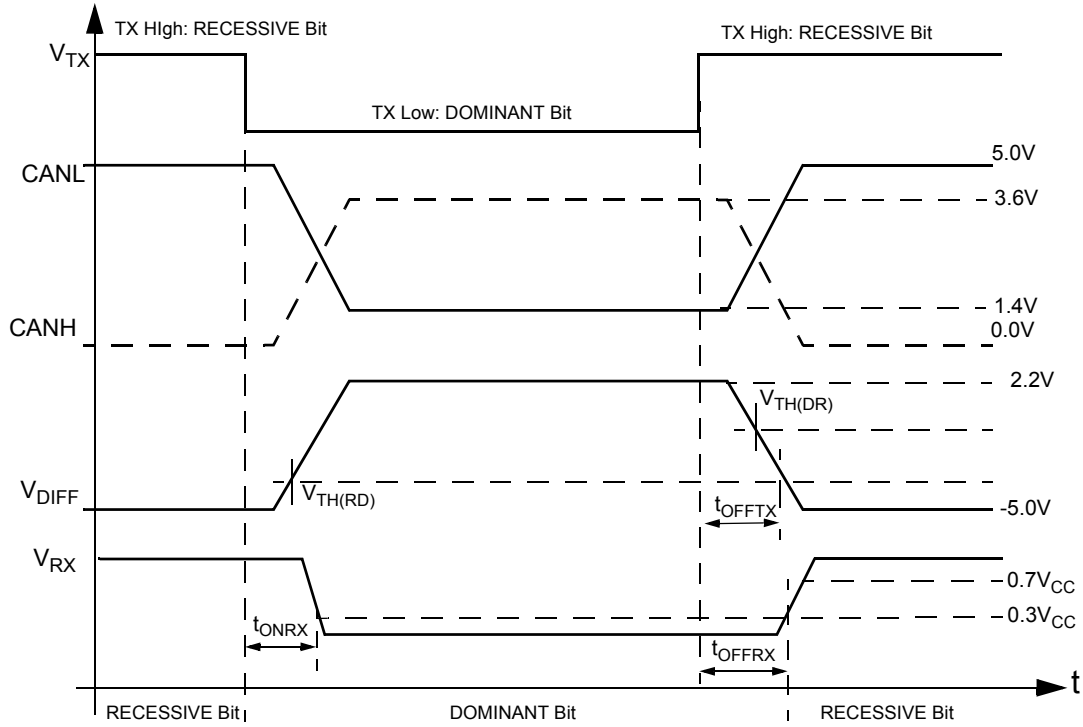

Figure 8. Device Signal Waveforms

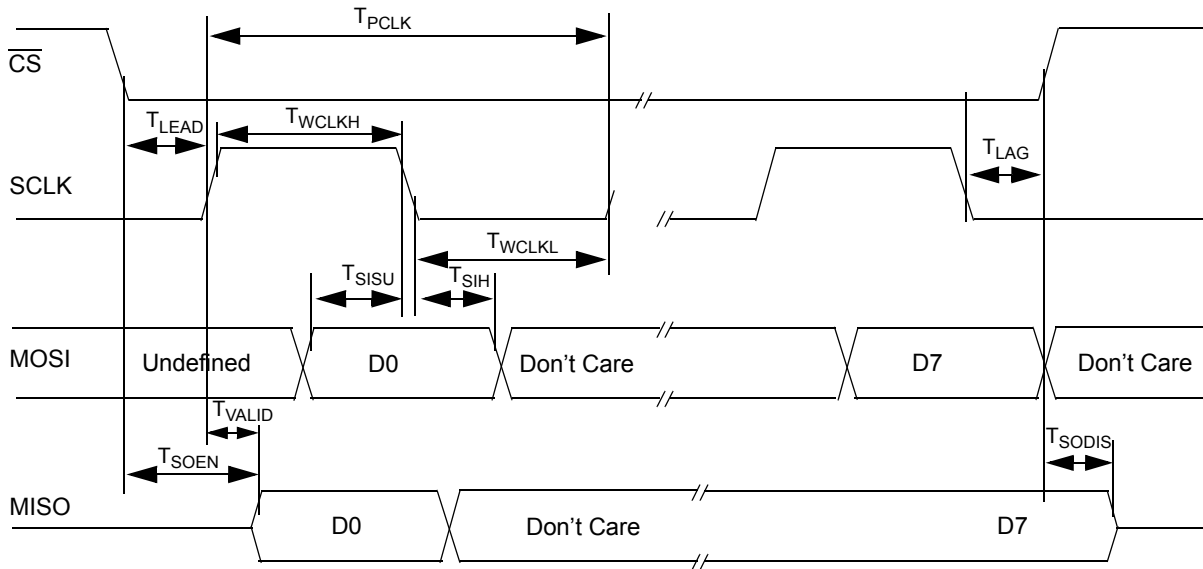

Figure 9. Timing Characteristic

FUNCTIONAL DESCRIPTION

INTRODUCTION

The MC33889 is an integrated circuit dedicated to automotive applications. It includes the following functions:

- One full protected voltage regulator with 200 mA total output current capability.
- Driver for external path transistor for V2 regulator function.

- Reset, programmable watchdog function
- Four operational modes
- Wake-up capabilities: Forced wake-up, cyclic sense and wake-up inputs, CAN and the SPI
- Can low speed fault tolerant physical interface.

FUNCTIONAL PIN DESCRIPTION

RECEIVE AND TRANSMIT DATA (RX AND TX)

The RX and TX pins (receive data and transmit data pins, respectively) are connected to a microcontroller's CAN protocol handler. TX is an input and controls the CANH and CANL line state (dominant when TX is LOW, recessive when TX is HIGH). RX is an output and reports the bus state (RX LOW when CAN bus is dominant, HIGH when CAN bus is recessive).

VOLTAGE REGULATOR ONE (VDD1)

The VDD1 pin is the output pin of the 5.0 V internal regulator. It can deliver up to 200 mA. This output is protected against overcurrent and overtemperature. It includes an overtemperature pre-warning flag, which is set when the internal regulator temperature exceeds 130°C typical. When the temperature exceeds the overtemperature shutdown (170°C typical), the regulator is turned off. VDD1 includes an undervoltage reset circuitry, which sets the RST pin LOW when VDD is below the undervoltage reset threshold.

RESET ($\overline{\text{RST}}$)

The Reset pin $\overline{\text{RST}}$ is an output that is set LOW when the device is in reset mode. The $\overline{\text{RST}}$ pin is set HIGH when the device is not in reset mode. $\overline{\text{RST}}$ includes an internal pullup current source. When $\overline{\text{RST}}$ is LOW, the sink current capability is limited, allowing $\overline{\text{RST}}$ to be shorted to 5.0 V for software debug or software download purposes.

INTERRUPT ($\overline{\text{INT}}$)

The Interrupt pin $\overline{\text{INT}}$ is an output that is set LOW when an interrupt occurs. $\overline{\text{INT}}$ is enabled using the Interrupt Register (INTR). When an interrupt occurs, $\overline{\text{INT}}$ stays LOW until the interrupt source is cleared. $\overline{\text{INT}}$ output also reports a wake-up event by a 10 sec. typical pulse when the device is in Stop mode.

GROUND (GND)

This pin is the ground of the integrated circuit.

V2CTRL (V2CTRL)

The V2CTRL pin is the output drive pin for the V2 regulator connected to the external series pass transistor.

VOLTAGE SUPPLY (VSUP)

The VSUP pin is the battery supply input of the device.

HIGH-SIDE OUTPUT 1 (HS1)

The HS pin is the internal high-side driver output. It is internally protected against overcurrent and overtemperature.

LEVEL 0-1 INPUTS (L0: L1)

The L0: L1 pins can be connected to contact switches or the output of other ICs for external inputs. The input states can be read by the SPI. These inputs can be used as wake-up events for the SBC when operating in the Sleep or Stop mode.

VOLTAGE REGULATOR TWO (V2)

The V2 pin is the input sense for the V2 regulator. It is connected to the external series pass transistor. V2 is also the 5.0 V supply of the internal CAN interface. It is possible to connect V2 to an external 5.0 V regulator or to the VDD output when no external series pass transistor is used. In this case, the V2CTRL pin must be left open.

RTH (RTH)

Pin for the connection of the bus termination resistor to CANH

RTL (RTL)

Pin for the connection of the bus termination resistor to CANL

CAN HIGH AND CAN LOW OUTPUTS (CANH AND CANL)

The CAN High and CAN Low pins are the interfaces to the CAN bus lines. They are controlled by TXD input level, and the state of CANH and CANL is reported through RXD output.

SYSTEM CLOCK (SCLK)

SCLK is the Serial Data Clock input pin of the serial peripheral interface.

MASTER IN/SLAVE OUT (MISO)

MISO is the Master In Slave Out pin of the serial peripheral interface. Data is sent from the SBC to the microcontroller through the MISO pin.

MASTER OUT/SLAVE IN (MOSI)

MOSI is the Master Out Slave In pin of the serial peripheral interface. Control data from a microcontroller is received through this pin.

CHIP SELECT (\overline{CS})

\overline{CS} is the Chip Select pin of the serial peripheral interface. When this pin is LOW, the SPI port of the device is selected.

WATCH DOG (\overline{WDOG})

The Watchdog output pin is asserted LOW to flag that the software watchdog has not been properly triggered.

FUNCTIONAL INTERNAL BLOCK DESCRIPTION**DEVICE SUPPLY**

The device is supplied from the battery line through the VSUP pin. An external diode is required to protect against negative transients and reverse battery. It can operate from 4.5 V and under the jump start condition at 27 V DC. This pin sustains standard automotive voltage conditions such as load dump at 40 V. When V_{SUP} falls below 3.0 V typical, the MC33889 detects it and stores the information in the SPI register, in a bit called "BATFAIL". This detection is available in all operation modes.

VDD1 VOLTAGE REGULATOR

VDD1 Regulator is a 5.0 V output voltage with total current capability of 200 mA. It includes a voltage monitoring circuitry associated with a reset function. The VDD1 regulator is fully protected against overcurrent, short-circuit and has overtemperature detection warning flags and shutdown with hysteresis.

V2 REGULATOR

V2 Regulator circuitry is designed to drive an external path transistor in order to increase output current flexibility. Two pins are used: V2 and V2CTRL. Output voltage is 5.0 V and is realized by a tracking function of the VDD1 regulator. A recommended ballast transistor is the MJD32C. Other transistors might be used, however depending upon the PNP gain, an external resistor capacitor network might be connected between the emitter and base of the PNP. The use of external ballast is optional (refer to simplified typical application). The state of V2 is reported into the IOR register (if V2 is below 4.5 V typical, or in cases of overload or short-circuit).

HS1 VBAT SWITCH OUTPUT

HS1 output is a 2.0 ohm typical switch from the VSUP pin. It allows the supply of external switches and their associated pullup or pull-down circuitry, for example, in conjunction with the wake-up input pins. Output current is limited to 200 mA and HS1 is protected against short-circuit and has an over temperature shutdown (reported into the IOR register). The HS1 output is controlled from the internal register and the SPI. It can be activated at regular intervals in sleep mode thanks to an internal timer. It can also be permanently turned on in normal or stand-by modes to drive external loads, such as relays or supply peripheral components. In case of inductive load drive, external clamp circuitry must be added.

SPI

The complete device control as well as the status report is done through an 8 bit SPI interface. Refer to the SPI paragraph.

CAN

The device incorporates a low speed fault tolerant CAN physical interface. The speed rate is up to 125 kBauds.

The state of the CAN interface is programmable through the SPI. Reference the [CAN transceiver description on page 30](#).

PACKAGE AND THERMAL CONSIDERATION

The device is proposed in a standard surface mount SO28 package. In order to improve the thermal performances of the SO28 package, 8 pins are internally connected to the lead frame and are used for heat transfer to the printed circuit board.

FUNCTIONAL DEVICE OPERATION

OPERATIONAL MODES

INTRODUCTION

The device has four modes of operation, normal, stand-by, sleep and stop modes. All modes are controlled by the SPI. An additional temporary mode called “normal request mode” is automatically accessed by the device (refer to state machine) after wake-up events. Special mode and configurations are possible for software application debug and flash memory programming.

NORMAL MODE

In this mode both regulators are ON, and this corresponds to the normal application operation. All functions are available in this mode (watchdog, wake-up input reading through the SPI, HS1 activation, and CAN communication). The software watchdog is running and must be periodically cleared through the SPI.

STANDBY MODE

Only the Regulator 1 is ON. Regulator 2 is turned OFF by disabling the V2CTRL pin. The CAN cell is not available, as powered from V2. Other functions are available: wake-up input reading through the SPI and HS1 activation. The watchdog is running.

SLEEP MODE

Regulators 1 and 2 are OFF. In this mode, the MCU is not powered. The device can be awakened internally by cyclic sense via the wake-up input pins and HS1 output, from the forced wake function, the CAN physical interface, and the SPI (\overline{CS} pin).

STOP MODE

Regulator 2 is turned OFF by disabling the V2CTRL pin. Regulator 1 is activated in a special low power mode which allows it to deliver 2.0 mA. The objective is to supply the MCU of the application while it is turned into a power saving condition (i.e stop or wait mode).

Stop mode is entered through the SPI. Stop mode is dedicated to powering the Microcontroller when it is in low power mode (stop, pseudo stop, wait etc.). In these modes, the MCU supply current is less than 1.0 mA. The MCU can restart its software application very quickly without the complete power up and reset sequence.

When the application is in stop mode (both MCU and SBC), the application can wake-up from the SBC side (ex cyclic sense, forced wake-up, CAN message, wake-up inputs) or the MCU side (key wake-up etc.).

When Stop mode is selected by the SPI, stop mode becomes active 20 μ s after end of the SPI message. The “go

to stop” instruction must be the last instruction executed by the MCU before going to low power mode.

In Stop mode, the Software watchdog can be “running” or “not running” depending on the selection by the SPI. Refer to the SPI description, RCR register bit WDSTOP. If the W/D is enabled, the SBC must wake-up before the W/D time has expired, otherwise a reset is generated. In stop mode, the SBC wake-up capability is identical as in sleep mode.

STOP MODE: WAKE-UP FROM SBC SIDE, INT PIN ACTIVATION

When an application is in stop mode, it can wake-up from the SBC side. When a wake-up is detected by the SBC (CAN, Wake-up input, forced wake-up, etc.), the SBC turns itself into Normal request mode and activates the VDD1 main regulator. When the main regulator is fully active, then the wake-up is signalled to the MCU through the \overline{INT} pin. The \overline{INT} pin is pulled low for 10 μ s and then returns high. Wake-up events can be read through the SPI registers.

STOP MODE: WAKE-UP FROM MCU SIDE

When the application is in stop mode, the wake-up event may come to the MCU. In this case, the MCU has to signal to the SBC that it has to go into Normal mode in order for the VDD1 regulator to be able to deliver full current capability. This is done by a low to high transition of the \overline{CS} pin. The \overline{CS} pin low to high activation has to be done as soon as possible after the MCU. The SBC generates a pulse at the \overline{INT} pin. Alternatively the L0 and L1 inputs can also be used as wake-up from the Stop mode.

STOP MODE CURRENT MONITORING

If the current in Stop mode exceeds the $I_{DD1S-WU}$ threshold, the SBC jumps into Normal request mode, activates the VDD1 main regulator, and generates an interrupt to the MCU. This interrupt is not maskable and a not bit are set into the \overline{INT} register.

SOFTWARE WATCHDOG IN STOP MODE

If the watchdog is enabled (register MCR, bit WDSTOP set), the MCU has to wake-up independently of the SBC before the end of the SBC watchdog time. In order to do this, the MCU has to signal the wake-up to the SBC through the SPI wake-up (\overline{CS} pin low to high transition to activated the SPI wake-up). Then the SBC wakes up and jumps into the normal request mode. The MCU has to configure the SBC to go to either into normal or standby mode. The MCU can then choose to go back into stop mode.

If no MCU wake-up occurs within the watchdog timing, the SBC will activate the reset pin and jump into the normal request mode. The MCU can then be initialized.

NORMAL REQUEST MODE

This is a temporary mode automatically accessed by the device after a wake-up event from sleep or stop mode, or after device power up. In this mode, the VDD1 regulator is ON, V2 is off, and the reset pin is high. As soon as the device enters the normal request mode, an internal 350 ms timer is started. During these 350 ms, the microcontroller of the application must address the SBC via the SPI and configure the watchdog register (TIM1 register). This is the condition for the SBC to leave the Normal request Mode and enter the Normal mode, and to set the watchdog timer according to the configuration done during the Normal Request mode.

The “BATFAIL flag” is a bit which is triggered when V_{SUP} falls below 3.0 V. This bit is set into the MCR register. It is reset by the MCR register read.

INTERNAL CLOCK

This device has an internal clock used to generate all timings (reset, watchdog, cyclic wake-up, filtering time etc....).

RESET PIN

A reset output is available in order to reset the microcontroller. Reset causes are:

- V_{DD1} falling out of range: if V_{DD1} falls below the reset threshold (parameter R_{ST-TH}), the reset pin is pulled low until V_{DD1} returns to the nominal voltage.
- Power on reset: at device power on or at device wake-up from sleep mode, the reset is maintained low until V_{DD1} is within its operation range.
- Watchdog timeout: if the watchdog is not cleared, the SBC will pull the reset pin low for the duration of the reset duration time (parameter: RESET-DUR).

For debug purposes at 25°C, the reset pin can be shorted to 5.0 V.

SOFTWARE WATCHDOG (SELECTABLE WINDOW OR TIMEOUT WATCHDOG)

The software watchdog is used in the SBC normal and stand-by modes for monitoring the MCU. The watchdog can be either a window or timeout. This is selectable by the SPI (register TIM, bit WDW). Default is the window watchdog. The period of the watchdog is selectable by the SPI from 5.0 to 350 ms (register TIM, bits WDT0 and WDT1). When the window watchdog is selected, the closed window is the first half of the selected period, and the open window is the second half of the period. The watchdog can only be cleared within the open window time. An attempt to clear the watchdog in the closed window will generate a reset. The Watchdog is cleared through the SPI by addressing the TIM register.

Refer to “table for reset pin operations” operation in mode 2.

WAKE-UP CAPABILITIES

Several wake-up capabilities are available for the device when it is in sleep or stop mode. When a wake-up has occurred, the wake-up event is stored into the WUR or CAN registers. The MCU can then access the wake-up source. The wake-up options are selectable through the SPI while the device is in normal or standby mode, and prior to entering low power mode (sleep or stop mode).

WAKE-UP FROM WAKE-UP INPUTS (L0, L1) WITHOUT CYCLIC SENSE

The wake-up lines are dedicated to sense external switch states, and when changes occur to wake-up the MCU (In sleep or stop modes). The wake-up pins are able to handle 40 V DC. The internal threshold is 3.0 V typical, and these inputs can be used as an input port expander. The wake-up inputs state can be read through the SPI (register WUR). L0 has a lower threshold than L1 in order to allow a connection and wake-up from a digital output such as a CAN physical interface.

CYCLIC SENSE WAKE-UP (CYCLIC SENSE TIMER AND WAKE-UP INPUTS L0, L1)

The SBC can wake-up from a state change of one of the wake-up input lines (L0, L1), while the external pullup or pulldown resistor of the switches associated to the wake-up input lines are biased with HS1 VSUP switch. The HS1 switch is activated in sleep or stop mode from an internal timer. Cyclic sense and forced wake-up are exclusive. If Cyclic sense is enabled, the forced wake-up can not be enabled.

INFO FOR CYCLIC SENSE + DUAL EDGE SELECTION

In case the Cyclic sense and Lx both level sensitive conditions are use together, the initial value for Lx inputs are sampled in two cases:

- 1) When the register LPC[D3 and D0] are set and
- 2) At cyclic sense event, that is when device is in sleep or stop mode and HS1 is active.

The consequence is that when the device wake up by Lx transition, the new value is sampled as default, then when the device is set back into low power again, it will automatically wake up.

The user should reset the LPC bits [D3 and D0] to 0 and set them again to the desired value prior to enter sleep or stop mode.

FORCED WAKE-UP

The SBC can wake-up automatically after a predetermined time spent in sleep or stop mode. Forced wake-up is enabled by setting bit FWU in the LPC register. Cyclic sense and forced wake-up are exclusive. If forced wake-up is enabled, the Cyclic sense can not be enabled.

CAN WAKE-UP

The device can wake-up from a CAN message. A CAN wake-up cannot be disabled.

SPI WAKE-UP

The device can wake-up by the \overline{CS} pin in sleep or stop mode. Wake-up is detected by the CS pin transition from a low to high level. In stop mode this correspond to the condition where the MCU and SBC are both in Stop mode, and when the application wake-up events come through the MCU.

SYSTEM POWER UP

At power up the device automatically wakes up.

DEVICE POWER UP, SBC WAKE UP

After device or system power up or a wake-up from sleep mode, the SBC enters into “reset mode” then into “normal request mode”.

BATTERY FALL EARLY WARNING

This function provides an interrupt when the VSUP voltage is below the 6.1 V typical. This interrupt is maskable. A hysteresis is included. Operation is only in Normal and Stand-by modes. VBAT low state reports in the IOR register.

RESET AND \overline{WDOG} OPERATION

The following figure shows the reset and watchdog output operations. Reset is active at device power up and wake-up. Reset is activated in case the VDD1 falls or the watchdog is not triggered. The \overline{WDOG} output is active low as soon as the reset goes low and stays low for as long as the watchdog is not properly re-activated by the SPI.

The \overline{WDOG} output pin is a push pull structure than can drive external components of the application, for instance to signal the MCU is in a wrong operation. Even if it is internally turned on (low-state), the reset pin can be forced to 5.0 V at 25°C only, thanks to its internally limited current drive capability. The \overline{WDOG} stays low until the Watchdog register is properly addressed through the SPI.

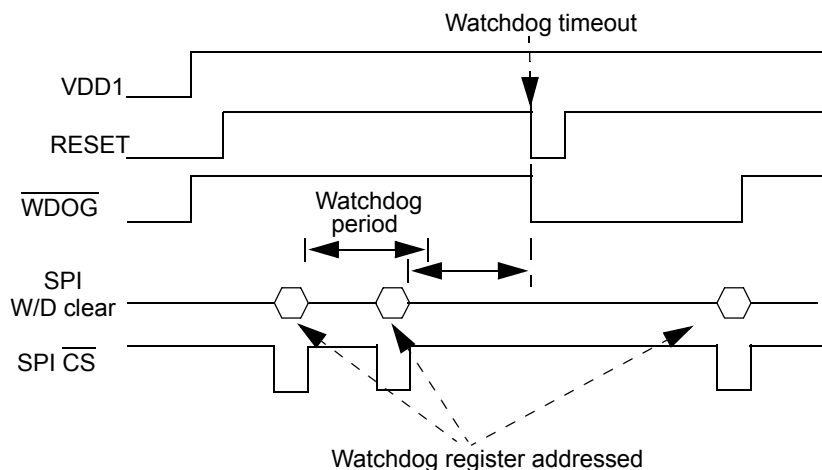

Figure 10. Reset and \overline{WDOG} Function Diagram

DEBUG MODE APPLICATION HARDWARE AND SOFTWARE DEBUG WITH THE SBC.

When the SBC is mounted on the same printed circuit board as the micro controller, it supplies both application software and the SBC with a dedicated routine that must be debugged. The following features allow the user to debug the software by disabling the SBC internal software watchdog timer.

DEVICE POWER UP, RESET PIN CONNECTED TO VDD1

At SBC power up, the VDD1 voltage is provided, but if no SPI communication occurs to configure the device, a reset occurs every 350 ms. In order to allow software debugging and avoid an MCU reset, the Reset pin can be connected directly to VDD1 by a jumper.

DEBUG MODES WITH SOFTWARE WATCHDOG DISABLED THROUGH SPI (NORMAL DEBUG, STANDBY DEBUG AND STOP DEBUG)

The software watchdog can be disabled through the SPI. In order to avoid unwanted watchdog disables, and to limit the risk of disabling the watchdog during an SBC normal operation, the watchdog disable has to be performed with the following sequence:

- Step 1) Power down the SBC
- Step 2) Power up the SBC (The BATFAIL bit is set, and the SBC enters normal request mode)
- Step 3) Write to the TIM1 register to allow the SBC to enter Normal mode
- Step 4) Write to the MCR register with data 0000 (this enables the debug mode). (Complete SPI byte: 000 1 0000)

Step 5) Write to the MCR register normal debug (0001 x101), stand-by debug (0001 x110), or Stop debug (0001 x111)

While in debug mode, the SBC can be used without having to clear the W/D on a regular basis to facilitate software and hardware debugging.

Step 6) To leave the debug mode, write 0000 to the MCR register.

To avoid entering the debug mode after a power up, first read the BATFAIL bit (MCR read) and write 0000 into the MCR.

[Figure 11](#) illustrates entering the debug mode.

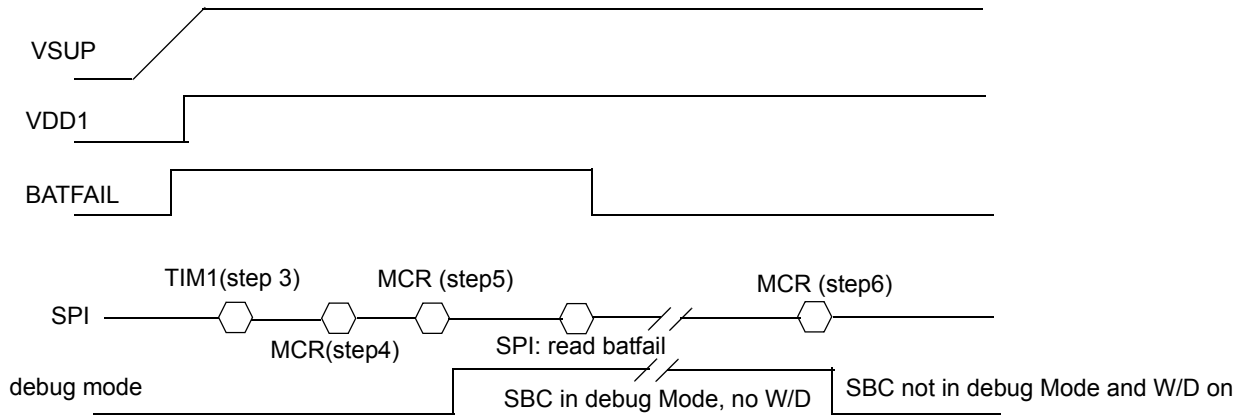

Figure 11. Debug Mode Enter

MCU FLASH PROGRAMMING CONFIGURATION

To facilitate the possibility of down loading software into the application memory (MCU EEPROM or Flash), the SBC allows the following capabilities: The VDD1 can be forced by an external power supply to 5.0 V and the reset and WDOG

output by external signal sources to zero or 5.0 V without damage. This supplies the complete application board with external power supply and applies the correct signal to the reset pin.

CAN TRANSCEIVER DESCRIPTION

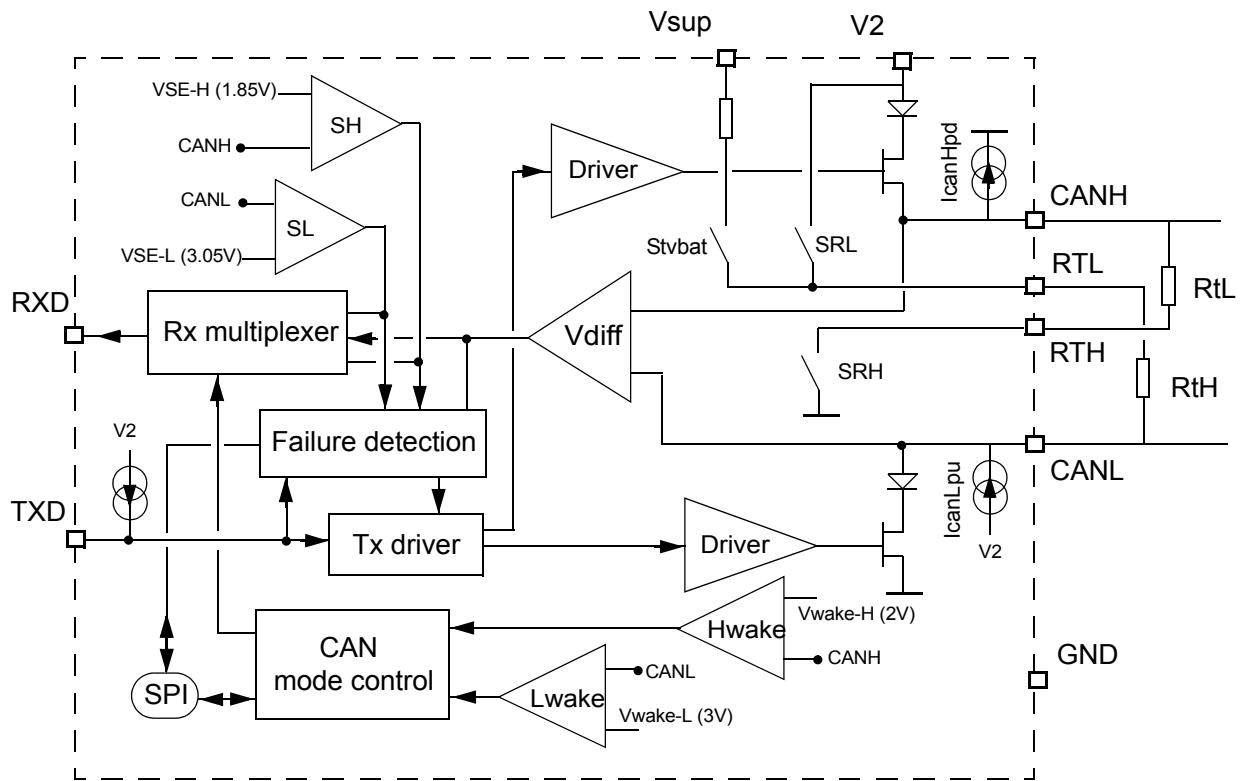

Figure 12. Simplified Block Diagram of the CAN Transceiver of the MC33889

General description

CAN driver:

The CANH driver is a "high side" switch to the V2 voltage (5V). The CANL driver is a "low side" switch to gnd. The turn on and turn off time is controlled in order to control the slew rate, and the CANH and CANL driver have a current limitation as well as an over temperature shutdown.

The CAN H or CANL driver can be disabled in case a failure is detected on the CAN bus (ex: CANH driver is disabled in case CANH is shorted to V_{DD}). The disabling of one of the drivers is controlled by the CAN logic and the communication continues via the other drivers. When the failure is removed the logic detects a failure recovery and automatically reenables the associated driver.

The CAN drivers are also disabled in case of a Tx failure detection.

Bus termination:

The bus is terminated by pull up and pull down resistors, which are connected to GND, VDD or VBAT through dedicated RTL and RTH pins and internal switches Srh, Srl,

Stvbat. Each node must have a resistor connected between CANH and RTH and between CANL and RTL. The resistor value should be between 500 and 16000 ohms.

Transmitter Function

CAN bus levels are called Dominant and Recessive, and correspond respectively to Low and High states of the TX input pin.

Dominant state:

The CANH and CANL drivers are on. The voltage at CANL is $<1.4V$, the voltage at CANH is $>3.6V$, and the differential voltage between CANH and CANL line is $>2.2V$ ($3.6V - 1.4V$).

Recessive state:

This is a weak state, where the CANH and CANL drivers are off. The CANL line is pulled up to 5V via the RTL pin and RTL resistor, and the CANH line is pull down via the RTH and RTH resistor. The resultant voltage at CANL is 5V and 0V at CANH. The differential voltage is $-5V$ ($0V - 5V$). The recessive state can be over written by any other node forcing a Dominant state.

Receiver Function

In normal operation (no bus failures), RX is the image of the differential bus voltage. The differential receiver inputs are connected to CANH and CANL.

The device incorporates single ended comparators connected to CANH and CANL in order to monitor the bus state as well as detect bus failures. Failures are reported via the SPI.

In normal operation when no failure is present, the differential comparator is active. Under a fault condition, one of the two CANH or CANL pins can become non-operational. The single ended comparator of either CANH or CANL is activated and continues to report a bus state to Rx pin. The device permanently monitors the bus failure and recovery, and as soon as fault disappears, it automatically switches back to differential operation.

CAN interface operation Mode

The CAN has 3 operation modes: TxRx (Transmit-Receive), Receive Only, and Term-VBAT (Terminated to VBAT). The mode is selected by the SPI. As soon as the MC33889 mode is sleep or stop (selected via MCR register), the CAN interface automatically enters Tem-Vbat mode.

Tx Rx mode:

In this mode, the CAN drivers and receivers are enabled, and the device is able to send and receive messages. Bus failures are detected and managed, this means that in case of a bus failure, one of the CAN drivers can be disabled, but communication continues via the remaining drivers.

Receive Only mode:

In this mode, the transmitter path is disabled, so the device does not drive the bus. It maintains CANL and CANH in the recessive state. The receiver function operates normally.

TermVbat mode:

In this mode, the transmitter and receiver functions are disabled. The CANL pin is connected to V_{SUP} through the

RTL resistor and internal pull up resistor of 12.5kOhms. In this mode, the device monitors the bus activity and if a wake up conditions is encountered on the CAN bus, it will wakes up the MC33889.

The device will enter into a normal request mode if low power mode was in sleep, or generates an INT. It enters into Normal request mode if low power mode was in stop mode. If the device was in normal or stand by mode, the Rx pin will report a wake up (feature not available on the MC33889B). See Rx pin behavior.

Bus Failure Detection**General description:**

The device permanently monitors the bus lines and detects faults in normal and receive only modes. When a fault is detected, the device automatically takes appropriate actions to minimize the system current consumption and to allow communication on the network. Depending on the type of fault, the mode of operation, and the fault detected, the device automatically switches off one or more of the following functions: CANL or CANH line driver, RTL or RTH termination resistors, or internal switches. These actions are detailed in the following table.

The device permanently monitors the faults and in case of fault recovery, it automatically switches back to normal operation and reconnects the open functions. Fault detection and recovery circuitry have internal filters and delays timing, detailed in the AC characteristics parameters.

The failure list identification and the consequence on the device operation are described in following table. The failure detection, and recovery principle, the transceiver state after a failure detected, timing for failure detection and recovery can be found in the ISO11898-3 standard.

The following table is a summary of the failure identifications and of the consequences on the CAN driver and receiver when the CAN is in Tx Rx mode.

Bus failure identification	Description	Consequence on CAN driver	Consequence on Rx pin
	no failure	default operation: CAN H and CANL driver active, RTH and RTL termination switched ON	default operation: Report differential receiver output
1	CANH open wire	default operation	default operation
5	CANH shorted to gnd	default operation	default operation
8, 3a	CANH shorted to Vdd (5V)	CANH driver turn OFF. RTH termination switched OFF	Rx report CANL single ended receiver
3	CANH shorted to Vbat	CANH driver turn OFF. RTH termination switched OFF	Rx report CANL single ended receiver
2	CANL open wire	default operation	default operation
4, 7	CANL shorted to gnd or CANL shorted to CANH	CANL driver is OFF. RTL termination switched OFF	Rx report CANH single ended receiver
9	CANL shorted to Vdd (5V)	CANL driver is ON. RTL termination active	default operation
6	CANL shorted to Vbat	CANL driver is OFF. RTL termination switched OFF	Rx report CANH single ended receiver

Open wire detection operation:

Description:

The CANH and CANL open wire failures are not described in the ISO document. Open wire is only diagnostic information, as no CAN driver or receiver state will change in case of an open wire condition.

In case one of the CAN wires are open, the communication will continue through the remaining wire. In this situation the

MC33889 will receive information on one wire only and the consequences are as follows:

when the bus is set in dominant:

- The differential receiver will toggle
- Only one of the single ended receivers CANH or of CANL will toggle

The following figure illustrates the CAN signal during normal communication and in the example of a CANH open wire. The single ended receiver is sampled at the differential receiver switching event, in a window of 1µs.

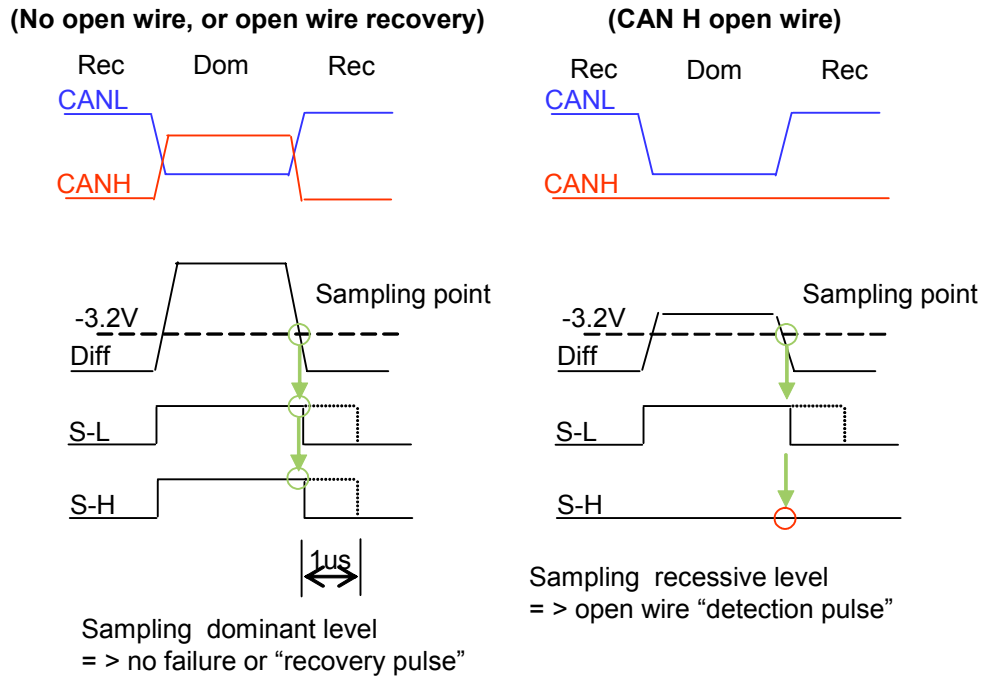

Figure 13. CAN Normal Signal Communication and CAN Open Wire

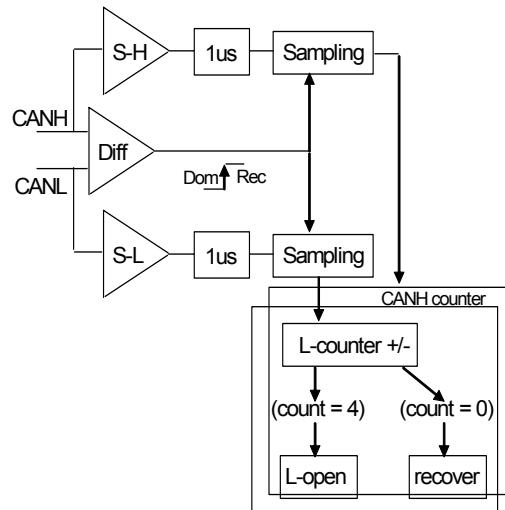

Figure 14. Open Wire Detection Principle

Open wire detection, MC33889B and D:

Failure detection:

The device will detect a difference in toggling counts between the differential receiver and one of the single ended receivers. Every time a difference in count is detected a counter is incremented. When the counter reaches 4, the device detects and reports an open wire condition. The open wire detection is performed only when the device receives a message and not when it send message.

Open wire recovery:

When the open wire failure has recovered, the difference in count is reduced and the device detects the open wire recovery.

MC33889B:

When detection is complete, the counter is no longer incremented. It can only be decremented by sampling of the dominant level on the S-H (S-L) (recovery pulse). When it reaches zero, the failure has recovered.

In application, with CAN communication, a recovery condition is detected after 4 acknowledge bits are sent by the MC33889B.

MC33889D:

When detection is complete, the counter is decremented by sampling the dominant pulse (recovery pulse) on S-H (S-L), and incremented (up to 4) by sampling the recessive pulse (detection pulses) on S-H (S-L). It is necessary to get 4 consecutive dominant samples (recovery pulse) to get to zero. When reaching zero, the failure is recovered.

In application with real CAN communication, a recovery condition will not be detected by a single acknowledge bit send by MC33889D, but requires a complete CAN message (at least 4 dominant bits) send in dual wire mode, without reception of any bit in single wire mode.

Tx permanent dominant detection:

In addition to the previous list, the MC33889 detects a permanent low state at the TX input which results in a

permanent dominant bus state. If TX is low for more than 0.75-4ms, the bus output driver is disabled. This avoids blocking communication between other nodes of the network. TXD is reported via the SPI (RCR register bit D1: TXFAILURE). Tx permanent dominant recovery is done with TX recessive for more than t_{yp} 32us.

Rx pin behavior while CAN interface is in TermVbat.

The MC33889D is able to signal bus activity on Rx while the CAN interface is in TermVbat and the SBC in normal or standby mode. When the bus is driven into a dominant state by another sending node, each dominant state is reported at Rx by a low level, after a delay of T_{WAKE} .

The bus state report is done through the CAN interface wake up comparator on CANL and CANH, and thus operates also in case of bus failure. This is illustrated in the following figure.

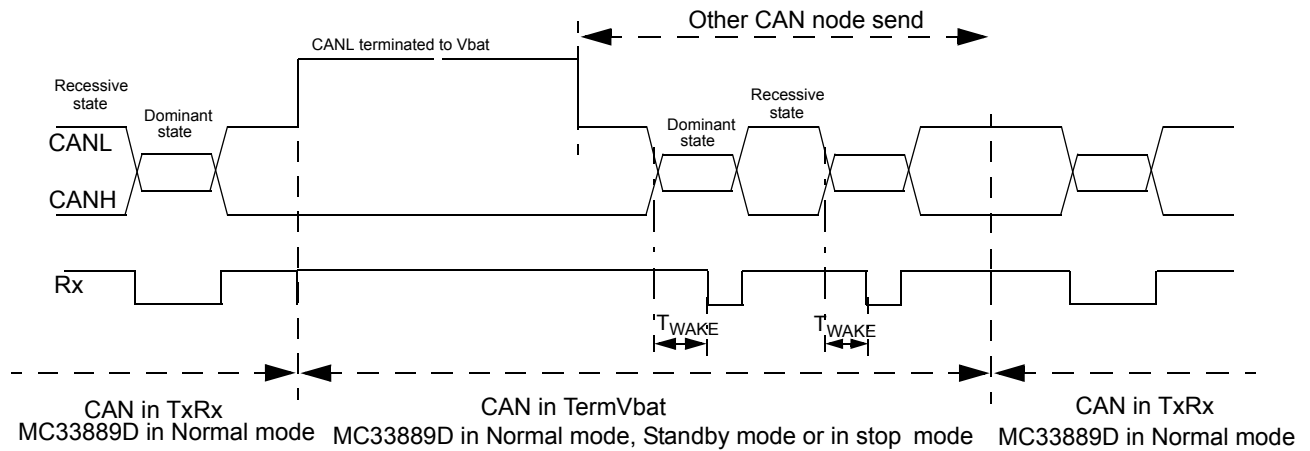

T_{WAKE} : duration of the CAN wake up filter, typ $16\mu s$. The MC33889D Rx dominant low level duration is the difference between the duration of the bus minus the T_{wake} , as illustrated below ($Trx_dom = Tbus_dom - T_{wake}$)

Example: A dominant duration at the bus level of 5 bits of 8us each results in a 40us bus dominant. This results in a 24us ($40\mu s - 16\mu s$) dominant level at Rx of MC33889D (while the CAN of the MC33889D is in TermVbat).

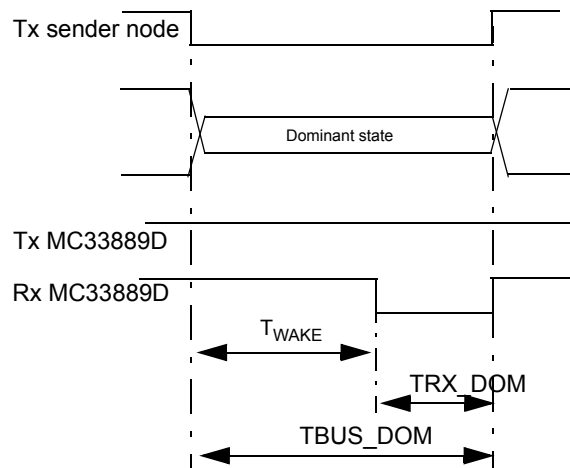

Figure 15. Bus State Report of the CAN Interface Wake-Up Comparator on CANL and CANH

The following table summarizes the device behavior when a CAN Wake Up event occurs.

Table 6. Summary of RX Pin Operations for Wake up Signaling

SBC mode	CAN state	MC33889B	MC33889D
Normal	TermVbat	no event on RX, no bit set	RX pulse (1), bit CANWU is not set
Standby	TermVbat	no event on RX, no bit set	RX pulse (1), bit CANWU is not set
Sleep	TermVbat	SBC mode transition to Normal request, bit CANWU set	SBC mode transition to Normal request, bit CANWU set
Stop	TermVbat	INT pulse, bit CANWU set	Int pulse, bit CANWU set

Notes

29. pulse duration is bus dominant duration minus Twake.

GND SHIFT DETECTION

GENERAL

When normally working in two-wire operating mode, the CAN transmission can afford some ground shift between different nodes without trouble. Should a bus failure occur, the transceiver switches to single-wire operation, therefore working with less noise margin. The affordable ground shift is decreased.

The SBC provides a ground shift detection for diagnosis purpose. The four ground shift levels are selectable and the detection is stored in the IOR register which is accessible via the SPI.

Table 7. 33889 Table of Operations

The table below describe the SBC operation modes.

MODE	VOLTAGE REGULATOR HS1 SWITCH	WAKE-UP CAPABILITIES (IF ENABLED)	RESET PIN	INT	SOFTWARE WATCHDOG	CAN CELL
Normal Request	VDD1: ON V2: OFF HS1: OFF		Low for 1ms, then high			term Vbat
Normal	VDD1: ON V2: ON HS1 controllable		Normally high. Active low if W/D or VDD1 under voltage occur	If enabled, signal failure (VDD pre warning temp, CAN, HS1)	Running	Term Vbat Tx/Rx Rec only
Standby	VDD1: ON V2: OFF HS1 controllable		Normally high. Active low if W/D or VDD1 under voltage occur	If enabled, signal failure (VDD temp, HS1)	Running	Term Vbat Tx/Rx Rec only
Stop	VDD1: ON (limited current capability) V2: OFF HS1: OFF or cyclic	CAN (always enable) SPI and L0,L1 Cyclic sense or Forced Wake-up	Normally high. Active low if W/D or VDD1 under voltage occur	Signal SBC wake-up (not maskable)	- Running if enabled - Not Running if disabled	Term Vbat.

DETECTION PRINCIPLE

The gnd shift to detect is selected via the SPI from 4 different values (-0.3 V, -0.7 V, -1.2 V, -1.7 V). At each TX falling edge (end of recessive state), the CANH voltage is sensed. If it is detected to be below the selected gnd shift threshold, the bit SHIFT is set at 1 in the IOR register. No filter is implemented. Required filtering for reliable detection should be done by software (e.g. several trials).

DEVICE STATE DESCRIPTION

Table 7. 33889 Table of Operations

The table below describe the SBC operation modes.

MODE	VOLTAGE REGULATOR HS1 SWITCH	WAKE-UP CAPABILITIES (IF ENABLED)	RESET PIN	INT	SOFTWARE WATCHDOG	CAN CELL
Sleep	VDD1: OFF V2: OFF HS1 OFF or cyclic	CAN (always enable) SPI and L0,L1 Cyclic sense Forced Wake-up	Low	Not active	No Running	Term Vbat.

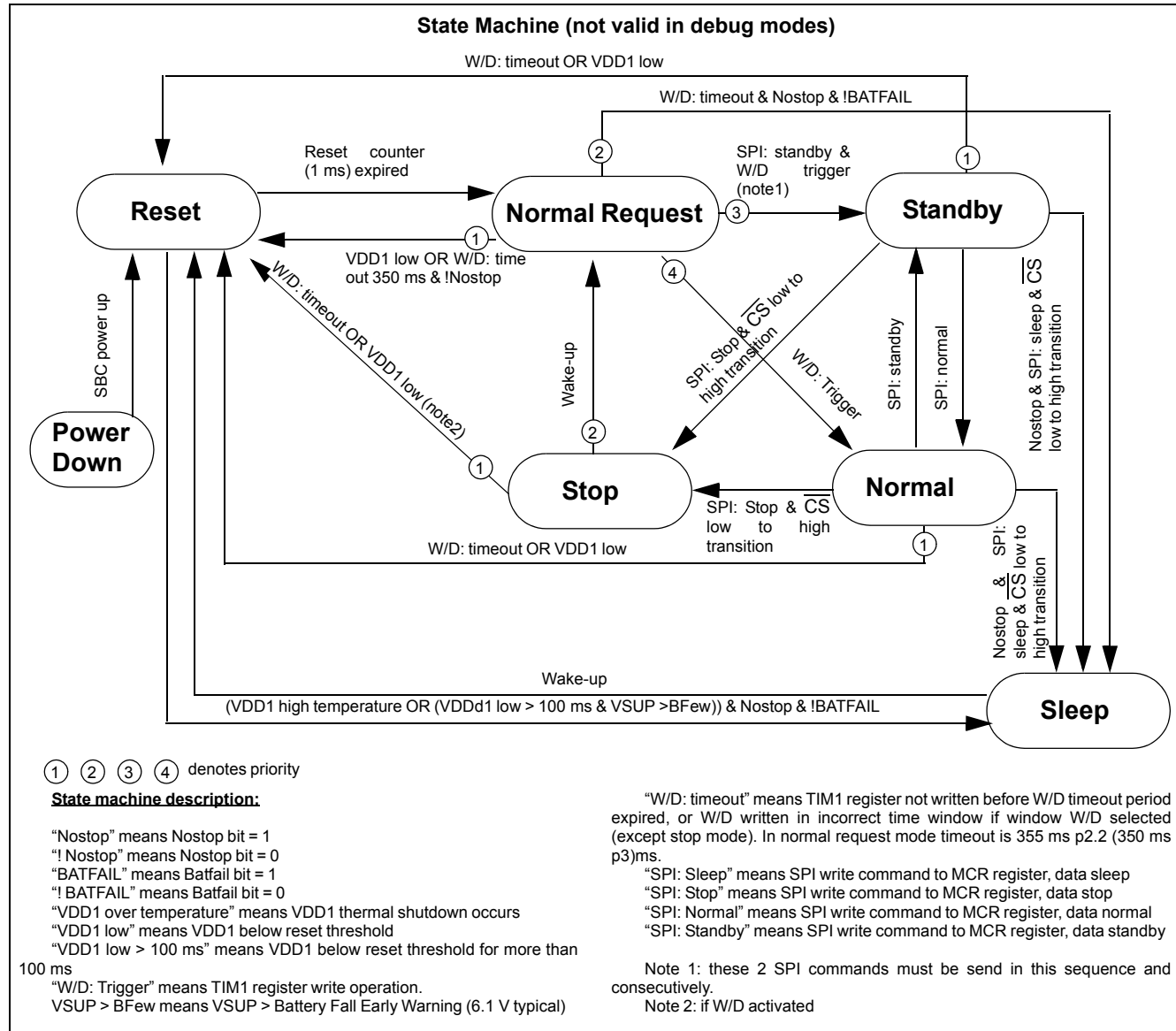

Figure 16. Simplified State Machine

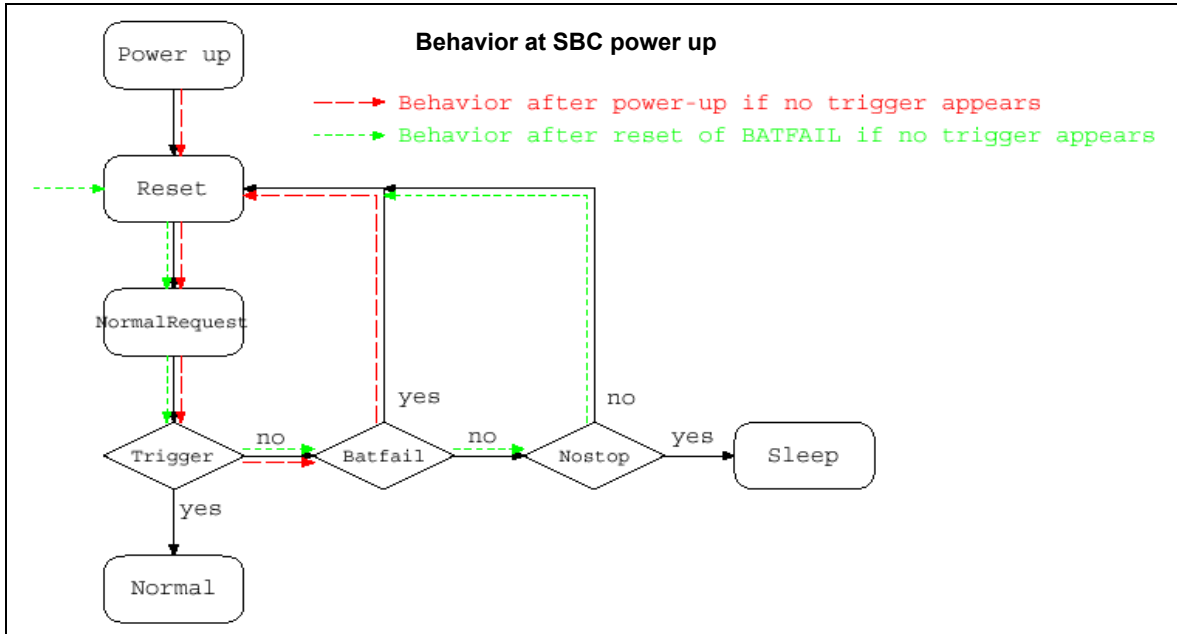

Figure 17. Behavior at SBC Power Up

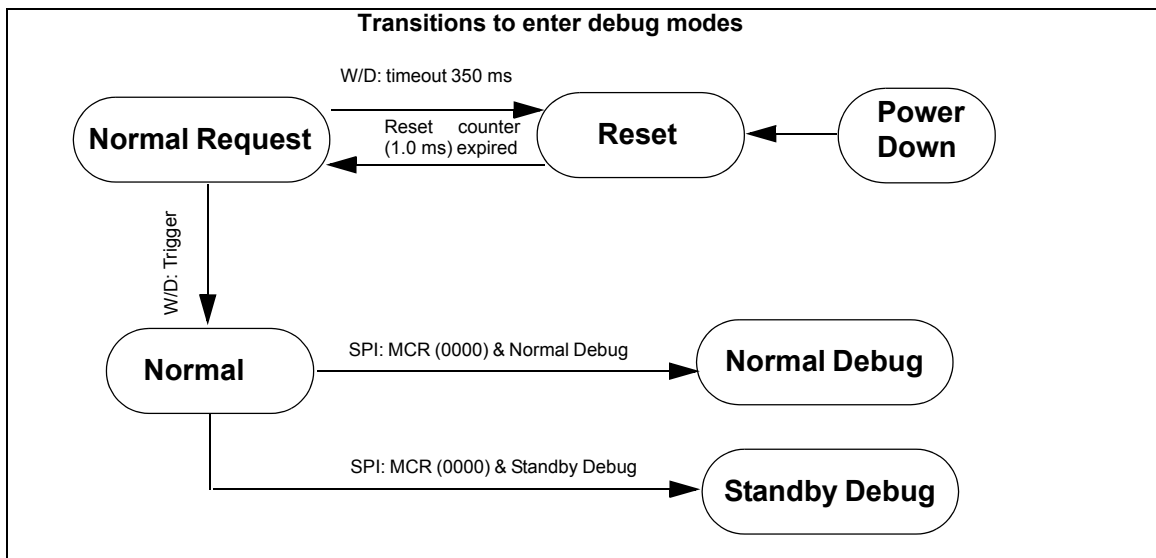

Figure 18. Transitions to Enter Debug Modes

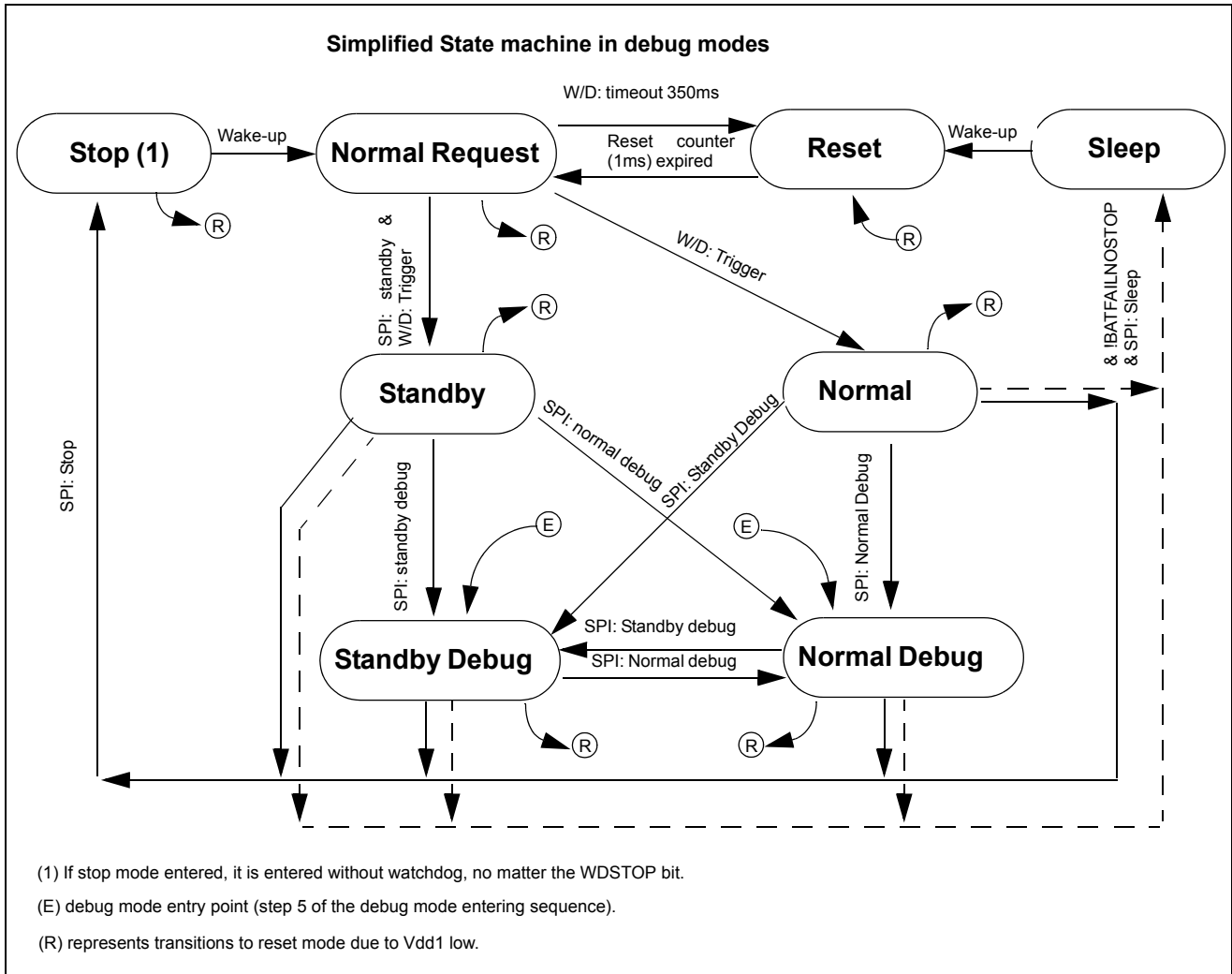

Figure 19. Simplified State Machine in Debug Mode

LOGIC COMMANDS AND REGISTERS

SPI INTERFACE

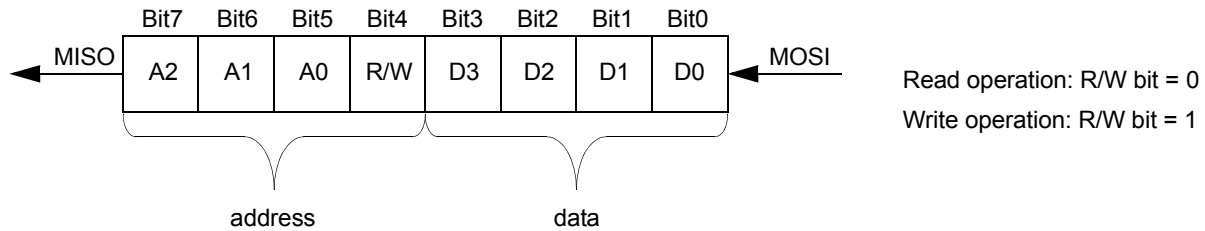

Figure 20. Data Format Description

The SPI is a 8 bit SPI. First 3 bits are used to identify the internal SBC register address, bit 4 is a read/write bit. The last 4 bits are data send from MCU to SBC or read back from SBC to MCU.

During write operation state of MISO has no signification.

During read operation only the last 4 bits at MISO have a meaning (content of the accessed register)

Following tables describe the SPI register list, and register bit meaning.

Registers “reset value” is also described, as well as the “reset condition”. reset condition is the condition which cause the bit to be set at the “reset value”.

Possible reset condition are:

Power On Reset: POR

SBC mode transition:

NR2R - Normal Request to Reset mode

NR2N - Normal Request to Normal mode

N2R - Normal to Reset mode

STB2R - Standby to Reset mode

STO2R - Stop to Reset mode

SBC mode:RESET - SBC in Reset mode

Table 8. List of Registers

Name	Address	Description	Comment and usage
MCR	\$0 0 0	Mode control register	Write: Control of normal, standby, sleep, and stop modes Read: BATFAIL flag and other status bits and flags
RCR	\$0 0 1	Reset control register	Write: Configuration of reset voltage level, WD in stop mode, low power mode selection Read: CAN wake-up event, Tx permanent dominant
CAN	\$0 1 0	CAN control register	Write: CAN module control: TX/RX, Rec only, term VBAT, Normal and extended modes, filter at L0 input. Read: CAN failure status bits
IOR	\$0 1 1	I/O control register	Write: HS1 (high-side switch) control in normal and standby mode. Gnd shift register level selection Read: HS1 over temp bit, SHIFT bit (gnd shift above selection), V _{SUP} below 6.1V, V2 below 4.0 V
WUR	\$1 0 0	Wake-up input register	Write: Control of wake-up input polarity Read: Wake-up input, and real time LX input state
TIM	\$1 0 1	Timing register	Write: TIM1, Watchdog timing control, window or Timeout mode. Write: TIM2, Cyclic sense and force wake-up timing selection
LPC	\$1 1 0	Low power mode control register	Write: HS1 periodic activation in sleep and stop modes Force wake-up control
INTR	\$1 1 1	Interrupt register	Write: Interrupt source configuration Read: INT source

Register description

Table 9. MCR Register

MCR		D3	D2	D1	D0
\$000b	W		MCTR2	MCTR1	MCTR0
	R	BATFAIL	VDDTEMP	GFAIL	WDRST
Reset		0	0	0	0
Reset condition			POR, RESET	POR, RESET	POR, RESET

Table 10. Control bits

MCTR2	MCTR1	MCTR0	SBC MODE	DESCRIPTION
0	0	0	Enter/leave debug mode	To enter debug mode, SBC must be in Normal or Standby mode and BATFAIL ⁽¹⁾ must be still at 1. To leave debug mode, BATFAIL must be at 0.
0	0	1	Normal	
0	1	0	Standby	
0	1	1	Stop, watchdog off ⁽²⁾	

MCTR2	MCTR1	MCTR0	SBC MODE	DESCRIPTION
0	1	1	Stop, watchdog on ⁽²⁾	
1	0	0	Sleep ⁽³⁾	
1	0	1	Normal	No watchdog running, debug mode
1	1	0	Standby	
1	1	1	Stop ⁽⁴⁾	

(1): Bit BATFAIL cannot be set by SPI. BATFAIL is set when V_{SUP} falls below 3V.

(2): Watchdog ON or OFF depends on the RCR register bit D3.

(3): Before entering sleep mode, bit NOSTOP in RCR register must be previously set to 1.

(4): Stop command should be replaced by Stop Watchdog OFF. MCTR2=0, MCTR1= MCTR0=1

Table 11. Status bits

STATUS BIT	DESCRIPTION
GFAIL	Logic OR of CAN failure, HS1 failure, V2LOW
BATFAIL	Battery fail flag ($V_{SUP}<3V$)
VDDTEMP	Temperature pre-warning on VDD (latched)
WDRST	Watchdog reset occurred

Table 12. RCR register

RCR		D3	D2	D1	D0
\$001b	W	WDSTOP	NOSTOP		RSTTH
	R			TXFAILURE	CANWU
Reset		1	0		0
Reset condition		POR, RESET	POR, NR2N		POR

Table 13. Control bits

Status bit	Bit value	Description
WDSTOP	0	No watchdog in stop mode
	1	Watchdog runs in stop mode
NOSTOP	0	Stop mode is default low power mode
	1	Sleep mode is default low power mode
RSTTH	0	Reset threshold 1 selected (typ 4.6V)
	1	Reset threshold 2 selected (typ 4.2V)
CANWU	1	Wake-rom CAN
TXFAILURE	1	Tx permanent dominant (CAN)

Table 14. CAN register

Some description.

CAN		D3	D2	D1	D0
\$010b	W	FDIS	CEXT	CCTR1	CCTR0
	R	CS3	CS2	CS1	CS0
Reset		0	0	0	0
Reset condition		POR, CAN	POR, CAN	POR, CAN	POR, CAN

Fault tolerant CAN transceiver standard modes

The CAN transceiver standard mode can be programmed by setting CEXT to 0. The transceiver cell will then be behave as known from MC33388.

Table 15. CAN Transceiver Modes

CEXT	CCTR1	CCTR0	Mode
0	0	0	TermVBAT
0	0	1	
0	1	0	RxOnly
0	1	1	RxTx

Table 16. CAN transceiver extended modes (CAN with CEXT bit =1 is not recommended)

CEXT ⁽¹⁾	CCTR1	CCTR0	Mode
1	0	0	TermVBAT
1	0	1	TermVDD
1	1	0	RxOnly
1	1	1	RxTx

Fault tolerant CAN transceiver extended modes

By setting CEXT to 1 the transceiver cell supports sub bus communication

Note1: CEXT Bit should be set at 0. The CAN operation in extended mode is not recommended.

FDIS	L0 wake input filter (20 μ s typical)
0	Enable (L0 wake threshold selectable by WUR register)
1	Disable (L0 wake-up threshold is low level only, no matter D0 and D1 bits set in WUR register).

Note: if DFIS bit is set to 1, WUR register must be read before going into sleep or stop mode in order to clear the wake-up flag. During read out L0 must be at high level and should stay high when entering sleep or stop.

Table 17. Status bits

CS3	CS2	CS1	CS0	Bus failure #		Description
0	0	0	0		no failure	
0	0	0	1	1	CANH open wire	
0	1	0	1	5	CANH short circuit to	ground
0	1	1	0	8, 3a		VDD
0	1	1	1	3		VBAT
1	0	0	1	2	CANL open wire	
1	1	0	1	4, 7	CANL short circuit to	ground / CANH
1	1	1	0	9		VDD
1	1	1	1	6		VBAT

Comments:

CS2 bit at 0 = open failure. CS2 bit at 1 = short failure.

(CS3 bit at 0 and (CS1 = 1 or CS2 =1)) = CANH failure. CS3 bit at 1 = CANL failure.

CS1 and CS0 bits: short type failure coding (gnd, VDD or VBAT).

In case of multiple failures, the last failure is reported.

Table 18. IOR register.

IOR		D3	D2	D1	D0
\$011b	W		HS1ON	GSLR1	GSLR0
	R	SHIFT	HS1OT	V2LOW	VSUPLOW
Reset			0	0	0
Reset condition			POR, RESET	POR, RESET	POR, RESET

Table 19. Control bits

HS1ON	HS1
0	HS1 switch turn OFF
1	HS1 switch turn ON

Table 20. Gnd shift selection

GSLR1	GSLR0	Typical gnd shift comparator level
0	0	-0.3 V
0	1	-0.7 V
1	0	-1.2 V
1	1	-1.7 V

Shift	State
0	Gnd shift value is lower than the level selected by the GSLR1 and GSLR2 bit
1	Gnd shift value is higher than the level selected by the GSLR1 and GSLR2 bit

Table 21. Status bits

Status bit	Description
HS1OT (*)	High-side 1 over temperature
SHIFT	gnd shift level selected by GSLR1 and GSLR2 bits is reached
V2LOW	V2 below 4.0 V typical
VSUPLOW	V _{SUP} below 6.1 V typical

(*) Once the HS1 switch has been turned off because of over temperature, it can be turned on again by setting the appropriate control bit to "1".

WUR REGISTER

The local wake-up inputs L0 and L1 can be used in both normal and standby mode as port expander and for waking up the SBC in sleep or stop mode.

Table 22. WUR Register

WUR		D3	D2	D1	D0
\$100b	W	LCTR3	LCTR2	LCTR1	LCTR0
	R	L1WUb	L1WUa	L0WUb	L0WUa
Reset		1	1	1	1
Reset condition		POR, NR2R, N2R, STB2R, STO2R			

Table 23. Control bits:.

LCTR3	LCTR2	LCTR1	LCTR0	L0 configuration	L1 configuration
X	X	0	0	inputs disabled	
X	X	0	1	high level sensitive	
X	X	1	0	low level sensitive	
X	X	1	1	both level sensitive	
0	0	X	X		inputs disabled
0	1	X	X		high level sensitive
1	0	X	X		low level sensitive
1	1	X	X		both level sensitive

Table 24. Status bits

LOWUb	LOWUa	FDIS bit in CAN register	Description
0	0	0	No wake-up occurred at L0 (sleep or stop mode). Low level state on L0 (standby or normal mode)
1	1	0	Wake-up occurred at L0 (sleep or stop mode). High level state on L0 (standby or normal mode)
0	1	1	Wake-up occurred at L0 (sleep or stop mode with L0 filter disable). WUR must be set to xx00 before sleep or stop mode.

L1WUb	L1WUa	Description
0	0	No wake-up occurred at L1 (sleep or stop mode). Low level state on L1 (standby or normal mode)
1	1	Wake-up occurred at L1 (sleep or stop mode). High level state on L1 (standby or normal mode)

TIM REGISTERS

Description: This register is split into 2 sub registers, TIM1 and TIM2.

TIM1 controls the watchdog timing selection as well as the window or timeout option. TIM1 is selected when bit D3 is 0.

TIM2 is used to define the timing for the cyclic sense and forced wake-up function. TIM2 is selected when bit D3 is 1.

No read operation is allowed for registers TIM1 and TIM2

TIM REGISTER

Table 25. TIM Register.

TIM1		D3	D2	D1	D0
\$101b	W	0	WDW	WDT1	WDT0
	R				
Reset			0	0	0
Reset condition			POR, RESET	POR, RESET	POR, RESET

Table 26. Watch dog

WDW	WDT1	WDT0	Watchdog timing [ms]	
0	0	0	10	no window watchdog
0	0	1	50	
0	1	0	100	
0	1	1	350	
1	0	0	10	window watchdog enabled (window length is half the watchdog timing)
1	0	1	50	
1	1	0	100	
1	1	1	350	

Table 27. jWatchdog operation (window and timeout)

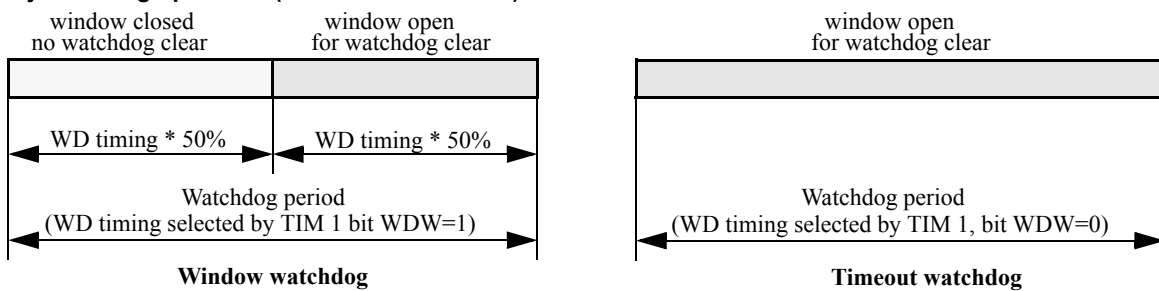

TIM2 REGISTER

The purpose of TIM2 register is to select an appropriate timing for sensing the wake-up circuitry or cyclically supplying devices by switching on or off HS1

Table 28. TIM2 Register

TIM2		D3	D2	D1	D0
\$101b	W	1	CSP2	CSP1	CSP0
	R				
Reset			0	0	0
Reset condition			POR, RESET	POR, RESET	POR, RESET

Table 29. Cyclic Sense Timing

CSP2	CSP1	CSP0	Cyclic sense timing [ms]
0	0	0	5
0	0	1	10
0	1	0	20
0	1	1	40
1	0	0	75
1	0	1	100
1	1	0	200
1	1	1	400

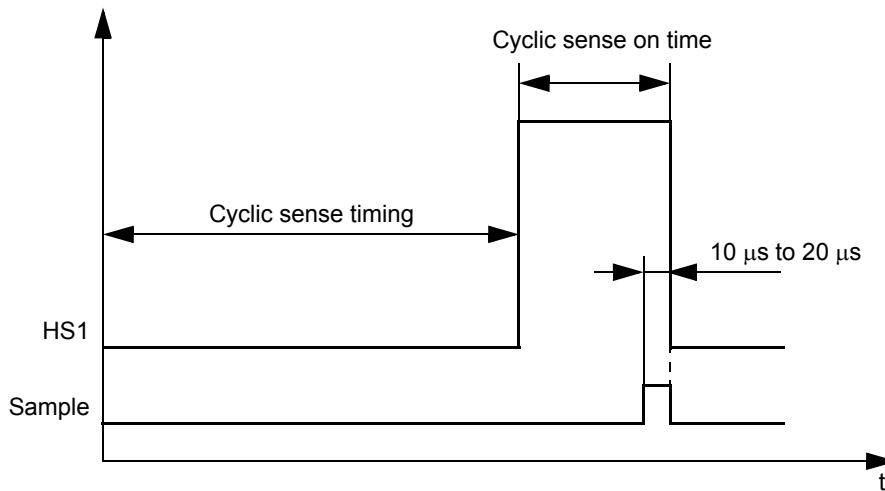

LPC REGISTER

Description: This register controls:

- The state of HS1 in stop and sleep mode (HS1 permanently off or HS1 cyclic)
- Enable or Disable the forced wake-up function (SBC automatic wake-up after time spend in sleep or stop mode, time defined by TIM2 register)
- Enable or disable the sense of the wake-up inputs (LX) at sampling point of the cyclic sense period (LX2HS1 bit).

Table 30. LPC Register

LPC		D3	D2	D1	D0
\$110b	W	LX2HS1	FWU	IDDS	HS1AUTO
	R				
Reset		0	0	0	0
Reset condition		POR, NR2R, N2R, STB2R, STO2R	POR, NR2R, N2R, STB2R, STO2R	POR, NR2R, N2R, STB2R, STO2R	POR, NR2R, N2R, STB2R, STO2R

LX2HS1	HS1AUTO	Wake-up inputs supplied by HS1	Autotiming HS1
X	0		off
X	1		On, HS1 cyclic, period defined in TIM2 register
0	X	no	
1	X	Yes, LX inputs sensed at sampling point	

Bit	Description
FWU	If this bit is set, and the SBC is turned into sleep or stop mode, the SBC wakes up after the time selected in the TIM2 register
IDDS	Bit = 0: I _{DDS-WU1} selected (lowest value, typ 3.5mA) Bit = 1: I _{DDS-WU2} selected (highest value, typ 14mA)

Table 31. INTR register

INTR		D3	D2	D1	D0
\$111b	W	VSUPLOW	HS1OT-V2LOW	VDDTEMP	CANF
	R	VSUPLOW	HS1OT	VDDTEMP	CANF
Reset		0	0	0	0
Reset condition		POR, RESET	POR, RESET	POR, RESET	POR, RESET

Table 32. Control bits:

Control bit	Description
CANF	Mask bit for CAN failures (OR of any CAN failure)
VDDTEMP	Mask bit for VDD medium temperature
HS1OT-V2LOW	Mask bit for HS1 over temperature OR V2 below 4V
VSUPLOW	Mask bit for SUP below 6.1V

When the mask bit has been set, $\overline{\text{INT}}$ pin goes low if the appropriate condition occurs.

Table 33. Status bits:

Status bit	Description
CANF	CAN failure
VDDTEMP	VDD medium temperature
HS1OT	HS1 over temperature
VSUPLOW	V _{SUP} below 6.1V typical

Notes:

If HS1OT-V2LOW interrupt is only selected (only bit D2 set in INTR register), reading INTR register bit D2 leads to two possibilities:

Bit D2 = 1: INT source is HS1OT

Bit D2 = 0: INT source is V2LOW.

Upon a wake-up condition from stop mode due to over current detection (I_{DD1S-WU1} or I_{DD1S-WU2}), an INT pulse is generated, however INTR register contain remains at 0000 (not bit set into the INTR register).

TYPICAL APPLICATIONS

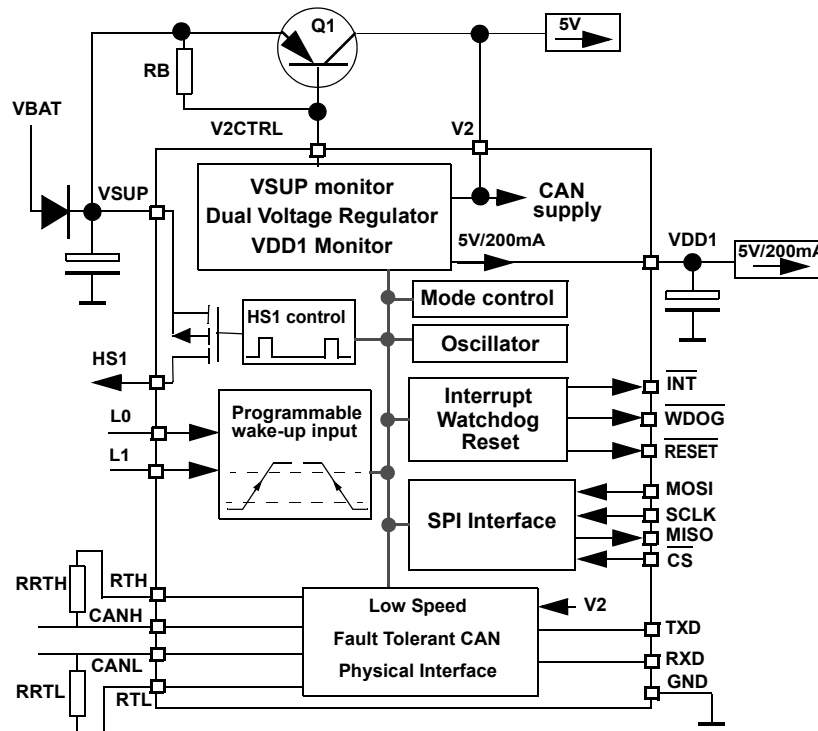

Figure 21. 33889D/33889B Simplified Typical Application with Ballast Transistor

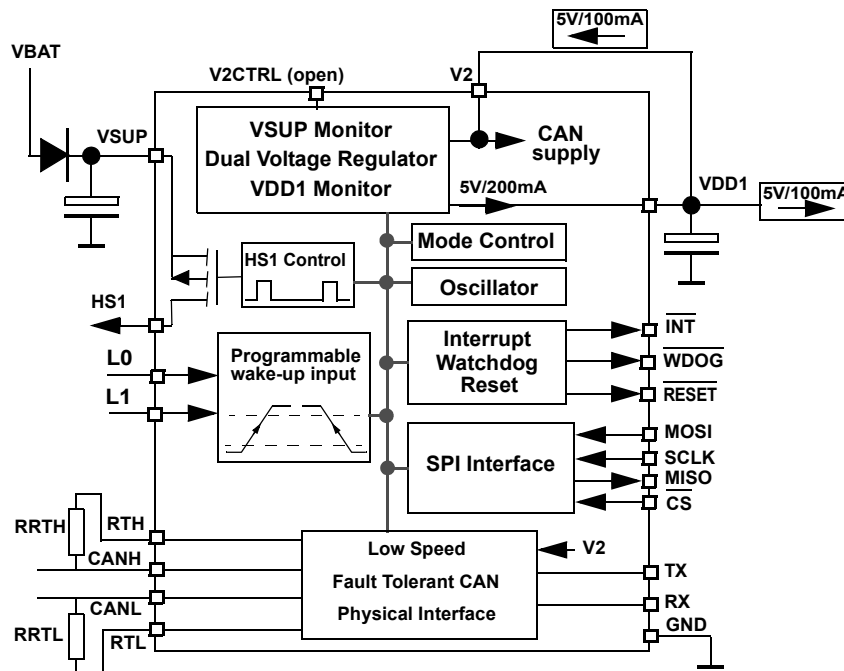
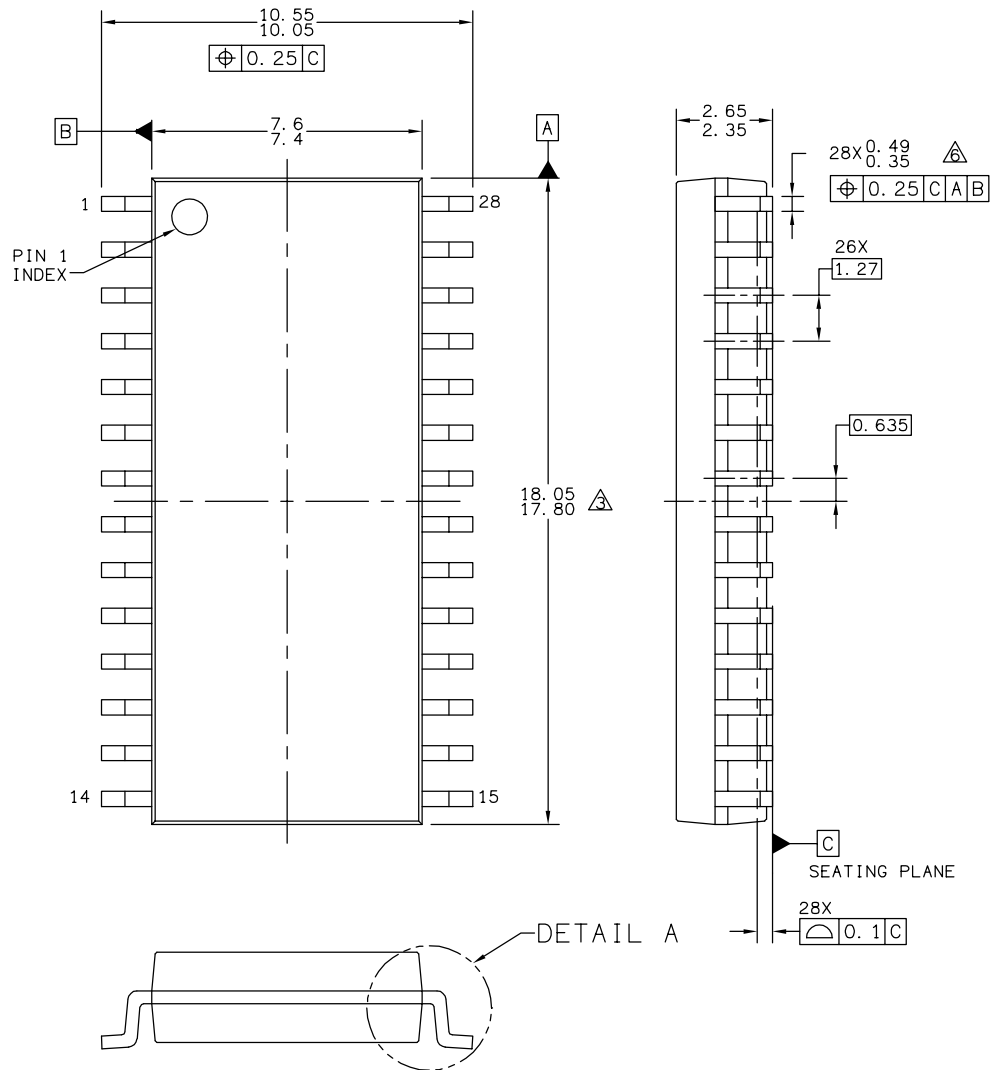

Figure 22. 33889D/33889B Simplified Typical Application without Ballast Transistor

PACKAGING

PACKAGE DIMENSIONS

Important For the most current revision of the package, visit www.freescale.com and do a keyword search on the 98A number listed below.



© FREESCALE SEMICONDUCTOR, INC. ALL RIGHTS RESERVED.	MECHANICAL OUTLINE	PRINT VERSION NOT TO SCALE	
TITLE: SOIC, WIDE BODY, 28 LEAD CASEOUTLINE	DOCUMENT NO: 98ASB42345B	REV: G	
	CASE NUMBER: 751F-05	10 MAR 2005	
	STANDARD: MS-013AE		

DW SUFFIX
EG SUFFIX (PB-FREE)
28-PIN
PLASTIC PACKAGE
98ASB42345B
ISSUE G

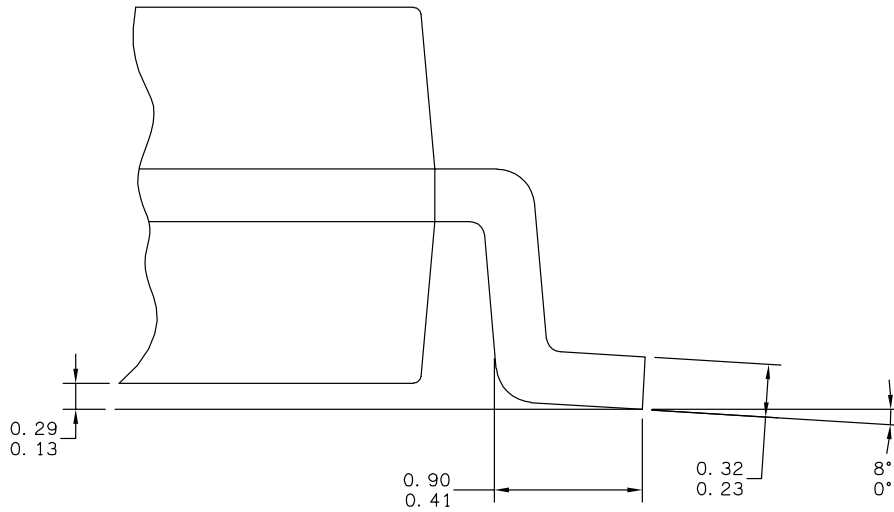

© FREESCALE SEMICONDUCTOR, INC. ALL RIGHTS RESERVED.	MECHANICAL OUTLINE	PRINT VERSION NOT TO SCALE	
TITLE: SOIC, WIDE BODY, 28 LEAD CASEOUTLINE	DOCUMENT NO: 98ASB42345B	REV: G	
	CASE NUMBER: 751F-05	10 MAR 2005	
	STANDARD: MS-013AE		

DW SUFFIX
EG SUFFIX (PB-FREE)
28-PIN
PLASTIC PACKAGE
98ASB42345B
ISSUE G

ADDITIONAL DOCUMENTATION

THERMAL ADDENDUM (REV 2.0)

Introduction

This thermal addendum is provided as a supplement to the MC33889 technical datasheet. The addendum provides thermal performance information that may be critical in the design and development of system applications. All electrical, application, and packaging information is provided in the datasheet.

Packaging and Thermal Considerations

The MC33889 is offered in a 28 pin SOICW, single die package. There is a single heat source (P), a single junction temperature (T_J), and thermal resistance (R_{θJA}).

$$\{ T_J \} = [R_{\theta JA}] \cdot \{ P \}$$

The stated values are solely for a thermal performance comparison of one package to another in a standardized environment. This methodology is not meant to and will not predict the performance of a package in an application-specific environment. Stated values were obtained by measurement and simulation according to the standards listed below.

Standards

Table 34. Thermal Performance Comparison

Thermal Resistance	[°C/W]
P _{θJA} ^{(1) (2)}	42
P _{θJB} ^{(2) (3)}	11
P _{θJA} ^{(1) (4)}	69
P _{θJX} ⁽⁵⁾	23

Notes

- Per JEDEC JESD51-2 at natural convection, still air condition.
- 2s2p thermal test board per JEDEC JESD51-7.
- Per JEDEC JESD51-8, with the board temperature on the center trace near the center lead.
- Single layer thermal test board per JEDEC JESD51-3.
- Thermal resistance between the die junction and the package top surface; cold plate attached to the package top surface and remaining surfaces insulated.

33889DW
33889EG

28-PIN
SOICW

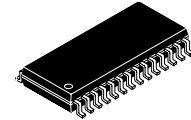

DWB SUFFIX
EG SUFFIX (PB-FREE)
98ASB42345
28-PIN SOICW

**NOTE FOR PACKAGE DIMENSIONS,
 REFER TO THE 33889 DEVICE DATASHEET.**

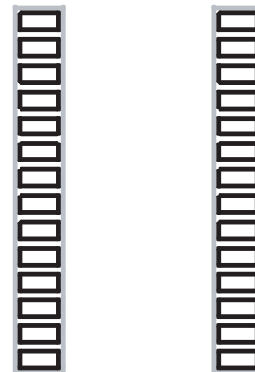

20 Terminal SOICW
 1.27 mm Pitch
 18.0 mm x 7.5 mm Body

**Figure 23. Surface Mount for SOIC Wide Body
 Non-Exposed Pad**

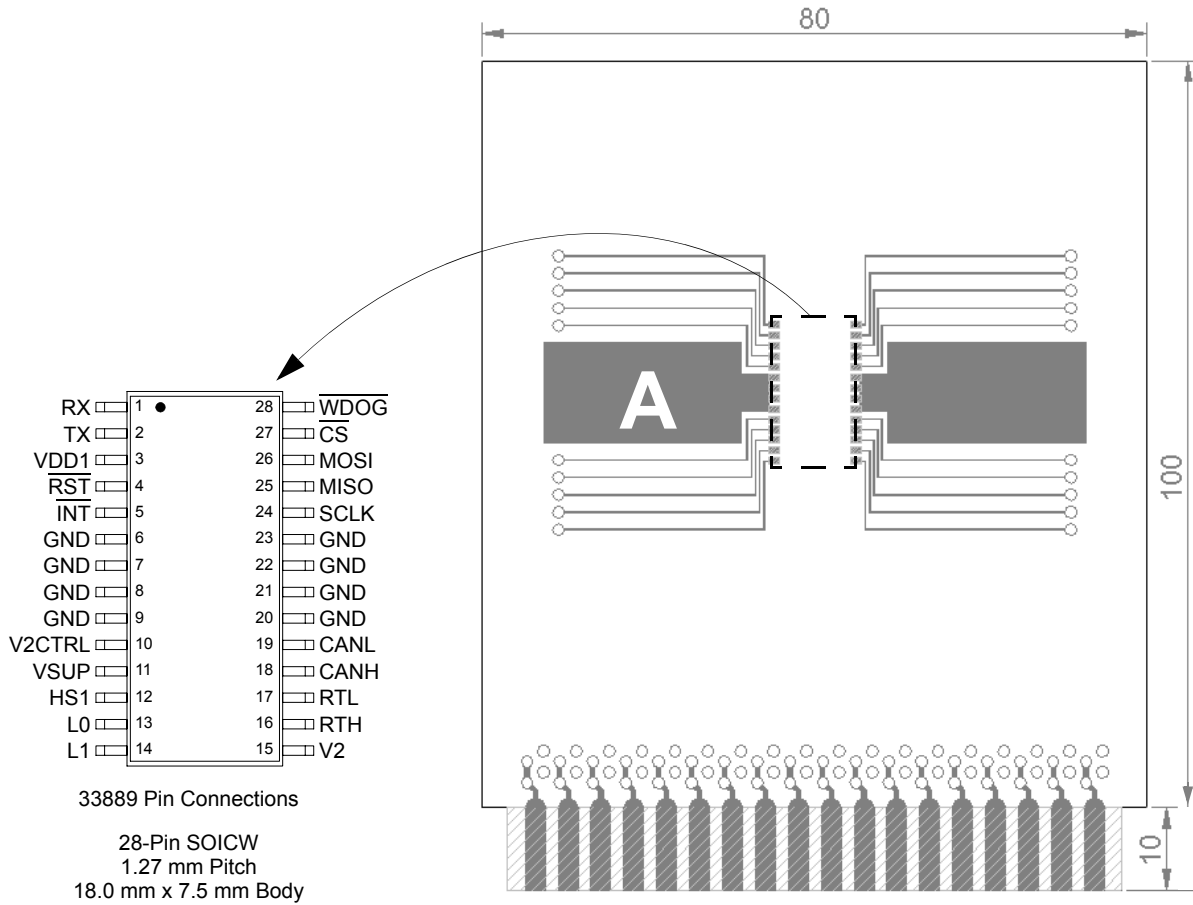

Figure 24. Thermal Test Board

Device on Thermal Test Board

- Material: Single layer printed circuit board
FR4, 1.6 mm thickness
Cu traces, 0.07 mm thickness
- Outline: 80 mm x 100 mm board area,
including edge connector for thermal
testing
- Area A: Cu heat-spreading areas on board
surface
- Ambient Conditions: Natural convection, still air

Table 35. Thermal Resistance Performance

Thermal Resistance	Area A (mm ²)	(°C/W)
$R_{\theta JA}$	0	69
	300	53
	600	48

$R_{\theta JA}$ is the thermal resistance between die junction and ambient air.

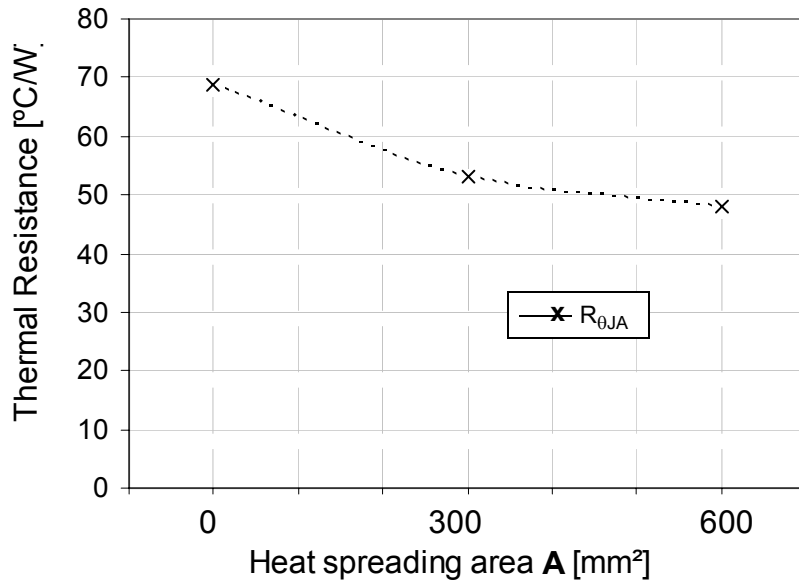

Figure 25. Device on Thermal Test Board $R_{\theta JA}$

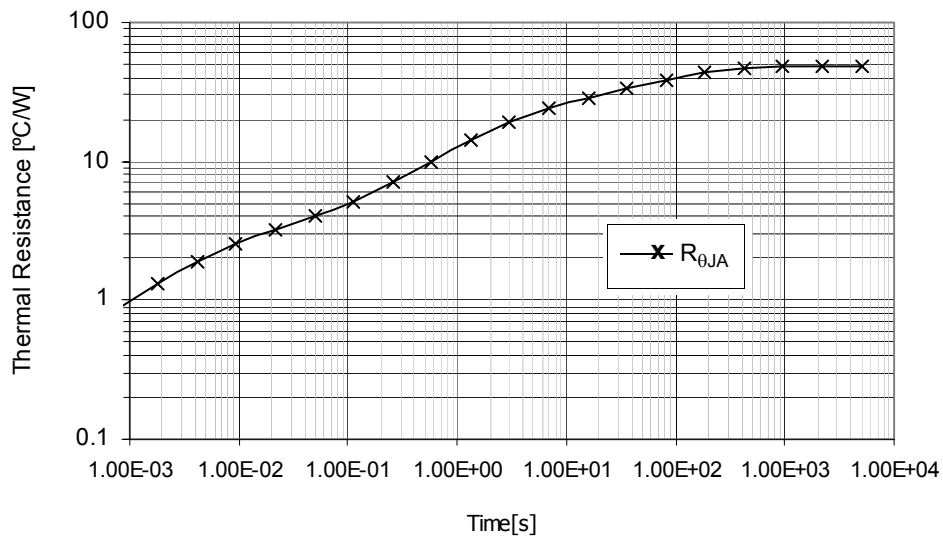

Figure 26. Transient Pin Resistance $R_{\theta JA}$
 Device on Thermal Test Board Area $A = 600$ (mm²)

REVISION HISTORY

REVISION	DATE	DESCRIPTION OF CHANGES
7.0	5/2006	<ul style="list-style-type: none"> • Implemented Revision History page • Added “EG” PB-Free package type • Removed MC33889DW version, and added MC33889B and MC33889D versions • Converted to the Freescale format, and updated to the prevailing form and style • Modified Device Variations Between the 33889D and 33889B Versions ⁽¹⁾ on page 2 • Added Thermal Addendum (rev 2.0) on page 56 • Changed the Maximum Ratings on page 6 to the standard format • Added CAN transceiver description section
8.0	6/2002	<ul style="list-style-type: none"> • Corrected two instances where pin LO had an overline, and one instance where pin WDOG did not.
9.0	8/2006	<ul style="list-style-type: none"> • Removed MC33889BEG/R2 and MC33889DEG/R2 and replaced them with MCZ33889BEG/R2 and MCZ33889DEG/R2 in the Ordering Information block
10.0	9/2006	<ul style="list-style-type: none"> • Replaced the label Logic Inputs with Logic Signals (RX, TX, MOSI, MISO, CS, SCLK, RST, WDOG, INT) on page 6 • Changed CS to $\overline{\text{CS}}$ at various places in the document
11.0	12/2006	<ul style="list-style-type: none"> • Made changes to Supply Current in Stand-by Mode ^{(7),(9)} on page 8 and Supply Current in Normal Mode ⁽⁷⁾ on page 8
12.0	3/2007	<ul style="list-style-type: none"> • Added the EG suffix to the included thermal addendum

How to Reach Us:

Home Page:

www.freescale.com

Web Support:

<http://www.freescale.com/support>

USA/Europe or Locations Not Listed:

Freescale Semiconductor, Inc.
Technical Information Center, EL516
2100 East Elliot Road
Tempe, Arizona 85284
+1-800-521-6274 or +1-480-768-2130
www.freescale.com/support

Europe, Middle East, and Africa:

Freescale Halbleiter Deutschland GmbH
Technical Information Center
Schatzbogen 7
81829 Muenchen, Germany
+44 1296 380 456 (English)
+46 8 52200080 (English)
+49 89 92103 559 (German)
+33 1 69 35 48 48 (French)
www.freescale.com/support

Japan:

Freescale Semiconductor Japan Ltd.
Headquarters
ARCO Tower 15F
1-8-1, Shimo-Meguro, Meguro-ku,
Tokyo 153-0064
Japan
0120 191014 or +81 3 5437 9125
support.japan@freescale.com

Asia/Pacific:

Freescale Semiconductor Hong Kong Ltd.
Technical Information Center
2 Dai King Street
Tai Po Industrial Estate
Tai Po, N.T., Hong Kong
+800 2666 8080
support.asia@freescale.com

For Literature Requests Only:

Freescale Semiconductor Literature Distribution Center
P.O. Box 5405
Denver, Colorado 80217
1-800-441-2447 or 303-675-2140
Fax: 303-675-2150
LDCForFreescaleSemiconductor@hibbertgroup.com

RoHS-compliant and/or Pb-free versions of Freescale products have the functionality and electrical characteristics of their non-RoHS-compliant and/or non-Pb-free counterparts. For further information, see <http://www.freescale.com> or contact your Freescale sales representative.

For information on Freescale's Environmental Products program, go to <http://www.freescale.com/epp>.

Information in this document is provided solely to enable system and software implementers to use Freescale Semiconductor products. There are no express or implied copyright licenses granted hereunder to design or fabricate any integrated circuits or integrated circuits based on the information in this document.

Freescale Semiconductor reserves the right to make changes without further notice to any products herein. Freescale Semiconductor makes no warranty, representation or guarantee regarding the suitability of its products for any particular purpose, nor does Freescale Semiconductor assume any liability arising out of the application or use of any product or circuit, and specifically disclaims any and all liability, including without limitation consequential or incidental damages. "Typical" parameters that may be provided in Freescale Semiconductor data sheets and/or specifications can and do vary in different applications and actual performance may vary over time. All operating parameters, including "Typicals", must be validated for each customer application by customer's technical experts. Freescale Semiconductor does not convey any license under its patent rights nor the rights of others. Freescale Semiconductor products are not designed, intended, or authorized for use as components in systems intended for surgical implant into the body, or other applications intended to support or sustain life, or for any other application in which the failure of the Freescale Semiconductor product could create a situation where personal injury or death may occur. Should Buyer purchase or use Freescale Semiconductor products for any such unintended or unauthorized application, Buyer shall indemnify and hold Freescale Semiconductor and its officers, employees, subsidiaries, affiliates, and distributors harmless against all claims, costs, damages, and expenses, and reasonable attorney fees arising out of, directly or indirectly, any claim of personal injury or death associated with such unintended or unauthorized use, even if such claim alleges that Freescale Semiconductor was negligent regarding the design or manufacture of the part.

Freescale™ and the Freescale logo are trademarks of Freescale Semiconductor, Inc. All other product or service names are the property of their respective owners.

© Freescale Semiconductor, Inc., 2007. All rights reserved.