

Π2/4, Π4/6 Clock Generation Chip

The MC100LVEL39 is a low skew Π2/4, Π4/6 clock generation chip designed explicitly for low skew clock generation applications. The MC100EL39 is pin and functionally equivalent to the MC100LVEL39 but is specified for operation at the standard 100K ECL voltage supply. The internal dividers are synchronous to each other, therefore, the common output edges are all precisely aligned. The device can be driven by either a differential or single-ended LVECL or, if positive power supplies are used, LVPECL input signal. In addition, by using the V_{BB} output, a sinusoidal source can be AC coupled into the device (see Interfacing section of the ECLinPSE Data Book DL140/D). If a single-ended input is to be used, the V_{BB} output should be connected to the CLK input and bypassed to ground via a 0.01μF capacitor. The V_{BB} output is designed to act as the switching reference for the input of the LVEL39 under single-ended input conditions, as a result, this pin can only source/sink up to 0.5mA of current.

The common enable (\overline{EN}) is synchronous so that the internal dividers will only be enabled/disabled when the internal clock is already in the LOW state. This avoids any chance of generating a runt clock pulse on the internal clock when the device is enabled/disabled as can happen with an asynchronous control. An internal runt pulse could lead to losing synchronization between the internal divider stages. The internal enable flip-flop is clocked on the falling edge of the input clock, therefore, all associated specification limits are referenced to the negative edge of the clock input.

Upon startup, the internal flip-flops will attain a random state; therefore, for systems which utilize multiple LVEL39s, the master reset (MR) input must be asserted to ensure synchronization. For systems which only use one LVEL39, the MR pin need not be exercised as the internal divider design ensures synchronization between the Π2/4 and the Π4/6 outputs of a single device.

- ω 50ps Output-to-Output Skew
- ω Synchronous Enable/Disable
- ω Master Reset for Synchronization
- ω 75kΩ Internal Input Pulldown Resistors
- ω >2000V ESD Protection
- ω Low Voltage V_{EE} Range of -3.0 to -3.8V

Pinout: 20-Lead SOIC (Top View)

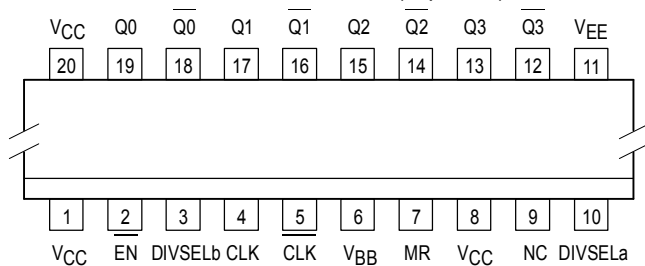

MC100LVEL39 MC100EL39

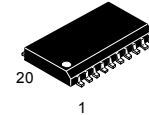

DW SUFFIX
PLASTIC SOIC PACKAGE
CASE 751D-04

PIN DESCRIPTION

PIN	FUNCTION
CLK	Diff Clock Inputs
EN	Sync Enable
MR	Master Reset
V _{BB}	Reference Output
Q ₀ , Q ₁	Diff Π2/4 Outputs
Q ₂ , Q ₃	Diff Π4/6 Outputs
DIVSEL	Frequency Select Input

FUNCTION TABLE

CLK	\overline{EN}	MR	FUNCTION
Z	L	L	Divide
ZZ	H	L	Hold Q ₀₋₃
X	X	H	Reset Q ₀₋₃

Z = Low-to-High Transition
ZZ = High-to-Low Transition

DIVSEL _a	Q ₀ , Q ₁ OUTPUTS
0	Divide by 2
1	Divide by 4
DIVSEL _b	Q ₂ , Q ₃ OUTPUTS
0	Divide by 4
1	Divide by 6



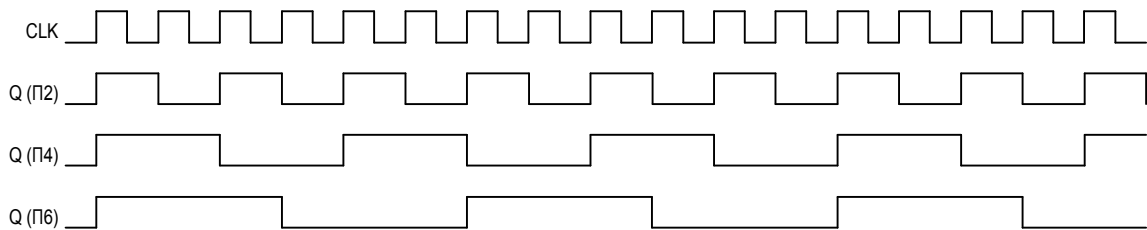
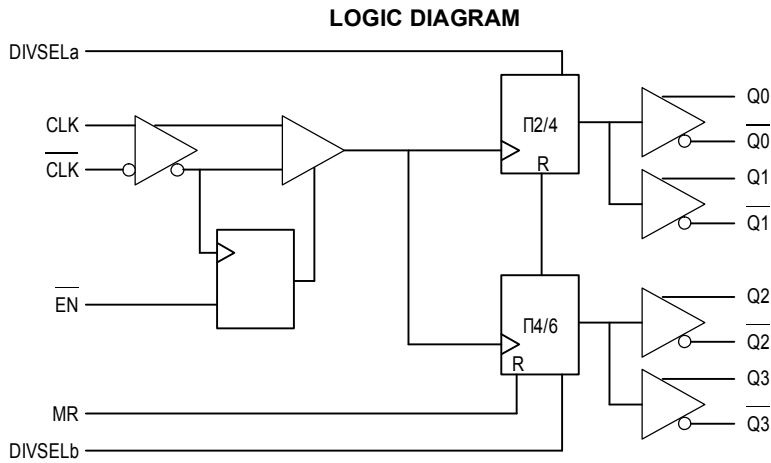

Figure 1. Timing Diagrams

MC100LVEL39

DC CHARACTERISTICS ($V_{EE} = -3.8V$ to $-3.0V$; $V_{CC} = GND$)

Symbol	Characteristic	-40°C			0°C			25°C			85°C			Unit
		Min	Typ	Max	Min	Typ	Max	Min	Typ	Max	Min	Typ	Max	
I_{EE}	Power Supply Current		50	59		50	59		50	59		54	61	mA
V_{BB}	Output Reference Voltage	-1.38		-1.26	-1.38		-1.26	-1.38		-1.26	-1.38		-1.26	V
I_{IH}	Input High Current			150			150			150			150	μA

MC100LVEL39

AC CHARACTERISTICS ($V_{EE} = -3.8V$ to $-3.0V$; $V_{CC} = GND$)

Symbol	Characteristic	-40°C			0°C			25°C			85°C			Unit
		Min	Typ	Max	Min	Typ	Max	Min	Typ	Max	Min	Typ	Max	
f_{MAX}	Maximum Toggle Frequency	1000			1000			1000			1000			MHz
t_{PLH} t_{PHL}	Propagation Delay to Output	760 710 600		960 1010 900	780 730 600		980 1030 900	800 750 610		1000 1050 910	850 800 630		1050 1100 930	ps
t_{SKEW}	Within-Device Skew ¹			50			50			50			50	ps
	Part-to-Part			200			200			200			200	
t_S	Setup Time	250 400			250 400			250 400			250 400			ps
t_H	Hold Time	100			100			100			100			ps
		150			150			150			150			

MC100LVEL39 (continued)

AC CHARACTERISTICS ($V_{EE} = -3.8V$ to -3.0 ; $V_{CC} = GND$)

Symbol	Characteristic	-40°C			05°C			25°C			85°C			Unit
		Min	Typ	Max	Min	Typ	Max	Min	Typ	Max	Min	Typ	Max	
V_{PP}	Minimum Input Swing CLK	250			250			250			250			mV
V_{CMR}	Common Mode Range ³ $V_{PP} < 500mV$ $V_{PP} = 500mV$	-2.0 -1.8		-0.4 -0.4	-2.1 -1.9		-0.4 -0.4	-2.1 -1.9		-0.4 -0.4	-2.1 -1.9		-0.4 -0.4	V
t_{RR}	Reset Recovery Time			100			100			100			100	ps
t_{PW}	Minimum Pulse Width CLK MR	500 700			500 700			500 700			500 700			ps
t_r, t_f	Output Rise/Fall Times Q (20% – 80%)	280		550	280		550	280		550	280		550	ps

1. Skew is measured between outputs under identical transitions.

2. Minimum input swing for which AC parameters are guaranteed. The device will function reliably with differential inputs down to 100mV.

3. The CMR range is referenced to the most positive side of the differential input signal. Normal operation is obtained if the HIGH level falls within the specified range and the peak-to-peak voltage lies between V_{ppmin} and 1V. The lower end of the CMR range varies 1:1 with V_{EE} . The numbers in the spec table assume a nominal $V_{EE} = -3.3V$. Note for PECL operation, the $V_{CMR(min)}$ will be fixed at $3.3V - |V_{CMR(min)}|$.

MC100EL39

DC CHARACTERISTICS ($V_{EE} = -4.2V$ to -5.46 ; $V_{CC} = GND$)

Symbol	Characteristic	-40°C			05°C			25°C			85°C			Unit
		Min	Typ	Max	Min	Typ	Max	Min	Typ	Max	Min	Typ	Max	
I_{EE}	Power Supply Current		50	59		50	59		50	59		54	61	mA
V_{BB}	Output Reference Voltage	-1.38		-1.26	-1.38		-1.26	-1.38		-1.26	-1.38		-1.26	V
I_{IH}	Input High Current			150			150			150			150	μA

MC100EL39

AC CHARACTERISTICS ($V_{EE} = -4.2V$ to -5.46 ; $V_{CC} = GND$)

Symbol	Characteristic	-40°C			05°C			25°C			85°C			Unit
		Min	Typ	Max	Min	Typ	Max	Min	Typ	Max	Min	Typ	Max	
f_{MAX}	Maximum Toggle Frequency	1000			1000			1000			1000			MHz
t_{PLH} t_{PHL}	Propagation Delay CLK ∇ Q (Diff) to Output CLK ∇ Q (S.E.) MR ∇ Q	760 710 600		960 1010 900	780 730 600		980 1030 900	800 750 610		1000 1050 910	850 800 630		1050 1100 930	ps
t_{SKEW}	Within-Device Skew ¹ $Q_0 - Q_3$ Part-to-Part $Q_0 - Q_3$ (Diff)			50			50			50			50	ps
t_S	Setup Time EN ∇ CLK DIVSEL ∇ CLK	250 400			250 400			250 400			250 400			ps
t_H	Hold Time CLK ∇ EN CLK ∇ Div_Sel	100 150			100 150			100 150			100 150			ps
V_{PP}	Minimum Input Swing CLK	250			250			250			250			mV
V_{CMR}	Common Mode Range ³ $V_{PP} < 500mV$ $V_{PP} = 500mV$	-3.2 -3.0		-0.4 -0.4	-3.3 -3.1		-0.4 -0.4	-3.3 -3.1		-0.4 -0.4	-3.3 -3.1		-0.4 -0.4	V
t_{RR}	Reset Recovery Time			100			100			100			100	ps
t_{PW}	Minimum Pulse Width CLK MR	500 700			500 700			500 700			500 700			ps
t_r, t_f	Output Rise/Fall Times Q (20% – 80%)	280		550	280		550	280		550	280		550	ps

1. Skew is measured between outputs under identical transitions.

2. Minimum input swing for which AC parameters are guaranteed. The device will function reliably with differential inputs down to 100mV.

3. The CMR range is referenced to the most positive side of the differential input signal. Normal operation is obtained if the HIGH level falls within the specified range and the peak-to-peak voltage lies between V_{ppmin} and 1V. The lower end of the CMR range varies 1:1 with V_{EE} . The numbers in the spec table assume a nominal $V_{EE} = -4.5V$. Note for PECL operation, the $V_{CMR(min)}$ will be fixed at $5.0V - |V_{CMR(min)}|$.

