

# FUJITSU

## CMOS 1,048,576 BIT UV ERASABLE READ ONLY MEMORY (EPROM)

**MBM27C1001-15**  
**MBM27C1001-20**  
**MBM27C1001-25**

April 1988  
Edition 2.0

### CMOS 1,048,576 BIT UV ERASABLE READ ONLY MEMORY (EPROM)

The Fujitsu MBM27C1001 EPROM is a high speed read-only static memory that is UV-erasable and reprogrammable. The device contains 1,048,576 programmable or reprogrammable bits organized in a 131,072-byte/8-bit format. The MBM27C1001 is housed in a 32-pin DIP and 36-pad LCC with a transparent lid; when the lid is properly exposed to an ultraviolet light source, a previously programmed bit pattern is erased in approximately 15-to-21 minutes. A new bit pattern can then be written into memory.

The MBM27C1001 EPROM is fabricated using CMOS double poly-silicon gate technology with stacked single-transistor gate cells. The MBM27C1001 is an excellent choice for system development work and in other applications where program changes are frequently necessary. Once programmed, the device requires only a single +5V power supply; the current requirements are exceptionally low in both the active and standby modes of operation.

- 131,072-byte/8-bit organization with on-chip decoding
- Single-byte or four-byte programming capability with Quick Pro™ algorithm
- Static operation (no clocks required)
- Upward compatible with 256K/512K EPROMS
- Fast access time:
  - MBM27C1001-15 = 150 ns (max)
  - MBM27C1001-20 = 200 ns (max)
  - MBM27C1001-25 = 250 ns (max)
- Easy and simple memory expansion via @pin
- Three-state output for wired-OR capability
- TTL-compatible inputs/outputs
- Single =5V (+10%) power supply with low current drain:
  - Active operation = 30 mA (max) for 200ns/250ns
  - 40 mA (max) for 150ns
  - Standby operation = 0.1 mA (max)
- Programming voltage: +12.5V
- JEDEC-approved pin assignments
- 32-pin CERDIP

#### ABSOLUTE MAXIMUM RATINGS (see NOTE)

Rating	Symbol	Value	Unit
Supply Voltage with respect to ground	V <sub>CC</sub>	-0.6 to +7.0	V
Programming Voltage with respect to ground	V <sub>PP</sub>	-0.6 to +14.0	V
Input/Output Voltage (except for A <sub>9</sub> with respect to ground)	V <sub>IN1</sub>	-0.6 to V <sub>CC</sub> + 0.3	V
Programming Voltage with respect to ground	V <sub>IN2</sub>	-0.6 to +13.5	V
Temperature under Bias	T <sub>BIAS</sub>	-25 to +85	°C
Storage Temperature Range	T <sub>STG</sub>	-65 to +125	°C

NOTE: Permanent device damage may occur if the above Absolute Maximum Ratings are exceeded. Functional operation should be restricted to the conditions as detailed in the operational sections of this data sheet. Exposure to absolute maximum rating conditions for extended periods may affect device reliability.

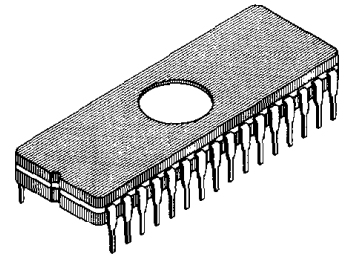

CERAMIC PACKAGE  
DIP-32C-C01

LCC-36C-F01 See Page 11

4

#### PIN ASSIGNMENT

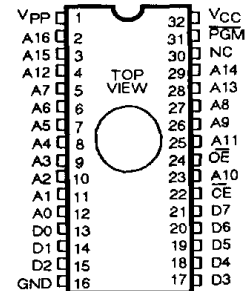

This device contains circuitry to protect the inputs against damage due to high static voltages or electric fields. However, it is advised that normal precautions be taken to avoid application of any voltage higher than maximum rated voltages to this high impedance circuit.

Quick Pro™ is a trademark of FUJITSU LIMITED

Copyright © 1988 by FUJITSU LIMITED and Fujitsu Microelectronics, Inc.



MBM27C1001-15  
 MBM27C1001-20  
 MBM27C1001-25

4

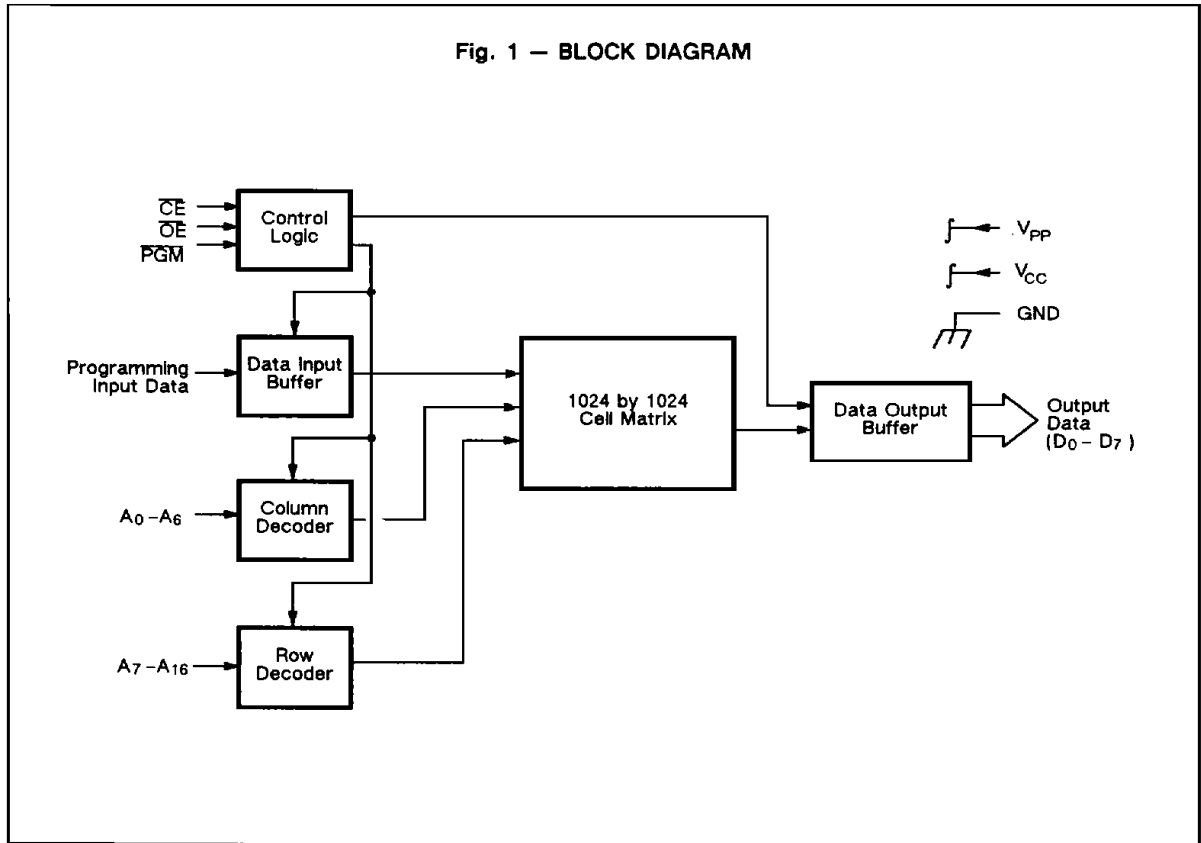

**CAPACITANCE** ( $T_A = 25\text{ }^\circ\text{C}$ ,  $f = 1\text{MHz}$ )

Parameter	Symbol	Values			Unit
		Min	Typ	Max	
Input Capacitance ( $V_{IN} = 0V$ )	$C_{IN}$			12	pF
Output Capacitance ( $V_{OUT} = 0V$ )	$C_{OUT}$			12	pF

## PIN DESCRIPTION

Symbol	Pin No. *	Function
$V_{PP}$	1	+12.5V programming voltage.
$A_0 - A_{16}$	2-12, 23 25-29	Address lines.
$O_0 - O_7$	13-15, 17-21	Three-state output data lines.
GND	16	Circuit ground.
$\overline{CE}$	22	When active Low, the device is enabled for data read.
$\overline{OE}$	24	Output enable. When $\overline{OE}$ and $\overline{CE}$ are active low and the $\overline{PGM}$ strobe is active High; all output lines ( $D_0 - D_7$ ) are enabled.
NC	30	No connection.
$\overline{PGM}$	31	When active Low, programming data from the input buffer is written into a specified address of memory.
$V_{CC}$	32	+5V power supply

\* This numbers are applied to DIP package.

## FUNCTIONS AND PIN CONNECTIONS

OPERATING MODE	$A_0 - A_8$	$A_9$	$A_{10} - A_{16}$	Data	$\overline{CE}$	$\overline{OE}$	$\overline{PGM}$	$V_{CC}$	$V_{PP}$	GND
Standby	X	X	X	HI-Z	$V_{IH}$	X	X	5V	5V	0V
Read	$A_{IN}$	$A_{IN}$	$A_{IN}$	$D_{OUT}$	$V_{IL}$	$V_{IL}$	$V_{IH}$	5V	5V	0V
Output Disable	$A_{IN}$	$A_{IN}$	$A_{IN}$	HI-Z	$V_{IL}$	$V_{IH}$ X	X $V_{IL}$	5V	5V	0V
Electronic Signature	Note 1	12V	X	CODE	$V_{IL}$	$V_{IL}$	$V_{IH}$	5V	5V	0V
Single Byte Program	$A_{IN}$	$A_{IN}$	$A_{IN}$	$D_{IN}$	$V_{IL}$	$V_{IH}$	$V_{IL}$	6V	12.5V	0V
Single Byte Verify	$A_{IN}$	$A_{IN}$	$A_{IN}$	$D_{OUT}$	$V_{IL}$	$V_{IL}$	$V_{IH}$	6V	12.5V	0V
Single Byte Program Inhibit	$A_{IN}$	$A_{IN}$	$A_{IN}$	HI-Z	$V_{IL}$	$V_{IH}$	$V_{IH}$	6V	12.5V	0V
Four Byte Data Input	Note 2	$A_{IN}$	$A_{IN}$	$D_{IN}$	$V_{IH}$	$V_{IH}$	$V_{IH}$	6V	12.5V	0V
Four Byte Program	X	$A_{IN}$	$A_{IN}$	HI-Z	$V_{IH}$	$V_{IL}$	$V_{IL}$	6V	12.5V	0V
Four Byte Verify	Note 2	$A_{IN}$	$A_{IN}$	$D_{OUT}$	$V_{IL}$	$V_{IL}$	$V_{IH}$	6V	12.5V	0V
Four Byte Program Inhibit	$A_{IN}$	$A_{IN}$	$A_{IN}$	HI-Z	$V_{IL}$	$V_{IH}$	$V_{IH}$	6V	12.5V	0V

**Legend:**

X = Don't care

**Notes:**

1.  $A_0$  is toggling address.  $A_1$  is  $V_{IL}$ .
2.  $A_0$  and  $A_1$  can be either  $V_{IL}$  or  $V_{IH}$



MBM27C1001-15  
 MBM27C1001-20  
 MBM27C1001-25

## RECOMMENDED OPERATING CONDITIONS (Referenced to GND)

Parameter	Symbol	Min	Typ	Max	Unit
Supply Voltage	$V_{CC}$	4.5	5.0	5.5	V
Supply Voltage	$V_{PP}$	$V_{CC} - 0.6$	$V_{CC}$	$V_{CC} + 0.6$	V
Input High Level	$V_{IH}$	2.0		$V_{CC} + 0.3$	V
Input Low Level	$V_{IL}$	-0.1		0.8	V
Supply Voltage	GND		0		V
Operating Temperature	$T_A$	0		70	°C

4

## DC CHARACTERISTICS

(Recommended operating conditions unless otherwise noted)

Parameter	Symbol	Conditions	Values			Unit
			Min	Typ	Max	
Input Leakage Current	$I_{LI}$	$V_{IN} = V_{CC} = 5.5V$			10	$\mu A$
Output Leakage Current	$I_{LO}$	$V_{IN} = V_{CC} = 5.5V$			10	$\mu A$
$V_{CC}$ Standby Current	$I_{SB1}$	$\overline{CE} = V_{IH}$			1	mA
$V_{CC}$ Standby Current	$I_{SB2}$	$\overline{CE} = V_{CC} \pm 0.3V$		1	100	$\mu A$
$V_{CC}$ Active Current	$I_{CC1}$	$\overline{CE} = V_{IL}, I_{OUT} = 0mA$			30	mA
$V_{CC}$ Operation Current	$I_{CC2}$	$\overline{CE} = V_{IL}; f = \text{min}, I_{OUT} = 0mA$			40	mA
					30	
$V_{PP}$ Supply Current	$I_{PP}$	$V_{PP} = V_{CC} \pm 0.6V$		1	100	$\mu A$
Output Low Level	$V_{OL}$	$I_{OL} = 2.1mA$			0.45	V
Output High Level	$V_{OH1}$	$I_{OH} = -400 \mu A$	2.4			V
Output High Level	$V_{OH2}$	$I_{OH} = -100 \mu A$	$V_{CC} - 0.7$			V

Fig. 2 — AC TEST CONDITIONS (INCLUDING PROGRAMMING)

Input pulse levels: 0.45V to 2.4V (0.3V to 2.8V programming)  
 Input Rise/Fall Times:  $\leq 20ns$   
 Input Reference Levels: 0.8V to 2.0V (0.6V to 2.4V programming)  
 Output Reference Levels: 0.8V to 2.0V  
 Output Load: 1 TTL gate and  $C_L = 100pF$

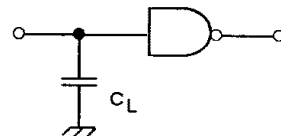

## AC CHARACTERISTICS

(Recommended operating conditions unless otherwise noted)

Parameter	Symbol	MBM27C1001-15 Values		MBM27C1001-20 Values		MBM27C1001-25 Values		Unit
		Min	Max	Min	Max	Min	Max	
Address Access Time	$t_{ACC}$		150		200		250	ns
$\overline{CE}$ to Output Delay Time	$t_{CE}$		150		200		250	ns
$\overline{OE}$ to Output Delay Time	$t_{OE}$		70	0	70	0	100	ns
$\overline{PGM}$ to Output Delay Time	$t_{PGM}$		70	0	70	0	100	ns
$\overline{CE}$ or $\overline{OE}$ to Output Float Delay (Note)	$t_{DF}$		60		60		60	ns
Address to Output Hold Time	$t_{OH}$	0		0		0		ns

4

NOTE: Output Float is defined as the point where data is no longer driven.

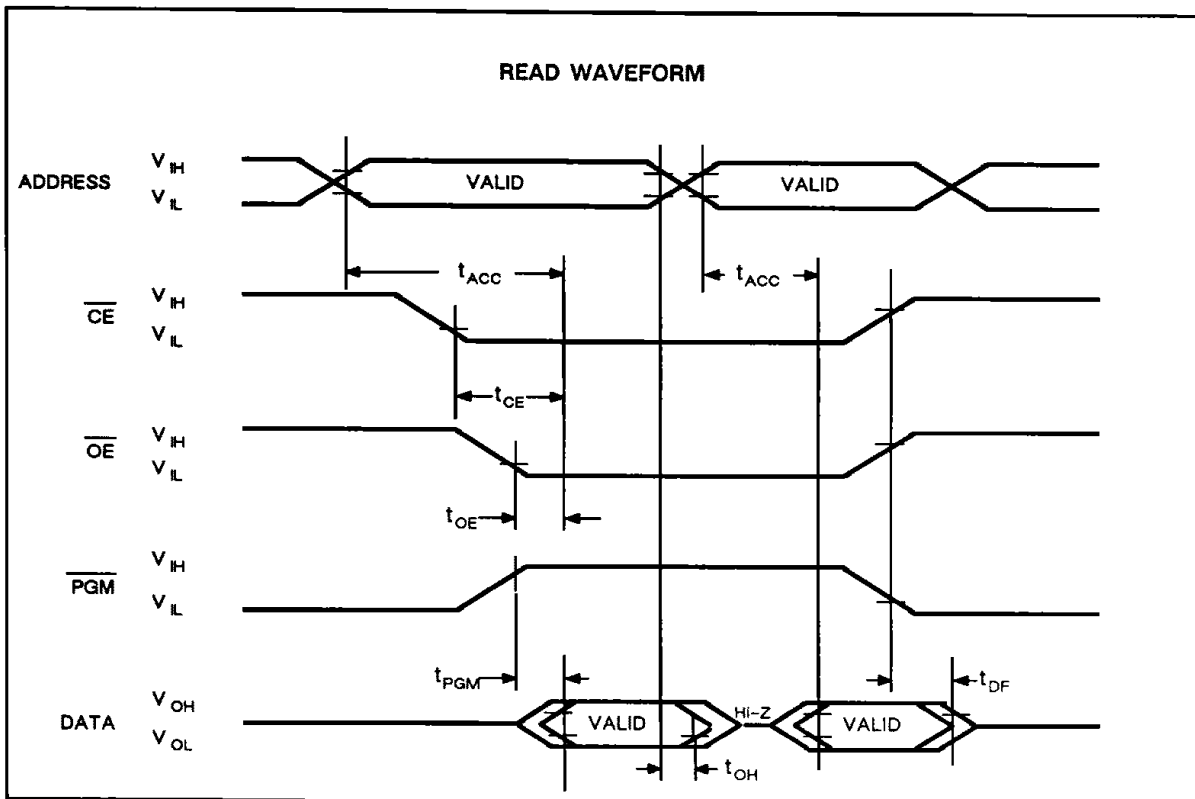



## PROGRAMMING / ERASING INFORMATION

### PROGRAMMING

**Single-Byte Programming.** When +12.5V( $\pm 0.3$ ) volts is applied to  $V_{PP}$ , +6( $\pm 0.25$ ) volts is applied to  $V_{CC}$ ,  $\overline{CE}$  and  $\overline{PGM} = V_{IH}$ , and  $\overline{OE} = V_{IH}$ , the programming mode is initiated. Next, the proper address is input and the data pattern is applied to the input buffer (Figure 1). When both address and data are stable, a 0.5-millisecond negative pulse is applied to the  $\overline{PGM}$  pin. Upon verification of written data an over pulse (three times the initial pulse width times the number of pulses used to accomplish a write) should be applied to complete the programming of one byte. Refer to the PROGRAMMING FLOWCHART that follows for step-by-step programming procedures.

**Four-Byte Programming.** When compared to single-byte programming, the four-byte programming method reduces the programming time by about 75% one quarter. Voltages applied to  $V_{PP}$  and  $V_{CC}$  are the same as those for single-byte programming; however, some logic levels differ--refer to "Four Byte Programming" in the Truth Table. In conjunction with the  $\overline{OE}$  pin, address pins A0 and A1 are used to latch four bytes of data. When both address and data are stable, a 0.5 millisecond negative pulse is applied to the  $\overline{PGM}$  pin. Upon verification of written data an over pulse (three times the initial pulse width times the number of pulses used to accomplish a write.) should be applied to complete the programming of four bytes. Refer to the PROGRAMMING FLOWCHART for step-by-step programming procedures.

#### Caution

The width of one programming pulse must not exceed 40-millisecond; thus, a continuous TTL low-level voltage should not be applied to the  $\overline{PGM}$  pin. Also, a 0.1-microfarad capacitor must be connected between  $V_{PP}$  and ground to

prevent excessive voltage transients. Neglecting either of these precautions may cause device failure.

**Electronic Signature/Programming Algorithm.** When the MBM27C1001 is shipped from the factory, all memory cells (1,048,576 bits) are set to the High state (logic 1). During the programming procedure, affected bit cells are set to the Low (logic 0) state.

The MBM27C1001 is programmed with a fast programming algorithm designed by Fujitsu called Quick Pro™. Manufacturer and device codes are electronically stored in each device; these codes can be read at the output port (D0-D7) for the purpose of matching the device with the Quick Pro™ algorithm. The Electronic Signature Code List is shown preceding the ELECTRICAL CHARACTERISTICS.

### ERASING

In order to clear all memory cells of programmed contents, the MBM27C1001 must be exposed to an ultraviolet light source. To completely erase the memory (restore all cells to a logic 1 state), a dosage of 15Wsec/cm<sup>2</sup> is required. The required exposure can be obtained by using a UV-lamp with a wavelength of 2537 Angstroms and with an intensity of 12mW/cm<sup>2</sup>. Remove all filters from the lamp and clean the transparent lid of the MBM 27C1001 with a non-abrasive cleaner. Hold the MBM 27C1001 approximately one inch from the light source for 15-to-21 minutes. (Note. The MBM 27C1001 and other similar devices can be erased by light sources with longer wavelengths; however, the erasing time is much greater. Nonetheless, exposure to fluorescents or sunlight will severely degrade and eventually erase the memory. When used in a lighted environment, it is recommended that the transparent window be covered with an opaque label.)

### ELECTRONIC SIGNATURE CODE LIST

Definition	A0	A1 TO A6	A9	A7 to A16	D0	D1	D2	D3	D4	D5	D6	D7	HEX
Manufacture	VIL	VIL	12( $\pm 0.5$ )V	Don't Care	0	0	1	0	0	0	0	0	#04
Device	VIH	VIL	12( $\pm 0.5$ )V	Don't Care	0	1	1	0	0	1	1	1	#E6

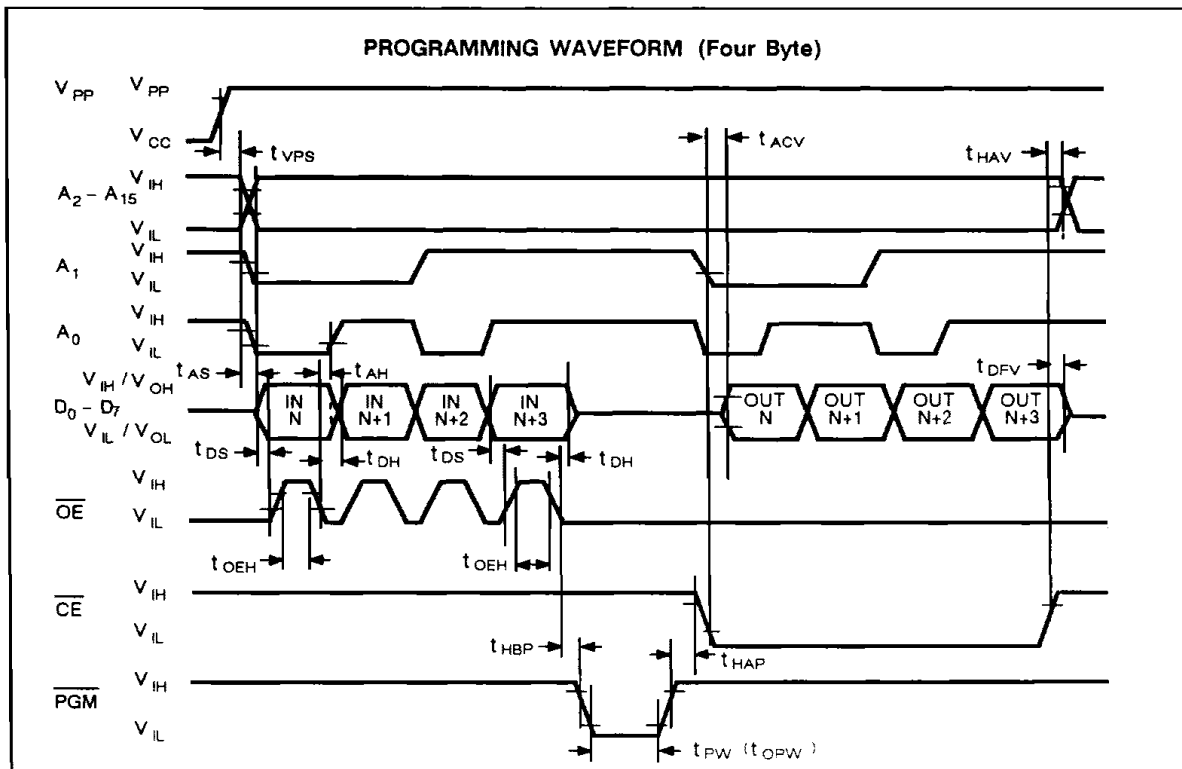
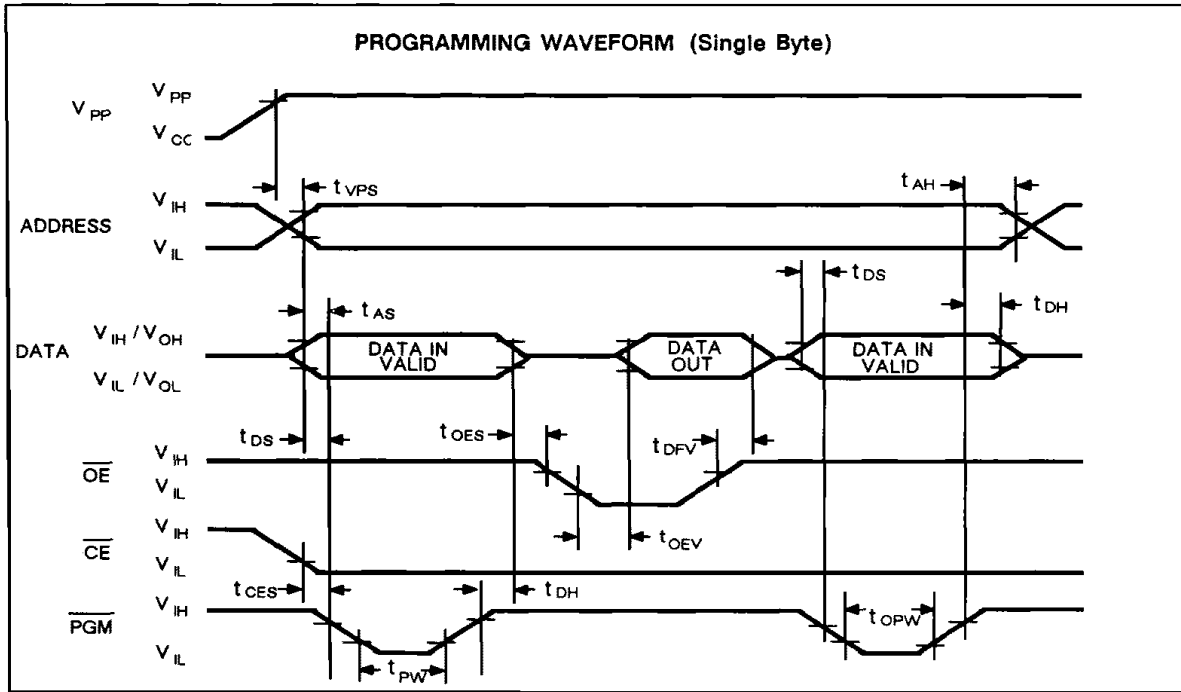

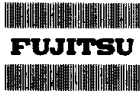

MBM27C1001-15  
 MBM27C1001-20  
 MBM27C1001-25

**DC CHARACTERISTICS (Programming Mode)**

( $T_A = 25\text{ }^\circ\text{C} \pm 5^\circ\text{C}$ ,  $V_{CC}^1 = 6\text{V} \pm 0.25\text{V}$ ,  $V_{PP}^2 = 12.5\text{V} \pm 0.3\text{V}$ )

Parameter	Symbol	Conditions	Values			Unit
			Min	Typ	Max	
Input Leakage Current	$I_{LI}$	$V_{IN} = 6.25\text{V}/0\text{V}$			10	$\mu\text{A}$
Input High Level	$V_{IH}$		2.4		$V_{CC} + 0.3$	V
Input Low Level	$V_{IL}$		-0.1		0.6	V
$V_{CC}$ Supply Current	$I_{CC}$				30	mA
$V_{PP}$ Supply Current	$I_{PP1}$	$\overline{CE} = \overline{PGM} = V_{IL}; \overline{OE} = V_{IH}$			30	mA
$V_{PP}$ Supply Current	$I_{PP2}$	$\overline{CE} = V_{IH}; \overline{OE} = \overline{PGM} = V_{IL}$			100	mA
$V_{PP}$ Supply Current	$I_{PP3}$	$\overline{PGM} = V_{IH}$			5	mA
Output Low Level	$V_{OL}$	$I_{OL} = 2.1\text{mA}$			0.45	V
Output High Level	$V_{OH}$	$I_{OH} = -400\text{ }\mu\text{A}$	2.4			V

NOTE \*1  $V_{CC}$  must be applied either coincidentally or before  $V_{PP}$  and removed either coincidentally or after  $V_{PP}$ .

\*2  $V_{PP}$  must not be greater than 13.5 volts including overshoot. Permanent device damage may occur if the device is taken out or put into socket remaining  $V_{PP} = 12.5$  volts. Also, during  $\overline{CE} = V_{IL}$ ,  $\overline{OE} = V_{IH}$ ,  $V_{PP}$  must not be switched from  $V_{CC}$  to  $V_{PP}$  volts or vice versa.

**AC CHARACTERISTICS  
 (Single Byte Programming)**

Parameter	Symbol	Values			Unit
		Min	Typ	Max	
$V_{PP}$ Setup Time	$t_{VPS}$	2			$\mu\text{S}$
Address Setup Time	$t_{AS}$	2			$\mu\text{S}$
Data Setup Time	$t_{DS}$	2			$\mu\text{S}$
$\overline{CE}$ Setup Time	$t_{CES}$	2			$\mu\text{S}$
$\overline{OE}$ Setup time	$t_{OES}$	2			$\mu\text{S}$
Address Hold Time	$t_{AH}$	2			$\mu\text{S}$
Data Hold Time	$t_{DH}$	2			$\mu\text{S}$
$\overline{OE}$ to Output Valid	$t_{OEV}$			500	ns
$\overline{OE}$ to Output Float	$t_{DFV}$			150	ns
Programming Pulse Width	$t_{PW}$	0.475	0.50	0.525	ms
Over Programming Pulse Number	N	1		25	times
Over Programming Pulse Width (Note)	$t_{OPW}$	1.4	1.5	39.4	ms

NOTE:  $t_{OPW} = 1.5 \times N\text{ms} \pm 5\%$

**AC CHARACTERISTICS**  
**(Four Byte Programming)**

Parameter	Symbol	Values			Unit
		Min	Typ	Max	
V <sub>pp</sub> Setup Time	t <sub>VPS</sub>	2			μs
Address Setup Time	t <sub>AS</sub>	2			μs
Data Setup Time	t <sub>DS</sub>	2			μs
Address Hold Time	t <sub>AH</sub>	2			μs
Data Hold Time	t <sub>DH</sub>	2			μs
$\overline{\text{OE}}$ High Hold Time	t <sub>OEH</sub>	2			μs
Hold Time Before Programming	t <sub>HBP</sub>	2			μs
Hold Time After Program	t <sub>HAP</sub>	2			μs
Address Access Time at Verify	t <sub>ACV</sub>			500	ns
$\overline{\text{CE}}$ to Output Float at Verify	t <sub>DFV</sub>			150	ns
Hold Time After Verify	t <sub>HAV</sub>	0			μs
Programming Pulse Width	t <sub>PW</sub>	0.475	0.50	0.525	ms
Over Programming Pulse Number	N	1		25	times
Over Programming Pulse Width (Note)	t <sub>OPW</sub>	1.4	1.5	39.4	ms

NOTE: t<sub>OPW</sub> = 1.5 × Nms ± 5%



MBM27C1001-15  
MBM27C1001-20  
MBM27C1001-25

## PROGRAMMING / ERASING INFORMATION (Cont'd)

PROGRAMMING FLOWCHART FOR QUICK PRO™

- Notes:  
1. 1-byte or 4-bytes  
2. Conditions:  
 $V_{CC} = 6V (\pm 0.25)$   
 $V_{PP} = 12.5 (\pm 0.3)V$   
 $t_{PW} = 0.5ms (+5\%)$   
 $t_{OPW} = 1.5 \times Nms (+5\%)$

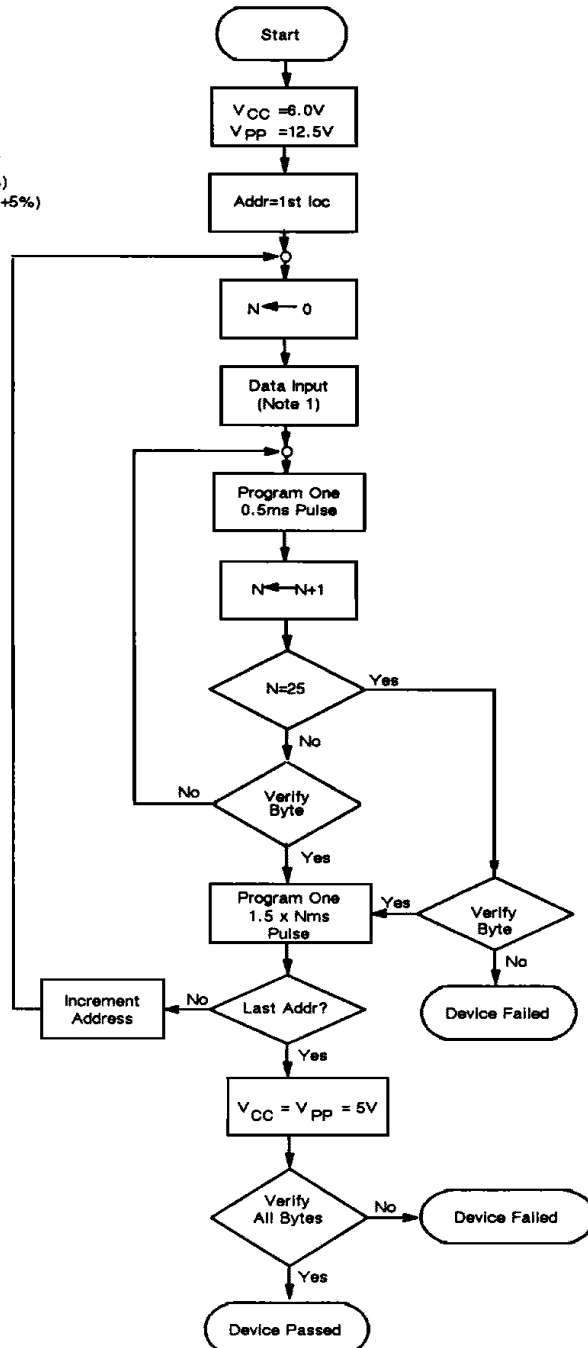

Quick Pro™ is a trademark of FUJITSU LIMITED

MBM27C1001-15  
 MBM27C1001-20  
 MBM27C1001-25



# PACKAGE DIMENSIONS

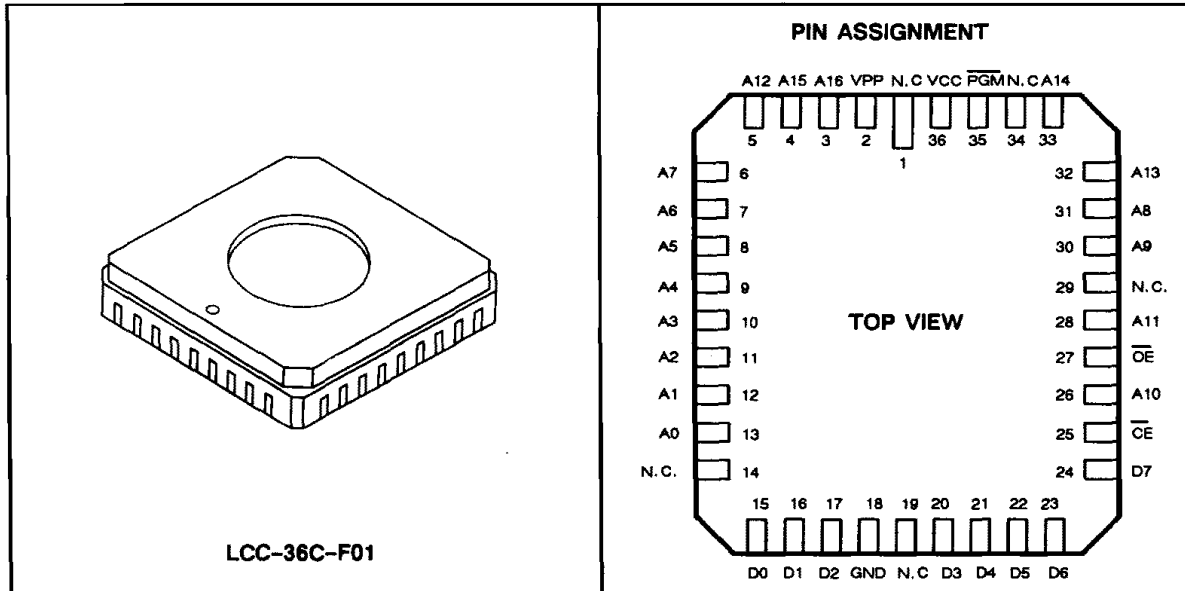

4

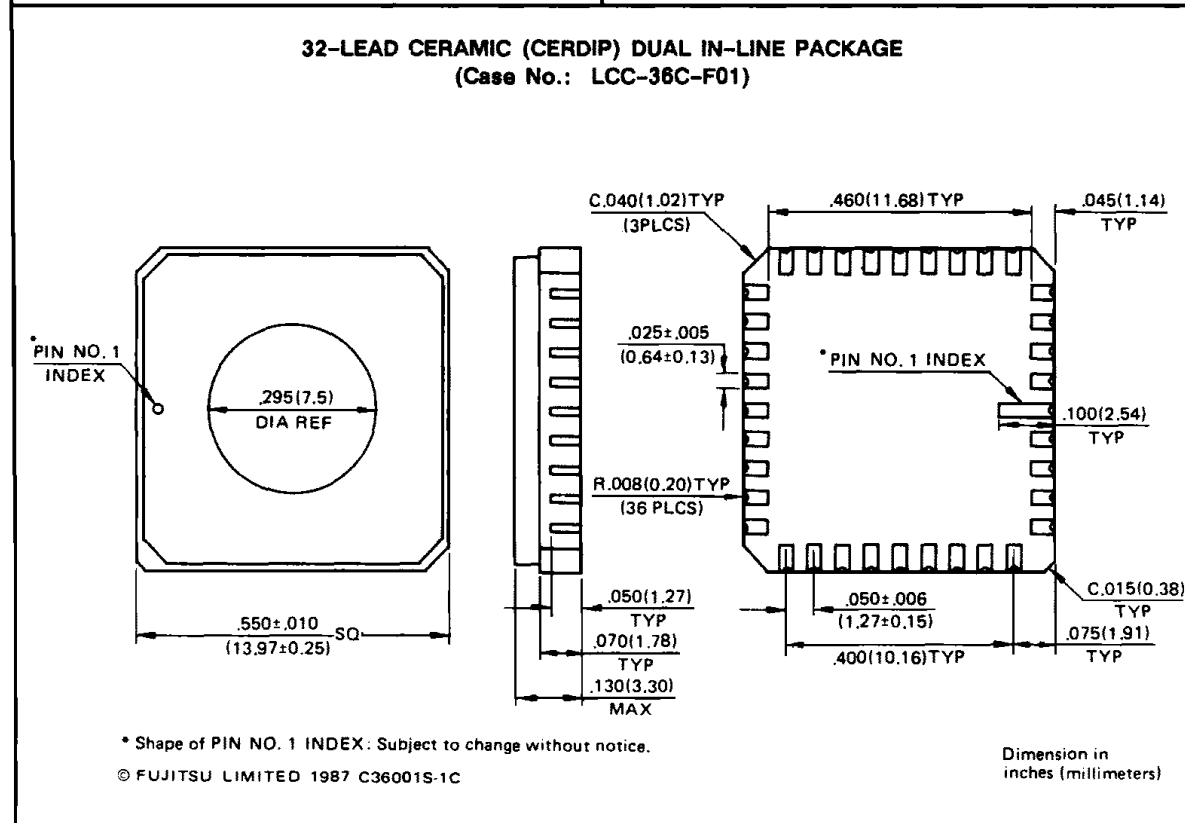



MBM27C1001-15  
MBM27C1001-20  
MBM27C1001-25

# PACKAGE DIMENSIONS

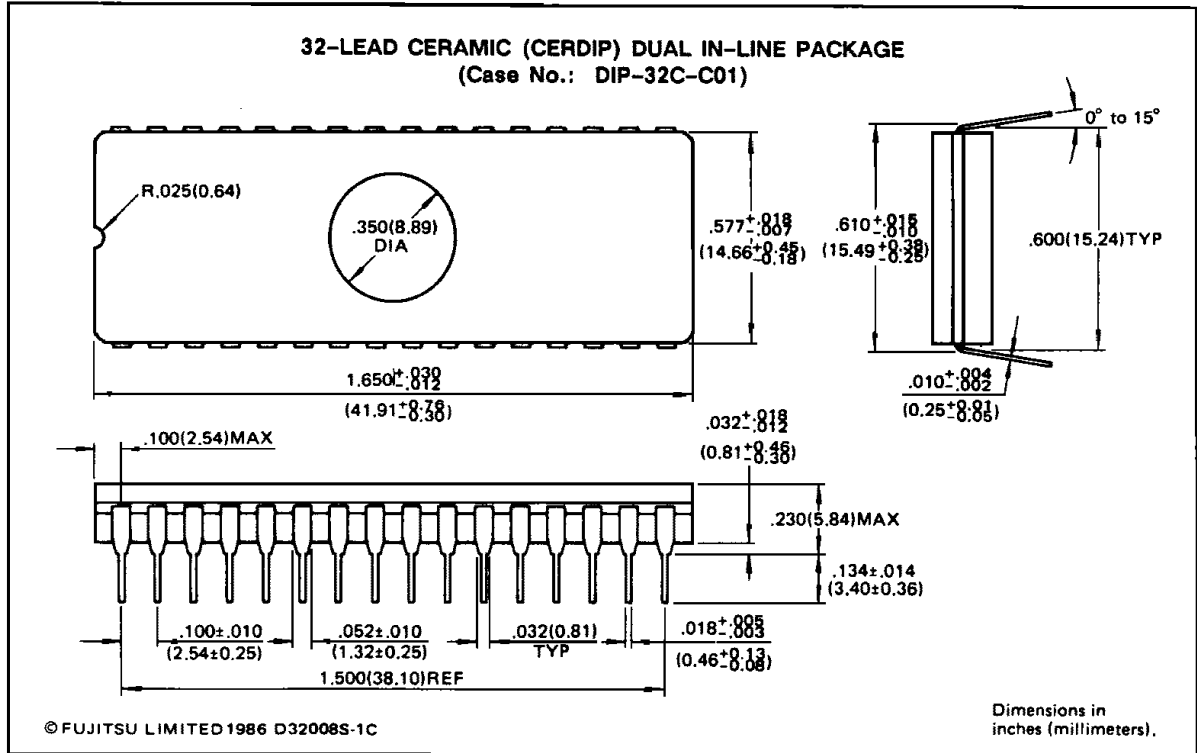

4