



Ultra-Low-Power, Open-Drain, Single/Dual-Supply Comparators

General Description

The MAX971–MAX974 and MAX981–MAX984 single/dual/quad low-voltage comparators feature the lowest power consumption available. These micropower devices draw less than 4 μ A supply current over temperature (MAX971/MAX972, MAX981/MAX982), and include an internal 1.182V \pm 1% (MAX971/MAX973/MAX974) or \pm 2% (MAX981–MAX984) voltage reference and programmable hysteresis.

Ideal for 3V or 5V single-supply applications, these devices operate from a single +2.5V to +11V supply (or \pm 1.25V to \pm 5.5V dual supplies), and each comparator's input voltage ranges from the negative supply rail to within 1.3V of the positive supply.

The single MAX971 and MAX981 and the dual MAX973 and MAX982/MAX983 provide a unique, simple method for adding hysteresis without feedback or complicated equations, simply by using the HYST pin plus two resistors.

The MAX971–MAX974 and MAX981–MAX984's open-drain outputs permit wire-ORed configurations. Thanks to an 11V output range and separate GND pin for the output transistor (MAX971/MAX974, MAX981/MAX984), these devices are ideal for level translators and bipolar to single-ended converters. For similar devices with complementary output stages, see the MAX921–MAX924 (1% reference) and the MAX931–MAX934 (2% reference).

PART	INTERNAL PRECISION REFERENCE	COMPARATORS PER PACKAGE	INTERNAL HYSTERESIS	PACKAGE
MAX971	1%	1	Yes	8-Pin DIP/SO/ μ MAX
MAX972	None	2	No	8-Pin DIP/SO/ μ MAX
MAX973	1%	2	Yes	8-Pin DIP/SO/ μ MAX
MAX974	1%	4	No	16-Pin DIP/SO
MAX981	2%	1	Yes	8-Pin DIP/SO/ μ MAX
MAX982	2%	2	Yes	8-Pin DIP/SO/ μ MAX
MAX983	2%	2	Yes	8-Pin DIP/SO/ μ MAX
MAX984	2%	4	No	16-Pin DIP/SO

Features

- ♦ μ MAX Package—Smallest 8-Pin SO (MAX9_1/MAX9_2/MAX9_3)
- ♦ Ultra-Low 4 μ A Max Quiescent Current Over Extended Temp. Range (MAX971/MAX981)
- ♦ Power Supplies: Single +2.5V to +11V Dual \pm 1.25V to \pm 5.5V
- ♦ Input Voltage Range Includes Negative Supply
- ♦ Internal 1.182V \pm 1% Bandgap Reference
- ♦ 12 μ s Propagation Delay (10mV Overdrive)
- ♦ Output Has Separate GND Pin (MAX9_1/MAX9_4)

Applications

Battery-Powered Systems Level Translators
 Threshold Detectors Oscillator Circuits
 Window Comparators

Ordering Information

PART	TEMP. RANGE	PIN-PACKAGE
MAX971CPA	0°C to +70°C	8 Plastic DIP
MAX971CSA	0°C to +70°C	8 SO
MAX971CUA	0°C to +70°C	8 μ MAX
MAX971C/D	0°C to +70°C	Dice*

Ordering Information continued at end of data sheet.

* Dice are tested at $T_A = +25^\circ\text{C}$, DC parameters only.

Typical Operating Circuit

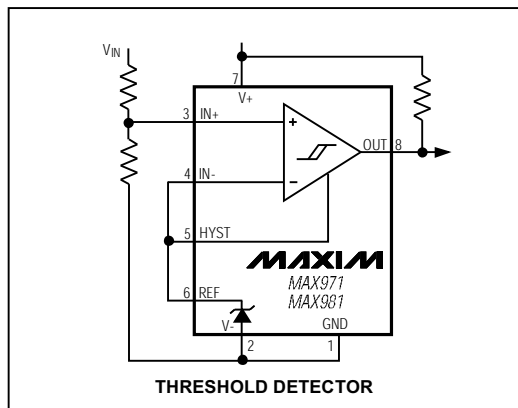

MAX971-MAX974/MAX981-MAX984



Ultra-Low-Power, Open-Drain, Single/Dual-Supply Comparators

ABSOLUTE MAXIMUM RATINGS

V+ to V-, V+ to GND, GND to V-.....-0.3V, +12V
Inputs
 Current: IN+, IN-, HYST.....20mA
 Voltage: IN+, IN-, HYST(V+ + 0.3V) to (V- - 0.3V)
Outputs
 Current: REF.....20mA
 OUT_.....50mA
 Voltage: REF(V+ + 0.3V) to (V- - 0.3V)
 OUT_ (MAX9_1/9_4)+12V to (GND - 0.3V)
 (MAX9_2/9_3)+12V to (V- - 0.3V)
 OUT_ Short-Circuit DurationContinuous
 Continuous Power Dissipation (T_A = +70°C)
 8-Pin Plastic DIP (derate 9.09mW/°C above +70°C) ...727mW

8-Pin SO (derate 5.88mW/°C above +70°C).....471mW
 8-Pin μMAX (derate 4.1mW/°C above +70°C)330mW
 8-Pin CERDIP (derate 8.00mW/°C above +70°C).....640mW
 16-Pin Plastic DIP (derate 10.53mW/°C above +70°C).....842mW
 16-Pin SO (derate 8.70mW/°C above +70°C)696mW
 16-Pin CERDIP (derate 10.00mW/°C above +70°C).....800mW
Operating Temperature Ranges
 MAX97_C_ /MAX98_C_0°C to +70°C
 MAX97_E_ /MAX98_E_-40°C to +85°C
 MAX97_MJ /MAX98_MJ_-55°C to +125°C
Storage Temperature Range-65°C to +150°C
Lead Temperature (soldering, 10sec)+300°C

Stresses beyond those listed under "Absolute Maximum Ratings" may cause permanent damage to the device. These are stress ratings only, and functional operation of the device at these or any other conditions beyond those indicated in the operational sections of the specifications is not implied. Exposure to absolute maximum rating conditions for extended periods may affect device reliability.

ELECTRICAL CHARACTERISTICS: 5V OPERATION

(V+ = 5V, V- = GND = 0V, T_A = T_{MIN} to T_{MAX}, unless otherwise noted. Typical values are at T_A = +25°C.)

PARAMETER	CONDITIONS		MIN	TYP	MAX	UNITS		
POWER REQUIREMENTS								
Supply Voltage Range	(Note 1)		2.5		11	V		
Output Voltage Range			0		11	V		
Supply Current	IN+ = IN- + 100mV	MAX9_1, HYST = REF	T _A = +25°C		2.5	3.2	μA	
			C/E temp. ranges			4		
			M temp. range			5		
		MAX972	T _A = +25°C		2.5	3.2		
			C/E temp. ranges			4		
			M temp. range			5		
		MAX982/ MAX9_3, HYST = REF	T _A = +25°C		3.1	4.5		
			C/E temp. ranges			6		
			M temp. range			7.5		
		MAX9_4	T _A = +25°C		5.5	6.5		
			C/E temp. ranges			8.5		
			M temp. range			11		
COMPARATOR								
Input Offset Voltage	V _{CM} = 2.5V				±10	mV		
Input Leakage Current (IN-, IN+)	IN+ = IN- = 2.5V		C/E temp. ranges	±0.01	±5	nA		
			M temp. range		±40			
Input Leakage Current (HYST)	MAX9_1/MAX982/MAX9_3			±0.02		nA		
Input Common-Mode Voltage Range			V-		V+ - 1.3	V		
Common-Mode Rejection Ratio	V- to (V+ - 1.3V)			0.1	1.0	mV/V		
Power-Supply Rejection Ratio	V+ = 2.5V to 11V			0.1	1.0	mV/V		
Voltage Noise	100Hz to 100kHz			20		μV _{RMS}		
Hysteresis Input Voltage Range	MAX9_1/MAX982/MAX9_3			REF - 0.05	REF	V		
Response Time (high-to-low transition)	T _A = +25°C, 100pF load, 1MΩ pull-up to V+		Overdrive = 10mV	12		μs		
			Overdrive = 100mV	4				
Response Time (low-to-high transition) (Note 2)	T _A = +25°C, 100pF load, 1MΩ pull-up to V+			300		μs		

Ultra-Low-Power, Open-Drain, Single/Dual-Supply Comparators

MAX971-MAX974/MAX981-MAX984

ELECTRICAL CHARACTERISTICS: 5V OPERATION (continued)

(V+ = 5V, V- = GND = 0V, TA = TMIN to TMAX, unless otherwise noted. Typical values are at TA = +25°C.)

PARAMETER	CONDITIONS	MIN	TYP	MAX	UNITS
Output Low Voltage	MAX9_2/MAX9_3, IOUT = 1.8mA for C/E temp. ranges, IOUT = 1.2mA for M temp. range			V- + 0.4	V
	MAX9_1/MAX9_4, IOUT = 1.8mA for C/E temp. ranges, IOUT = 1.2mA for M temp. range			GND + 0.4	
Output Leakage Current	VOU = 11V			100	nA
REFERENCE (MAX9_1/MAX982/MAX9_3/MAX9_4 ONLY)					
Reference Voltage	C temp. range	1.170	1.182	1.194	V
	E temp. range	1.158		1.206	
	M temp. range	1.147		1.217	
Source Current	TA = +25°C	15	25		µA
	C/E temp. ranges	6			
	M temp. range	4			
Sink Current	TA = +25°C	8	15		µA
	C/E temp. ranges	4			
	M temp. range	2			
Voltage Noise	100Hz to 100kHz		100		µVRMS

ELECTRICAL CHARACTERISTICS: 3V OPERATION

(V+ = 5V, V- = GND = 0V, TA = TMIN to TMAX, unless otherwise noted. Typical values are at TA = +25°C.)

PARAMETER	CONDITIONS	MIN	TYP	MAX	UNITS	
POWER REQUIREMENTS						
Supply Current	HYST = REF, IN+ = (IN- + 100mV)	MAX9_1	TA = +25°C	2.4	3.0	µA
			C/E temp. ranges		3.8	
			M temp. range		4.8	
		MAX972	TA = +25°C	2.4	3.0	
			C/E temp. ranges		3.8	
			M temp. range		4.8	
		MAX982/ MAX9_3	TA = +25°C	3.4	4.3	
			C/E temp. ranges		5.8	
			M temp. range		7.2	
		MAX9_4	TA = +25°C	5.2	6.2	
			C/E temp. ranges		8.0	
			M temp. range		10.5	
COMPARATOR						
Input Offset Voltage	VCM = 1.5V			±10	mV	
Input Leakage Current (IN-, IN+)	IN+ = IN- = 1.5V	C/E temp. ranges	±0.01	±5	nA	
		M temp. range		±40		
Input Leakage Current (HYST)	MAX9_1/MAX982/MAX9_3		±0.02		nA	
Input Common-Mode Voltage Range		V-		V+ - 1.3	V	
Common-Mode Rejection Ratio	V- to (V+ - 1.3V)		0.2	1	mV/V	
Power-Supply Rejection Ratio	V+ = 2.5V to 11V		0.1	1	mV/V	

Ultra-Low-Power, Open-Drain, Single/Dual-Supply Comparators

ELECTRICAL CHARACTERISTICS: 3V OPERATION (continued)

(V+ = 5V, V- = GND = 0V, TA = TMIN to TMAX, unless otherwise noted. Typical values are at TA = +25°C.)

PARAMETER	CONDITIONS	MIN	TYP	MAX	UNITS
Voltage Noise	100Hz to 100kHz		20		μ V _{RMS}
Hysteresis Input Voltage Range	MAX9_1/MAX982/MAX9_3	REF - 0.05		REF	V
Response Time (high-to-low transition)	TA = +25°C, 100pF load, 1M Ω pull-up to V+	Overdrive = 10mV	12		μ s
		Overdrive = 100mV	4		
Response Time (low-to-high transition) (Note 2)	TA = +25°C, 100pF load, 1M Ω pull-up to V+		300		μ s
Output Low Voltage	MAX9_2/MAX9_3, IO _{UT} = 0.8mA for C/E temp. ranges, IO _{UT} = 0.6mA for M temp. range			V- + 0.4	V
	MAX9_1/MAX9_4, IO _{UT} = 0.8mA for C/E temp. ranges, IO _{UT} = 0.6mA for M temp. range			GND + 0.4	
Output Leakage Current	VO _{UT} = 11V			100	nA
REFERENCE					
Reference Voltage	C temp. range	1.170	1.182	1.194	V
	E temp. range	1.158		1.206	
	M temp. range	1.147		1.217	
Source Current	TA = +25°C	15	25		μ A
	C/E temp. ranges	6			
	M temp. range	4			
Sink Current	TA = +25°C	8	15		μ A
	C/E temp. ranges	4			
	M temp. range	2			
Voltage Noise	100Hz to 100kHz		100		μ V _{RMS}

Note 1: MAX974/MAX984 comparators work below 2.5V; see *Low-Voltage Operation* section for more details.

Note 2: Low-to-high response time is the result of the 1M Ω pull-up and the 100pF capacitive load, based on three time constants. A faster response time is achieved with a smaller RC.

Typical Operating Characteristics

(V+ = 5V, V- = GND, TA = +25°C, unless otherwise noted.)

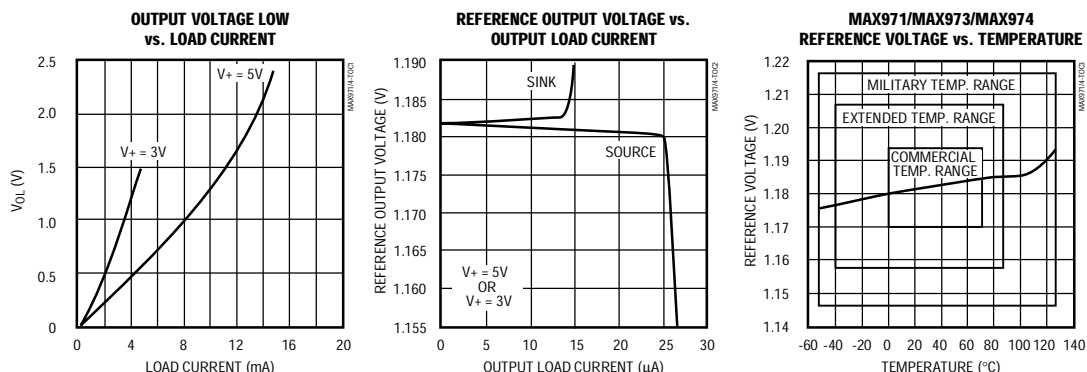

Ultra-Low-Power, Open-Drain, Single/Dual-Supply Comparators

Typical Operating Characteristics (continued)

($V_+ = 5V$, $V_- = GND$, $T_A = +25^\circ C$, unless otherwise noted.)

MAX971-MAX974/MAX981-MAX984

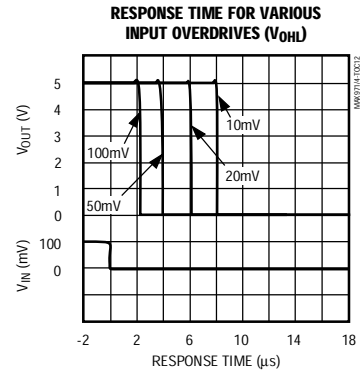
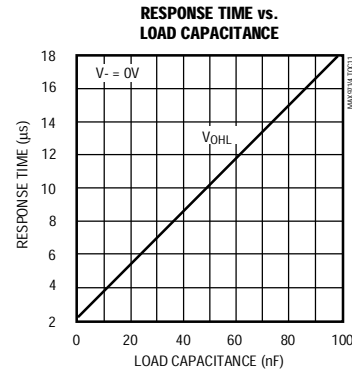
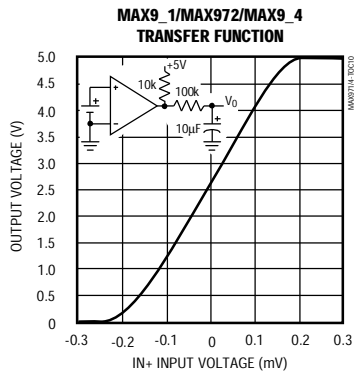
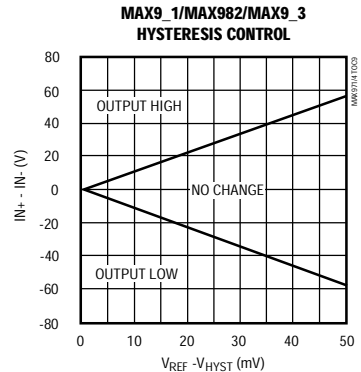
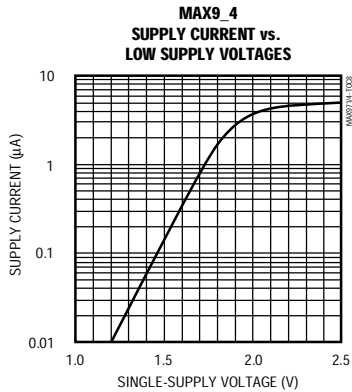
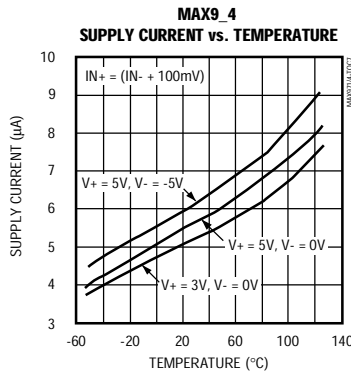
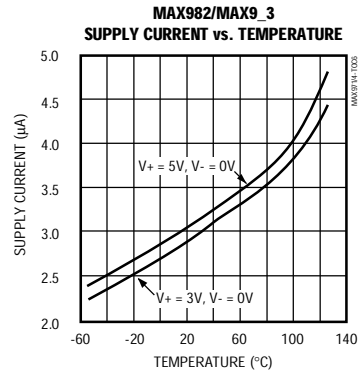
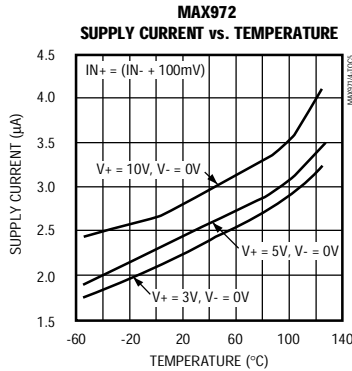
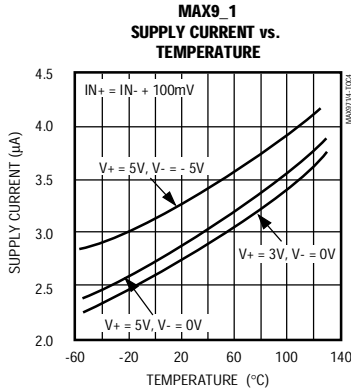

Ultra-Low-Power, Open-Drain, Single/Dual-Supply Comparators

Typical Operating Characteristics (continued)

(V+ = 5V, V- = GND, T_A = +25°C, unless otherwise noted.)

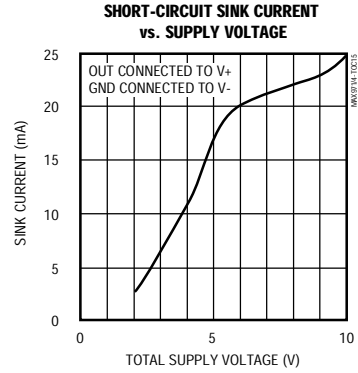
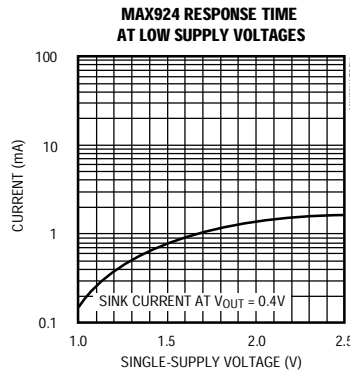
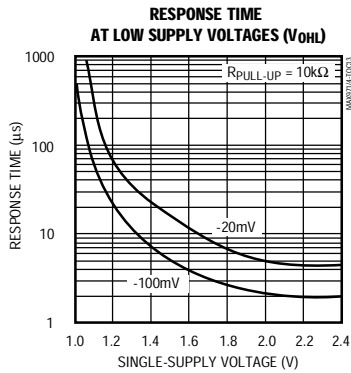

Pin Descriptions

PIN				NAME	FUNCTION
MAX971 MAX981	MAX972	MAX982	MAX973 MAX983		
1	—	—	—	GND	Ground. Connect to V- for single-supply operation. Output transistor pulls to GND.
—	1	1	1	OUTA	Comparator A Open-Drain Output. Sinks current to V-.
2	2	2	2	V-	Negative Supply. Connect to ground for single-supply operation (MAX9_1).
3	—	—	—	IN+	Noninverting Comparator Input
—	3	3	3	INA+	Noninverting Input of Comparator A
4	—	—	—	IN-	Inverting Comparator Input
—	4	—	—	INA-	Inverting Input of Comparator A
—	5	—	4	INB-	Inverting Input of Comparator B
—	6	4	—	INB+	Noninverting Input of Comparator B
5	—	5	5	HYST	Hysteresis Input. Connect to REF if not used. Input voltage range is from V _{REF} to V _{REF} - 50mV.
6	—	6	6	REF	Reference Output. 1.182V with respect to V-.
7	7	7	7	V+	Positive Supply
8	—	—	—	OUT	Comparator Output. Sinks current to GND.
—	8	8	8	OUTB	Comparator B Open-Drain Output. Sinks current to V-.

Ultra-Low-Power, Open-Drain, Single/Dual-Supply Comparators

Pin Descriptions (continued)

PIN	NAME	FUNCTION
MAX974 MAX984		
1	OUTB	Comparator B Open-Drain Output. Sinks current to GND.
2	OUTA	Comparator A Open-Drain Output. Sinks current to GND.
3	V+	Positive Supply
4	INA-	Inverting Input of Comparator A
5	INA+	Noninverting Input of Comparator A
6	INB-	Inverting Input of Comparator B
7	INB+	Noninverting Input of Comparator B
8	REF	Reference Output. 1.182V with respect to V-.
9	V-	Negative Supply. Connect to ground for single-supply operation.
10	INC-	Inverting Input of Comparator C
11	INC+	Noninverting Input of Comparator C
12	IND-	Inverting Input of Comparator D
13	IND+	Noninverting Input of Comparator D
14	GND	Ground. Connect to V- for single-supply operation.
15	OUTD	Comparator D Open-Drain Output. Sinks current to GND.
16	OUTC	Comparator C Open-Drain Output. Sinks current to GND.

MAX971-MAX974/MAX981-MAX984

Ultra-Low-Power, Open-Drain, Single/Dual-Supply Comparators

Detailed Description

The MAX971-MAX974 and MAX981-MAX984 comprise various combinations of a micropower 1.182V reference and micropower comparators. The *Typical Operating Circuit* shows the MAX971/MAX981 configuration, and Figures 1a-1d show the MAX9_2-MAX9_4 configurations.

Internal hysteresis in the MAX9_1, MAX982, and MAX9_3 provides the easiest method for implementing hysteresis. It also produces faster hysteresis action and consumes much less current than circuits using external positive feedback.

Power-Supply and Input Signal Ranges

This family of devices operates from a single +2.5V to +11V power supply. The MAX9_1 and MAX9_4 have a separate ground for the output driver, allowing operation with dual supplies ranging from $\pm 1.25V$ to $\pm 5.5V$. Connect V- to GND when operating the MAX9_1 or MAX9_4 from a single supply. The maximum total supply voltage in this case is still 11V.

For proper comparator operation, the input signal can range from the negative supply (V-) to within one volt of the positive supply ($V+ - 1V$). The guaranteed common-mode input voltage range extends from V- to ($V+ - 1.3V$). The inputs can be taken above and below the supply rails by up to 300mV without damage.

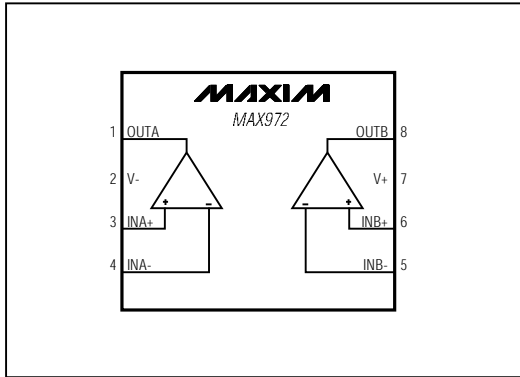

Figure 1a. MAX972 Functional Diagram

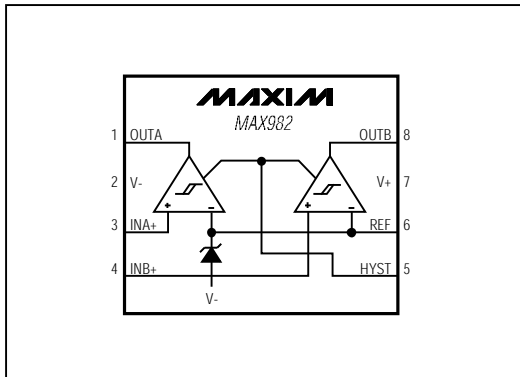

Figure 1b. MAX982 Functional Diagram

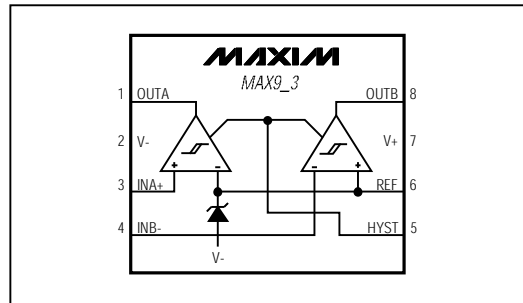

Figure 1c. MAX973/MAX983 Functional Diagram (Window Comparator)

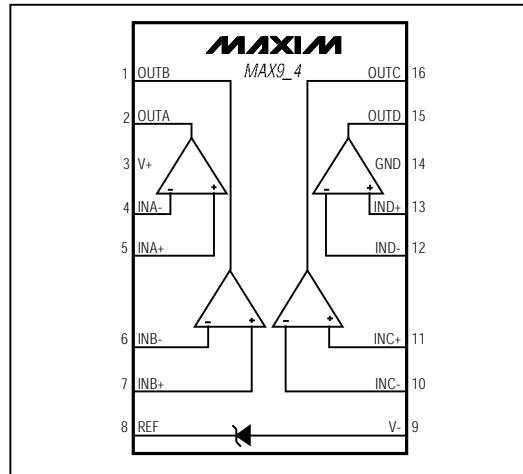

Figure 1d. MAX974/MAX984 Functional Diagram

Ultra-Low-Power, Open-Drain, Single/Dual-Supply Comparators

MAX971-MAX974/MAX981-MAX984

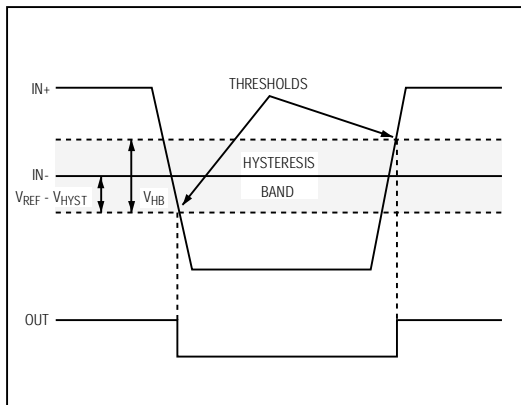

Figure 2. Threshold Hysteresis Band

Low-Voltage Operation: $V^+ = 1V$ (MAX9_4 Only)

The guaranteed minimum operating voltage is 2.5V (or $\pm 1.25V$). As the total supply voltage falls below 2.5V, performance degrades and the supply current falls. The reference will not function below about 2.2V, although the comparators will continue to operate with a total supply voltage as low as 1V. While the MAX9_4 has comparators that may be used at supply voltages below 2V, the MAX9_1/MAX9_2/MAX9_3 may not be used with supply voltages below 2.5V.

At low supply voltages, the comparators' output sink capability is reduced and the propagation delay increases (see *Typical Operating Characteristics*). The useful input voltage range extends from the negative supply to a little under 1V below the positive supply, which is slightly closer to the positive rail than when the device operates from higher supply voltages. Test your prototype over the full temperature and supply-voltage range if you anticipate operation below 2.5V.

Comparator Output

With 100mV of overdrive, propagation delay is typically 3 μ s. The *Typical Operating Characteristics* show the propagation delay for various overdrive levels. The open-drain outputs are intended for wire-ORed and level-shifting applications. The maximum output voltage is 11V above V^- , and may be applied even when no supply voltage is present ($V^+ = V^-$).

The MAX9_1 and MAX9_4 outputs sink current to GND, making these devices ideal for bipolar to single-ended conversion and level-shifting applications.

The negative supply does not affect the output sink current. The positive supply provides gate drive for the output N-channel MOSFET and heavily influences the output current capability, especially at low supply voltages (see *Typical Operating Characteristics* section).

The MAX9_2 and MAX9_3 have no GND pin, and their outputs sink current to V^- .

Voltage Reference

The internal bandgap voltage reference has an output of 1.182V above V^- . Note that the REF voltage is referenced to V^- , not to GND. Its accuracy is $\pm 1\%$ (MAX971/MAX973/MAX974) or $\pm 2\%$ (MAX981-MAX984) in the 0°C to +70°C range. The REF output is typically capable of sourcing 25 μ A and sinking 15 μ A. Do not bypass the REF output.

Noise Considerations

Although the comparators have a very high gain, useful gain is limited by noise. This is shown in the Transfer Function graph (see *Typical Operating Characteristics*). As the input voltage approaches the comparator's offset, the output begins to bounce back and forth; this peaks when $V_{IN} = V_{OS}$. (The lowpass filter shown on the graph averages out the bouncing, making the transfer function easy to observe.) Consequently, the comparator has an effective wideband peak-to-peak noise of around 300 μ V. The voltage reference has peak-to-peak noise approaching 1mV. Thus, when a comparator is used with the reference, the combined peak-to-peak noise is about 1mV. This, of course, is much higher than the RMS noise of the individual components. Take care in your layout to avoid capacitive coupling from any output to the reference pin. Crosstalk can significantly increase the actual noise of the reference.

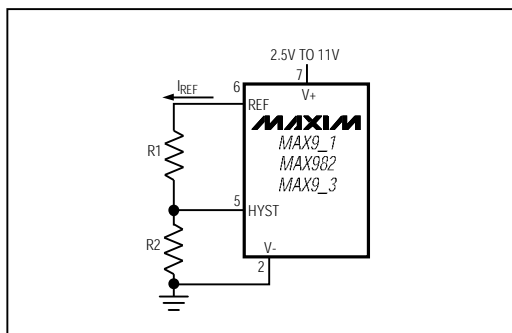

Figure 3. Programming the HYST Pin

Ultra-Low-Power, Open-Drain, Single/Dual-Supply Comparators

Applications Information

Hysteresis

Hysteresis increases the comparators' noise margin by increasing the upper threshold and decreasing the lower threshold (Figure 2).

Hysteresis (MAX9_1/MAX982/MAX9_3)

To add hysteresis to the MAX9_1, MAX982, or MAX9_3, connect resistor R1 between REF and HYST, and connect resistor R2 between HYST and V- (Figure 3). If no hysteresis is required, connect HYST to REF. When hysteresis is added, the upper threshold increases by the same amount that the lower threshold decreases. The hysteresis band (the difference between the upper and lower thresholds, V_{HB}) is approximately equal to twice the voltage between REF and HYST. The HYST input can be adjusted to a maximum voltage of REF and to a minimum voltage of (REF - 50mV). The maximum difference between REF and HYST (50mV) will therefore produce a 100mV max hysteresis band. Use the following equations to determine R1 and R2:

$$R1 = \frac{V_{HB}}{(2 \times I_{REF})}$$

$$R2 = \frac{\left(1.182 - \frac{V_{HB}}{2}\right)}{I_{REF}}$$

where I_{REF} (the current sourced by the reference) should not exceed the REF source capability, and should be significantly larger than the HYST input current. I_{REF} values between 0.1 μ A and 4 μ A are usually appropriate. If 2.4M Ω is chosen for R2 (I_{REF} = 0.5 μ A), the equation for R1 and V_{HB} can be approximated as:

$$R1 (k\Omega) = V_{HB} (mV)$$

When hysteresis is obtained in this manner for the MAX982/MAX9_3, the same hysteresis applies to both comparators.

Hysteresis (MAX972/MAX9_4)

Hysteresis can be implemented with any comparator using positive feedback, as shown in Figure 4. This approach generally draws more current than circuits using the HYST pin on the MAX9_1/MAX982/MAX9_3, and the high feedback impedance slows hysteresis. In addition, because the output does not source current, any increase in the upper threshold is dependent on the load or pull-up resistor on the output.

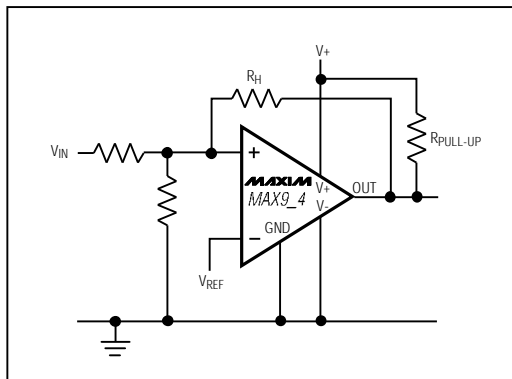

Figure 4. External Hysteresis

Board Layout and Bypassing

Power-supply bypass capacitors are not needed if the supply impedance is low, but 100nF bypass capacitors should be used when the supply impedance is high or when the supply leads are long. Minimize signal lead lengths to reduce stray capacitance between the input and output that might cause instability. Do not bypass the reference output.

Window Detector

The MAX9_3 is ideal for making window detectors (undervoltage/overvoltage detectors). The schematic is shown in Figure 5, with component values selected for a 4.5V undervoltage threshold and a 5.5V overvoltage threshold. Choose different thresholds by changing the values of R1, R2, and R3. To prevent chatter at the output when the supply voltage is close to a threshold, hysteresis has been added using R4 and R5. Taken alone, OUTA would provide an active-low undervoltage indication, and OUTB would give an active-low overvoltage indication. Wired-ORing the two outputs provides an active-high, power-good signal.

The design procedure is as follows:

- 1) Choose the required hysteresis level and calculate values for R4 and R5 according to the formulas in the *Hysteresis (MAX9_1/MAX982/MAX9_3)* section. In this example, ± 5 mV of hysteresis has been added at the comparator input ($V_H = V_{HB} / 2$). This means that the hysteresis apparent at V_{IN} will be larger because of the input resistor divider.

Ultra-Low-Power, Open-Drain, Single/Dual-Supply Comparators

2) Select R1. The leakage current into INB- is normally under 1nA, so the current through R1 should exceed 100nA for the thresholds to be accurate. R1 values up to about 10MΩ can be used, but values in the 100kΩ to 1MΩ range are usually easier to deal with. In this example, choose R1 = 294kΩ.

3) Calculate R2 + R3. The overvoltage threshold should be 5.5V when VIN is rising. The design equation is as follows:

$$\begin{aligned} R2 + R3 &= R1 \times \left(\frac{V_{OTH}}{V_{REF} + V_H} - 1 \right) \\ &= 294k \times \left(\frac{5.5}{(1.182 + 0.005)} - 1 \right) \\ &= 1.068M\Omega \end{aligned}$$

4) Calculate R2. The undervoltage threshold should be 4.5V when VIN is falling. The design equation is as follows:

$$\begin{aligned} R2 &= (R1 + R2 + R3) \times \frac{(V_{REF} - V_H)}{V_{UTH}} - R1 \\ &= (294k + 1.068M) \times \frac{(1.182 - 0.005)}{4.5} - 294k \\ &= 62.2k\Omega \end{aligned}$$

Choose R2 = 61.9kΩ (1% standard value).

5) Calculate R3:

$$\begin{aligned} R3 &= (R2 + R3) - R2 \\ &= 1.068M - 61.9k \\ &= 1.006M\Omega \end{aligned}$$

Choose R3 = 1MΩ (1% standard value)

6) Verify the resistor values. The equations are as follows, evaluated for the above example:

Overtolerance Threshold:

$$\begin{aligned} V_{OTH} &= (V_{REF} + V_H) \times \frac{(R1 + R2 + R3)}{R1} \\ &= 5.474V \end{aligned}$$

Undervoltage Threshold:

$$\begin{aligned} V_{UTH} &= (V_{REF} - V_H) \times \frac{(R1 + R2 + R3)}{(R1 + R2)} \\ &= 4.484V \end{aligned}$$

where the hysteresis voltage $V_H = V_{REF} \times \frac{R5}{R4}$.

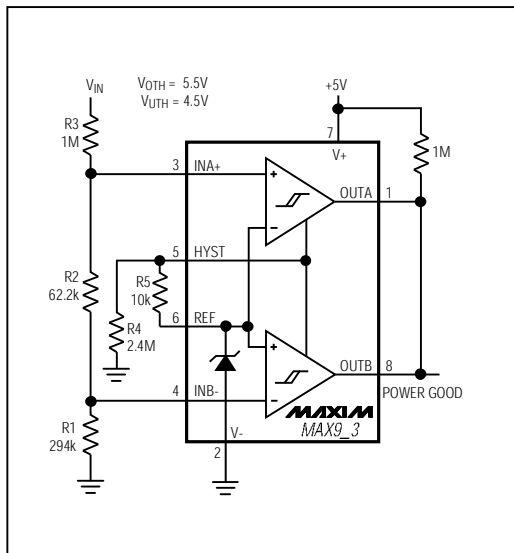

Figure 5. Window Detector

Battery Switchover Circuit

The switchover from line-powered DC to a backup battery is often accomplished with diodes. But this simple method is sometimes unacceptable, due to the voltage drop and associated power loss across the diode in series with the battery. Figure 6's circuit replaces the diode with a P-channel MOSFET controlled by one of the MAX9_3 comparator outputs.

When the DC wall adapter drops below 4V (determined by R1 and R2), OUTA goes low, turning on Q1. Comparator B is used to measure the battery voltage, and gives a "low-battery" indication when the battery drops below 3.6V.

Level Shifter

Figure 7 shows a circuit to shift from bipolar ±5V inputs to single-ended +5V outputs. The 10kΩ resistors protect the comparator inputs, and do not materially affect the circuit's operation.

MAX971-MAX974/MAX981-MAX984

Ultra-Low-Power, Open-Drain, Single/Dual-Supply Comparators

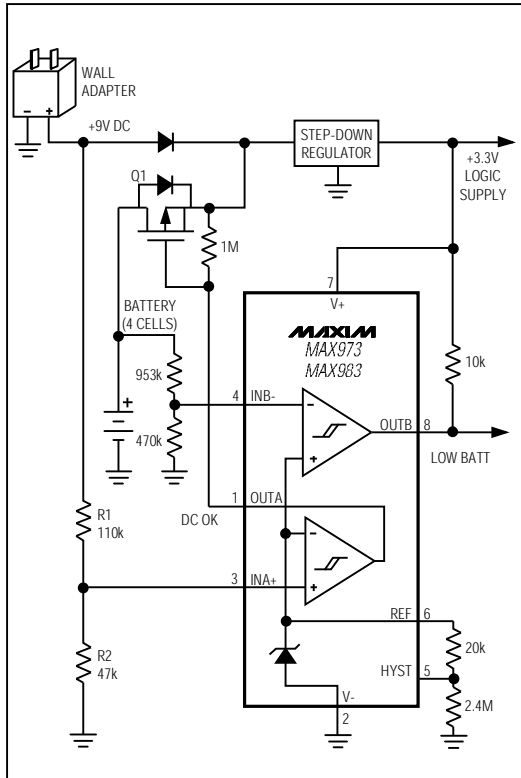

Figure 6. Battery Switchover Circuit

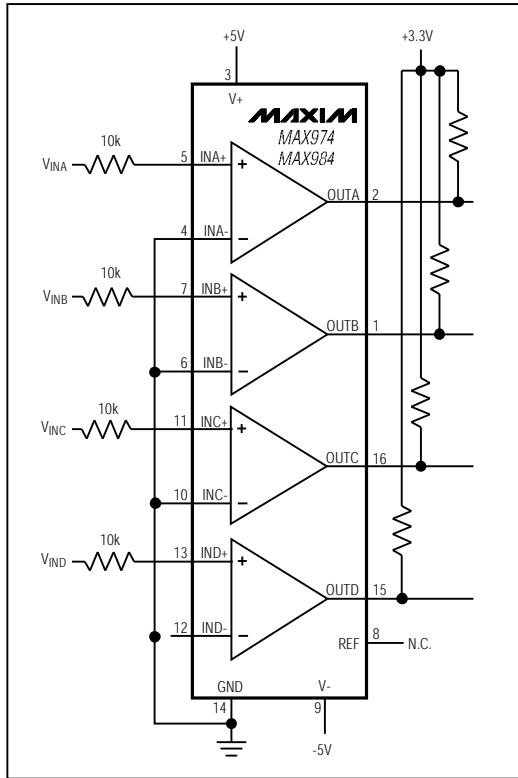
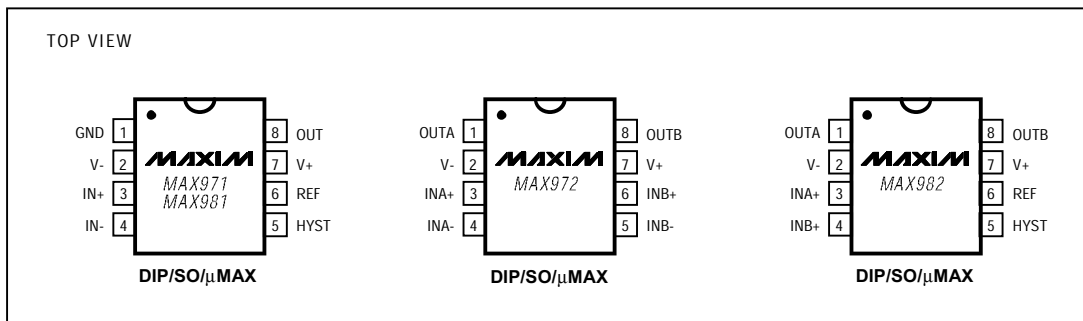

Figure 7. Level Shifter: $\pm 5V$ Input to Single-Ended +3.3V Output

Pin Configurations



Ultra-Low-Power, Open-Drain, Single/Dual-Supply Comparators

Pin Configurations (continued)

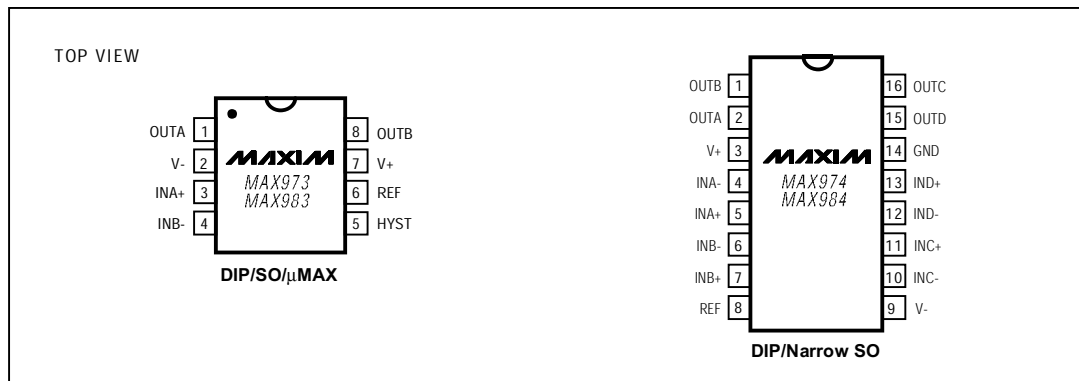

Ordering Information (continued)

PART	TEMP. RANGE	PIN-PACKAGE
MAX971EPA	-40°C to +85°C	8 Plastic DIP
MAX971ESA	-40°C to +85°C	8 SO
MAX971MJA	-55°C to +125°C	8 CERDIP**
MAX972CPA	0°C to +70°C	8 Plastic DIP
MAX972CSA	0°C to +70°C	8 SO
MAX972CUA	0°C to +70°C	8 μ MAX
MAX972C/D	0°C to +70°C	Dice*
MAX972EPA	-40°C to +85°C	8 Plastic DIP
MAX972ESA	-40°C to +85°C	8 SO
MAX972MJA	-55°C to +125°C	8 CERDIP**
MAX973CPA	0°C to +70°C	8 Plastic DIP
MAX973CSA	0°C to +70°C	8 SO
MAX973CUA	0°C to +70°C	8 μ MAX
MAX973C/D	0°C to +70°C	Dice*
MAX973EPA	-40°C to +85°C	8 Plastic DIP
MAX973ESA	-40°C to +85°C	8 SO
MAX973MJA	-55°C to +125°C	8 CERDIP**
MAX974CPE	0°C to +70°C	16 Plastic DIP
MAX974CSE	0°C to +70°C	16 Narrow SO
MAX974C/D	0°C to +70°C	Dice*
MAX974EPE	-40°C to +85°C	16 Plastic DIP
MAX974ESE	-40°C to +85°C	16 Narrow SO
MAX974MJE	-55°C to +125°C	16 CERDIP**

PART	TEMP. RANGE	PIN-PACKAGE
MAX981CPA	0°C to +70°C	8 Plastic DIP
MAX981CSA	0°C to +70°C	8 SO
MAX981CUA	0°C to +70°C	8 μ MAX
MAX981EPA	-40°C to +85°C	8 Plastic DIP
MAX981ESA	-40°C to +85°C	8 SO
MAX982CPA	0°C to +70°C	8 Plastic DIP
MAX982CSA	0°C to +70°C	8 SO
MAX982CUA	0°C to +70°C	8 μ MAX
MAX982EPA	-40°C to +85°C	8 Plastic DIP
MAX982ESA	-40°C to +85°C	8 SO
MAX983CPA	0°C to +70°C	8 Plastic DIP
MAX983CSA	0°C to +70°C	8 SO
MAX983CUA	0°C to +70°C	8 μ MAX
MAX983EPA	-40°C to +85°C	8 Plastic DIP
MAX983ESA	-40°C to +85°C	8 SO
MAX984CPE	0°C to +70°C	16 Plastic DIP
MAX984CSE	0°C to +70°C	16 Narrow SO
MAX984EPE	-40°C to +85°C	16 Plastic DIP
MAX984ESE	-40°C to +85°C	16 Narrow SO

* Dice are tested at $T_A = +25^\circ\text{C}$, DC parameters only.

** Contact factory for availability and processing to MIL-STD-883.

MAX971-MAX974/MAX981-MAX984

Ultra-Low-Power, Open-Drain, Single/Dual-Supply Comparators

Chip Information

MAX971/MAX972/MAX973

TRANSISTOR COUNT: 164
SUBSTRATE CONNECTED TO V+

MAX974

TRANSISTOR COUNT: 267
SUBSTRATE CONNECTED TO V+

MAX971-MAX974/MAX981-MAX984

Ultra-Low-Power, Open-Drain, Single/Dual-Supply Comparators

Package Information

MAX971-MAX974/MAX981-MAX984

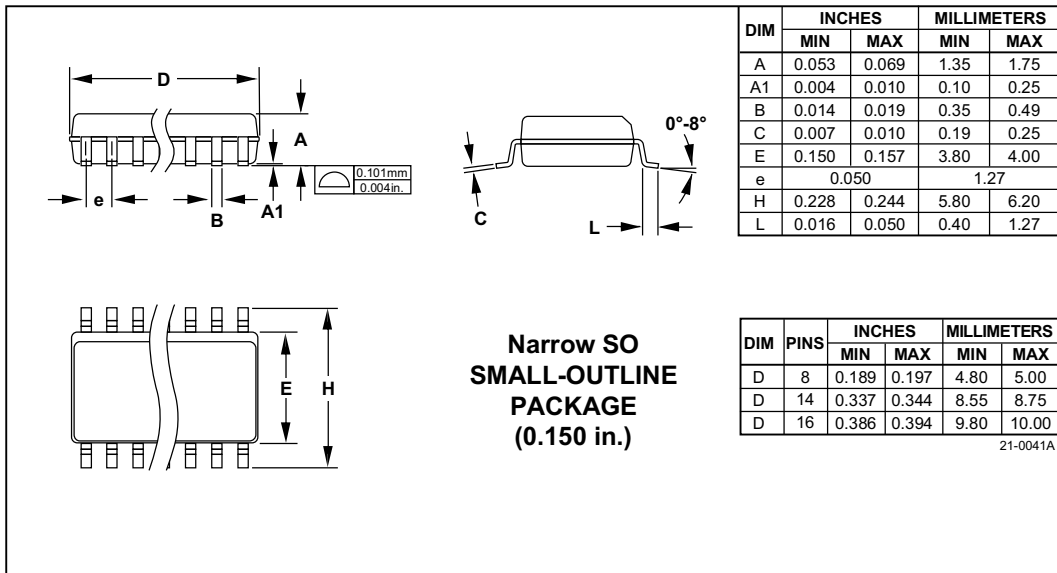
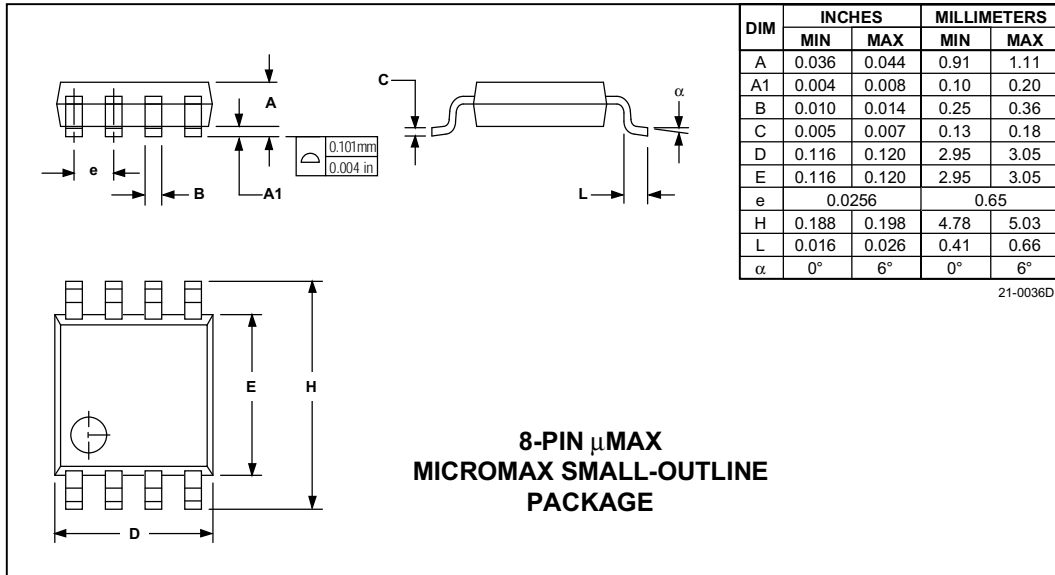

Ultra-Low-Power, Open-Drain, Single/Dual-Supply Comparators

Package Information (continued)

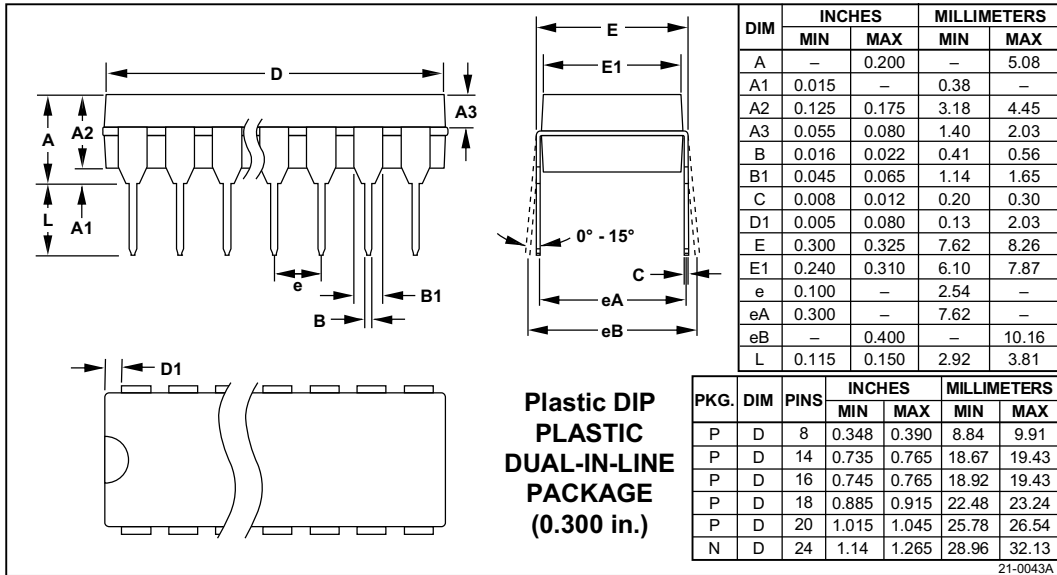

Maxim cannot assume responsibility for use of any circuitry other than circuitry entirely embodied in a Maxim product. No circuit patent licenses are implied. Maxim reserves the right to change the circuitry and specifications without notice at any time.

16 **Maxim Integrated Products, 120 San Gabriel Drive, Sunnyvale, CA 94086 (408) 737-7600**