



Microprocessor Supervisory Circuits

General Description

The MAX690A/MAX692A/MAX802L/MAX802M/MAX805L reduce the complexity and number of components required for power-supply monitoring and battery-control functions in microprocessor (μ P) systems. They significantly improve system reliability and accuracy compared to separate ICs or discrete components.

These parts provide four functions:

- 1) A reset output during power-up, power-down, and brownout conditions.
- 2) Battery-backup switching for CMOS RAM, CMOS μ P, or other low-power logic.
- 3) A reset pulse if the optional watchdog timer has not been toggled within 1.6sec.
- 4) A 1.25V threshold detector for power-fail warning or low-battery detection, or to monitor a power supply other than +5V.

The parts differ in their reset-voltage threshold levels and reset outputs. The MAX690A/MAX802L/MAX805L generate a reset pulse when the supply voltage drops below 4.65V, and the MAX692A/MAX802M generate a reset below 4.40V. The MAX802L/MAX802M guarantee power-fail accuracies to $\pm 2\%$. The MAX805L is the same as the MAX690A except that RESET is provided instead of RESET.

All parts are available in 8-pin DIP and SO packages. The MAX690A/MAX802L are pin compatible with the MAX690 and MAX694. The MAX692A/MAX802M are pin compatible with the MAX692.

Applications

Battery-Powered Computers and Controllers
Intelligent Instruments
Automotive Systems
Critical μ P Power Monitoring

Typical Operating Circuit

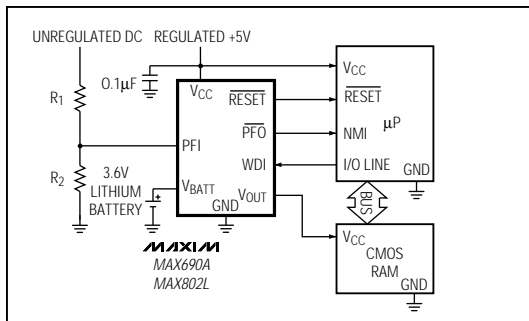

Features

- ♦ **Precision Supply-Voltage Monitor:**
4.65V for MAX690A/MAX802L/MAX805L
4.40V for MAX692A/MAX802M
- ♦ **Reset Time Delay – 200ms**
- ♦ **Watchdog Timer – 1.6sec Timeout**
- ♦ **Battery-Backup Power Switching**
- ♦ **200 μ A Quiescent Supply Current**
- ♦ **50nA Quiescent Supply Current in Battery-Backup Mode**
- ♦ **Voltage Monitor for Power-Fail or Low-Battery Warning**
- ♦ **Power-Fail Accuracy Guaranteed to $\pm 2\%$ (MAX802L/M)**
- ♦ **Guaranteed RESET Assertion to $V_{CC} = 1V$**
- ♦ **8-Pin SO and DIP Packages**

Ordering Information

PART	TEMP. RANGE	PIN-PACKAGE
MAX690ACPA	0°C to +70°C	8 Plastic DIP
MAX690ACSA	0°C to +70°C	8 SO
MAX690AC/D	0°C to +70°C	Dice*
MAX690AEPA	-40°C to +85°C	8 Plastic DIP
MAX690AESA	-40°C to +85°C	8 SO
MAX690AMJA	-55°C to +125°C	8 CERDIP**

Ordering Information continued on last page.

* Dice are specified at $T_A = +25^\circ\text{C}$

** Contact factory for availability and processing to MIL-STD-883.

Pin Configurations

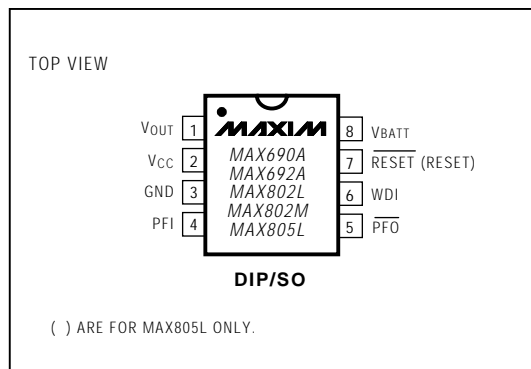

Microprocessor Supervisory Circuits

ABSOLUTE MAXIMUM RATINGS

Terminal Voltage (with respect to GND)		Rate of Rise, V_{CC} , V_{BATT} 100V/ μ s
V_{CC}	-0.3V to 6.0V	Continuous Power Dissipation
V_{BATT}	-0.3V to 6.0V	Plastic DIP (derate 9.09mW/ $^{\circ}$ C above +70 $^{\circ}$ C)
All Other Inputs (Note 1)	-0.3V to (V_{CC} + 0.3V)	SO (derate 5.88mW/ $^{\circ}$ C above +70 $^{\circ}$ C)
Input Current		CERDIP (derate 8.00mW/ $^{\circ}$ C above +70 $^{\circ}$ C)
V_{CC}	200mA	Operating Temperature Ranges:
V_{BATT}	50mA	MAX69_AC_, MAX80_C_
GND	20mA	MAX69_AE_, MAX80_E_
Output Current		MAX69_AMJA, MAX805LMJA
V_{OUT}	Short-Circuit Protected for up to 10sec	Storage Temperature Range
All Other Outputs	20mA	Lead Temperature (soldering, 10sec)

Note 1: The input voltage limits on PFI and WDI may be exceeded if the current into these pins is limited to less than 10mA.

Stresses beyond those listed under "Absolute Maximum Ratings" may cause permanent damage to the device. These are stress ratings only, and functional operation of the device at these or any other conditions beyond those indicated in the operational sections of the specifications is not implied. Exposure to absolute maximum rating conditions for extended periods may affect device reliability.

ELECTRICAL CHARACTERISTICS

(V_{CC} = 4.75V to 5.5V for MAX690A/MAX802L/MAX805L, V_{CC} = 4.5V to 5.5V for MAX692A/MAX802M, V_{BATT} = 2.8V, T_A = T_{MIN} to T_{MAX} , unless otherwise noted.)

PARAMETER	SYMBOL	CONDITIONS	MIN	TYP	MAX	UNITS
Operating Voltage Range, V_{CC} , V_{BATT} (Note 2)		MAX69_AC, MAX802_C	1.0		5.5	V
		MAX805LC	1.1		5.5	
		MAX69_AE/M, MAX80_E	1.2		5.5	
Supply Current (Excluding I_{OUT})	I_{SUPPLY}	MAX69_AC, MAX802_C		200	350	μ A
		MAX69_AE/M, MAX802_E, MAX805LE/M		200	500	
I_{SUPPLY} in Battery-Backup Mode (Excluding I_{OUT})		V_{CC} = 0V, V_{BATT} = 2.8V	T_A = +25 $^{\circ}$ C	0.05	1.0	μ A
			T_A = T_{MIN} to T_{MAX}		5.0	
V_{BATT} Standby Current (Note 3)		5.5V > V_{CC} > V_{BATT} + 0.2V	T_A = +25 $^{\circ}$ C	-0.1	0.02	μ A
			T_A = T_{MIN} to T_{MAX}	-1.0	0.02	
V_{OUT} Output		I_{OUT} = 5mA	V_{CC} - 0.05	V_{CC} - 0.025		V
		I_{OUT} = 50mA	V_{CC} - 0.5	V_{CC} - 0.25		
V_{OUT} in Battery-Backup Mode		I_{OUT} = 250 μ A, V_{CC} < V_{BATT} - 0.2V	V_{BATT} - 0.1	V_{BATT} - 0.02		V
Battery Switch Threshold, V_{CC} to V_{BATT}		V_{CC} < V_{RT}	Power-up	20		mV
			Power-down	-20		
Battery Switchover Hysteresis				40		mV
Reset Threshold	V_{RT}	MAX690A, MAX802L, MAX805L	4.50	4.65	4.75	V
		MAX692A, MAX802M	4.25	4.40	4.50	
		MAX802L, T_A = +25 $^{\circ}$ C, V_{CC} falling	4.55		4.70	
		MAX802M, T_A = +25 $^{\circ}$ C, V_{CC} falling	4.30		4.45	
Reset Threshold Hysteresis				40		mV
Reset Pulse Width	t_{RS}		140	200	280	ms
RESET Output Voltage		I_{SOURCE} = 800 μ A	V_{CC} - 1.5			V
		I_{SINK} = 3.2mA	0.4			
		MAX69_AC, MAX802_C, V_{CC} = 1.0V I_{SINK} = 50 μ A	0.3			
		MAX69_AE/M, MAX802_E, V_{CC} = 1.2V, I_{SINK} = 100 μ A	0.3			

Microprocessor Supervisory Circuits

ELECTRICAL CHARACTERISTICS (continued)

($V_{CC} = 4.75V$ to $5.5V$ for MAX690A/MAX802L/MAX805L, $V_{CC} = 4.5V$ to $5.5V$ for MAX692A/MAX802M, $V_{BATT} = 2.8V$, $T_A = T_{MIN}$ to T_{MAX} , unless otherwise noted.)

PARAMETER	SYMBOL	CONDITIONS	MIN	TYP	MAX	UNITS
RESET Output Voltage		MAX805LC, $I_{SOURCE} = 4\mu A$, $V_{CC} = 1.1V$	0.8			V
		MAX805LE/M, $I_{SOURCE} = 4\mu A$, $V_{CC} = 1.2V$	0.9			
		MAX805L, $I_{SOURCE} = 800\mu A$	$V_{CC} - 1.5$			
		MAX805L, $I_{SINK} = 3.2mA$			0.4	
Watchdog Timeout	t_{WD}		1.00	1.60	2.25	sec
WDI Pulse Width	t_{WP}	$V_{IL} = 0.4V$, $V_{IH} = (0.8)(V_{CC})$	50			ns
WDI Input Threshold (Note 4)		$V_{CC} = 5V$	Logic low		0.8	V
			Logic high	3.5		
WDI Input Current		$WDI = V_{CC}$		50	150	μA
		$WDI = 0V$	-150	-50		
PFI Input Threshold		MAX69_A, MAX805L, $V_{CC} = 5V$	1.20	1.25	1.30	V
		MAX802_C/E, $V_{CC} = 5V$	1.225	1.250	1.275	
PFI Input Current			-25	0.01	25	nA
PFO Output Voltage		$I_{SOURCE} = 800\mu A$	$V_{CC} - 1.5$			V
		$I_{SINK} = 3.2mA$			0.4	

Note 2: Either V_{CC} or V_{BATT} can go to 0V, if the other is greater than 2.0V.

Note 3: "-" = battery-charging current, "+" = battery-discharging current.

Note 4: WDI is guaranteed to be in an intermediate, non-logic level state if WDI is floating and V_{CC} is in the operating voltage range. WDI is internally biased to 35% of V_{CC} with an input impedance of 50k Ω .

MAX690A/MAX692A/MAX802L/MAX802M/MAX805L

Microprocessor Supervisory Circuits

Typical Operating Characteristics

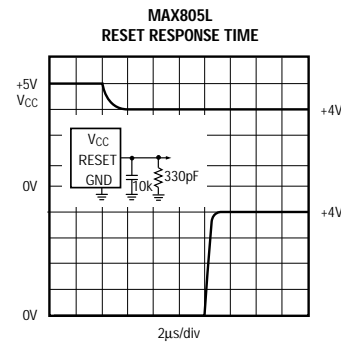
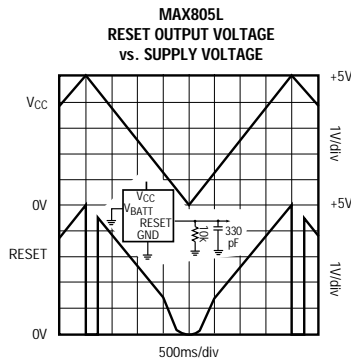
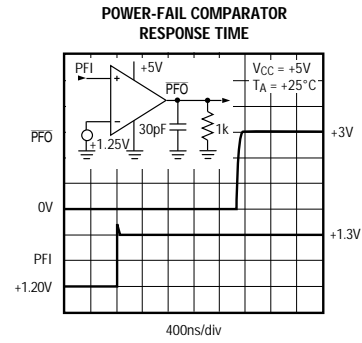
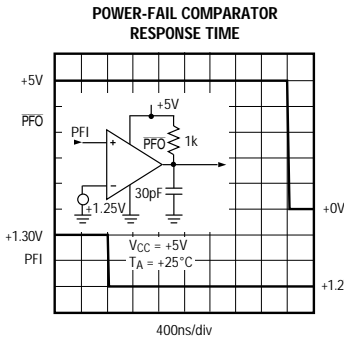
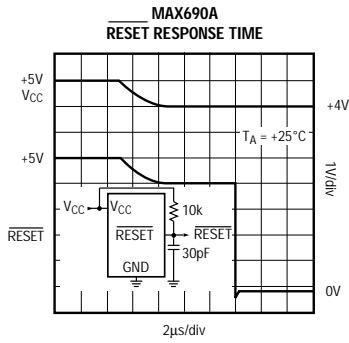
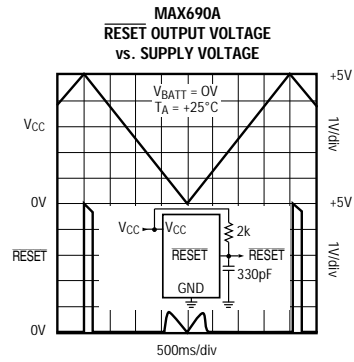
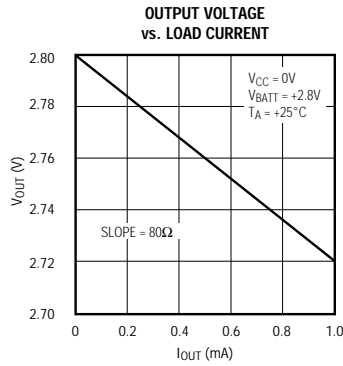
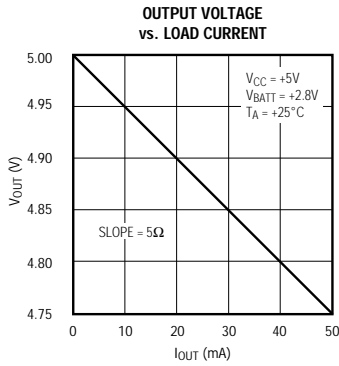

Microprocessor Supervisory Circuits

Pin Description

PIN		NAME	FUNCTION
MAX690A/MAX692A MAX802L/MAX802M	MAX805L		
1	1	V_{OUT}	Supply Output for CMOS RAM. When V_{CC} is above the reset threshold, V_{OUT} connects to V_{CC} through a P-channel MOSFET switch. When V_{CC} is below the reset threshold, the higher of V_{CC} or V_{BATT} will be connected to V_{OUT} .
2	2	V_{CC}	+5V Supply Input
3	3	GND	Ground
4	4	PFI	Power-Fail Comparator Input. When PFI is less than 1.25V, PFO goes low. Connect PFI to GND or V_{CC} when not used.
5	5	PFO	Power-Fail Output. When PFI is less than 1.25V, PFO goes low; otherwise PFO stays high.
6	6	WDI	Watchdog Input. If WDI remains high or low for 1.6sec, the internal watchdog timer runs out and reset is triggered. If WDI is left floating or connected to a high-impedance three-state buffer, the watchdog feature is disabled. The internal watchdog timer clears whenever reset is asserted, WDI is three-stated, or WDI sees a rising or falling edge.
7		RESET	Reset Output. Whenever RESET is triggered, it pulses low for 200ms. It stays low when V_{CC} is below the reset threshold (4.65V in the MAX690A/MAX802L and 4.4V in the MAX692A/MAX802M) and remains low for 200ms after V_{CC} rises above the reset threshold. A watchdog timeout also triggers RESET .
-	7	RESET	Active-High Reset Output is the inverse of RESET . When RESET is asserted, the RESET output voltage = V_{CC} or V_{BATT} , whichever is higher.
8	8	V_{BATT}	Backup-Battery Input. When V_{CC} falls below the reset threshold, V_{BATT} will be switched to V_{OUT} if V_{BATT} is 20mV greater than V_{CC} . When V_{CC} rises to 20mV above V_{BATT} , V_{OUT} will be reconnected to V_{CC} . The 40mV hysteresis prevents repeated switching if V_{CC} falls slowly.

MAX690A/MAX692A/MAX802L/MAX802M/MAX805L

Microprocessor Supervisory Circuits

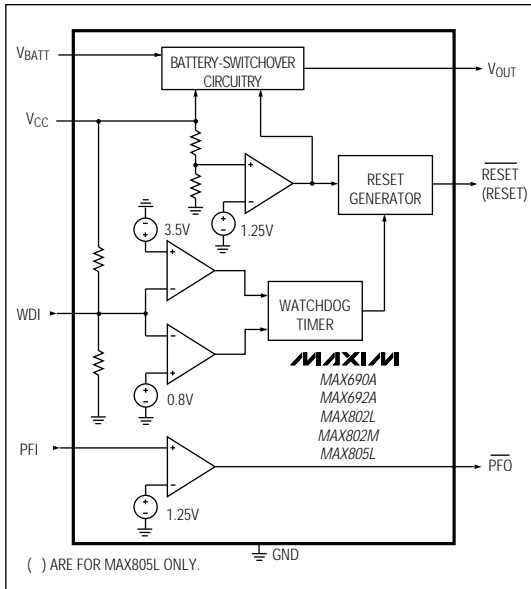

Figure 1. Block Diagram

Detailed Description

Reset Output

A microprocessor's (μ P's) reset input starts the μ P in a known state. When the μ P is in an unknown state, it should be held in reset. The MAX690A/MAX692A/MAX802L/MAX802M assert reset during power-up and prevent code execution errors during power-down or brownout conditions.

On power-up, once V_{CC} reaches 1V, **RESET** is guaranteed to be a logic low. As V_{CC} rises, **RESET** remains low. When V_{CC} exceeds the reset threshold, an internal timer keeps **RESET** low for a time equal to the reset pulse width; after this interval, **RESET** goes high (Figure 2). If a brownout condition occurs (if V_{CC} dips below the reset threshold), **RESET** is triggered. Each time **RESET** is triggered, it stays low for the reset pulse width interval. Any time V_{CC} goes below the reset threshold, the internal timer restarts the pulse. If a brownout condition interrupts a previously initiated reset pulse, the reset pulse continues for another 200ms. On power-down, once V_{CC} goes below the threshold, **RESET** is guaranteed to be logic low until V_{CC} droops below 1V.

RESET is also triggered by a watchdog timeout. If a high or low is continuously applied to the WDI pin for 1.6sec, **RESET** pulses low. As long as **RESET** is assert-

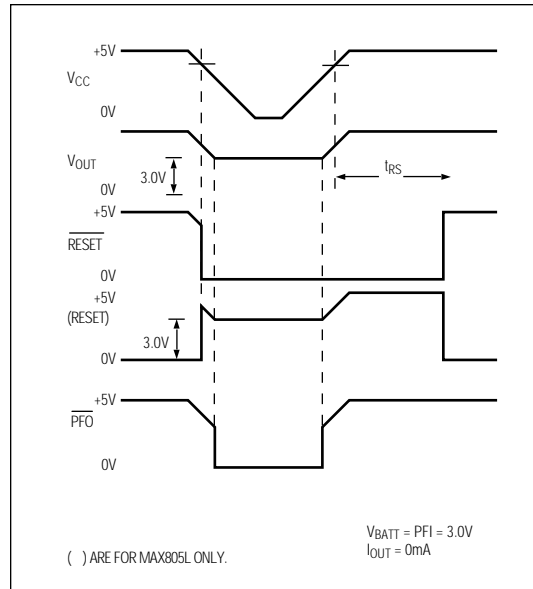

Figure 2. Timing Diagram

ed, the watchdog timer remains clear. When **RESET** comes high, the watchdog resumes timing and must be serviced within 1.6sec. If WDI is tied high or low, a **RESET** pulse is triggered every 1.8sec (t_{WD} plus t_{RS}).

The MAX805L active-high **RESET** output is the inverse of the MAX690A/MAX692A/MAX802L/MAX802M **RESET** output, and is guaranteed to be valid with V_{CC} down to 1.1V. Some μ Ps, such as Intel's 80C51, require an active-high reset pulse.

Watchdog Input

The watchdog circuit monitors the μ P's activity. If the μ P does not toggle the watchdog input (WDI) within 1.6sec, a reset pulse is triggered. The internal 1.6sec timer is cleared by either a reset pulse or by open circuiting the WDI input. As long as reset is asserted or the WDI input is open circuited, the timer remains cleared and does not count. As soon as reset is released or WDI is driven high or low, the timer starts counting. It can detect pulses as short as 50ns.

Power-Fail Comparator

The PFI input is compared to an internal 1.25V reference. If PFI is less than 1.25V, **PFO** goes low. The power-fail comparator is intended for use as an under-voltage detector to signal a failing power supply; it

Microprocessor Supervisory Circuits

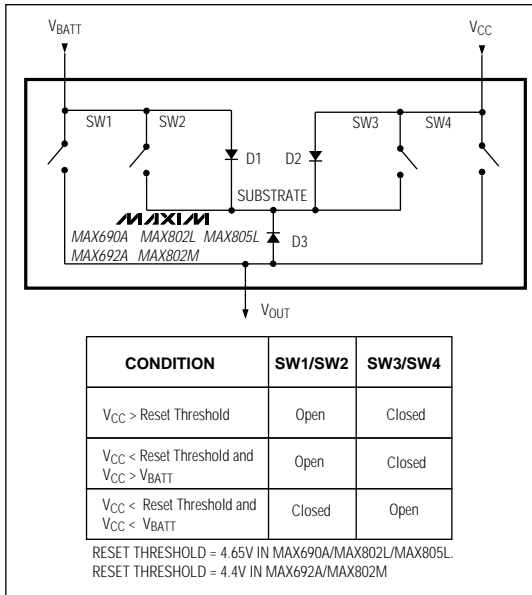

Figure 3. Backup-Battery Switchover Block Diagram

need not be dedicated to this function though, as it is completely separate from the rest of the circuitry. The external voltage divider drives PFI to sense the unregulated DC input to the +5V regulator (see *Typical Operating Circuit*). The voltage-divider ratio can be chosen such that the voltage at PFI falls below 1.25V just before the +5V regulator drops out. PFO then triggers an interrupt which signals the μ P to prepare for power-down.

To conserve backup-battery power, the power-fail detector comparator is turned off and PFO is forced low when V_{BATT} connects to V_{OUT}.

Backup-Battery Switchover

In the event of a brownout or power failure, it may be necessary to preserve the contents of RAM. With a backup battery installed at V_{BATT}, the devices automatically switch RAM to backup power when V_{CC} fails.

As long as V_{CC} exceeds the reset threshold, V_{OUT} connects to V_{CC} through a 5 Ω PMOS power switch. Once V_{CC} falls below the reset threshold, V_{CC} or V_{BATT} (whichever is higher) switches to V_{OUT}. Unlike the MAX690/MAX692, the MAX690A/MAX692A/MAX802L/MAX802M/MAX805L don't always connect V_{BATT} to V_{OUT} when V_{BATT} is greater than V_{CC}. V_{BATT} connects to V_{OUT} (through an 80 Ω switch) only when V_{CC} is below the reset threshold **and** V_{BATT} is greater

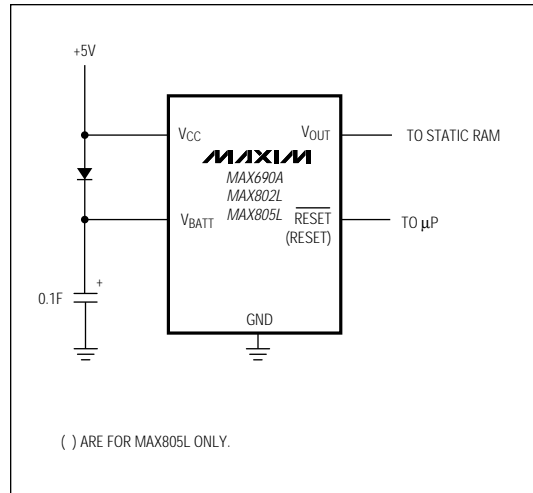

Figure 4. Using a SuperCap as a Backup Power Source with a MAX690A/MAX802L/MAX805L and a +5V \pm 5% Supply

than V_{CC}.

When V_{CC} exceeds the reset threshold, it is connected to the MAX690A/MAX692A/MAX802L/MAX802M/MAX805L substrate, regardless of the voltage applied to V_{BATT} (Figure 3). During this time, the diode (D1) between V_{BATT} and the substrate will conduct current from V_{BATT} to V_{CC} if

Table 1. Input and Output Status in Battery-Backup Mode

SIGNAL	STATUS
V _{CC}	Disconnected from V _{OUT}
V _{OUT}	Connected to V _{BATT} through an internal 80 Ω PMOS switch
V _{BATT}	Connected to V _{OUT} . Current drawn from the battery is less than 1 μ A, as long as V _{CC} < V _{BATT} - 1V.
PFI	Power-fail comparator is disabled.
PFO	Logic low
RESET	Logic low
RESET	Logic high (MAX805L only)
WDI	Watchdog timer is disabled

Microprocessor Supervisory Circuits

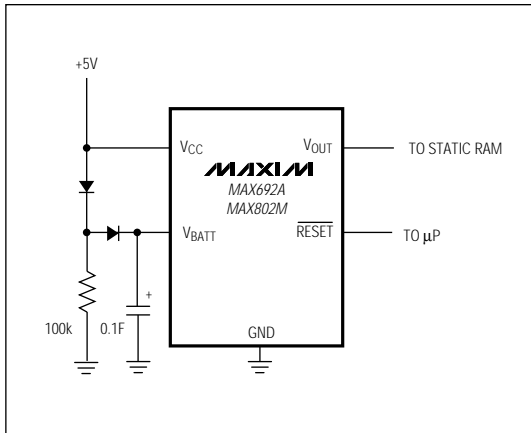

Figure 5. Using a SuperCap™ as a Backup Power Source with the MAX692A/MAX802M and a +5V ±10% Supply

V_{BATT} is 0.6V or greater than V_{CC} .

When V_{BATT} connects to V_{OUT} , backup mode is activated and the internal circuitry is powered from the battery (Table 1). When V_{CC} is just below V_{BATT} , the current drawn from V_{BATT} is typically 30μA. When V_{CC} drops to more than 1V below V_{BATT} , the internal switchover comparator shuts off and the supply current falls to less than 1μA.

Applications Information

Using a SuperCap™ as a Backup Power Source

SuperCaps are capacitors with extremely high capacitance values, on the order of 0.1F. Figure 4 shows a SuperCap used as a backup power source. Do not allow the SuperCap's voltage to exceed the maximum reset threshold by more than 0.6V. In Figure 4's circuit, the SuperCap rapidly charges to within a diode drop of V_{CC} . However, after a long time, the diode leakage current will pull the SuperCap voltage up to V_{CC} . When using a SuperCap with the MAX690A/MAX802L/MAX805L, V_{CC} may not exceed $4.75V + 0.6V = 5.35V$.

Use the SuperCap circuit of Figure 5 with a MAX692A or MAX802M and a ±10% supply. This circuit ensures that the SuperCap only charges to $V_{CC} - 0.5V$. At the maximum V_{CC} of 5.5V, the SuperCap charges up to 5.0V, only 0.5V above the maximum reset threshold—well within the requisite 0.6V.

™SuperCap is a trademark of Baknor Industries.

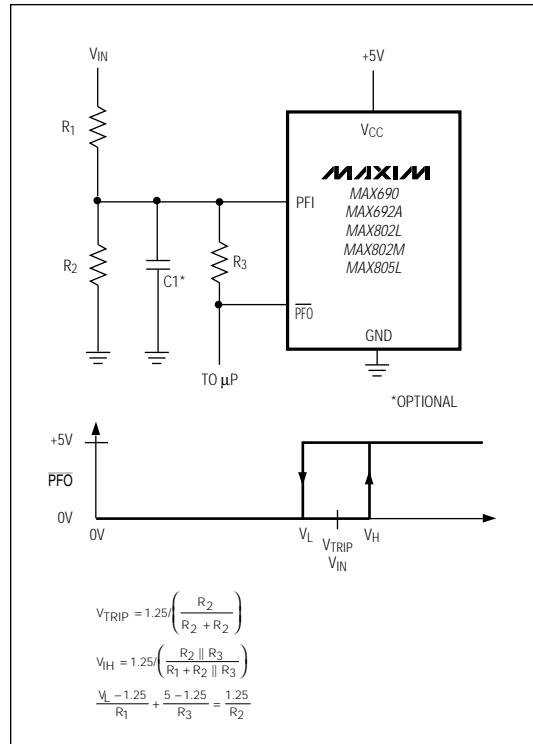

Figure 6. Adding Hysteresis to the Power-Fail Comparator

Allowable Backup Power-Source Batteries

Lithium batteries work very well as backup batteries due to very low self-discharge rates and high energy density. Single lithium batteries with open-circuit voltages of 3.0V to 3.6V are ideal. Any battery with an open-circuit voltage less than the minimum reset threshold plus 0.3V can be

Table 2. Allowable Backup-Battery Voltages

(see Using a SuperCap as a Backup Power Source section for use with a SuperCap)

PART NO.	MAXIMUM BACKUP-BATTERY VOLTAGE (V)
MAX690A/ MAX802L/MAX805L	4.80
MAX692A/ MAX802M	4.55

Microprocessor Supervisory Circuits

connected directly to the V_{BATT} input of the MAX690A/MAX692A/MAX802L/MAX802M/MAX805L with no additional circuitry (see the *Typical Operating Circuit*). However, batteries with open-circuit voltages that are greater **cannot** be used for backup, as current is sourced into the substrate through the diode (D1 in Figure 3) when V_{CC} is close to the reset threshold.

Operation Without a Backup Power Source

If a backup power source is not used, ground V_{BATT} and connect V_{OUT} to V_{CC} . Since there is no need to switch over to any backup power source, V_{OUT} does not need to be switched. A direct connection to V_{CC} eliminates any voltage drops across the switch which may push V_{OUT} below V_{CC} .

Replacing the Backup Battery

The backup battery can be removed while V_{CC} remains valid, without danger of triggering RESET/RESET. As long as V_{CC} stays above the reset threshold, battery-backup mode cannot be entered. In other switchover

ICs where battery-backup mode is entered whenever V_{BATT} gets close to V_{CC} , an unconnected V_{BATT} pin accumulates leakage charge and triggers RESET/RESET in error.

Adding Hysteresis to the Power-Fail Comparator

Hysteresis adds a noise margin to the power-fail comparator and prevents repeated triggering of PFO when V_{IN} is close to its trip point. Figure 6 shows how to add hysteresis to the power-fail comparator. Select the ratio of R_1 and R_2 such that PFI sees 1.25V when V_{IN} falls to its trip point (V_{TRIP}). R_3 adds the hysteresis. It will typically be an order of magnitude greater than R_1 or R_2 (about 10 times either R_1 or R_2). The current through R_1 and R_2 should be at least 1 μ A to ensure that the 25nA (max) PFI input current does not shift the trip point. R_3 should be larger than 10k Ω so it does not load down the PFO pin. Capacitor C1 adds additional noise rejection.

Monitoring a Negative Voltage

The power-fail comparator can be used to monitor a negative supply rail using the circuit of Figure 7. When the negative rail is good (a negative voltage of large magnitude), PFO is low. When the negative rail is degraded (a negative voltage of lesser magnitude), PFO goes high. This circuit's accuracy is affected by the PFI threshold tolerance, the V_{CC} line, and the resistors.

Interfacing to μ Ps with Bidirectional Reset Pins

μ Ps with bidirectional reset pins, such as the Motorola 68HC11 series, can contend with the MAX690A/MAX692A/MAX802L/MAX802M RESET output. If, for example, the RESET output is driven high and the μ P wants to pull it low, indeterminate logic levels may result. To correct this, connect a 4.7k Ω resistor between the RESET output and the μ P reset I/O, as in Figure 8. Buffer the RESET output to other system components

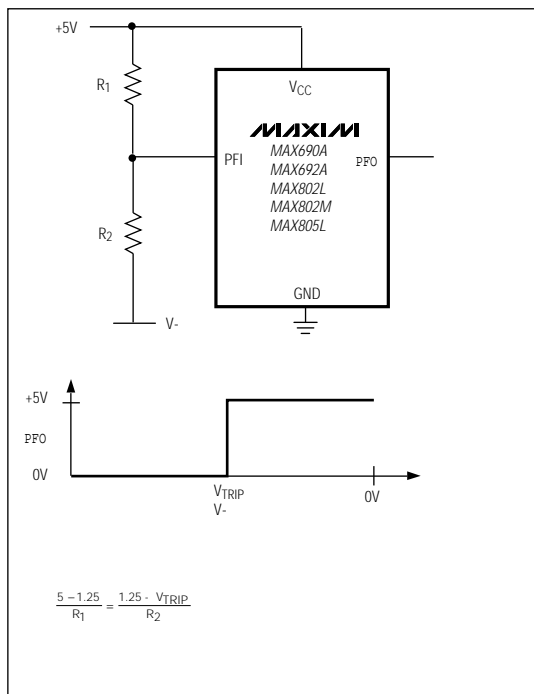

Figure 7. Monitoring a Negative Voltage

Microprocessor Supervisory Circuits

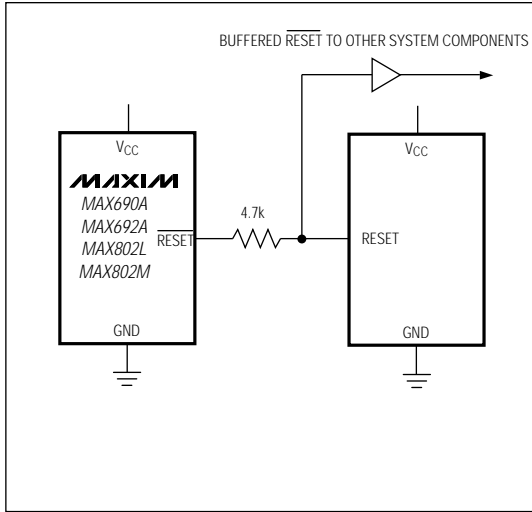

Figure 8. Interfacing to μ Ps with Bidirectional Reset I/O

Microprocessor Supervisory Circuits

μP Supervisory Circuits

Part Number	Nominal Reset Threshold (V)	Minimum Reset Pulse Width (ms)	Nominal Watchdog Timeout Period (sec)	Backup-Battery Switch	CE - Write Protect	Power-Fail Com-parator	Manual-Reset Input	Watch-dog Output	Low-Line Output	Active-High Reset	Battery-On Output
MAX690A/692A	4.65/4.40	140	1.6	✓		✓					
MAX691A/693A	4.65/4.40	140/adj.	1.6/adj.	✓	✓/10ns	✓		✓	✓	✓	✓
MAX696	Adj.	35/adj.	1.6/adj.	✓		✓		✓	✓	✓	✓
MAX697	Adj.	35/adj.	1.6/adj.		✓	✓		✓	✓	✓	
MAX700	4.65/adj.	200	-				✓			✓	
MAX703/704	4.65/4.40	140	-	✓		✓	✓				
MAX705/706	4.65/4.40	140	1.6			✓	✓	✓			
MAX706P	2.63	140	1.6			✓	✓	✓		✓	
MAX706R/S/T	2.63/2.93/ 3.08	140	1.6			✓	✓	✓			
MAX707/708	4.65/4.40	140	-			✓	✓			✓	
MAX708R/S/T	2.63/2.93/ 3.08	140	-			✓	✓			✓	
MAX709L/M/ R/S/T	4.65/4.40/ 2.63/2.93/3.08	140	-								
MAX791	4.65	140	1	✓	✓/10ns	✓	✓	✓	✓	✓	✓
MAX792L/M/ R/S/T	4.65/4.40/ 2.63/2.93/3.08	140	1		✓/10ns	✓	✓	✓	✓	✓	
MAX800L/M	4.60/4.40	140	1.6/adj.	✓	✓/10ns	✓/±2%		✓	✓	✓	✓
MAX802L/M	4.60/4.40	140	1.6	✓		✓/±2%					
MAX805L	4.65	140	1.6	✓		✓				✓	
MAX813L	4.65	140	1.6			✓	✓	✓		✓	
MAX820L/M/ R/S/T	4.65/4.40/ 2.63/2.93/3.08	140	1		✓/10ns	✓/±2%	✓	✓	✓	✓	
MAX1232	4.37/4.62	250	0.15/0.60/1.2				✓			✓	
MAX1259	-	-	-	✓		✓					

MAX690A/MAX692A/MAX693A/MAX696/MAX697/MAX700/MAX703/MAX704/MAX705/MAX706/MAX706P/MAX706R/S/T/MAX707/MAX708/MAX708R/S/T/MAX709L/M/MAX709R/S/T/MAX791/MAX792L/M/MAX792R/S/T/MAX800L/M/MAX800R/M/MAX802L/M/MAX802R/M/MAX805L/MAX813L/MAX820L/M/MAX820R/M/MAX1232/MAX1259

Microprocessor Supervisory Circuits

Ordering Information (continued)

PART	TEMP. RANGE	PIN-PACKAGE
MAX692A CPA	0°C to +70°C	8 Plastic DIP
MAX692ACESA	0°C to +70°C	8 SO
MAX692AC/D	0°C to +70°C	Dice*
MAX692AEPA	-40°C to +85°C	8 Plastic DIP
MAX692AESA	-40°C to +85°C	8 SO
MAX692AMJA	-55°C to +125°C	8 CERDIP**
MAX802L CPA	0°C to +70°C	8 Plastic DIP
MAX802LCESA	0°C to +70°C	8 SO
MAX802LEPA	-40°C to +85°C	8 Plastic DIP
MAX802LESA	-40°C to +85°C	8 SO
MAX802M CPA	0°C to +70°C	8 Plastic DIP
MAX802MCESA	0°C to +70°C	8 SO
MAX802MEPA	-40°C to +85°C	8 Plastic DIP
MAX802MESA	-40°C to +85°C	8 SO
MAX805L CPA	0°C to +70°C	8 Plastic DIP
MAX805LCESA	0°C to +70°C	8 SO
MAX805LC/D	0°C to +70°C	Dice*
MAX805LEPA	-40°C to +85°C	8 Plastic DIP
MAX805LESA	-40°C to +85°C	8 SO
MAX805LMJA	-55°C to +125°C	8 CERDIP**

* Dice are specified at $T_A = +25^\circ\text{C}$.

** Contact factory for availability and processing to MIL-STD-883.

Chip Topography

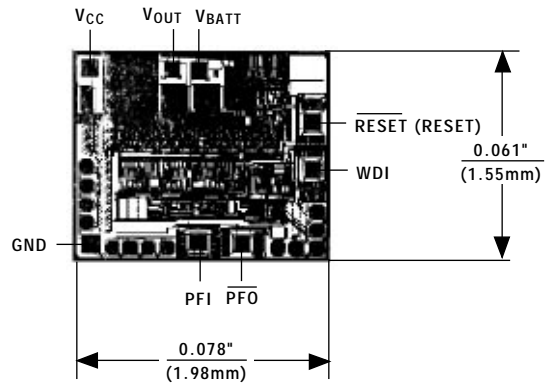

() ARE FOR MAX805L ONLY.
 TRANSISTOR COUNT: 573;
 SUBSTRATE MUST BE LEFT UNCONNECTED.

Maxim cannot assume responsibility for use of any circuitry other than circuitry entirely embodied in a Maxim product. No circuit patent licenses are implied. Maxim reserves the right to change the circuitry and specifications without notice at any time.

12 _____ Maxim Integrated Products, 120 San Gabriel Drive, Sunnyvale, CA 94086 (408) 737-7600

© 1993 Maxim Integrated Products

Printed USA

MAXIM is a registered trademark of Maxim Integrated Products.