



## Quad, Rail-to-Rail, Fault-Protected, SPST Analog Switches

### General Description

The MAX4511/MAX4512/MAX4513 are quad, single-pole/single-throw (SPST), fault-protected analog switches. They are pin-compatible with the industry-standard nonprotected DG201/DG202/DG213. These new switches feature fault-protected inputs and Rail-to-Rail<sup>®</sup> signal handling capability. The normally open (NO<sub>-</sub>) and normally closed (NC<sub>-</sub>) terminals are protected from overvoltage faults up to 36V during power-up or power-down. During a fault condition, the NO<sub>-</sub> or NC<sub>-</sub> terminal becomes an open circuit and only nanoamperes of leakage current flow from the source, but the switch output (COM<sub>-</sub>) furnishes up to 10mA of the appropriate polarity supply voltage to the load. This ensures unambiguous rail-to-rail outputs when a fault begins and ends.

On-resistance is 175Ω max and is matched between switches to 10Ω max. The off-leakage current is only 0.5nA at +25°C and 10nA at +85°C.

The MAX4511 has four normally closed switches. The MAX4512 has four normally open switches. The MAX4513 has two normally closed and two normally open switches.

These CMOS switches can operate with dual power supplies ranging from ±4.5V to ±18V or a single supply between +9V and +36V.

All digital inputs have +0.8V and +2.4V logic thresholds, ensuring both TTL- and CMOS-logic compatibility when using ±15V or a single +12V supply.

### Applications

ATE Equipment  
Data Acquisition  
Industrial and Process-Control Systems  
Avionics  
Redundant/Backup Systems

### Ordering Information

PART	TEMP. RANGE	PIN-PACKAGE
MAX4511CPE	0°C to +70°C	16 Plastic DIP
MAX4511CSE	0°C to +70°C	16 Narrow SO
MAX4511C/D	0°C to +70°C	Dice*
MAX4511EPE	-40°C to +85°C	16 Plastic DIP
MAX4511ESE	-40°C to +85°C	16 Narrow SO
MAX4511MJE	-55°C to +125°C	16 CERDIP

Ordering Information continued at end of data sheet.

\*Contact factory for dice specifications.

Rail-to-Rail is a registered trademark of Nippon Motorola, Ltd.

### Features

- ♦ ±40V Fault Protection with Power Off
- ♦ ±36V Fault Protection with ±15V Supplies
- ♦ All Switches Off with Power Off
- ♦ Rail-to-Rail Signal Handling
- ♦ Output Clamped to Appropriate Supply Voltage During Fault Condition; No Transition Glitch
- ♦ 175Ω max Signal Paths with ±15V Supplies
- ♦ No Power-Supply Sequencing Required
- ♦ ±4.5V to ±18V Dual Supplies
- ♦ +9V to +36V Single Supply
- ♦ Low Power Consumption, <2mW
- ♦ Four Separately Controlled SPST Switches
- ♦ Pin-Compatible with Industry-Standard DG411/DG412/DG413, DG201/DG202/DG213
- ♦ TTL- and CMOS-Compatible Logic Inputs with Single +9V to +15V or ±15V Supplies

### Pin Configurations/ \_Functional Diagrams/Truth Tables

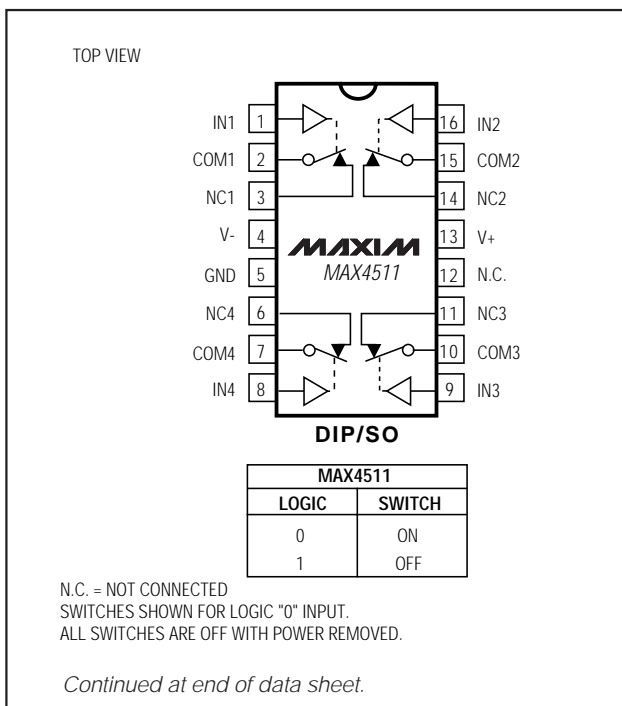

MAX4511/MAX4512/MAX4513



# Quad, Rail-to-Rail, Fault-Protected, SPST Analog Switches

## ABSOLUTE MAXIMUM RATINGS

(Voltages Referenced to GND)

V+	-0.3V to +44.0V
V-	-44.0V to +0.3V
V+ to V-	-0.3V to +44.0V
COM <sub>-</sub> , IN <sub>-</sub> (Note 1)	(V <sub>-</sub> - 0.3V) to (V <sub>+</sub> + 0.3V)
NC <sub>-</sub> , NO <sub>-</sub> (Note 2)	(V <sub>+</sub> - 36V) to (V <sub>-</sub> + 36V)
NC <sub>-</sub> , NO <sub>-</sub> to COM <sub>-</sub>	-36V to +36V
Continuous Current into Any Terminal	±30mA
Peak Current into Any Terminal (pulsed at 1ms, 10% duty cycle)	±50mA

Continuous Power Dissipation (T<sub>A</sub> = +70°C) (Note 2)

Plastic DIP (derate 10.53mW/°C above +70°C)	842mW
Narrow SO (derate 8.70mW/°C above +70°C)	696mW
CERDIP (derate 10.00mW/°C above +70°C)	800mW
Operating Temperature Ranges	
MAX451_C_E	0°C to +70°C
MAX451_E_E	-40°C to +85°C
MAX451_MJE	-55°C to +125°C
Storage Temperature Range	-65°C to +150°C
Lead Temperature (soldering, 10sec)	+300°C

**Note 1:** COM<sub>-</sub> and IN<sub>-</sub> pins are not fault protected. Signals on COM<sub>-</sub> or IN<sub>-</sub> exceeding V<sub>+</sub> or V<sub>-</sub> are clamped by internal diodes. Limit forward diode current to maximum current rating.

**Note 2:** NC<sub>-</sub> and NO<sub>-</sub> pins are fault protected. Signals on NC<sub>-</sub> or NO<sub>-</sub> exceeding -36V to +36V may damage the device. These limits apply with power applied to V<sub>+</sub> or V<sub>-</sub>, or ±40V with V<sub>+</sub> = V<sub>-</sub> = 0.

Stresses beyond those listed under "Absolute Maximum Ratings" may cause permanent damage to the device. These are stress ratings only, and functional operation of the device at these or any other conditions beyond those indicated in the operational sections of the specifications is not implied. Exposure to absolute maximum rating conditions for extended periods may affect device reliability.

## ELECTRICAL CHARACTERISTICS—Dual Supplies

(V<sub>+</sub> = +15V, V<sub>-</sub> = -15V, GND = 0V, T<sub>A</sub> = T<sub>MIN</sub> to T<sub>MAX</sub>, unless otherwise noted. Typical values are at T<sub>A</sub> = +25°C.)

PARAMETER	SYMBOL	CONDITIONS	T <sub>A</sub>	MIN	TYP (Note 3)	MAX	UNITS
<b>ANALOG SWITCH</b>							
Fault-Protected Analog Signal Range	V <sub>NO-</sub> , V <sub>NC-</sub>	Applies with power on or off (Note 2)	C, E, M	-36		36	V
Fault-Free Analog Signal Range	V <sub>NO-</sub> , V <sub>NC-</sub>	Applies with power on or off (Note 2)	C, E, M	V <sub>-</sub>		V <sub>+</sub>	V
Non-Protected Analog Signal Range (COM <sub>-</sub> Output)	V <sub>COM-</sub>	Applies with power on or off (Note 1)	C, E, M	V <sub>-</sub> - 0.3		V <sub>+</sub> + 0.3	V
COM <sub>-</sub> -NO <sub>-</sub> or COM <sub>-</sub> -NC <sub>-</sub> On-Resistance	R <sub>ON</sub>	V <sub>COM-</sub> = ±10V, I <sub>COM-</sub> = 1mA	+25°C	125	160		Ω
			C, E		200		
			M		250		
COM <sub>-</sub> -NO <sub>-</sub> or COM <sub>-</sub> -NC <sub>-</sub> On-Resistance Match Between Channels (Note 4)	ΔR <sub>ON</sub>	V <sub>COM-</sub> = ±10V, I <sub>COM-</sub> = 1mA	+25°C	3	6		Ω
			C, E		10		
			M		15		
NO <sub>-</sub> or NC <sub>-</sub> Off Leakage Current (Note 5)	I <sub>NO-(OFF)</sub> , I <sub>NC-(OFF)</sub>	V <sub>COM-</sub> = ±14V; V <sub>NO-</sub> , V <sub>COM-</sub> = ∓14V	+25°C	-0.5	0.01	0.5	nA
			C, E		-10	10	
			M		-200	200	
COM <sub>-</sub> Off Leakage Current (Note 5)	I <sub>COM-(OFF)</sub>	V <sub>COM-</sub> = ±14V; V <sub>NO-</sub> , V <sub>COM-</sub> = ∓14V	+25°C	-0.5	0.01	0.5	nA
			C, E		-10	10	
			M		-200	200	
COM <sub>-</sub> On Leakage Current (Note 5)	I <sub>COM-(ON)</sub>	V <sub>COM-</sub> = ±14V	+25°C	-0.5	0.01	0.5	nA
			C, E		-20	20	
			M		-400	400	

# Quad, Rail-to-Rail, Fault-Protected, SPST Analog Switches

MAX4511/MAX4512/MAX4513

## ELECTRICAL CHARACTERISTICS—Dual Supplies (continued)

(V+ = +15V, V- = -15V, GND = 0V, T<sub>A</sub> = T<sub>MIN</sub> to T<sub>MAX</sub>, unless otherwise noted. Typical values are at T<sub>A</sub> = +25°C.)

PARAMETER	SYMBOL	CONDITIONS	T <sub>A</sub>	MIN	TYP (Note 3)	MAX	UNITS	
<b>FAULT</b> (V+ = +15V, V- = -15V, unless otherwise noted.)								
COM_ Output Leakage Current, Supplies On	I <sub>COM_</sub>	V <sub>NO_</sub> or V <sub>N<sub>C_</sub></sub> = ±33V	+25°C	-10		10	nA	
			C, E	-200		200		
			M	-1		1	μA	
NO_ or NC_ Off Input Leakage Current, Supplies On	I <sub>NO_</sub> , I <sub>NC_</sub>	V <sub>NO_</sub> or V <sub>N<sub>C_</sub></sub> = ±25V, V <sub>COM_</sub> = ∓10V	+25°C	-20		20	nA	
			C, E	-200		200		
			M	-10		10	μA	
NO_ or NC_ Input Leakage Current, Supplies Off	I <sub>NO_</sub> , I <sub>NC_</sub>	V <sub>NO_</sub> or V <sub>N<sub>C_</sub></sub> = ±40V, V+ = 0, V- = 0	+25°C	-20	0.1	20	nA	
			C, E	-200		200		
			M	-10		10	μA	
COM_ On Output Current, Supplies On	I <sub>COM_</sub>	V <sub>NO_</sub> or V <sub>N<sub>C_</sub></sub> = 33V	+25°C	8	11	13	mA	
		V <sub>NO_</sub> or V <sub>N<sub>C_</sub></sub> = -33V		-12	-10	-7		
COM_ On Output Resistance, Supplies On	R <sub>COM_</sub>	V <sub>NO_</sub> or V <sub>N<sub>C_</sub></sub> = ±33V	+25°C		1	2.5	kΩ	
			C, E, M			3		
<b>LOGIC INPUT</b>								
IN_ Input Logic Threshold High	V <sub>IN_H</sub>		C, E, M		1.9	2.4	V	
IN_ Input Logic Threshold Low	V <sub>IN_L</sub>		C, E, M	0.8	1.9		V	
IN_ Input Current Logic High or Low	I <sub>INH_</sub> , I <sub>INL</sub>	V <sub>IN_</sub> = 0.8V or 2.4V	+25°C	-1	0.03	1	μA	
			C, E, M	-5		5		
<b>SWITCH DYNAMIC CHARACTERISTICS</b>								
Turn-On Time	t <sub>ON</sub>	V <sub>COM_</sub> = ±10V, R <sub>L_</sub> = 2kΩ, Figure 2	+25°C		350	500	ns	
			C, E			600		
			M			900		
Turn-Off Time	t <sub>OFF</sub>	V <sub>COM_</sub> = ±10V, R <sub>L_</sub> = 2kΩ, Figure 2	+25°C		200	400	ns	
			C, E			500		
			M			750		
Break-Before-Make Time Delay (MAX4513 Only)	t <sub>B<sub>BM</sub></sub>	V <sub>COM_</sub> = ±10V, R <sub>L_</sub> = 2kΩ, Figure 3	+25°C	50	100		ns	
Charge Injection (Note 6)	Q	C <sub>L</sub> = 1.0nF, V <sub>NO_</sub> = 0, R <sub>S</sub> = 0Ω, Figure 4	+25°C		1.5	5	pC	
NO_ or NC_ Off-Capacitance	C <sub>N_(OFF)</sub>	f = 1MHz, Figure 5	+25°C		10		pF	
COM_ Off-Capacitance	C <sub>COM_(OFF)</sub>	f = 1MHz, Figure 5	+25°C		5		pF	
COM_ On-Capacitance	C <sub>COM_(ON)</sub>	f = 1MHz, Figure 5	+25°C		10		pF	
Off Isolation (Note 7)	V <sub>C<sub>ISO</sub></sub>	R <sub>L</sub> = 50Ω, C <sub>L</sub> = 15pF, V <sub>N_</sub> = 1V <sub>RMS</sub> , f = 1MHz, Figure 6	+25°C		-62		dB	
Channel-to-Channel Crosstalk (Note 9)	V <sub>C<sub>T</sub></sub>	R <sub>L</sub> = 50Ω, C <sub>L</sub> = 15pF, V <sub>N_</sub> = 1V <sub>RMS</sub> , f = 1MHz, Figure 6	+25°C		-66		dB	

# Quad, Rail-to-Rail, Fault-Protected, SPST Analog Switches

## ELECTRICAL CHARACTERISTICS—Dual Supplies (continued)

( $V_+ = +15V$ ,  $V_- = -15V$ ,  $GND = 0V$ ,  $T_A = T_{MIN}$  to  $T_{MAX}$ , unless otherwise noted. Typical values are at  $T_A = +25^\circ C$ .)

PARAMETER	SYMBOL	CONDITIONS	$T_A$	MIN	TYP (Note 3)	MAX	UNITS
<b>POWER SUPPLY</b>							
Power-Supply Range	$V_+$ , $V_-$		C, E, M	$\pm 4.5$		$\pm 18$	V
V+ Supply Current	$I_+$	All $V_{IN\_} = 0$ or 5V	+25°C		280	400	$\mu A$
			C, E, M			600	
V- Supply Current	$I_-$	All $V_{IN\_} = 0$ or 5V	+25°C		90	200	$\mu A$
			C, E, M			300	
GND Supply Current	$I_{GND}$	All $V_{IN\_} = 0$ or 15V	+25°C	-1	0.01	1	$\mu A$
			C, E, M			10	
		All $V_{IN\_} = 5V$	+25°C		150	250	$\mu A$
			C, E, M			450	

# Quad, Rail-to-Rail, Fault-Protected, SPST Analog Switches

## ELECTRICAL CHARACTERISTICS—Single +12V Supply

(V+ = +10.8V to +13.2V, V- = 0, T<sub>A</sub> = T<sub>MIN</sub> to T<sub>MAX</sub>, unless otherwise noted. Typical values are at T<sub>A</sub> = +25°C.)

PARAMETER	SYMBOL	CONDITIONS	T <sub>A</sub>	MIN	TYP (Note 3)	MAX	UNITS
<b>ANALOG SWITCH</b>							
Fault-Protected Analog Signal Range	V <sub>NO_</sub> , V <sub>VNC_</sub>	Applies with power on or off (Note 2)	C, E, M	-36		36	V
Fault-Free Analog Signal Range	V <sub>NO_</sub> , V <sub>VNC_</sub>	Applies with power on or off (Note 2)	C, E, M	0		V+	V
Non-Protected Analog Signal Range (COM <sub>_</sub> Output)	V <sub>COM_</sub>	Applies with power on or off (Note 1)	C, E, M	-0.3		V+ + 0.3	V
COM <sub>_</sub> -NO <sub>_</sub> or COM <sub>_</sub> -NC <sub>_</sub> On-Resistance	R <sub>ON</sub>	V+ = 12V, V <sub>COM_</sub> = 10V, I <sub>COM_</sub> = 1mA	+25°C	260	390		Ω
			C, E		450		
			M		525		
COM <sub>_</sub> -NO <sub>_</sub> or COM <sub>_</sub> -NC <sub>_</sub> On-Resistance Match Between Channels (Note 4)	ΔR <sub>ON</sub>	V+ = 12V, V <sub>COM_</sub> = 10V, I <sub>COM_</sub> = 1mA	+25°C	4	10		Ω
			C, E		20		
			M		30		
NO <sub>_</sub> or NC <sub>_</sub> Off Leakage Current (Notes 5, 9)	I <sub>NO_(OFF)</sub> , I <sub>VNC_(OFF)</sub>	V+ = 12V; V <sub>COM_</sub> = 10V; V <sub>NO_</sub> , V <sub>VNC_</sub> = 0 or 12V	+25°C	-0.5	0.01	0.5	nA
			C, E		-10	10	
			M		-200	200	
COM <sub>_</sub> Off Leakage Current (Notes 5, 9)	I <sub>COM_(OFF)</sub>	V+ = 12V; V <sub>COM_</sub> = 0; V <sub>NO_</sub> , V <sub>VNC_</sub> = 12V	+25°C	-0.5	0.01	0.5	nA
			C, E		-10	10	
			M		-200	200	
COM <sub>_</sub> On Leakage Current (Notes 5, 9)	I <sub>COM_(ON)</sub>	V+ = 12V, V <sub>COM_</sub> = 10V or 12V	+25°C	-0.5	0.01	0.5	nA
			C, E		-20	20	
			M		-400	400	
<b>FAULT</b>							
COM <sub>_</sub> Output Leakage Current, Supply On	I <sub>COM_</sub>	V <sub>NO_</sub> or V <sub>VNC_</sub> = ±30V, V+ = 12V	+25°C	-10		10	nA
			C, E		-200	200	
			M		-1	1	
NO <sub>_</sub> or NC <sub>_</sub> Off Input Leakage Current, Supply On	I <sub>NO_</sub> , I <sub>VNC_</sub>	V <sub>NO_</sub> or V <sub>VNC_</sub> = ±25V, V <sub>COM_</sub> = 0, V+ = 12V	+25°C	-20		20	nA
			C, E		-200	200	
			M		-10	10	
NO <sub>_</sub> or NC <sub>_</sub> Input Leakage Current, Supply Off	I <sub>NO_</sub> , I <sub>VNC_</sub>	V <sub>NO_</sub> or V <sub>VNC_</sub> = ±40V, V+ = 0, V- = 0	+25°C	-20	0.1	20	nA
			C, E		-200	200	
			M		-10	10	
COM <sub>_</sub> Output Current, Supply On	I <sub>COM_</sub>	V <sub>NO_</sub> or V <sub>VNC_</sub> = 25V, V+ = 12V	+25°C	2	3	5	mA
COM <sub>_</sub> Output Resistance, Supply On	R <sub>COM_</sub>	V <sub>NO_</sub> or V <sub>VNC_</sub> = 10V, V+ = 12V	+25°C		2.4	5	kΩ

MAX4511/MAX4512/MAX4513

# Quad, Rail-to-Rail, Fault-Protected, SPST Analog Switches

## ELECTRICAL CHARACTERISTICS—Single +12V Supply (continued)

(V+ = +10.8V to +13.2V, V- = 0, T<sub>A</sub> = T<sub>MIN</sub> to T<sub>MAX</sub>, unless otherwise noted. Typical values are at T<sub>A</sub> = +25°C.)

PARAMETER	SYMBOL	CONDITIONS	T <sub>A</sub>	MIN	TYP (Note 3)	MAX	UNITS
<b>LOGIC INPUT</b>							
IN <sub>-</sub> Input Logic Threshold High	V <sub>IN_H</sub>		C, E, M		1.8	2.4	V
IN <sub>-</sub> Input Logic Threshold Low	V <sub>IN_L</sub>		C, E, M	0.8	1.8		V
IN <sub>-</sub> Input Current Logic High or Low	I <sub>IN_H</sub> , I <sub>IN_L</sub>	V <sub>IN_-</sub> = 0.8V or 2.4V	+25°C	-1	0.03	1	μA
			C, E, M	-5		5	
<b>SWITCH DYNAMIC CHARACTERISTICS</b>							
Turn-On Time	t <sub>ON</sub>	V <sub>COM_-</sub> = 10V, R <sub>L_-</sub> = 2kΩ, Figure 2	+25°C	500	1000		ns
			C, E, M		1500		
Turn-Off Time	t <sub>OFF</sub>	V <sub>COM_-</sub> = 10V, R <sub>L_-</sub> = 2kΩ, Figure 2	+25°C	400	900		ns
			C, E, M		1200		
Break-Before-Make Time Delay (MAX4513 Only)	t <sub>BBM</sub>	V <sub>COM_-</sub> = 10V, R <sub>L_-</sub> = 2kΩ, Figure 3	+25°C	50	100		ns
Charge Injection (Note 6)	Q	C <sub>L</sub> = 1.0nF, V <sub>NO_-</sub> = 0, R <sub>S</sub> = 0Ω, Figure 4	+25°C		1	5	pC
NO <sub>-</sub> or NC <sub>-</sub> Off Capacitance	C <sub>NO_-(OFF)</sub>	f = 1MHz, Figure 5	+25°C		9		pF
COM <sub>-</sub> Off Capacitance	C <sub>COM_-(OFF)</sub>	V <sub>COM_-</sub> = GND, f = 1MHz, Figure 5	+25°C		9		pF
COM <sub>-</sub> On Capacitance	C <sub>COM_-(ON)</sub>	V <sub>COM_-</sub> = V <sub>NO_-</sub> = GND, f = 1MHz, Figure 5	+25°C		22		pF
Off Isolation (Note 7)	V <sub>ISO</sub>	R <sub>L</sub> = 50Ω, C <sub>L</sub> = 15pF, V <sub>N_-</sub> = 1V <sub>RMS</sub> , f = 1MHz, Figure 6	+25°C		-62		dB
Channel-to-Channel Crosstalk (Note 8)	V <sub>CT</sub>	R <sub>L</sub> = 50Ω, C <sub>L</sub> = 15pF, V <sub>N_-</sub> = 1V <sub>RMS</sub> , f = 1MHz, Figure 5	+25°C		-65		dB
<b>POWER SUPPLY</b>							
Power-Supply Range	V+		C, E, M	9		36	V
V+ Supply Current	I+	All V <sub>IN_-</sub> = 0 or 5V	+25°C	150	300		μA
			C, E, M		450		
V- and GND Supply Current	I <sub>GND</sub>	All V <sub>IN_-</sub> = 0 or 12V	+25°C	50	100		μA
			C, E, M		200		
		All V <sub>IN_-</sub> = 5V	+25°C	150	300		
			C, E, M		450		

**Note 1:** COM<sub>-</sub> and IN<sub>-</sub> pins are not fault protected. Signals on COM<sub>-</sub> or IN<sub>-</sub> exceeding V+ or V- are clamped by internal diodes. Limit forward diode current to maximum current rating.

**Note 2:** NC<sub>-</sub> and NO<sub>-</sub> pins are fault protected. Signals on NC<sub>-</sub> or NO<sub>-</sub> exceeding -36V to +36V may damage the device. These limits apply with power applied to V+ or V-, or ±40V with V+ = V- = 0.

**Note 3:** The algebraic convention is used in this data sheet; the most negative value is shown in the minimum column.

**Note 4:** ΔR<sub>ON</sub> = ΔR<sub>ON(MAX)</sub> - ΔR<sub>ON(MIN)</sub>.

**Note 5:** Leakage parameters are 100% tested at maximum rated hot temperature and guaranteed by correlation at T<sub>A</sub> = +25°C.

**Note 6:** Guaranteed by design.

**Note 7:** Off isolation = 20 log<sub>10</sub> [ V<sub>COM\_-</sub> / (V<sub>NC\_-</sub> or V<sub>NO\_-</sub>) ], V<sub>COM\_-</sub> = output, V<sub>NC\_-</sub> or V<sub>NO\_-</sub> = input to off switch.

**Note 8:** Between any two switches.

**Note 9:** Leakage testing for single-supply operation is guaranteed by testing with dual supplies.

# Quad, Rail-to-Rail, Fault-Protected, SPST Analog Switches

## Typical Operating Characteristics

( $T_A = +25^\circ\text{C}$ , unless otherwise noted.)

MAX4511/MAX4512/MAX4513

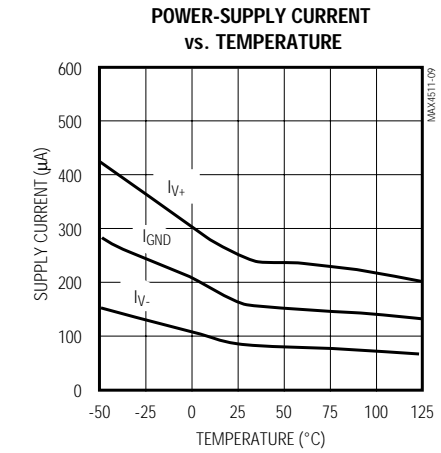
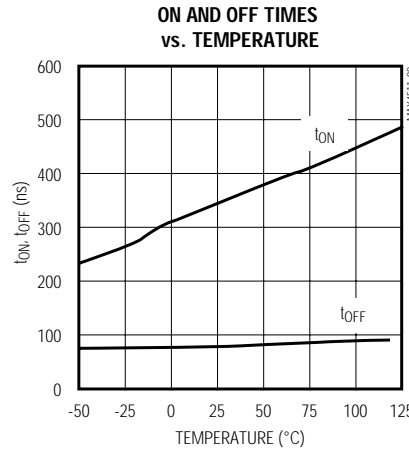
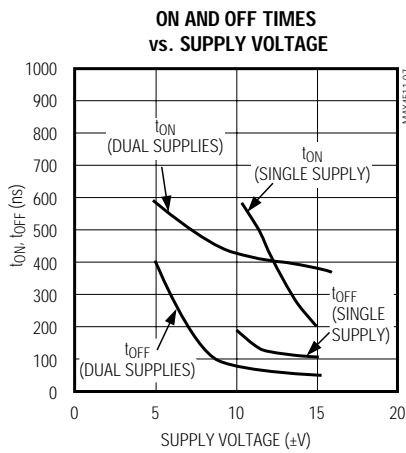
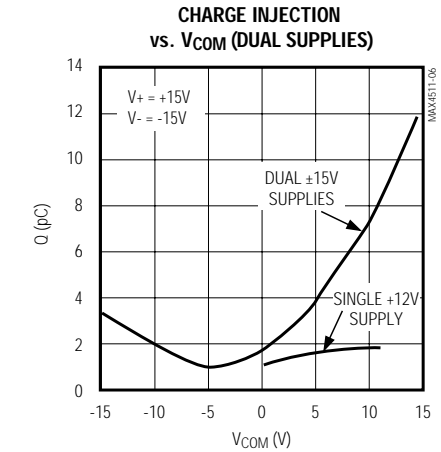
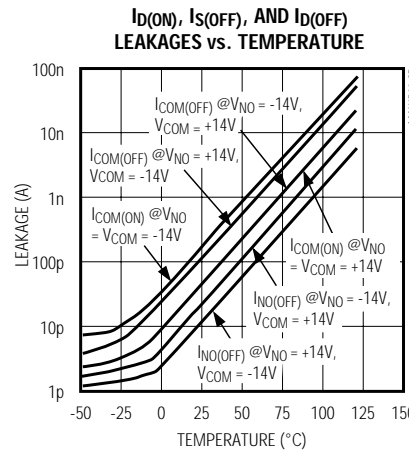
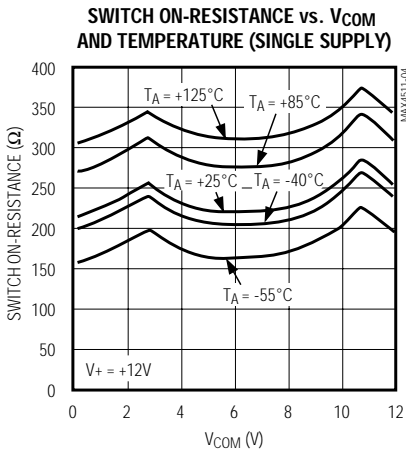
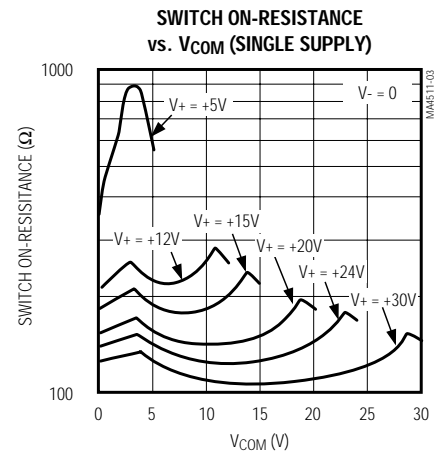
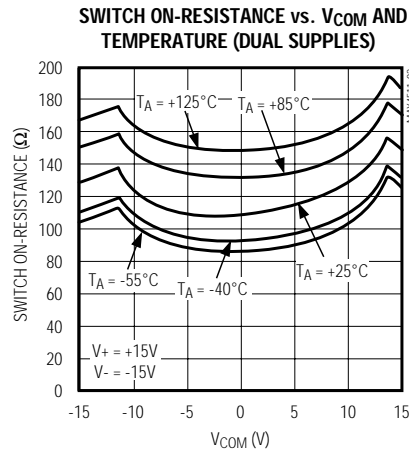
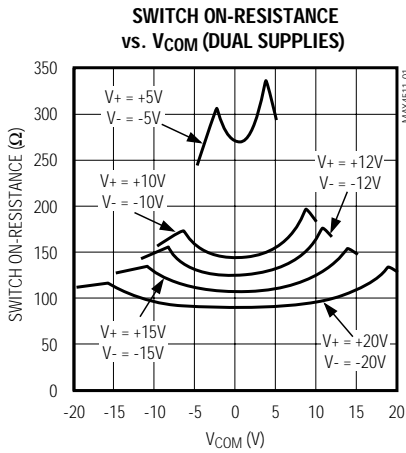

# Quad, Rail-to-Rail, Fault-Protected, SPST Analog Switches

## Typical Operating Characteristics (continued)

(T<sub>A</sub> = +25°C, unless otherwise noted.)

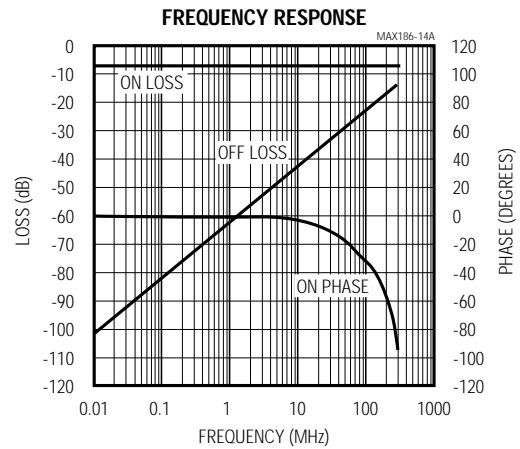
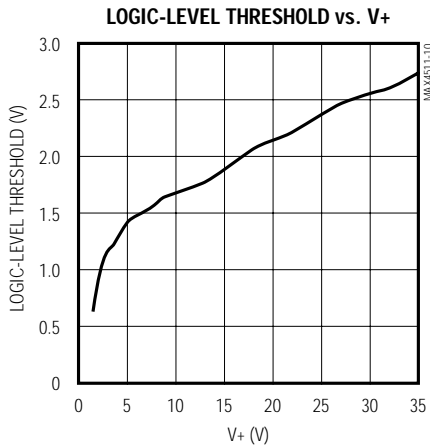

### Pin Description

PIN	NAME	FUNCTION
1, 16, 9, 8	IN1-IN4	Logic Control Digital Inputs
2, 15, 10, 7	COM1- COM4	Analog Switch Common* Terminals
3, 14, 11, 6	NO1-NO4 or NC1-NC4	Analog Switch Fault-Protected Normally Open* or Normally Closed* Terminals
4	V-	Negative Analog Supply Voltage Input. Connect to GND for single-supply operation.
5	GND	Ground. Connect to digital ground. (Analog signals have no ground reference.)
12	N.C.	No Connection—not internally connected
13	V+	Positive Analog and Digital Supply-Voltage Input. Internally connected to substrate.

\*As long as the voltage on NO<sub>-</sub> or NC<sub>-</sub> does not exceed V<sub>+</sub> or V<sub>-</sub>, NO<sub>-</sub> (or NC<sub>-</sub>) and COM<sub>-</sub> pins are identical and interchangeable. Either may be considered as an input or output; signals pass equally well in either direction.

### Detailed Description

#### Overview of Traditional Fault-Protected Switches

The MAX4511/MAX4512/MAX4513 are fault-protected CMOS analog switches with unusual operation and construction. Traditional fault-protected switches are constructed by three series FETs. This produces good off characteristics, but fairly high on-resistance when the signals are within about 3V of each supply rail. As the voltage on one side of the switch approaches within about 3V of either supply rail (a fault condition), the switch impedance becomes higher, limiting the output signal range (on the protected side of the switch) to approximately 3V less than the appropriate polarity supply voltage.

During a fault condition, the output current that flows from the protected side of the switch into its load comes from the fault source on the other side of the switch. If the switch is open or the load is extremely high impedance, the input current will be very low. If the switch is on and the load is low impedance, enough current will flow from the source to maintain the load voltage at 3V less than the supply.

# Quad, Rail-to-Rail, Fault-Protected, SPST Analog Switches

MAX4511/MAX4512/MAX4513

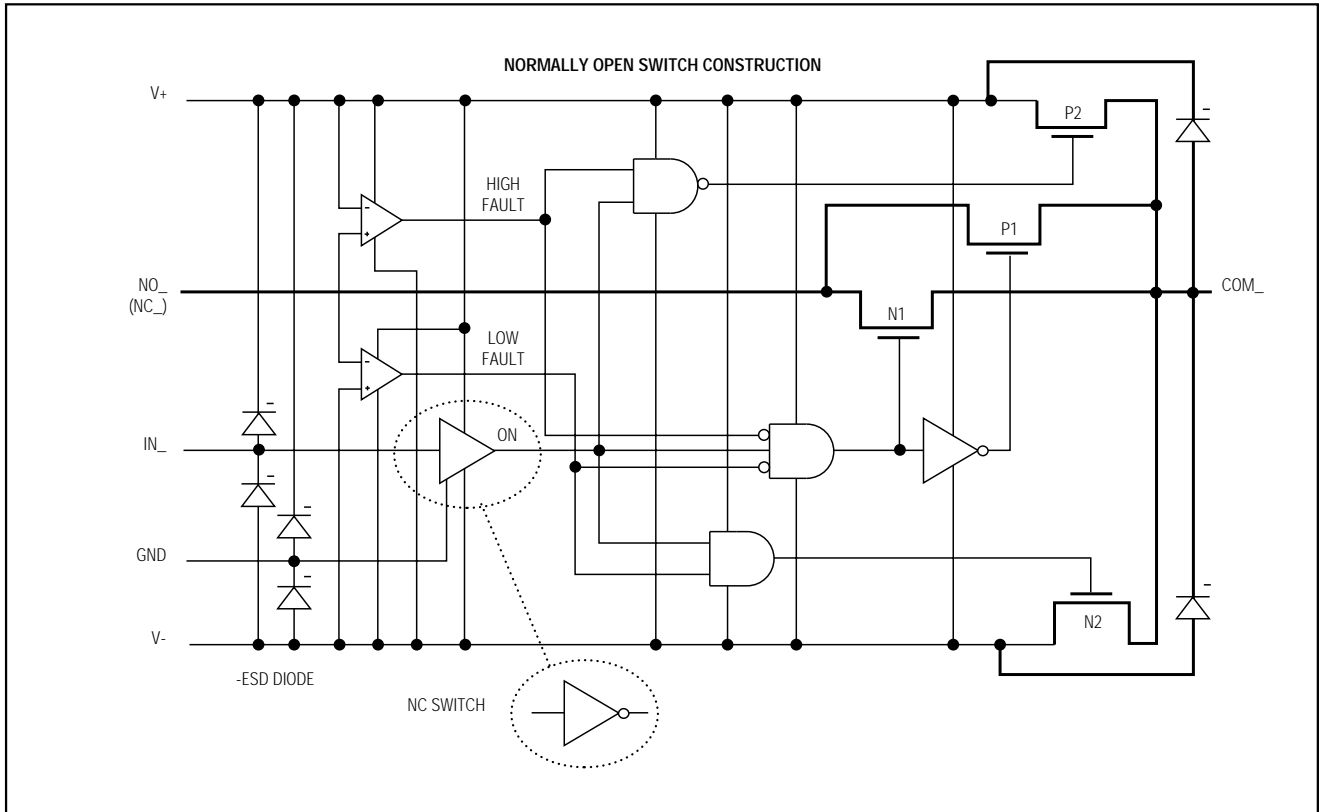

Figure 1. Block Diagram

**Overview of MAX4511/MAX4512/MAX4513**  
 The MAX4511/MAX4512/MAX4513 differ considerably from traditional fault-protection switches, with several advantages. First, they are constructed with two parallel FETs, allowing very low on-resistance when the switch is on. Second, they allow signals on the NC\_ or NO\_ pins that are within or slightly beyond the supply rails to be passed through the switch to the COM terminal, allowing rail-to-rail signal operation. Third, when a signal on NC\_ or NO\_ exceeds the supply rails by about 50mV (a fault condition), the voltage on COM\_ is limited to the appropriate polarity supply voltage. Operation is identical for both fault polarities. The fault-protection extends to  $\pm 36V$  from GND.

During a fault condition, the NO\_ or NC\_ input pin becomes high impedance regardless of the switch state or load resistance. If the switch is on, the COM\_ output current is furnished from the V+ or V- pin by “booster” FETs connected to each supply pin. These FETs can typically source or sink up to 10mA.

When power is removed, the fault protection is still in effect. In this case, the NO\_ or NC\_ terminals are a virtual open circuit. The fault can be up to  $\pm 40V$ .

The COM\_ pins are not fault protected; they act as normal CMOS switch pins. If a voltage source is connected to any COM\_ pin, it should be limited to the supply voltages. Exceeding the supply voltage will cause high currents to flow through the ESD protection diodes, possibly damaging the device (see *Absolute Maximum Ratings*).

### Pin Compatibility

These switches have identical pinouts to common non-fault-protected CMOS switches. Care should be exercised in considering them for direct replacements in existing printed circuit boards, however, since only the NO\_ and NC\_ pins of each switch are fault protected.

### Internal Construction

Internal construction is shown in Figure 1, with the analog signal paths shown in bold. A single normally open

# Quad, Rail-to-Rail, Fault-Protected, SPST Analog Switches

(NO) switch is shown; the normally closed (NC) configuration is identical except the logic-level translator becomes an inverter. The analog switch is formed by the parallel combination of N-channel FET N1 and P-channel FET P1, which are driven on and off simultaneously according to the input fault condition and the logic-level state.

## Normal Operation

Two comparators continuously compare the voltage on the NO<sub>-</sub> (or NC<sub>-</sub>) pin with V<sub>+</sub> and V<sub>-</sub>. When the signal on NO<sub>-</sub> or NC<sub>-</sub> is between V<sub>+</sub> and V<sub>-</sub> the switch acts normally, with FETs N1 and P1 turning on and off in response to IN<sub>-</sub> signals. The parallel combination of N1 and P1 forms a low-value resistor between NO<sub>-</sub> (or NC<sub>-</sub>) and COM<sub>-</sub> so that signals pass equally well in either direction.

## Positive Fault Condition

When the signal on NO<sub>-</sub> (or NC<sub>-</sub>) exceeds V<sub>+</sub> by about 50mV, the high-fault comparator output is high, turning off FETs N1 and P1. This makes the NO<sub>-</sub> (or NC<sub>-</sub>) pin high impedance regardless of the switch state. If the switch state is “off”, all FETs are turned off and both NO<sub>-</sub> (or NC<sub>-</sub>) and COM<sub>-</sub> are high impedance. If the switch state is “on”, FET P2 is turned on, sourcing current from V<sub>+</sub> to COM<sub>-</sub>.

## Negative Fault Condition

When the signal on NO<sub>-</sub> (or NC<sub>-</sub>) exceeds V<sub>-</sub> by about 50mV, the low-fault comparator output is high, turning off FETs N1 and P1. This makes the NO<sub>-</sub> (or NC<sub>-</sub>) pin high impedance regardless of the switch state. If the switch state is “off”, all FETs are turned off and both NO<sub>-</sub> (or NC<sub>-</sub>) and COM<sub>-</sub> are high impedance. If the switch state is “on”, FET N2 is turned on, sinking current from COM<sub>-</sub> to V<sub>-</sub>.

## Transient Fault Response and Recovery

When a fast rise-time and fall-time transient on IN<sub>-</sub> exceeds V<sub>+</sub> or V<sub>-</sub>, the output (COM<sub>-</sub>) follows the input (IN<sub>-</sub>) to the supply rail with only a few nanoseconds delay. This delay is due to the switch on-resistance and circuit capacitance to ground. When the input transient returns to within the supply rails, however, there is a longer output recovery time delay. For positive faults, the recovery time is typically 3.5μs. For negative faults, the recovery time is typically 1.3μs. These values depend on the COM<sub>-</sub> output resistance and capacitance, and are not production tested or guaranteed. The delays are not dependent on the fault amplitude. Higher COM<sub>-</sub> output resistance and capacitance increase recovery times.

## COM<sub>-</sub> and IN<sub>-</sub> Pins

FETs N2 and P2 can source about ±10mA from V<sub>+</sub> or V<sub>-</sub> to the COM<sub>-</sub> pin in the fault condition. Ensure that if the COM<sub>-</sub> pin is connected to a low-resistance load, the absolute maximum current rating of 30mA is never exceeded, both in normal and fault conditions.

The GND, COM<sub>-</sub>, and IN<sub>-</sub> pins do not have fault protection. Reverse ESD-protection diodes are internally connected between GND, COM<sub>-</sub>, IN<sub>-</sub> and both V<sub>+</sub> and V<sub>-</sub>. If a signal on GND, COM<sub>-</sub>, or IN<sub>-</sub> exceeds V<sub>+</sub> or V<sub>-</sub> by more than 300mV, one of these diodes will conduct heavily. During normal operation these reverse-biased ESD diodes leak a few nanoamps of current to V<sub>+</sub> and V<sub>-</sub>.

## Fault-Protection Voltage and Power Off

The maximum fault voltage on the NC<sub>-</sub> or NO<sub>-</sub> pins is ±36V with power applied and ±40V with power off.

## Failure Modes

The MAX4511/MAX4512/MAX4513 are not lightning arrestors or surge protectors.

Exceeding the fault-protection voltage limits on NO<sub>-</sub> or NC<sub>-</sub>, even for very short periods, can cause the device to fail. The failure modes may not be obvious, and failure in one switch may or may not affect other switches in the same package.

## Ground

There is no connection between the analog signal paths and GND. The analog signal paths consist of an N-channel and P-channel MOSFET with their sources and drains paralleled and their gates driven out of phase to V<sub>+</sub> and V<sub>-</sub> by the logic-level translators.

V<sub>+</sub> and GND power the internal logic and logic-level translators and set the input logic thresholds. The logic-level translators convert the logic levels to switched V<sub>+</sub> and V<sub>-</sub> signals to drive the gates of the analog switches. This drive signal is the only connection between the power supplies and the analog signals. GND, IN<sub>-</sub>, and COM<sub>-</sub> have ESD-protection diodes to V<sub>+</sub> and V<sub>-</sub>.

## IN<sub>-</sub> Logic-Level Thresholds

The logic-level thresholds are CMOS and TTL compatible when V<sub>+</sub> is +15V. As V<sub>+</sub> is raised the threshold increases slightly, and when V<sub>+</sub> reaches 25V the level threshold is about 2.8V—above the TTL output high level minimum of 2.4V, but still compatible with CMOS outputs (see *Typical Operating Characteristics*).

Increasing V<sub>-</sub> has no effect on the logic-level thresholds, but it does increase the gate-drive voltage to the signal FETs, reducing their on-resistance.

# Quad, Rail-to-Rail, Fault-Protected, SPST Analog Switches

## Bipolar Supplies

The MAX4511/MAX4512/MAX4513 operate with bipolar supplies between  $\pm 4.5V$  and  $\pm 18V$ . The  $V+$  and  $V-$  supplies need not be symmetrical, but their difference can not exceed the absolute maximum rating of 44V.

## Single Supply

The MAX4511/MAX4512/MAX4513 operate from a single supply between +9V and +36V when  $V-$  is connected to GND.

## High-Frequency Performance

In  $50\Omega$  systems, signal response is reasonably flat up to 50MHz (see *Typical Operating Characteristics*). Above

20MHz, the on-response has several minor peaks that are highly layout dependent. The problem with high-frequency operation is not turning the switch on, but turning it off. The off-state switch acts like a capacitor and passes higher frequencies with less attenuation. At 10MHz, off isolation is about -42dB in  $50\Omega$  systems, becoming worse (approximately 20dB per decade) as frequency increases. Higher circuit impedances also make off isolation worse. Adjacent channel attenuation is about 3dB above that of a bare IC socket and is due entirely to capacitive coupling.

## Test Circuits/Timing Diagrams

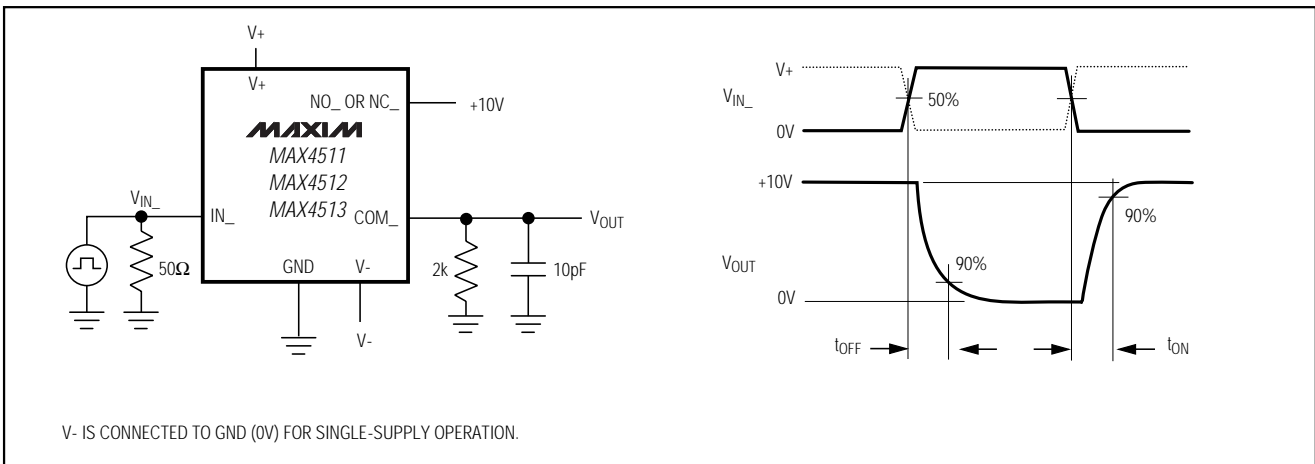

Figure 2. Switch Turn-On/Turn-Off Times

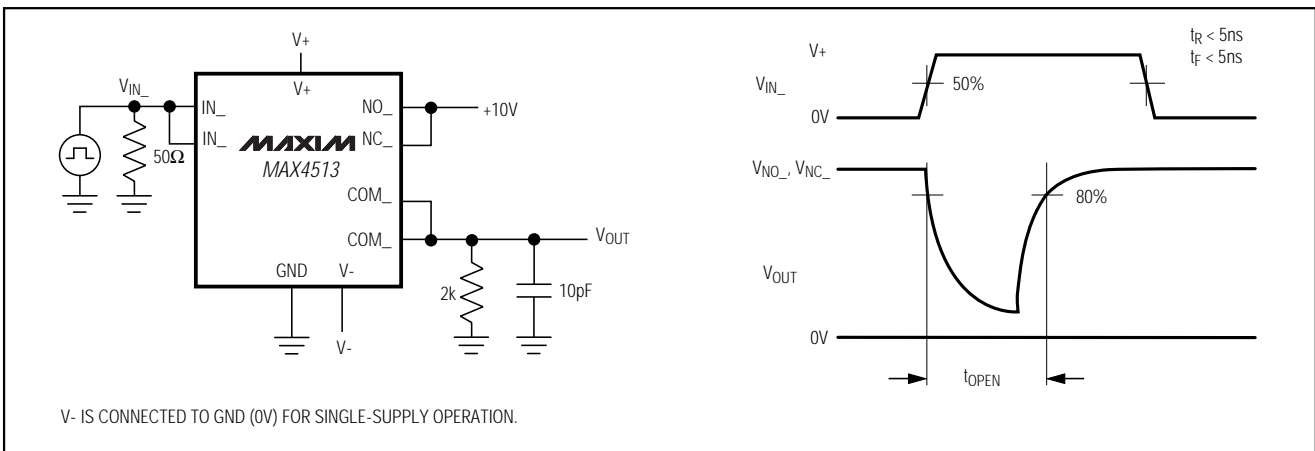

Figure 3. MAX4513 Break-Before-Make Interval

# Quad, Rail-to-Rail, Fault-Protected, SPST Analog Switches

## Test Circuits/Timing Diagrams (continued)

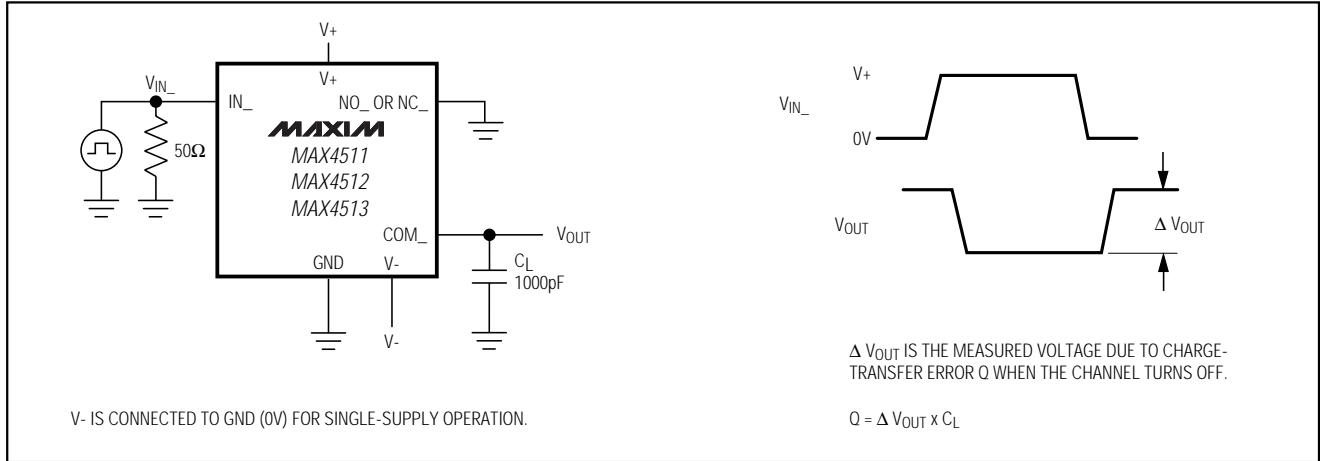

Figure 4. Charge Injection

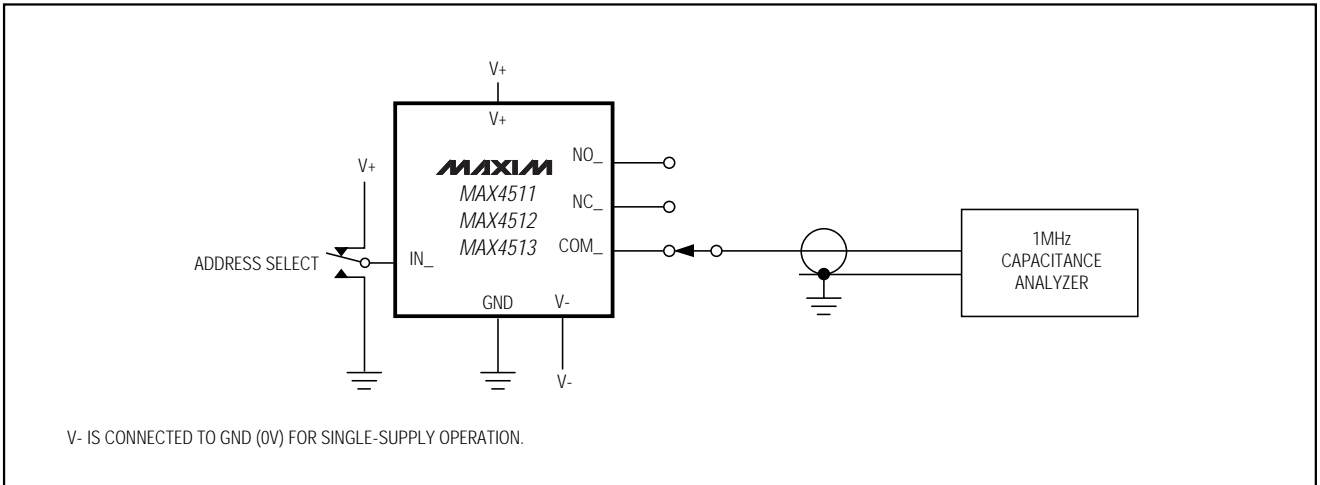

Figure 5. COM<sub>1</sub>, NO<sub>1</sub>, NC<sub>1</sub> Capacitance

# Quad, Rail-to-Rail, Fault-Protected, SPST Analog Switches

## Test Circuits/Timing Diagrams (continued)

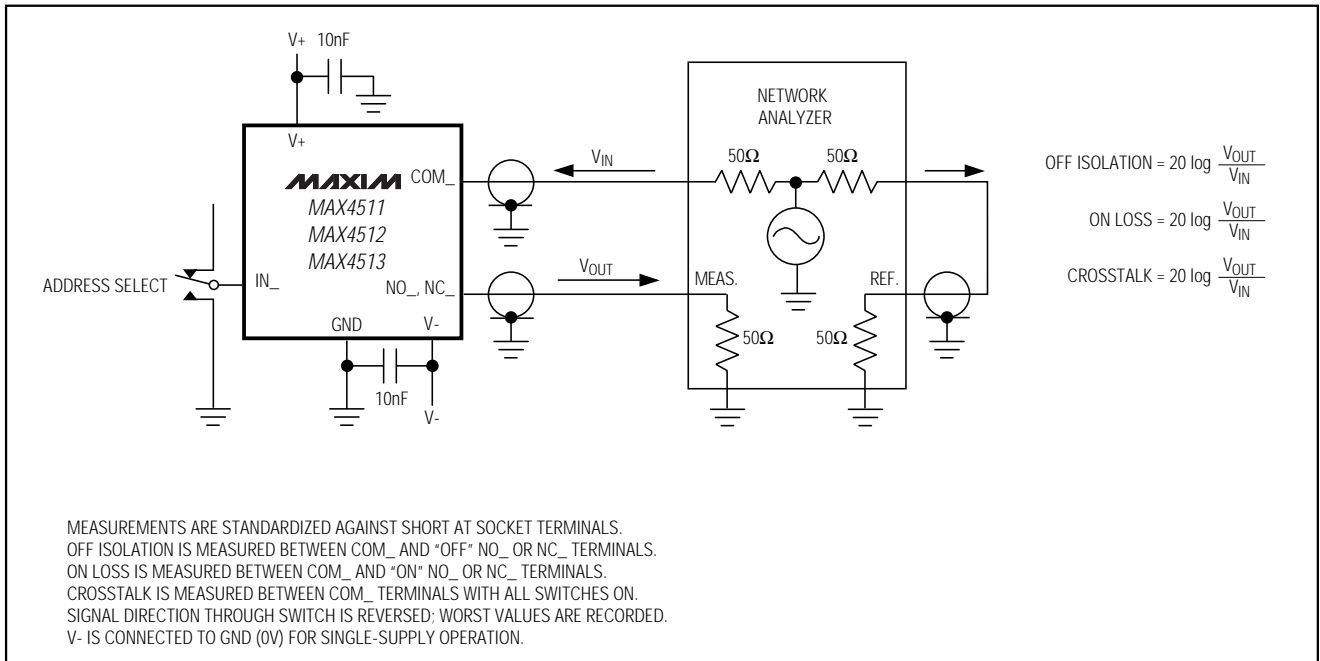
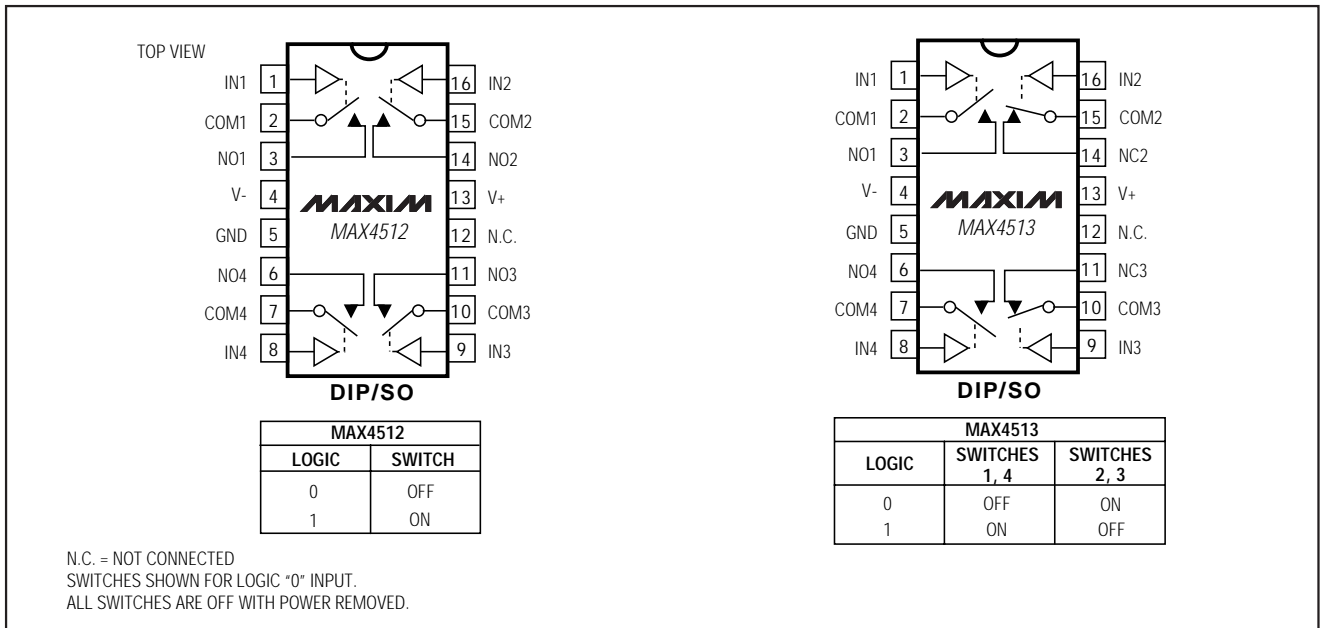

Figure 6. Frequency Response, Off Isolation, and Crosstalk

## Pin Configurations/Functional Diagrams/Truth Tables (continued)



MAX4511/MAX4512/MAX4513

# Quad, Rail-to-Rail, Fault-Protected, SPST Analog Switches

## Chip Topographies

## Ordering Information (continued)

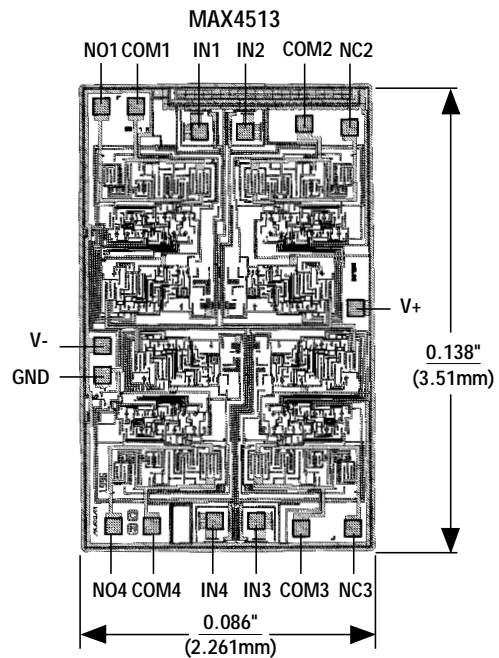
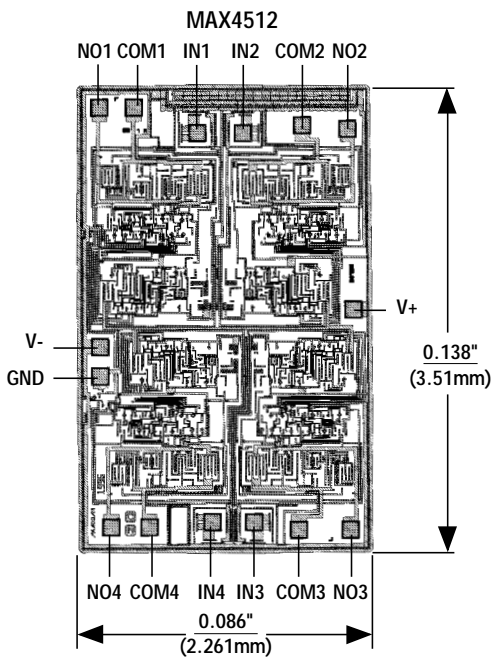
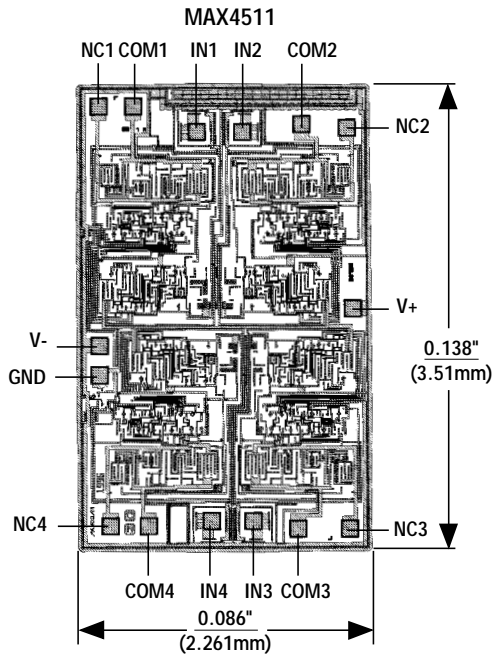

PART	TEMP. RANGE	PIN-PACKAGE
<b>MAX4512</b> CPE	0°C to +70°C	16 Plastic DIP
MAX4512CSE	0°C to +70°C	16 Narrow SO
MAX4512C/D	0°C to +70°C	Dice*
MAX4512EPE	-40°C to +85°C	16 Plastic DIP
MAX4512ESE	-40°C to +85°C	16 Narrow SO
MAX4512MJE	-55°C to +125°C	16 CERDIP
<b>MAX4513</b> CPE	0°C to +70°C	16 Plastic DIP
MAX4513CSE	0°C to +70°C	16 Narrow SO
MAX4513C/D	0°C to +70°C	Dice*
MAX4513EPE	-40°C to +85°C	16 Plastic DIP
MAX4513ESE	-40°C to +85°C	16 Narrow SO
MAX4513MJE	-55°C to +125°C	16 CERDIP

\* Contact factory for dice specifications.

TRANSISTOR COUNT: 139  
SUBSTRATE CONNECTED TO: V+

# Quad, Rail-to-Rail, Fault-Protected, SPST Analog Switches

## Package Information

MAX4511/MAX4512/MAX4513

INCHES		MILLIMETERS		
MIN	MAX	MIN	MAX	
A	0.053	0.069	1.35	1.75
A1	0.004	0.010	0.10	0.25
B	0.014	0.019	0.35	0.49
C	0.007	0.010	0.19	0.25
e	0.050		1.27	
E	0.150	0.157	3.80	4.00
H	0.228	0.244	5.80	6.20
h	0.010	0.020	0.25	0.50
L	0.016	0.050	0.40	1.27

INCHES		MILLIMETERS		N	MS012	
MIN	MAX	MIN	MAX			
D	0.189	0.197	4.80	5.00	8	A
D	0.337	0.344	8.55	8.75	14	B
D	0.386	0.394	9.80	10.00	16	C

NOTES:  
 1. D&E DO NOT INCLUDE MOLD FLASH  
 2. MOLD FLASH OR PROTRUSIONS NOT TO EXCEED .15mm (.006")  
 3. LEADS TO BE COPLANAR WITHIN .102mm (.004")  
 4. CONTROLLING DIMENSION: MILLIMETER  
 5. MEETS JEDEC MS012-XX AS SHOWN IN ABOVE TABLE  
 6. N = NUMBER OF PINS

MAXIM  
 PACKAGE FAMILY OUTLINE: SDCIP .150" 1/1 21-0041 A

INCHES		MILLIMETERS		
MIN	MAX	MIN	MAX	
A	---	0.200	---	5.08
A1	0.015	---	0.38	---
A2	0.125	0.175	3.18	4.45
A3	0.055	0.080	1.40	2.03
B	0.016	0.022	0.41	0.56
B1	0.045	0.065	1.14	1.65
C	0.008	0.012	0.20	0.30
D1	0.005	0.080	0.13	2.03
E	0.300	0.325	7.62	8.26
E1	0.240	0.310	6.10	7.87
e	0.100	---	2.54	---
eA	0.300	---	7.62	---
eB	---	0.400	---	10.16
L	0.115	0.150	2.92	3.81

INCHES		MILLIMETERS		N	MS001	
MIN	MAX	MIN	MAX			
D	0.348	0.390	8.84	9.91	8	AB
D	0.735	0.765	18.67	19.43	14	AC
D	0.745	0.765	18.92	19.43	16	AA
D	0.885	0.915	22.48	23.24	18	AD
D	1.015	1.045	25.78	26.54	20	AE
D	1.14	1.265	28.96	32.13	24	AF
D	1.360	1.380	34.54	35.05	28	*5

NOTES:  
 1. D&E DO NOT INCLUDE MOLD FLASH  
 2. MOLD FLASH OR PROTRUSIONS NOT TO EXCEED .15mm (.006")  
 3. CONTROLLING DIMENSION: MILLIMETER  
 4. MEETS JEDEC MS001-XX AS SHOWN IN ABOVE TABLE  
 5. SIMILAR TO JEDEC MO-058AB  
 6. N = NUMBER OF PINS

MAXIM  
 PACKAGE FAMILY OUTLINE: PDIP .300" 1/1 21-0043 A

# Quad, Rail-to-Rail, Fault-Protected, SPST Analog Switches

Package Information (continued)

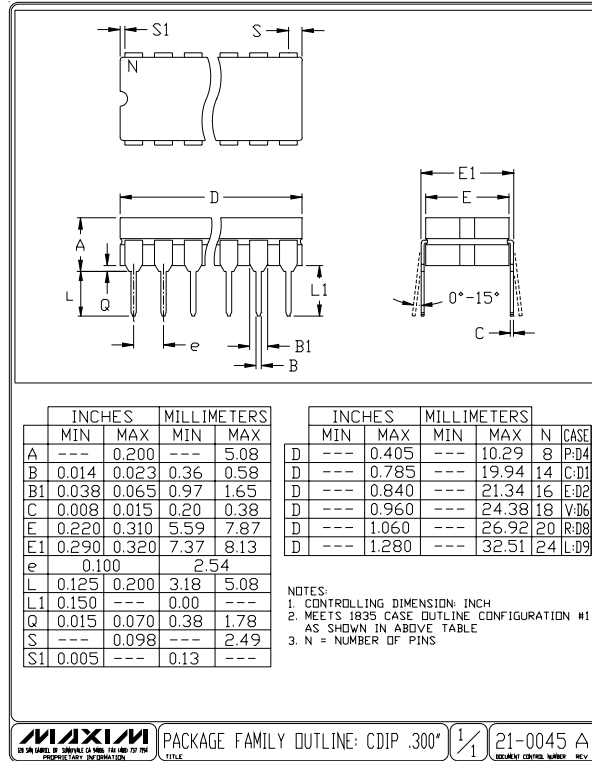

Maxim cannot assume responsibility for use of any circuitry other than circuitry entirely embodied in a Maxim product. No circuit patent licenses are implied. Maxim reserves the right to change the circuitry and specifications without notice at any time.

16 \_\_\_\_\_ Maxim Integrated Products, 120 San Gabriel Drive, Sunnyvale, CA 94086 408-737-7600