



# 10Ω, Quad, SPST, CMOS Analog Switches

MAX312/MAX313/MAX314

## General Description

Maxim's MAX312/MAX313/MAX314 analog switches feature low on-resistance (10Ω max) and 1.5Ω on-resistance matching between channels. These switches conduct equally well in either direction. They offer low leakage over temperature (2.5nA at +85°C). Low power consumption and ESD tolerance greater than 2000V per Method 3015.7 are guaranteed.

The MAX312/MAX313/MAX314 are quad, single-pole/single-throw (SPST) analog switches. The MAX312 is normally closed (NC), and the MAX313 is normally open (NO). The MAX314 has two NC switches and two NO switches. All three devices operate from a single supply of +4.5V to +30V or from dual supplies of ±4.5V to ±20V.

## Features

- ◆ Pin Compatible with DG411/DG412/DG413
- ◆ Low On-Resistance (6.5Ω typical)
- ◆ Guaranteed RON Match Between Channels (1.5Ω max)
- ◆ Guaranteed RON Flatness over Specified Signal Range (2Ω max)
- ◆ Guaranteed ESD Protection > 2000V per Method 3015.7
- ◆ Crosstalk > 96dB at 20kHz
- ◆ Single-Supply Operation: +4.5V to +30V  
Dual-Supply Operation: ±4.5V to ±20V
- ◆ Rail-to-Rail Signal Handling

## Applications

- Test Equipment
- Communication Systems
- PBX, PABX Systems
- Audio Signal Routing
- Avionics
- Sample-and-Hold Circuits
- Data Acquisition Systems

## Ordering Information

PART	TEMP. RANGE	PIN-PACKAGE
MAX312CPE	0°C to +70°C	16 Plastic DIP
MAX312CSE	0°C to +70°C	16 Narrow SO
MAX312CUE	0°C to +70°C	16 TSSOP
MAX312C/D	0°C to +70°C	Dice*
MAX312EPE	-40°C to +85°C	16 Plastic DIP
MAX312ESE	-40°C to +85°C	16 Narrow SO
MAX312EUE	-40°C to +85°C	16 TSSOP
MAX312MJE	-55°C to +125°C	16 CERDIP**

Ordering Information continued at end of data sheet.

\* Contact factory for dice specifications.

\*\*Contact factory for availability.

## Pin Configurations/Functional Diagrams/Truth Tables

TOP VIEW

DIP/SO/TSSOP

SO/MAX312	
LOGIC	SWITCH
0	ON
1	OFF

DIP/SO/TSSOP

MAX313	
LOGIC	SWITCH
0	OFF
1	ON

DIP/SO/TSSOP

MAX314		
LOGIC	SWITCHES 1,4	SWITCHES 2,3
0	OFF	ON
1	ON	OFF

SWITCHES SHOWN FOR LOGIC "0" INPUT



For free samples & the latest literature: <http://www.maxim-ic.com>, or phone 1-800-998-8800.  
For small orders, phone 1-800-835-8769.

# 10Ω, Quad, SPST, CMOS Analog Switches

## ABSOLUTE MAXIMUM RATINGS

Voltages Referenced to GND

V+ .....	-0.3V to +44V
V- .....	+0.3V to -44V
V+ to V- .....	-0.3V to +44V
VL .....	(GND - 0.3V) to (V+ + 0.3V)
All Other Pins (Note 1) .....	(V- - 2V) to (V+ + 2V) or 30mA (whichever occurs first)
Continuous Current (COM_, NO_, NC_) .....	±100mA
Peak Current (COM_, NO_, NC_) .....	±300mA

Continuous Power Dissipation (T<sub>A</sub> = +70°C)

Plastic DIP (derate 10.53mW/°C above +70°C) .....	.842mW
Narrow SO (derate 8.70mW/°C above +70°C) .....	.696mW
CERDIP (derate 10.00mW/°C above +70°C) .....	.800mW
TSSOP (derate 6.7mW/°C above +70°C) .....	.457mW
Operating Temperature Ranges	
MAX31_C_ .....	0°C to +70°C
MAX31_E_ .....	-40°C to +85°C
MAX31_M_ .....	-55°C to +125°C
Storage Temperature Range .....	-65°C to +150°C
Lead Temperature (soldering, 10sec) .....	+300°C

Stresses beyond those listed under "Absolute Maximum Ratings" may cause permanent damage to the device. These are stress ratings only, and functional operation of the device at these or any other conditions beyond those indicated in the operational sections of the specifications is not implied. Exposure to absolute maximum rating conditions for extended periods may affect device reliability.

**Note 1:** Signals on NC\_, NO\_, COM\_, or IN\_ exceeding V+ or V- will be clamped by internal diodes. Limit forward diode current to maximum current rating.

## ELECTRICAL CHARACTERISTICS—Dual Supplies

(V+ = 15V, V- = -15V, VL = 5V, GND = 0V, V<sub>INH</sub> = 2.4V, V<sub>INL</sub> = 0.8V, T<sub>A</sub> = T<sub>MIN</sub> to T<sub>MAX</sub>, unless otherwise noted.)

PARAMETER	SYMBOL	CONDITIONS		MIN	TYP (Note 2)	MAX	UNITS	
<b>ANALOG SWITCH</b>								
Analog Signal Range	V <sub>COM_</sub> , V <sub>NO_</sub> , V <sub>NC_</sub>	(Note 3)		V-		V+	V	
On-Resistance	R <sub>ON</sub>	I <sub>COM</sub> = 10mA, V <sub>NO_</sub> or V <sub>NC_</sub> = ±10V	T <sub>A</sub> = +25°C	C, E	6.5	10	Ω	
				M		9		
			T <sub>A</sub> = T <sub>MIN</sub> to T <sub>MAX</sub>			15		
On-Resistance Match Between Channels (Note 4)	ΔR <sub>ON</sub>	I <sub>COM</sub> = 10mA, V <sub>NO_</sub> or V <sub>NC_</sub> = ±10V	T <sub>A</sub> = +25°C		0.3	1.5	Ω	
			T <sub>A</sub> = T <sub>MIN</sub> to T <sub>MAX</sub>			3		
On-Resistance Flatness (Note 5)	R <sub>FLAT(ON)</sub>	I <sub>COM</sub> = 10mA, V <sub>NO_</sub> or V <sub>NC_</sub> = -5V, 0V, 5V	T <sub>A</sub> = +25°C		0.2	2	Ω	
			T <sub>A</sub> = T <sub>MIN</sub> to T <sub>MAX</sub>			4		
Off Leakage Current (NO_ or NC_) (Note 6)	I <sub>NO</sub> I <sub>NC</sub>	V <sub>COM</sub> = ∓10V, V <sub>NO_</sub> or V <sub>NC_</sub> = ±10V	T <sub>A</sub> = +25°C		-0.5	-0.02	0.5	nA
			T <sub>A</sub> = T <sub>MIN</sub> to T <sub>MAX</sub>	C, E	-2.5		2.5	
				M	-40		40	
COM Off Leakage Current (Note 6)	I <sub>NC(OFF)</sub>	V <sub>COM</sub> = ±10V, V <sub>NO_</sub> or V <sub>NC_</sub> = ∓10V	T <sub>A</sub> = +25°C		-0.5	-0.02	0.5	nA
			T <sub>A</sub> = T <sub>MIN</sub> to T <sub>MAX</sub>	C, E	-2.5		2.5	
				M	-40		40	
COM On Leakage Current (Note 6)	I <sub>COM(ON)</sub>	V <sub>COM</sub> = ±10V, V <sub>NO_</sub> or V <sub>NC_</sub> = ±10V	T <sub>A</sub> = +25°C		-1	-0.04	1	nA
			T <sub>A</sub> = T <sub>MIN</sub> to T <sub>MAX</sub>	C, E	-5		5	
				M	-100		100	

# 10Ω, Quad, SPST, CMOS Analog Switches

MAX312/MAX313/MAX314

## ELECTRICAL CHARACTERISTICS—Dual Supplies (continued)

(V+ = 15V, V- = -15V, VL = 5V, GND = 0V, VINH = 2.4V, VINL = 0.8V, TA = TMIN to TMAX, unless otherwise noted.)

PARAMETER	SYMBOL	CONDITIONS	MIN	TYP (Note 2)	MAX	UNITS	
<b>LOGIC INPUT</b>							
Input Current with Input Voltage High	I <sub>INH</sub>	IN <sub>-</sub> = 2.4V, all others = 0.8V	-0.500	0.005	0.500	μA	
Input Current with Input Voltage Low	I <sub>INL</sub>	IN <sub>-</sub> = 0.8V, all others = 2.4V	-0.500	0.005	0.500	μA	
<b>POWER SUPPLY</b>							
Power-Supply Range			±4.5		±20.0	V	
Positive Supply Current	I <sub>+</sub>	All channels on or off, V <sub>IN</sub> = 0V or 5V, V <sub>+</sub> = 16.5V V <sub>-</sub> = -16.5V	TA = +25°C	-1	0.0001	1	μA
			TA = T <sub>MIN</sub> to T <sub>MAX</sub>	-5		5	
Negative Supply Current	I <sub>-</sub>	All channels on or off, V <sub>IN</sub> = 0V or 5V, V <sub>+</sub> = 16.5V V <sub>-</sub> = -16.5V	TA = +25°C	-1	0.0001	1	μA
			TA = T <sub>MIN</sub> to T <sub>MAX</sub>	-5		5	
Logic Supply Current	I <sub>L</sub>	All channels on or off, V <sub>IN</sub> = 0V or 5V, V <sub>+</sub> = 16.5V V <sub>-</sub> = -16.5V	TA = +25°C	-1	0.0001	1	μA
			TA = T <sub>MIN</sub> to T <sub>MAX</sub>	-5		5	
Ground Current	I <sub>GND</sub>	All channels on or off, V <sub>IN</sub> = 0V or 5V, V <sub>+</sub> = 16.5V V <sub>-</sub> = -16.5V	TA = +25°C	-1	-0.0001	1	μA
			TA = T <sub>MIN</sub> to T <sub>MAX</sub>	-5		5	
<b>DYNAMIC</b>							
Turn-On Time	t <sub>ON</sub>	Figure 2, V <sub>COM</sub> = ±10V	TA = +25°C	70	225	ns	
			TA = T <sub>MIN</sub> to T <sub>MAX</sub>				275
Turn-Off Time	t <sub>OFF</sub>	Figure 2, V <sub>COM</sub> = ±10V	TA = +25°C	65	185	ns	
			TA = T <sub>MIN</sub> to T <sub>MAX</sub>				235
Break-Before-Make Time Delay	t <sub>D</sub>	MAX314 only, Figure 3, R <sub>L</sub> = 300Ω, C <sub>L</sub> = 35pF	TA = +25°C	1	5	ns	
Charge Injection (Note 3)	V <sub>CTE</sub>	C <sub>L</sub> = 1.0nF V <sub>GEN</sub> = 0V, R <sub>GEN</sub> = 0Ω, Figure 4	TA = +25°C	-30	20	30	pC
Off Isolation (Note 7)	V <sub>ISO</sub>	R <sub>L</sub> = 50Ω, C <sub>L</sub> = 5pF, f = 1MHz, Figure 5	TA = +25°C		-65		dB
Crosstalk (Note 8)	V <sub>CT</sub>	R <sub>L</sub> = 50Ω, C <sub>L</sub> = 5pF, f = 1MHz, Figure 6	TA = +25°C		-85		dB
NC or NO Capacitance	C <sub>(OFF)</sub>	f = 1MHz, Figure 7	TA = +25°C		15		pF
COM Off Capacitance	C <sub>(COM)</sub>	f = 1MHz, Figure 7	TA = +25°C		15		pF
On Capacitance	C <sub>(COM)</sub>	f = 1MHz, Figure 7	TA = +25°C		47		pF

# 10Ω, Quad, SPST, CMOS Analog Switches

## ELECTRICAL CHARACTERISTICS—Single Supply

(V+ = 12V, V- = 0V, VL = 5V, GND = 0V, VINH = 2.4V, VINL = 0.8V, TA = TMIN to TMAX, unless otherwise noted.)

PARAMETER	SYMBOL	CONDITIONS		MIN	TYP (Note 2)	MAX	UNITS
<b>ANALOG SWITCH</b>							
Analog Signal Range	VCOM <sub>-</sub> , VNO <sub>-</sub> , VNC <sub>-</sub>	(Note 3)		0		V+	V
Channel On-Resistance	RON	ICOM = 10mA, VNC <sub>-</sub> or VNO <sub>-</sub> + 10V	TA = +25°C	12.5	25		Ω
			TA = TMIN to TMAX		35		
<b>POWER SUPPLY</b>							
Positive Supply Current	I+	V+ = 13.2V all channels on or off, VIN = 0V or 5V	TA = +25°C	-1	0.0001	1	μA
			TA = TMAX	-5		5	
Logic Supply Current	IL	VL = 5.5V all channels on or off, VIN = 0V or 5V	TA = +25°C	-1	0.0001	1	μA
			TA = TMAX	-5		5	
Ground Current	IGND	VL = 5.5V all channels on or off, VIN = 0V or 5V	TA = +25°C	-1	-0.0001	1	μA
			TA = TMAX	-5		5	
<b>DYNAMIC</b>							
Turn-On Time (Note 3)	tON	Figure 2, VNO <sub>-</sub> or VNC <sub>-</sub> = 8V	TA = +25°C	100	325		ns
			TA = TMIN to TMAX		425		
Turn-Off Time (Note 3)	tOFF	Figure 2, VNO <sub>-</sub> or VNC <sub>-</sub> = 8V	TA = +25°C	95	175		ns
			TA = TMIN to TMAX		225		
Break-Before-Make Time Delay (Note 3)	tD	MAX314 only, Figure 3 RL = 300Ω, CL = 35pF	TA = +25°C	5			ns
Charge Injection (Note 3)	VCTE	Figure 4, CL = 1.0nF, VGEN = 0V, RGEN = 0V	TA = +25°C		-5		pC

**Note 2:** The algebraic convention, where the most negative value is a minimum and the most positive value a maximum, is used in this data sheet.

**Note 3:** Guaranteed by design.

**Note 4:**  $\Delta R_{ON} = \Delta R_{ON \text{ max}} - \Delta R_{ON \text{ min}}$ .

**Note 5:** Flatness is defined as the difference between the maximum and minimum value of on-resistance as measured over the specified analog signal range.

**Note 6:** Leakage parameters are 100% tested at maximum-rated hot temperature and guaranteed by correlation at +25°C.

**Note 7:** Off isolation =  $20 \log_{10} [V_{COM} / (V_{NC} \text{ or } V_{NO})]$ , VCOM = output, VNC or VNO = input to off switch.

**Note 8:** Between any two switches.

**Note 9:** Leakage testing at single supply is guaranteed by testing with dual supplies.

# 10Ω, Quad, SPST, CMOS Analog Switches

## Typical Operating Characteristics

( $T_A = +25^\circ\text{C}$ , unless otherwise noted.)

MAX312/MAX313/MAX314

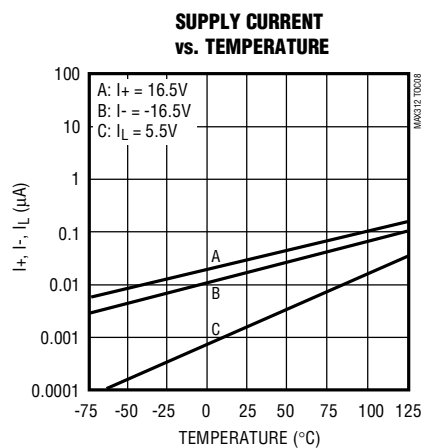
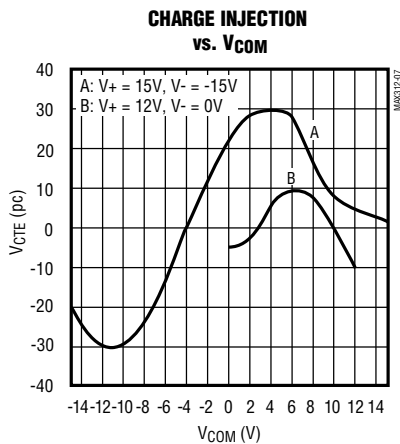
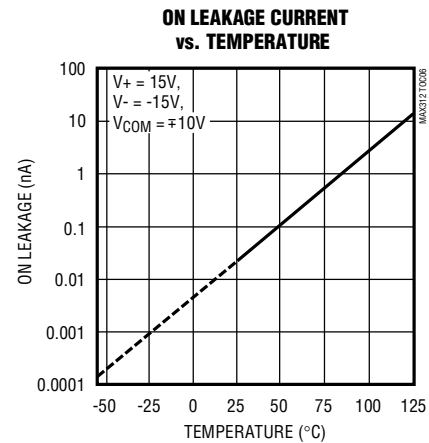
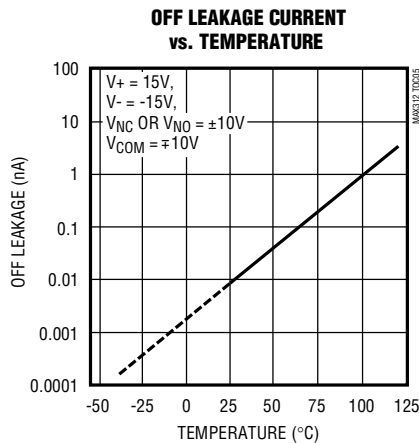
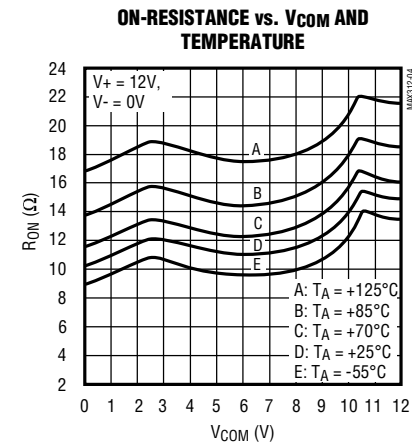
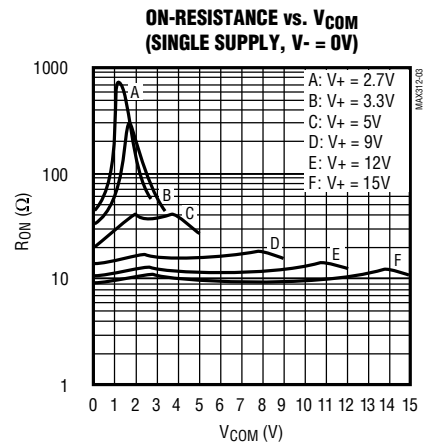
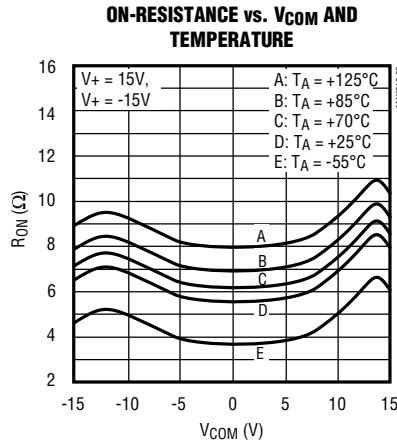
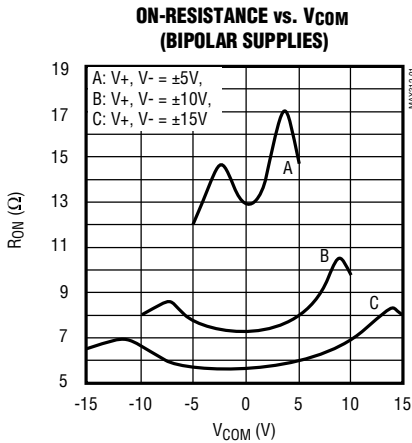

# 10Ω, Quad, SPST, CMOS Analog Switches

## Typical Operating Characteristics (continued)

(T<sub>A</sub> = +25°C, unless otherwise noted.)

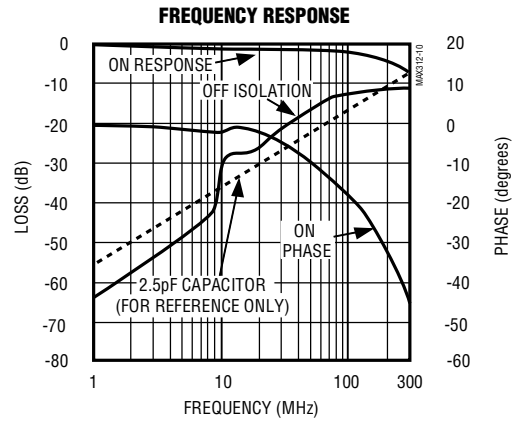
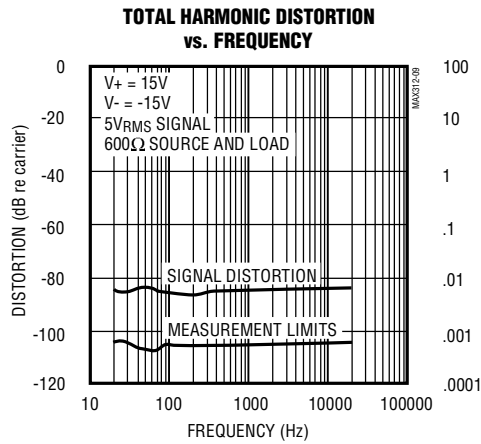

## Pin Description

PIN			NAME	FUNCTION
MAX312	MAX313	MAX314		
1, 8, 9, 16	1, 8, 9, 16	1, 8, 9, 16	IN2, IN4, IN3, IN2	Logic Level Inputs
2, 7, 10, 15	2, 7, 10, 15	2, 7, 10, 15	COM1, COM4, COM3, COM2	Analog Signal Common Terminals
3, 6, 11, 14	—	—	NC1, NC4, NC3, NC2	Analog Signal Normally Closed Terminals
—	3, 6, 11, 14	—	NO1, NO4, NO3, NO2	Analog Signal Normally Open Terminals
—	—	3, 6	NO1, NO4	Analog Signal Normally Open Terminals
—	—	11, 14	NC3, NC2	Analog Signal Normally Closed Terminals
4	4	4	V-	Negative Analog Supply Input (connect to GND for single-supply operation)
5	5	5	GND	Logic Level Ground
12	12	12	VL	Logic Supply Voltage
13	13	13	V+	Positive Analog Supply Input

# 10Ω, Quad, SPST, CMOS Analog Switches

## Applications Information

### Low-Distortion Audio

The MAX312/MAX313/MAX314, having very low  $R_{ON}$  and very low  $R_{ON}$  variation with signal amplitude, are well suited for low-distortion audio applications. The *Typical Operating Characteristics* show Total Harmonic Distortion (THD) vs. Frequency graphs for several signal amplitudes and impedances. Higher source and load impedances improve THD, but reduce off isolation.

### Off Isolation at High Frequencies

In 50Ω systems, the high-frequency on-response of these parts extends from DC to above 100MHz with a typical loss of -2dB. When the switch is turned off, however, it behaves like a capacitor, and off isolation decreases with increasing frequency. (Above 300MHz, the switch actually passes more signal turned off than turned on.) This effect is more pronounced with higher source and load impedances.

Above 5MHz, circuit board layout becomes critical, and it becomes difficult to characterize the response of the switch independent of the circuit. The graphs shown in the *Typical Operating Characteristics* were taken using a 50Ω source and load connected with BNC connec-

tors to a circuit board deemed "average"; that is, designed with isolation in mind, but not using strip-line or other special RF circuit techniques. For critical applications above 5MHz, use the MAX440, MAX441, and MAX442, which are fully characterized up to 160MHz.

MAX312/MAX313/MAX314

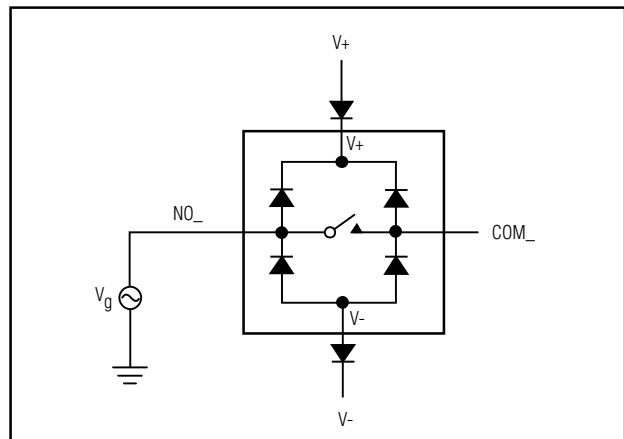

Figure 1. Overvoltage Protection Using External Blocking Diodes

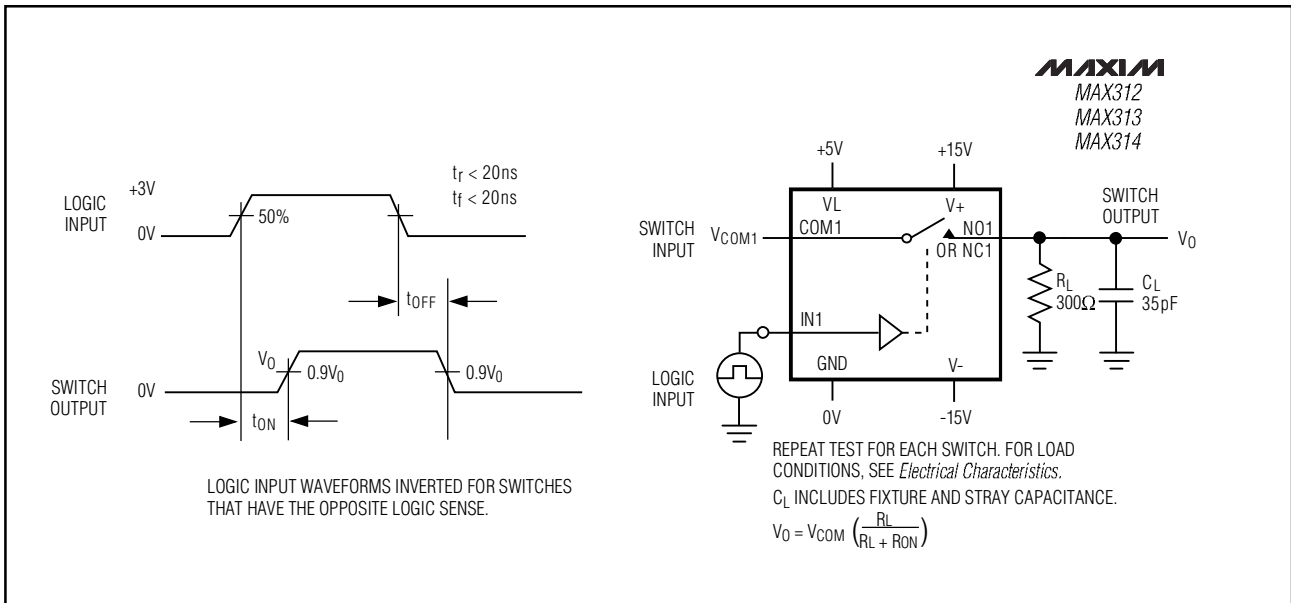

Figure 2. Switching-Time Test Circuit

# 10Ω, Quad, SPST, CMOS Analog Switches

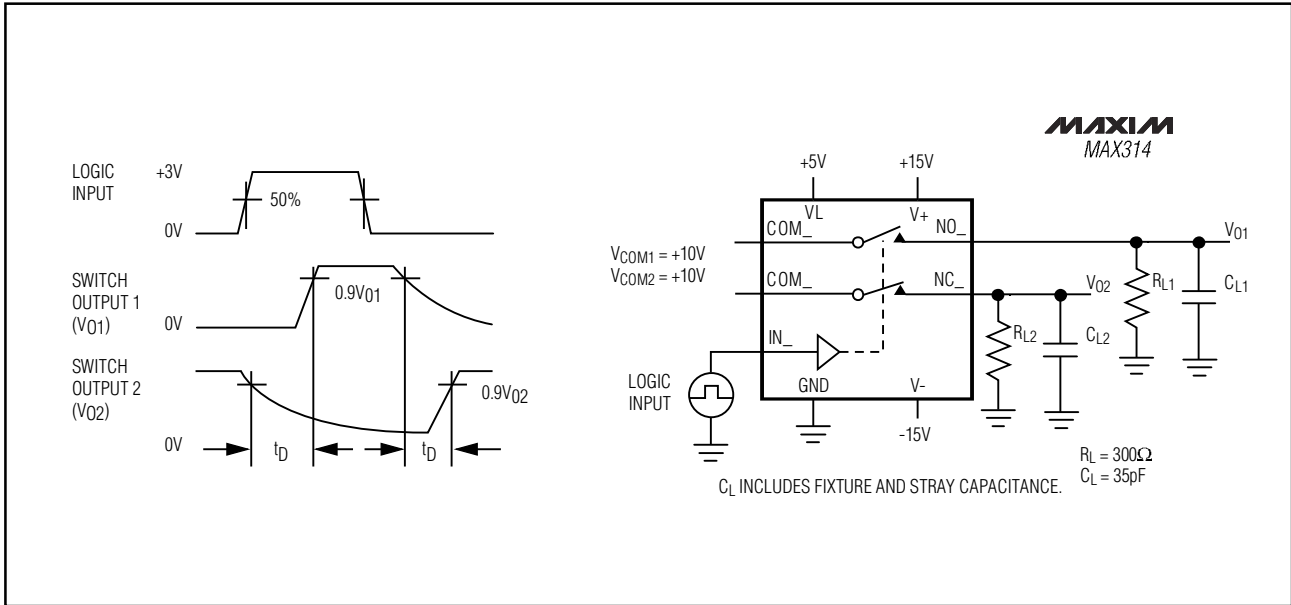

Figure 3. Break-Before-Make Test Circuit (MAX314 only)

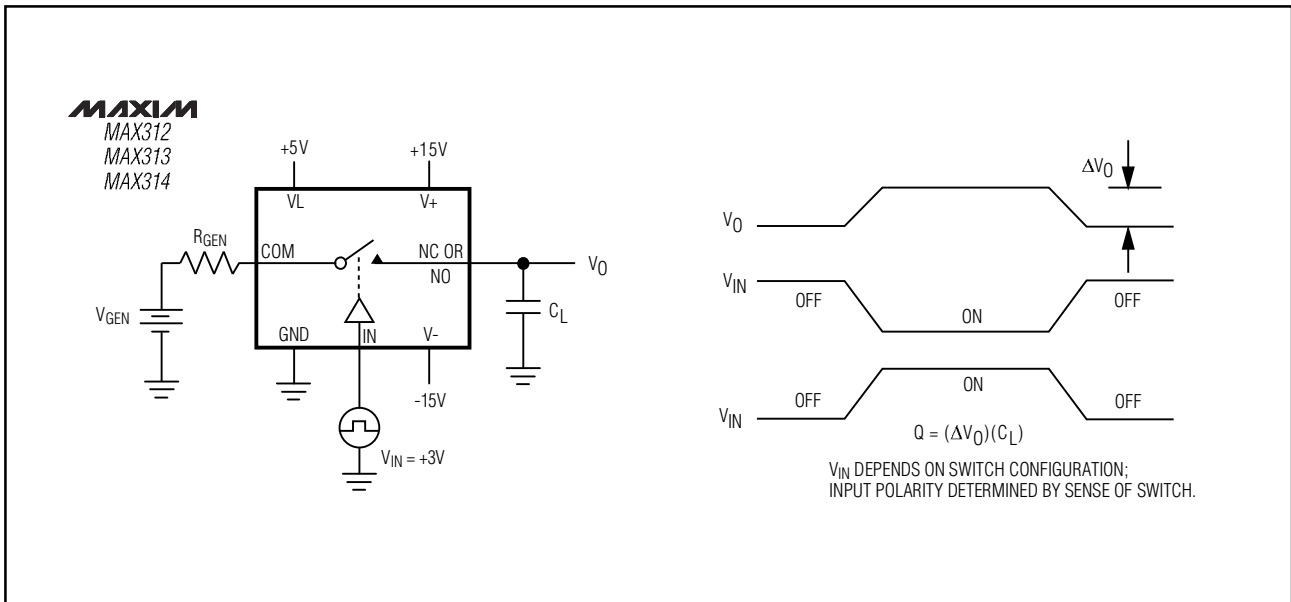

Figure 4. Charge Injection Test Circuit



# 10Ω, Quad, SPST, CMOS Analog Switches

MAX312/MAX313/MAX314

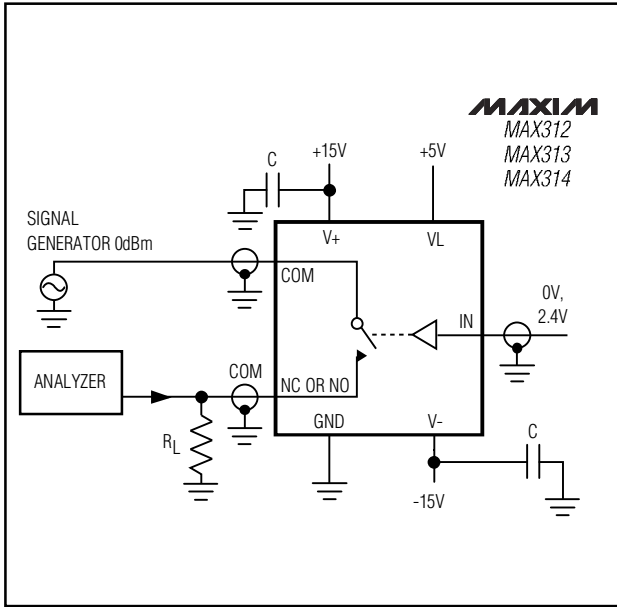

Figure 5. Off-Isolation Test Circuit

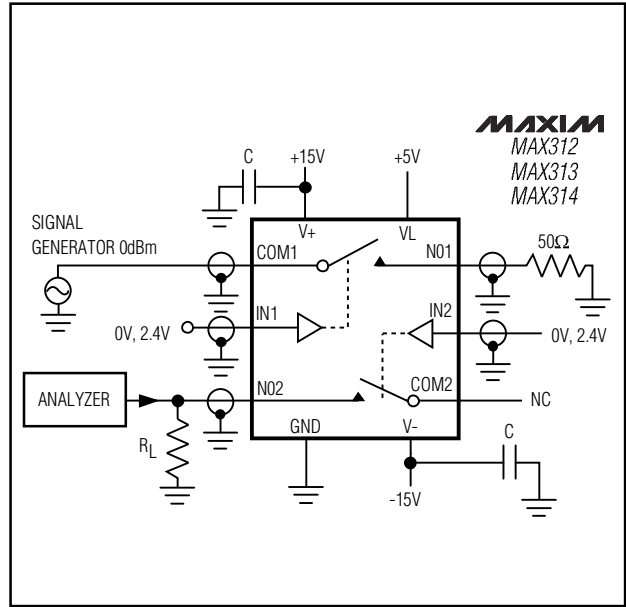

Figure 6. Crosstalk Test Circuit

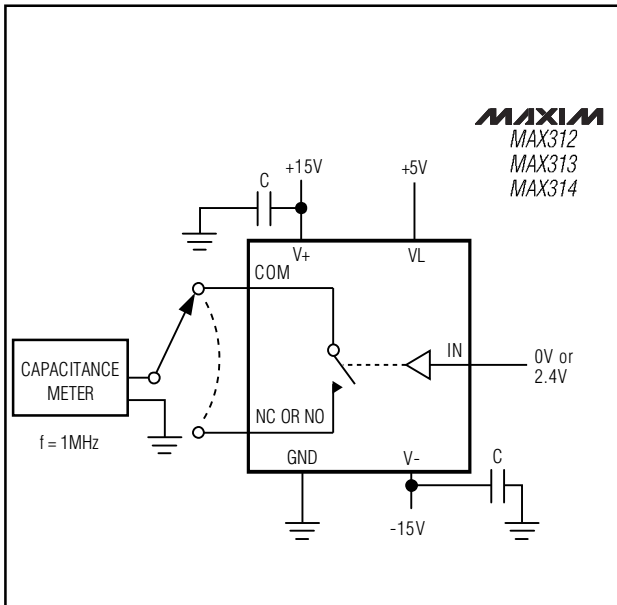

Figure 7. Channel-Off Capacitance Test Circuit

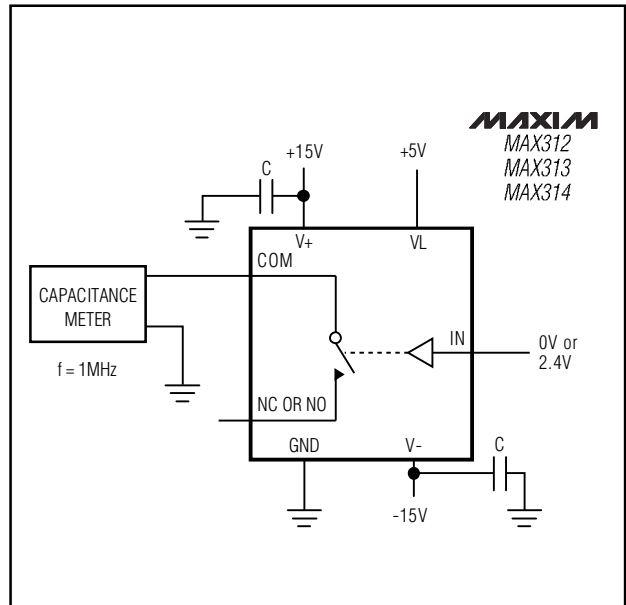

Figure 8. Channel-On Capacitance Test Circuit

# 10Ω, Quad, SPST, CMOS Analog Switches

## Ordering Information (continued)

PART	TEMP. RANGE	PIN-PACKAGE
<b>MAX313CPE</b>	0°C to +70°C	16 Plastic DIP
MAX313CSE	0°C to +70°C	16 Narrow SO
MAX313CUE	0°C to +70°C	16 TSSOP
MAX313C/D	0°C to +70°C	Dice*
MAX313EPE	-40°C to +85°C	16 Plastic DIP
MAX313ESE	-40°C to +85°C	16 Narrow SO
MAX313EUE	-40°C to +85°C	16 TSSOP
MAX313MJE	-55°C to +125°C	16 CERDIP**
<b>MAX314CPE</b>	0°C to +70°C	16 Plastic DIP
MAX314CSE	0°C to +70°C	16 Narrow SO
MAX314CUE	0°C to +70°C	16 TSSOP
MAX314C/D	0°C to +70°C	Dice*
MAX314EPE	-40°C to +85°C	16 Plastic DIP
MAX314ESE	-40°C to +85°C	16 Narrow SO
MAX314EUE	-40°C to +85°C	16 TSSOP
MAX314MJE	-55°C to +125°C	16 CERDIP**

\* Contact factory for dice specifications.

\*\*Contact factory for availability.

## Chip Topography

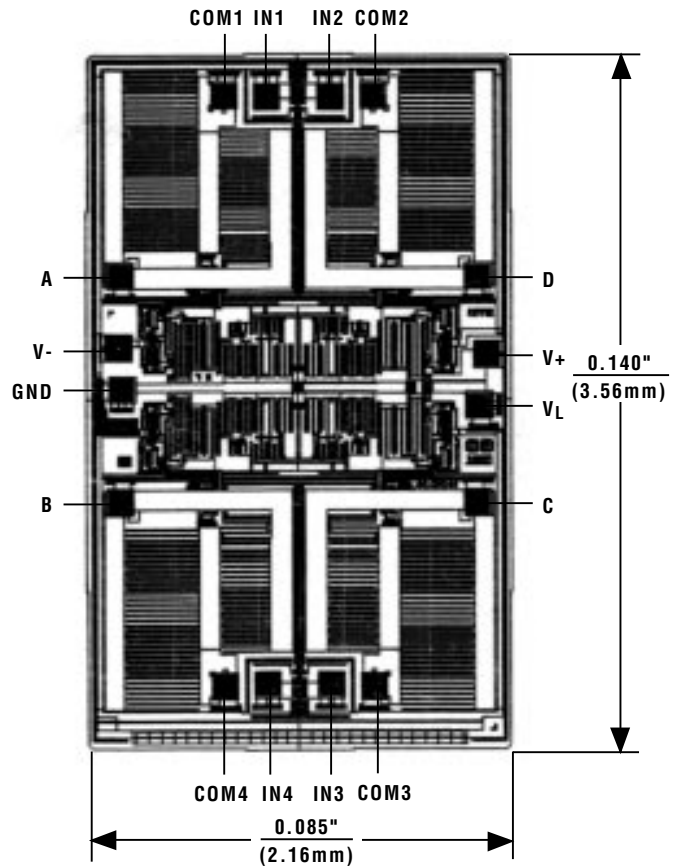

MAX312		MAX313		MAX314	
PIN	NAME	PIN	NAME	PIN	NAME
A	NC1	A	NO1	A	NC1
B	NC4	B	NO4	B	NC4
C	NC3	C	NO3	C	NC3
D	NC2	D	NO2	D	NC2

TRANSISTOR COUNT: 100

SUBSTRATE CONNECTED TO V+

# 10Ω, Quad, SPST, CMOS Analog Switches

## Package Information

MAX312/MAX313/MAX314

COMMON DIMENSIONS					
DIM.	MILLIMETERS		INCHES		
	MIN.	MAX.	MIN.	MAX.	
A	---	1.10	---	.043	
A <sub>1</sub>	0.05	0.15	.002	.006	
A <sub>2</sub>	0.85	0.95	.033	.037	
B	0.19	0.30	.007	.012	
B <sub>1</sub>	0.19	0.25	.007	.010	
C	0.090	0.20	.0035	.008	
C <sub>1</sub>	0.090	0.135	.0035	.0053	
D	SEE VARIATIONS	SEE VARIATIONS	SEE VARIATIONS	SEE VARIATIONS	
E	4.30	4.50	.169	.177	
e	0.65	BSC	.026	BSC	
H	6.25	6.50	.246	.256	
L	0.50	0.70	.020	.028	
N	SEE VARIATIONS	SEE VARIATIONS	SEE VARIATIONS	SEE VARIATIONS	
Y	2.85	3.15	.112	.124	
X	0°	8°	0°	8°	

JEDEC	MO-153	N	VARIATIONS					
			MILLIMETERS		INCHES			
			MIN.	MAX.	MIN.	MAX.		
		AB	14	D	4.90	5.10	.193	.201
		AC	16	D	4.90	5.10	.193	.201
		AC-EP	16	D	4.90	5.10	.193	.201
		AD	20	D	6.40	6.60	.252	.260
		AD-FP	20	D	6.40	6.60	.252	.260
		AE	24	D	7.70	7.90	.303	.311
		AF	28	D	9.60	9.80	.378	.386
		AF-EP	28	D	9.60	9.80	.378	.386
		X			5.35	5.65	.211	.222

**NOTES:**  
 1. DIMENSIONS D AND E DO NOT INCLUDE FLASH.  
 2. MOLD FLASH OR PROTRUSIONS NOT TO EXCEED .15 mm PER SIDE.  
 3. CONTROLLING DIMENSION: MILLIMETER.  
 4. MEETS JEDEC OUTLINE MO-153 VARIATIONS AB, AC, AD, AE, AF.  
 5. DIMENSIONS X AND Y APPLY TO EXPOSED PAD (EP) VERSIONS ONLY.  
 6. EXPOSED PAD FLUSH WITH BOTTOM OF PACKAGE WITHIN .002".

**MAXIM**  
 PROPRIETARY INFORMATION  
 TITLE: PACKAGE OUTLINE, TSSOP, 4.40mm BODY, 0.65mm PITCH  
 APPROVAL: DOCUMENT CONTROL NO: 21-0066 REV: C 1/1

INCHES				MILLIMETERS			
	MIN	MAX		MIN	MAX		
A	---	0.200	---	5.08			
A <sub>1</sub>	0.015	---	0.38	---			
A <sub>2</sub>	0.125	0.175	3.18	4.45			
A <sub>3</sub>	0.055	0.080	1.40	2.03			
B	0.016	0.022	0.41	0.56			
B <sub>1</sub>	0.045	0.065	1.14	1.65			
C	0.008	0.012	0.20	0.30			
D <sub>1</sub>	0.005	0.080	0.13	2.03			
E	0.300	0.325	7.62	8.26			
E <sub>1</sub>	0.240	0.310	6.10	7.87			
e	0.100	---	2.54	---			
eA	0.300	---	7.62	---			
eB	---	0.400	---	10.16			
L	0.115	0.150	2.92	3.81			

INCHES				MILLIMETERS			
	MIN	MAX		MIN	MAX	N	MS001
D	0.348	0.390	8.84	9.91	8	AB	
D	0.735	0.765	18.67	19.43	14	AC	
D	0.745	0.765	18.92	19.43	16	AA	
D	0.885	0.915	22.48	23.24	18	AD	
D	1.015	1.045	25.78	26.54	20	AE	
D	1.14	1.265	28.96	32.13	24	AF	
D	1.360	1.380	34.54	35.05	28	X5	

**NOTES:**  
 1. D & E DO NOT INCLUDE MOLD FLASH  
 2. MOLD FLASH OR PROTRUSIONS NOT TO EXCEED .15mm (.006")  
 3. CONTROLLING DIMENSION: MILLIMETER  
 4. MEETS JEDEC MS001-XX AS SHOWN IN ABOVE TABLE  
 5. SIMILAR TO JEDEC MO-058AB  
 6. N = NUMBER OF PINS

**MAXIM** PACKAGE FAMILY OUTLINE: PDIP .300" 1/1 21-0043 A  
IN THE MIDDLE OF THE TOP OF THE PACKAGE, SEE THE TOP VIEW.

# 10Ω, Quad, SPST, CMOS Analog Switches

## Package Information (continued)

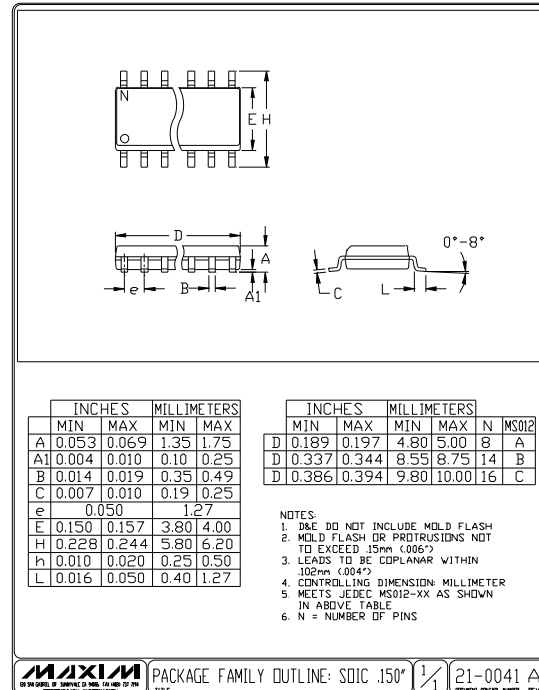
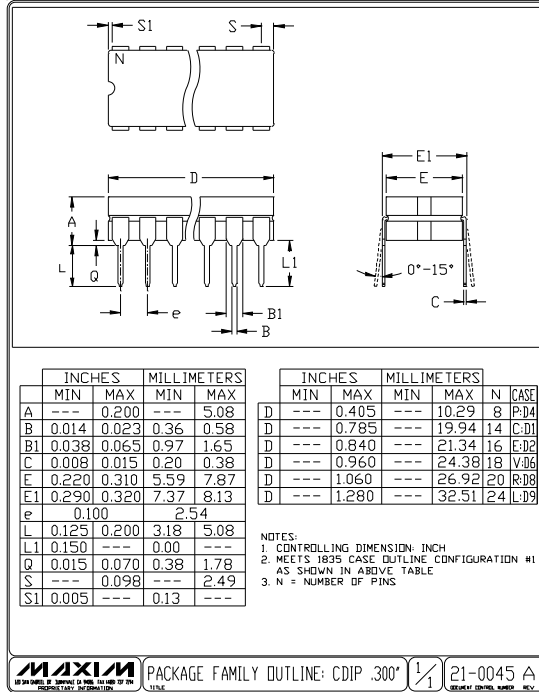

Maxim cannot assume responsibility for use of any circuitry other than circuitry entirely embodied in a Maxim product. No circuit patent licenses are implied. Maxim reserves the right to change the circuitry and specifications without notice at any time.

12 **Maxim Integrated Products, 120 San Gabriel Drive, Sunnyvale, CA 94086 408-737-7600**