

MN662741RH

Signal Processing LSI for CD Players

■ Overview

The MN662741RH is a CD signal processing LSI that, on a single chip, combines an optics servo for the CD player (focus, tracking, and traverse servos), digital signal processing (EFM demodulation and error correction), digital servo processing for the spindle motor, digital filter, and D/A converter, so thus covers all signal processing functions from the head's RF amplifier onward.

■ Features

(Optics servo)

- Focus, tracking, and traverse servos
- Automatic adjustment functions for FO/TR gain, FO/TR offset, and FO/TR balance
- Built-in D/A converter for drive voltage output
- Built-in dropout countermeasures
- Anti-shock functions
- Built-in track cross counter
- Support for both linear motor and screw-based traverse mechanisms
- Support for 3-and 1-beam systems

(Digital signal processing)

- Built-in DSL and PLL
- Frame synchronization detection, holding, and insertion
- Subcode data processing
 - Q data CRC check
 - Built-in Q data register
- CIRC error detection and correction
 - C1 decoder: duplex error correction
 - C2 decoder: triplex error correction
 - Built-in 16-K bits of RAM for use in de-interleaving
- Audio data interpolation
 - Four-sample average, hold of previous values
- Soft muting
- Digital attenuation (256 levels)
- Software attenuation (256 levels)
- Audio data peak level detection function
- Auto cue detection function
- Digital audio interface (EIAJ format)
- Audio data serial interface for input and output

(Spindle motor servo)

- CLV digital servo

(Audio circuits)

- Digital filter using 8-fold oversampling
- Built-in D/A converter (1-bit D/A converter)
- Built-in differential operational amplifier (2nd order low pass filter)

(Other)

- Built-in playback pitch control function ($\pm 13\%$)
- Operating voltage 4.0 to 5.5V

■ Applications

- CD Players

■ Block Diagram

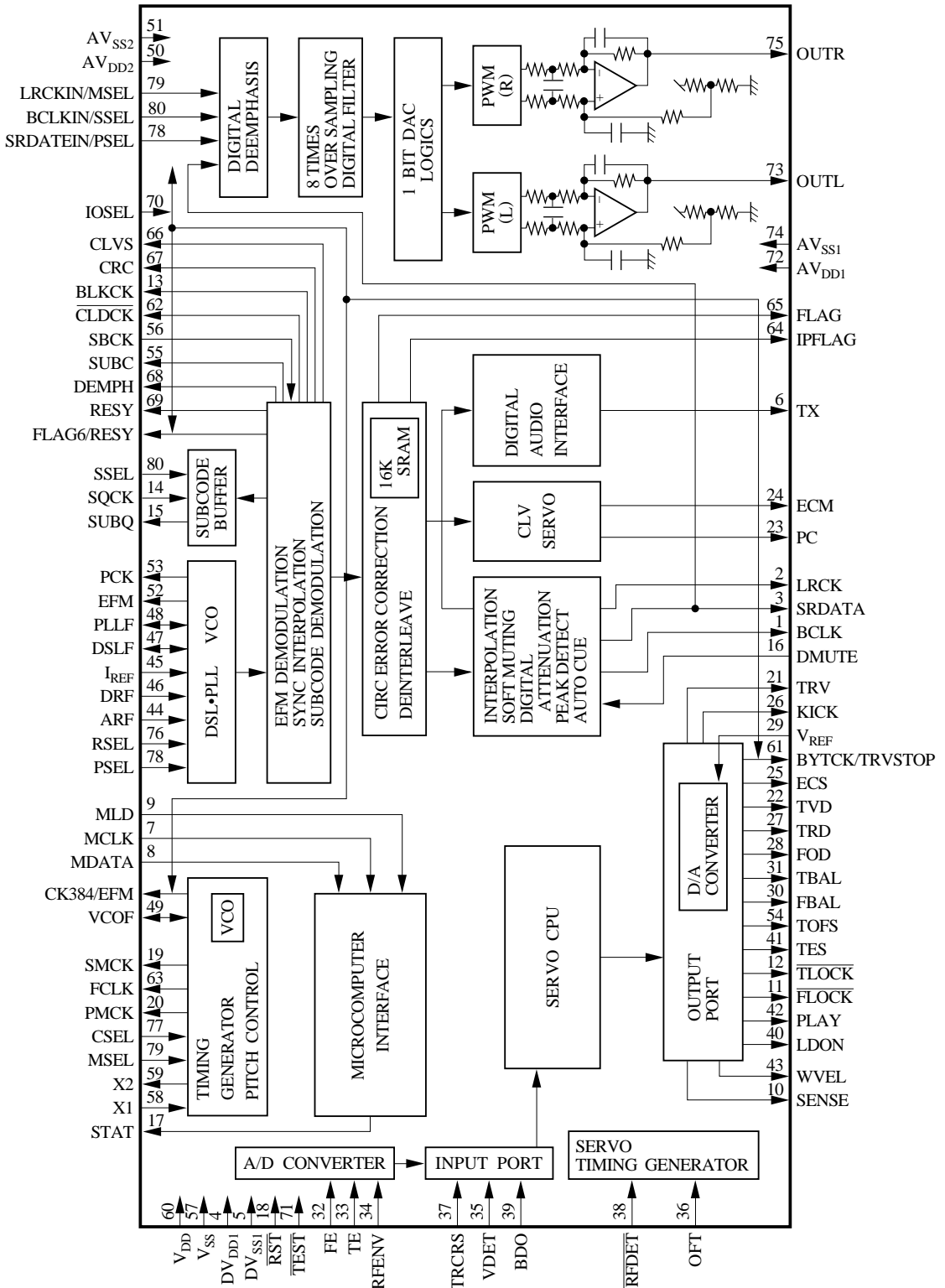

■ Package Dimensions (Unit: mm)

QFS080-P-1414

