

MM74HC174 Hex D-Type Flip-Flops with Clear

General Description

The MM74HC174 edge triggered flip-flops utilize advanced silicon-gate CMOS technology to implement D-type flip-flops. They possess high noise immunity, low power, and speeds comparable to low power Schottky TTL circuits. This device contains 6 master-slave flip-flops with a common clock and common clear. Data on the D input having the specified setup and hold times is transferred to the Q output on the LOW-to-HIGH transition of the CLOCK input. The CLEAR input when LOW, sets all outputs to a low state.

Each output can drive 10 low power Schottky TTL equivalent loads. The MM74HC174 is functionally as well as pin compatible to the 74LS174. All inputs are protected from damage due to static discharge by diodes to V_{CC} and ground.

Features

- Typical propagation delay: 16 ns
- Wide operating voltage range: 2–6V
- Low input current: 1 μ A maximum
- Low quiescent current: 80 μ A (74HC Series)
- Output drive: 10 LSTTL loads

Ordering Code:

Order Number	Package Number	Package Description
MM74HC174M	M16A	16-Lead Small Outline Integrated Circuit (SOIC), JEDEC MS-012, 0.150" Narrow
MM74HC174SJ	M16D	16-Lead Small Outline Package (SOP), EIAJ TYPE II, 5.3mm Wide
MM74HC174MTC	MTC16	16-Lead Thin Shrink Small Outline Package (TSSOP), JEDEC MO-153, 4.4mm Wide
MM74HC174N	N16E	16-Lead Plastic Dual-In-Line Package (PDIP), JEDEC MS-001, 0.300" Wide

Devices also available in Tape and Reel. Specify by appending the suffix letter "X" to the ordering code.

Connection Diagram

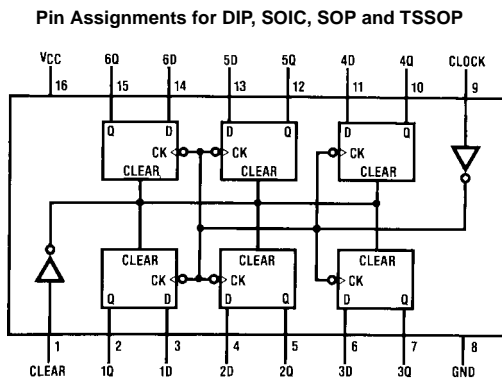

Truth Table

(Each Flip-Flop)

Inputs			Outputs
Clear	Clock	D	Q
L	X	X	L
H	↑	H	H
H	↑	L	L
H	L	X	Q_0

H = HIGH Level (steady state)
L = LOW Level (steady state)
X = Don't Care
↑ = Transition from LOW-to-HIGH level
 Q_0 = The level of Q before the indicated steady state input conditions were established.

Logic Diagram

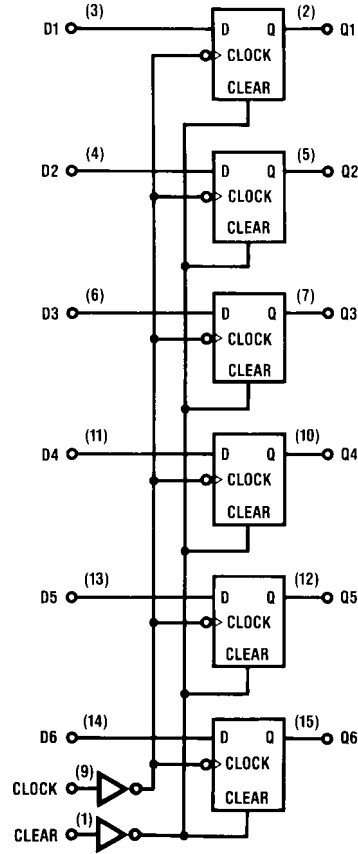

AC Electrical Characteristics						
$V_{CC} = 5V, T_A = 25^\circ C, C_L = 15pF, t_r = t_f = 6 ns$						
Symbol	Parameter	Conditions	Typ	Guaranteed Limit	Units	
f_{MAX}	Maximum Operating Frequency		50	30	MHz	
t_{PHL}, t_{PLH}	Maximum Propagation Delay, Clock or Clear to Output		16	30	ns	
t_{REM}	Minimum Removal Time, Clear to Clock		-2	5	ns	
t_S	Minimum Setup Time Data to Clock		10	20	ns	
t_H	Minimum Hold Time Clock to Data		0	5	ns	
t_W	Minimum Pulse Width Clock or Clear		10	16	ns	

AC Electrical Characteristics								
$C_L = 50 pF, t_r = t_f = 6 ns$ (unless otherwise specified)								
Symbol	Parameter	Conditions	V_{CC}	$T_A = 25^\circ C$			Units	
				Typ	Guaranteed Limits			
f_{MAX}	Maximum Operating Frequency		2.0V	5	4	3	MHz	
			4.5V	27	21	18	MHz	
			6.0V	31	24	20	MHz	
t_{PHL}, t_{PLH}	Maximum Propagation Delay Clock or Clear to Output		2.0V	55	165	206	248	ns
			4.5V	18	33	41	49	ns
			6.0V	16	28	35	42	ns
t_{REM}	Minimum Removal Time Clear to Clock		2.0V	1	5	5	5	ns
			4.5V	1	5	5	5	ns
			6.0V	1	5	5	5	ns
t_S	Minimum Setup Time Data to Clock		2.0V	42	100	125	150	ns
			4.5V	12	20	25	30	ns
			6.0V	10	17	21	25	ns
t_H	Minimum Hold Time Clock to Data		2.0V	1	5	5	5	ns
			4.5V	1	5	5	5	ns
			6.0V	1	5	5	5	ns
t_W	Minimum Pulse Width Clock or Clear		2.0V	35	80	106	120	ns
			4.5V	10	16	20	24	ns
			6.0V	8	14	18	20	ns
t_{TLH}, t_{THL}	Maximum Output Rise and Fall Time		2.0V	30	75	95	110	ns
			4.5V	8	15	19	22	ns
			6.0V	7	13	16	19	ns
t_r, t_f	Maximum Input Rise and Fall Time		2.0V		1000	1000	1000	ns
			4.5V		500	500	500	ns
			6.0V		400	400	400	ns
C_{PD}	Power Dissipation Capacitance (Note 5)	(per package)		136			pF	
C_{IN}	Maximum Input Capacitance			5	10	10	10	pF

Note 5: C_{PD} determines the no load dynamic power consumption, $P_D = C_{PD} V_{CC}^2 f + I_{CC} V_{CC}$, and the no load dynamic current consumption, $I_S = C_{PD} V_{CC} f + I_{CC}$.

Physical Dimensions inches (millimeters) unless otherwise noted

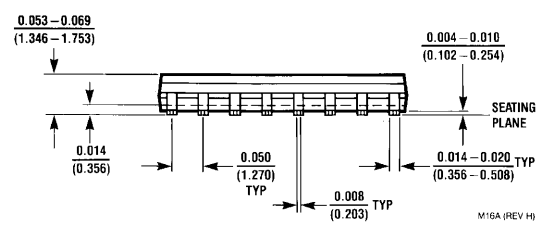
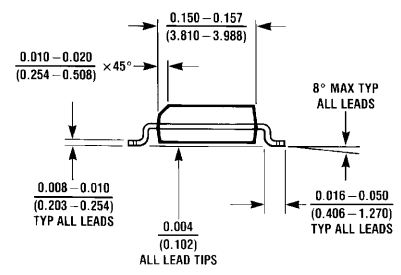
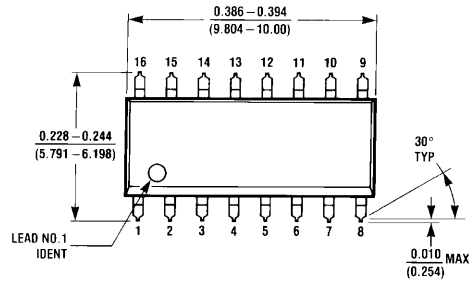

16-Lead Small Outline Integrated Circuit (SOIC) JEDEC MS-012, 0.150" Narrow Package Number M16A

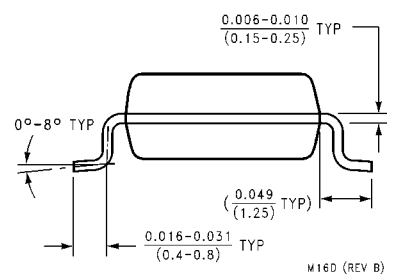
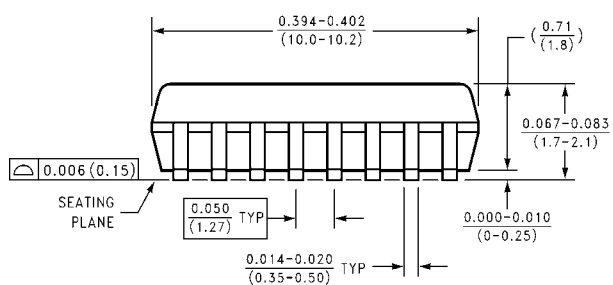
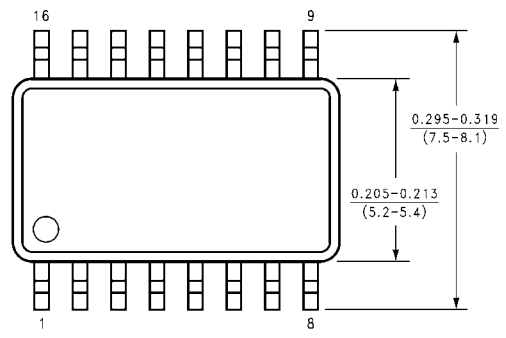

16-Lead Small Outline Package (SOP), EIAJ TYPE II, 5.3mm Wide Package Number M16D

Physical Dimensions inches (millimeters) unless otherwise noted (Continued)

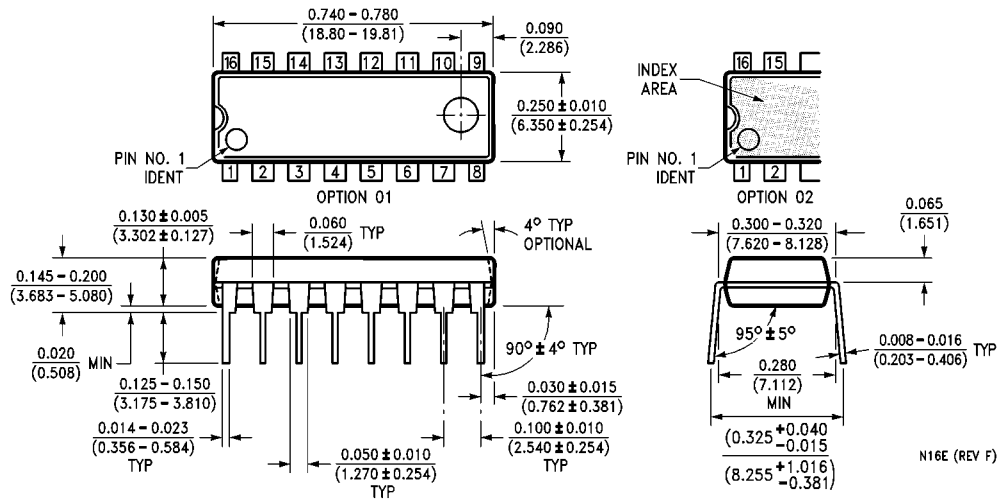

16-Lead Plastic Dual-In Line Package (PDIP), JEDEC MS-001, 0.300" Wide Package Number N16E

LIFE SUPPORT POLICY

FAIRCHILD'S PRODUCTS ARE NOT AUTHORIZED FOR USE AS CRITICAL COMPONENTS IN LIFE SUPPORT DEVICES OR SYSTEMS WITHOUT THE EXPRESS WRITTEN APPROVAL OF THE PRESIDENT OF FAIRCHILD SEMICONDUCTOR CORPORATION. As used herein:

1. Life support devices or systems are devices or systems which, (a) are intended for surgical implant into the body, or (b) support or sustain life, and (c) whose failure to perform when properly used in accordance with instructions for use provided in the labeling, can be reasonably expected to result in a significant injury to the user.
2. A critical component in any component of a life support device or system whose failure to perform can be reasonably expected to cause the failure of the life support device or system, or to affect its safety or effectiveness.

www.fairchildsemi.com