



# OCTAL D-TYPE FLIP-FLOP WITH 3-STATE OUTPUTS

The MC54/74F374 is a high-speed, low-power octal D-type flip-flop featuring separate D-type inputs for each flip-flop and 3-state outputs for bus oriented applications. A buffered Clock (CP) and Output Enable ( $\overline{OE}$ ) are common to all flip-flops.

- Edge-triggered D-Type Inputs
- Buffered Positive Edge-triggered Clock
- 3-State Outputs for Bus-Oriented Applications
- ESD > 4000 Volts

CONNECTION DIAGRAM (TOP VIEW)

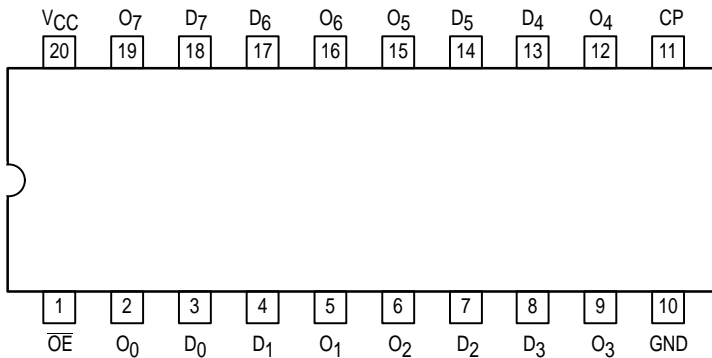

FUNCTION TABLE

Inputs		Outputs	
$D_n$	CP	$\overline{OE}$	$O_n$
H		L	H
L		L	L
X	X	H	Z

H = HIGH Voltage Level  
 L = LOW Voltage Level  
 X = Don't Care  
 Z = High Impedance

## MC54/74F374

### OCTAL D-TYPE FLIP-FLOP WITH 3-STATE OUTPUTS

FAST™ SCHOTTKY TTL

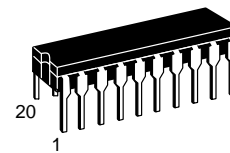

J SUFFIX  
 CERAMIC  
 CASE 732-03

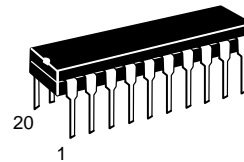

N SUFFIX  
 PLASTIC  
 CASE 738-03

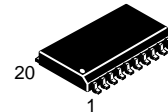

DW SUFFIX  
 SOIC  
 CASE 751D-03

#### ORDERING INFORMATION

MC54FXXXJ Ceramic  
 MC74FXXXN Plastic  
 MC74FXXXDW SOIC

#### LOGIC SYMBOL

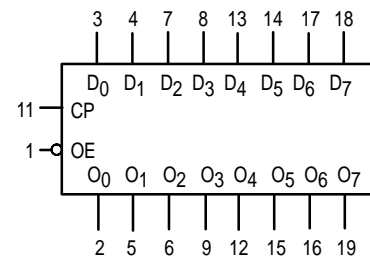

$V_{CC}$  = PIN 20  
 $GND$  = PIN 10

# MC54/74F374

## FUNCTIONAL DESCRIPTION

The F374 consists of eight edge-triggered flip-flops with individual D-type inputs and 3-state true outputs. The buffered clock and buffered Output Enable are common to all flip-flops. The eight flip-flops will store the state of their individual D inputs that meet the setup and hold time requirements on the

LOW-to-HIGH Clock (CP) transition. With the Output Enable ( $\overline{OE}$ ) LOW, the contents of the eight flip-flops are available at the outputs. When the  $\overline{OE}$  is HIGH, the outputs go to the high impedance state. Operation of the  $\overline{OE}$  input does not affect the state of the flip-flops.

## LOGIC DIAGRAM

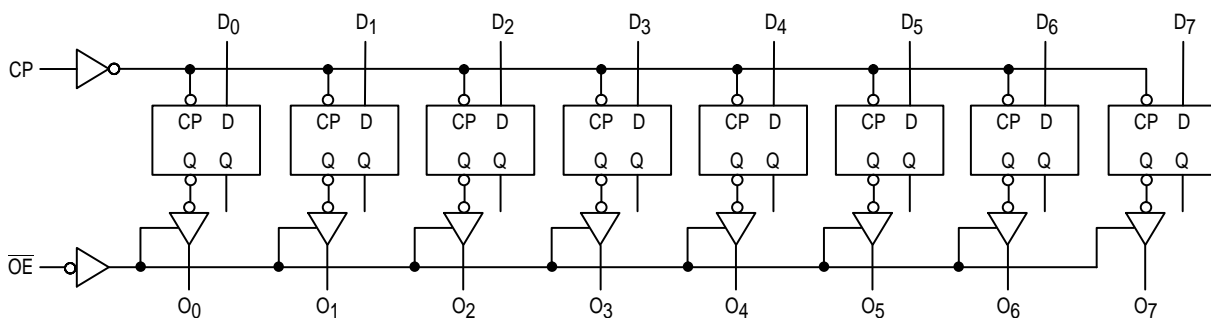

## DC CHARACTERISTICS OVER OPERATING TEMPERATURE RANGE (unless otherwise specified)

Symbol	Parameter	Limits			Unit	Test Conditions	
		Min	Typ	Max			
$V_{IH}$	Input HIGH Voltage	2.0			V	Guaranteed Input HIGH Voltage	
$V_{IL}$	Input LOW Voltage			0.8	V	Guaranteed Input LOW Voltage	
$V_{IK}$	Input Clamp Diode Voltage			-1.2	V	$I_{IN} = -18$ mA	$V_{CC} = \text{MIN}$
$V_{OH}$	Output HIGH Voltage	54, 74	2.4	3.3	V	$I_{OH} = -3.0$ mA	$V_{CC} = 4.5$ V
		74	2.7	3.3	V	$I_{OH} = -3.0$ mA	$V_{CC} = 4.75$ V
$V_{OL}$	Output LOW Voltage		0.35	0.5	V	$I_{OL} = 24$ mA	$V_{CC} = \text{MIN}$
$I_{OZH}$	Output OFF Current — HIGH			50	$\mu$ A	$V_{OUT} = 2.7$ V	$V_{CC} = \text{MAX}$
$I_{OZL}$	Output OFF Current — LOW			-50	$\mu$ A	$V_{OUT} = 0.5$ V	$V_{CC} = \text{MAX}$
$I_{IH}$	Input HIGH Current			20	$\mu$ A	$V_{IN} = 2.7$ V	$V_{CC} = \text{MAX}$
				100	$\mu$ A	$V_{IN} = 7.0$ V	$V_{CC} = \text{MAX}$
$I_{IL}$	Input LOW Current			-0.6	mA	$V_{IN} = 0.5$ V	$V_{CC} = \text{MAX}$
$I_{OS}$	Output Short Circuit Current (Note 2)	-60		-150	mA	$V_{OUT} = 0$ V	$V_{CC} = \text{MAX}$
$I_{CCZ}$	Power Supply Current (All Outputs OFF)		55	86	mA	$D_n = \text{GND}$ $\overline{OE} = 4.5$ V	$V_{CC} = \text{MAX}$

### NOTES:

- For conditions shown as MIN or MAX, use the appropriate value specified under recommended operating conditions for the applicable device type.
- Not more than one output should be shorted at a time, nor for more than 1 second.

# MC54/74F374

## GUARANTEED OPERATING RANGES

Symbol	Parameter		Min	Typ	Max	Unit
V <sub>CC</sub>	Supply Voltage	54, 74	4.5	5.0	5.5	V
T <sub>A</sub>	Operating Ambient Temperature Range	54	-55	25	125	°C
		74	0	25	70	
I <sub>OH</sub>	Output Current — HIGH	54, 74			-3.0	mA
I <sub>OL</sub>	Output Current — LOW	54, 74			24	mA

## AC CHARACTERISTICS

Symbol	Parameter	54/74F			54F		74F		Unit
		T <sub>A</sub> = +25°C V <sub>CC</sub> = +5.0 V C <sub>L</sub> = 50 pF			T <sub>A</sub> = -55°C to +125°C V <sub>CC</sub> = 5.0 V ± 10% C <sub>L</sub> = 50 pF		T <sub>A</sub> = 0°C to +70°C V <sub>CC</sub> = 5.0 V ± 10% C <sub>L</sub> = 50 pF		
		Min	Typ	Max	Min	Max	Min	Max	
f <sub>max</sub>	Maximum Clock Frequency	100			60		70		MHz
t <sub>PLH</sub>	Propagation Delay	4.0	6.5	8.5	4.0	10.5	4.0	10	ns
t <sub>PHL</sub>	CP to O <sub>n</sub>	4.0	6.5	8.5	4.0	11	4.0	10	
t <sub>PZH</sub>	Output Enable Time	2.0	9.0	11.5	2.0	14	2.0	12.5	ns
t <sub>PZL</sub>		2.0	5.8	7.5	2.0	10	2.0	8.5	
t <sub>PHZ</sub>	Output Disable Time	2.0	5.3	7.0	2.0	8.0	2.0	8.0	ns
t <sub>PLZ</sub>		2.0	4.3	5.5	2.0	7.5	2.0	6.5	

## AC OPERATING REQUIREMENTS

Symbol	Parameter	54/74F			54F		74F		Unit
		T <sub>A</sub> = +25°C V <sub>CC</sub> = +5.0 V			T <sub>A</sub> = -55°C to +125°C V <sub>CC</sub> = 5.0 V ± 10%		T <sub>A</sub> = 0°C to +70°C V <sub>CC</sub> = 5.0 V ± 10%		
		Min	Typ	Max	Min	Max	Min	Max	
t <sub>S</sub> (H)	Setup Time, HIGH or LOW	2.0			2.5		2.0		ns
t <sub>S</sub> (L)	D <sub>n</sub> to CP	2.0			2.0		2.0		
t <sub>H</sub> (H)	Hold Time, HIGH or LOW	2.0			2.0		2.0		
t <sub>H</sub> (L)	D <sub>n</sub> to CP	2.0			2.5		2.0		
t <sub>w</sub> (H)	CP Pulse Width,	7.0			7.0		7.0		ns
t <sub>w</sub> (L)	HIGH or LOW	6.0			6.0		6.0		