

DUAL RETRIGGERABLE MONOSTABLE MULTIVIBRATOR

- HIGH SPEED
 $t_{PD} = 25 \text{ ns (TYP.) AT } V_{CC} = 5 \text{ V}$
- LOW POWER DISSIPATION
 STANDBY STATE $I_{CC} = 4 \mu\text{A (MAX.) AT } T_A = 25^\circ\text{C}$
 ACTIVE STATE $I_{CC} = 200 \mu\text{A (TYP.) AT } V_{CC} = 5 \text{ V}$
- HIGH NOISE IMMUNITY
 $V_{NIH} = V_{NIL} = 28 \% V_{CC} \text{ (MIN.)}$
- OUTPUT DRIVE CAPABILITY
 10 LSTTL LOADS
- BALANCED PROPAGATION DELAYS
 $t_{PLH} = t_{PHL}$
- WIDE OUTPUT PULSE WIDTH RANGE
 $t_{WOUT} = 120 \text{ ns} \sim 60 \text{ s OVER AT } V_{CC} = 4.5 \text{ V}$
- OUTPUT PULSE WIDTH INDEPENDENT
 FROM TRIGGER INPUT PULSE WIDTH
- PIN AND FUNCTION COMPATIBLE
 WITH 4538B

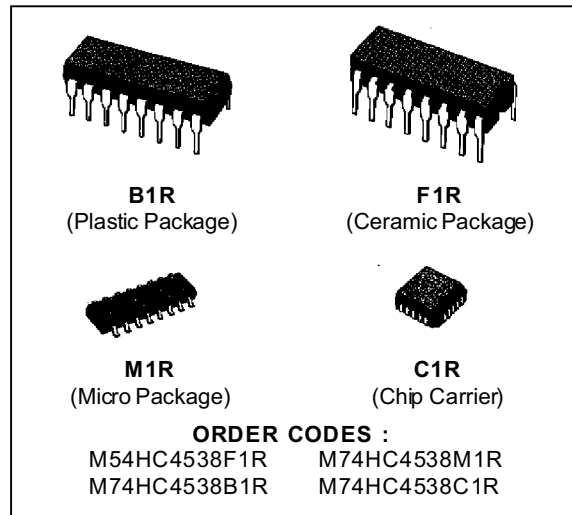

DESCRIPTION

The M54/74HC4538 is a high speed CMOS DUAL MONOSTABLE MULTIVIBRATOR fabricated in silicon gate C²MOS technology. It has the same high speed performance of LSTTL combined with true CMOS low power consumption. Each multivibrator features both a negative, A, and a positive, B, edge triggered input, either of which can be used as an inhibit input. Also included is a clear input that when taken low resets the one shot. The monostable multivibrators are retriggerable. That is, they may be triggered repeatedly while their outputs are generating a pulse and the pulse will be extended. Pulse width stability over a wide range of temperature and supply is achieved using linear CMOS techniques. The output pulse equation is simply : $PW = 0.7 (R)(C)$ where PW is in seconds, R in Ohms, and C is in Farads.

All inputs are equipped with protection circuits against static discharge and transient excess voltage.

PIN CONNECTIONS (top view)

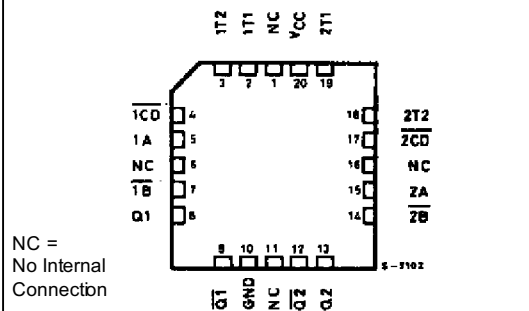
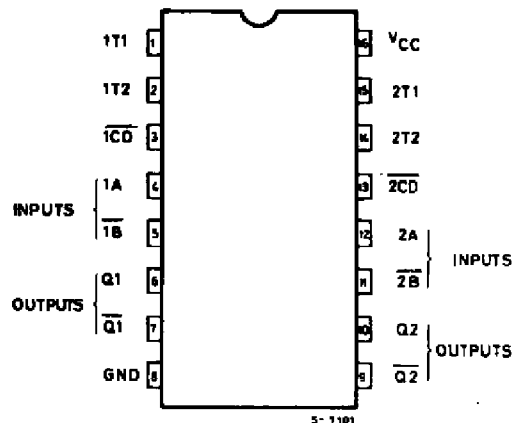

M54/M74HC4538

SYSTEM DIAGRAM

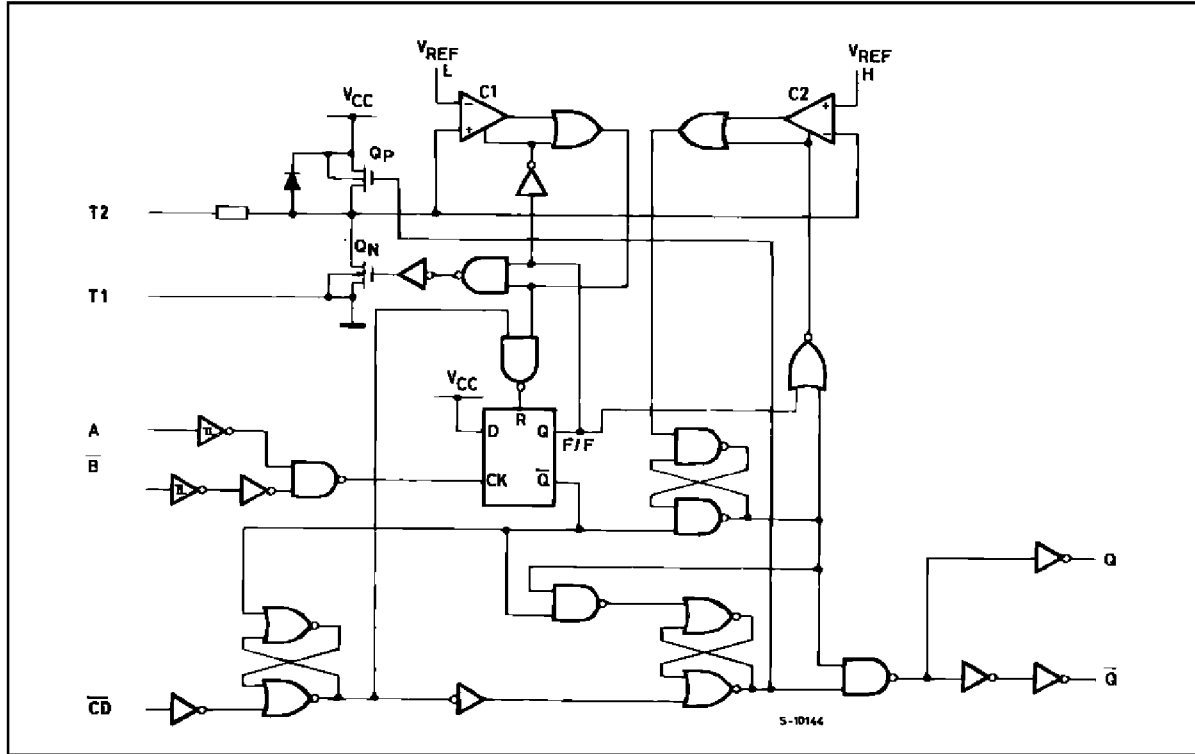

TIMING CHART

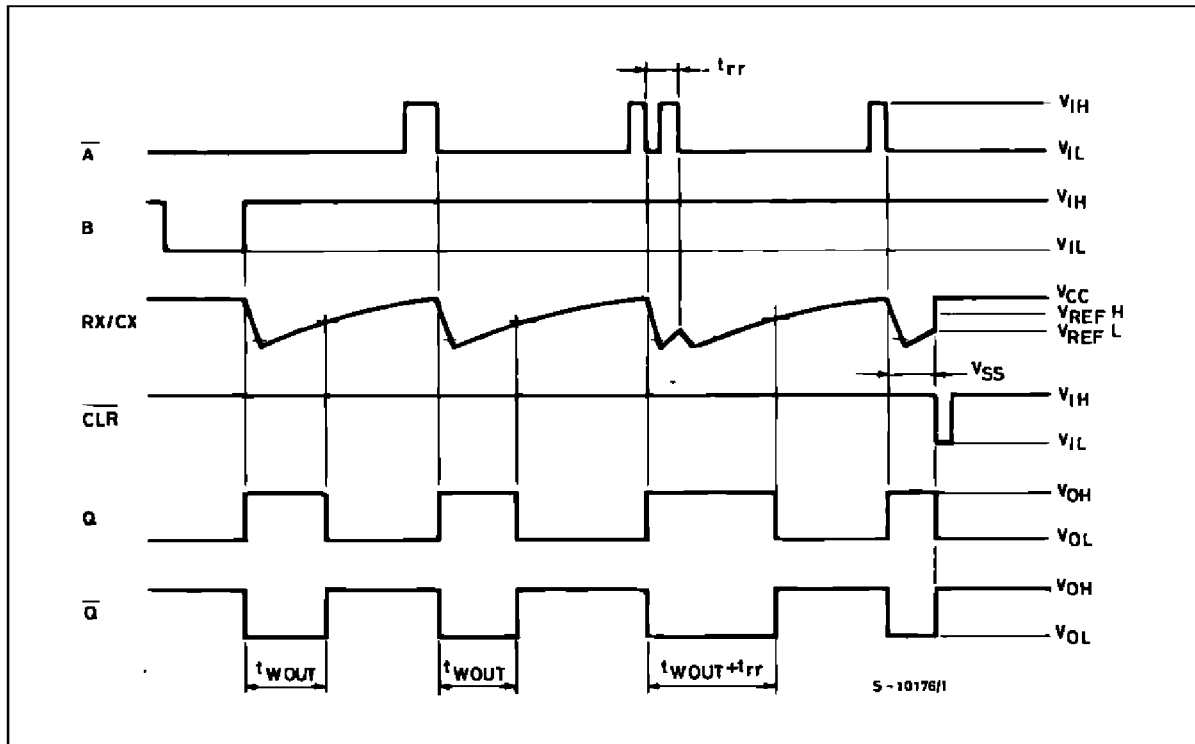

BLOCK DIAGRAM

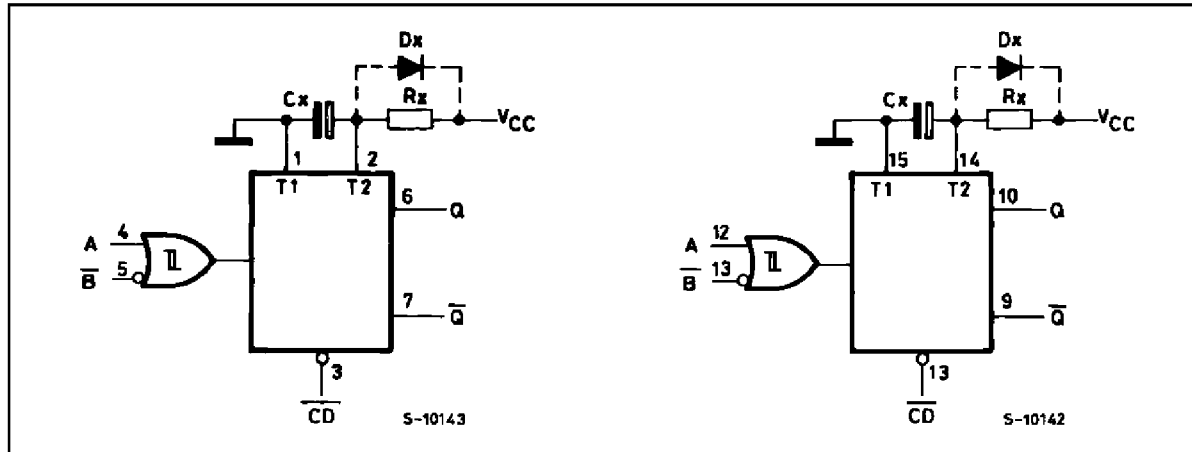

Notes : 1. Cx, Rx, Dx are external components.

2. Dx is a clamping diode.

3. The external capacitor is charged to V_{CC} in the stand-by state, i.e. no trigger. When the supply voltage is turned off Cx is discharged mainly through an internal parasitic diode (see figures). If Cx is sufficiently large and V_{CC} decreases rapidly, there will be some possibility of damaging the I.C. with a surge current or latch-up. If the voltage supply filter capacitor is large enough and V_{CC} decrease slowly, the surge current is automatically limited and damage the I.C. is avoided. The maximum forward current of the parasitic diode is approximately 20 mA. In cases where Cx is large the time taken for the supply voltage to fall to $0.4 V_{CC}$ can be calculated as follows : $t_f \geq (V_{CC} - 0.7) \cdot Cx / 20 \text{ mA}$

In cases where t_f is too short an external clamping diode is required to protect the I.C. from the surge current.

FUNCTIONAL DESCRIPTION

STAND-BY STATE

The external capacitor, Cx, is fully charged to V_{CC} in the stand-by state. Hence, before triggering, transistor Qp and Qn (connected to the Rx/Cx node) are both turned off. The two comparators that control the timing and the two reference voltage sources stop operating. The total supply current is therefore only leakage current.

TRIGGER OPERATION

Triggering occurs when :

1 st) A is "low" and \bar{B} has a falling edge ;

2 nd) \bar{B} is "high" and A has a rising edge ;

After the multivibrator has been retriggered comparator C1 and C2 start operating and Qn is turned on. Cx then discharges through Qn. The voltage at the node Rx/Cx external falls.

When it reaches V_{REFL} the output of comparator C1 becomes low. This in turn resets the flip-flop and Qn is turned off.

At this point C1 stops functioning but C2 continues to operate. The voltage at R/C external begins to rise with a time constant set by the external components Rx, Cx.

Triggering the multivibrator causes Q to go high after internal delay due to the flip-flop and the gate. Q remains high until the voltage at R/C external rises again to V_{REFH} . At this point C2 output goes low and G goes low. C2 stops operating. That means that after triggering when the voltage at R/C external returns to V_{REFH} the multivibrator has returned to its MONOSTABLE STATE. In the case where $Rx \cdot Cx$ are large enough and the discharge time of the capacitor and the delay time in the I.C. can be ignored, the width of the output pulse t_w (out) is as follows :

$$t_{w(OUT)} = 0.72 Cx \cdot Rx$$

RE-TRIGGER OPERATION

When a second trigger pulse follows the first its effect will depend on the state of the multivibrator. If the capacitor Cx is being charged the voltage level of Rx/Cx external falls to V_{REFL} again and Q remains high i.e. the retrigger pulse arrives in a time shorter than the period $Rx \cdot Cx$ seconds, the capacitor charging time constant. If the second trigger pulse is very close to the initial trigger pulse it is ineffective ; i.e., the second trigger must arrive in the capacitor discharge cycle to be ineffective.

Hence the minimum time for a second trigger to be effective, t_{rr} (Min.) depends on V_{CC} and Cx.

M54/M74HC4538

FUNCTIONAL DESCRIPTION (continued)

RESET OPERATION

\overline{CD} is normally high. If \overline{CD} is low, the trigger is not effective because Q output goes low and trigger control flip-flop is reset.

Also transistor Op is turned on and Cx is charged quickly to V_{CC} . This means if \overline{CD} input goes low, the IC becomes waiting state both in operating and non operating state.

TRUTH TABLE

INPUTS			OUTPUTS		NOTE
A	\overline{B}	\overline{CD}	Q	\overline{Q}	
	H	H			OUTPUT ENABLE
X	L	H	L	H	INHIBIT
H	X	H	L	H	INHIBIT
L		H			OUTPUT ENABLE
X	X	L	L	H	INHIBIT

INPUT AND OUTPUT EQUIVALENT CIRCUIT

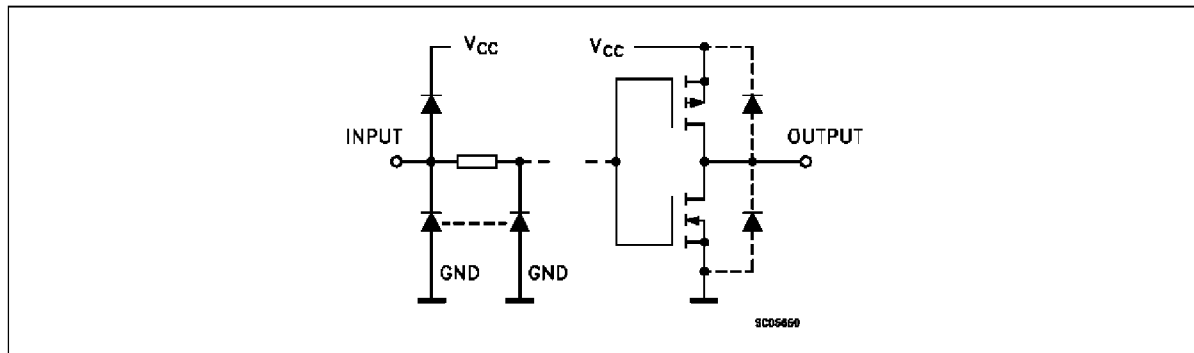

PIN DESCRIPTION

PIN No	SYMBOL	NAME AND FUNCTION
1, 15	1T1, 2T1	External Capacitor Connections
2, 14	1T2, 2T2	External Resistor/Capacitor Connections
3, 13	$\overline{1CD}$, $\overline{2CD}$	Direct Reset Inputs (Active LOW)
4, 12	1A, 2A	Trigger Inputs (LOW to HIGH, Edge-Triggered)
5, 11	$\overline{1B}$, $\overline{2B}$	Trigger Inputs (HIGH to LOW, Edge-Triggered)
6, 10	Q1, Q2	Pulse Outputs
7, 9	$\overline{Q1}$, $\overline{Q2}$	Complementary Pulse Outputs
8	GND	Ground (0V)
16	V_{CC}	Positive Supply Voltage

IEC LOGIC SYMBOL

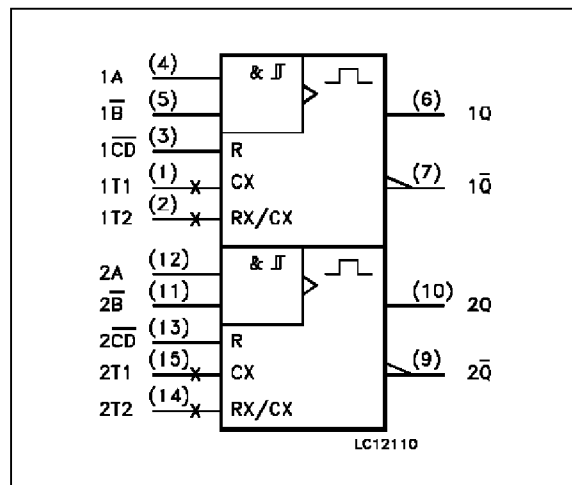

ABSOLUTE MAXIMUM RATINGS

Symbol	Parameter	Value	Unit
V _{CC}	Supply Voltage	-0.5 to +7	V
V _I	DC Input Voltage	-0.5 to V _{CC} + 0.5	V
V _O	DC Output Voltage	-0.5 to V _{CC} + 0.5	V
I _{IK}	DC Input Diode Current	± 20	mA
I _{OK}	DC Output Diode Current	± 20	mA
I _O	DC Output Source Sink Current Per Output Pin	± 25	mA
I _{CC} or I _{GND}	DC V _{CC} or Ground Current	± 50	mA
P _D	Power Dissipation	500 (*)	mW
T _{stg}	Storage Temperature	-65 to +150	°C
T _L	Lead Temperature (10 sec)	300	°C

Absolute Maximum Ratings are those values beyond which damage to the device may occur. Functional operation under these condition is not implied.
 (*) 500 mW: ≡ 65 °C derate to 300 mW by 10mW/°C: 65 °C to 85 °C

RECOMMENDED OPERATING CONDITIONS

Symbol	Parameter	Value	Unit	
V _{CC}	Supply Voltage	2 to 6	V	
V _I	Input Voltage	0 to V _{CC}	V	
V _O	Output Voltage	0 to V _{CC}	V	
T _{op}	Operating Temperature: M54HC Series M74HC Series	-55 to +125 -40 to +85	°C °C	
t _r , t _f	Input Rise and Fall Time (CLR only)	V _{CC} = 2 V V _{CC} = 4.5 V V _{CC} = 6 V	0 to 1000 0 to 500 0 to 400	ns
C _X	External Capacitor	NO LIMITATION (*)		
R _X	External Resistor	V _{CC} ≤ 3 V V _{CC} > 3 V	5K to 1M (*) 1K to 1M (*)	Ω

(*) The maximum allowable values of C_x and R_x are a function of leakage of capacitor C_x, the leakage of device and leakage due to the board layout and surface resistance. Susceptibility to externally induced noise may occur for R_x > 1MΩ

M54/M74HC4538

DC SPECIFICATIONS

Symbol	Parameter	Test Conditions		Value						Unit		
		V _{CC} (V)		T _A = 25 °C 54HC and 74HC			-40 to 85 °C 74HC		-55 to 125 °C 54HC			
				Min.	Typ.	Max.	Min.	Max.	Min.		Max.	
V _{IH}	High Level Input Voltage	2.0		1.5			1.5		1.5		V	
		4.5		3.15			3.15		3.15			
		6.0		4.2			4.2		4.2			
V _{IL}	Low Level Input Voltage	2.0				0.5		0.5		0.5	V	
		4.5				1.35		1.35		1.35		
		6.0				1.8		1.8		1.8		
V _{OH}	High Level Output Voltage	2.0	V _I = V _{IH} or V _{IL}	I _O = -20 μA	1.9	2.0		1.9		1.9	V	
		4.5			4.4	4.5		4.4		4.4		
		6.0			5.9	6.0		5.9		5.9		
		4.5	I _O = -4.0 mA	4.18	4.31		4.13		4.10			
		6.0		I _O = -5.2 mA	5.68	5.8		5.63		5.60		
V _{OL}	Low Level Output Voltage	2.0	V _I = V _{IH} or V _{IL}	I _O = 20 μA		0.0	0.1		0.1		0.1	V
		4.5				0.0	0.1		0.1		0.1	
		6.0				0.0	0.1		0.1		0.1	
		4.5	I _O = 4.0 mA		0.17	0.26		0.37		0.40		
		6.0		I _O = 5.2 mA		0.18	0.26		0.37		0.40	
I _I	Input Leakage Current	6.0	V _I = V _{CC} or GND			±0.1		±1		±1	μA	
I _I	Input Leakage Current	6.0	V _I = V _{CC} or GND R _{ext} /C _{ext}			±0.1		±1		±1	μA	
I _{CC}	Quiescent Supply Current	6.0	V _I = V _{CC} or GND			4		40		80	μA	
I _{CC}	Quiescent Supply Current	2.0	V _I = V _{CC} or GND pins 2, 14 V _I = V _{CC} /2		40	120		160			μA	
		4.5			0.2	0.3		0.4			mA	
		6.0			0.3	0.6		0.8			mA	

AC ELECTRICAL CHARACTERISTICS ($C_L = 50$ pF, Input $t_r = t_f = 6$ ns)

Symbol	Parameter	Test Conditions		Value						Unit		
		V _{CC} (V)		T _A = 25 °C 54HC and 74HC			-40 to 85 °C 74HC		-55 to 125 °C 54HC			
				Min.	Typ.	Max.	Min.	Max.	Min.		Max.	
t _{TLH} t _{THL}	Output Transition Time	2.0			30	75		95		110	ns	
		4.5			8	15		19		22		
		6.0			7	13		16		19		
t _{PLH} t _{PHL}	Propagation Delay Time (A, B - Q, Q)	2.0			120	250		315		375	ns	
		4.5			30	50		63		75		
		6.0			25	43		54		64		
t _{PLH} t _{PHL}	Propagation Delay Time (CD - Q, Q)	2.0			100	195		245		295	ns	
		4.5			25	39		49		59		
		6.0			20	33		42		50		
t _{WOUT}	Output Pulse Width	2.0	C _X = 0	R _X = 5KΩ	540	1200		1500		1800	ns	
		4.5		R _X = 1KΩ	180	250		320		375		
		6.0		R _X = 1KΩ	150	200		260		320		
		2.0	C _X = 0.01 μF R _X = 10KΩ		70	83	96	70	96	70	96	μs
		4.5			69	77	85	69	85	69	85	
		6.0			69	77	85	69	85	69	85	
		2.0	C _X = 0.1 μF R _X = 10KΩ		0.67	0.75	0.83	0.67	0.83	0.67	0.9	ms
		4.5			0.67	0.73	0.77	0.67	0.77	0.67	0.8	
		6.0			0.67	0.73	0.77	0.67	0.77	0.67	0.8	
Δt _{WOUT}	Output Pulse Width Error Between Circuits (In same pack)				±1						%	
t _{W(H)} t _{W(L)}	Minimum Pulse Width (CLOCK)	2.0			30	75		95		110	ns	
		4.5			8	15		19		22		
		6.0			7	13		16		19		
t _{W(L)}	Minimum Pulse Width (CLEAR)	2.0			30	75		95		110	ns	
		4.5			8	15		19		22		
		6.0			7	13		16		19		
t _{REM}	Minimum Clear Removal Time	2.0			0	15		15		20	ns	
		4.5			0	5		5		7		
		6.0			0	5		5				
t _s	Minimum Retrigger Time	2.0	C _X = 0.1 μF R _X = 1KΩ		380					6	ns	
		4.5			92							
		6.0			72							
		2.0	C _X = 0.01 μF R _X = 1KΩ		6							μs
		4.5			1.4							
		6.0			1.2							
C _{IN}	Input Capacitance				5	10		10		10	pF	
C _{PD} (*)	Power Dissipation Capacitance				70						pF	

(*) C_{PD} is defined as the value of the IC's internal equivalent capacitance which is calculated from the operating current consumption without load. (Refer to Test Circuit). Average operating current can be obtained by the following equation. $I_{CC(opr)} = C_{PD} \bullet V_{CC} \bullet f_{IN} + I_{CC'} \bullet Duty/100 + I_{CC}/2$ (per circuit)
(I_{CC'} = Active Supply Current)
(Duty = %))

M54/M74HC4538

TEST CIRCUIT I_{CC} (Opr.)

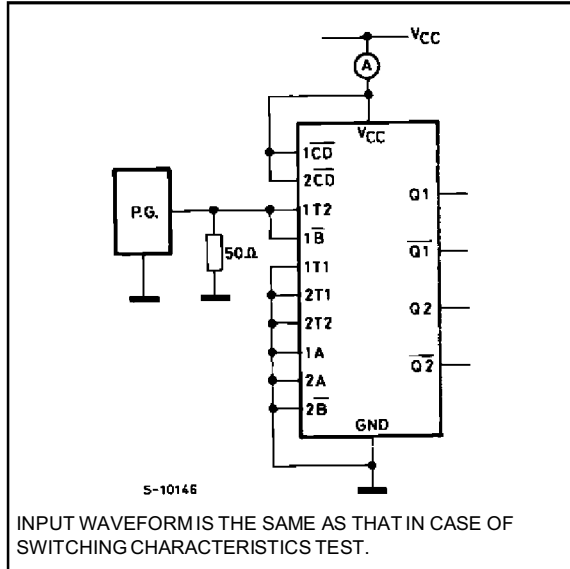

Output Pulse Width Constant $K = \text{Supply Voltage}$.

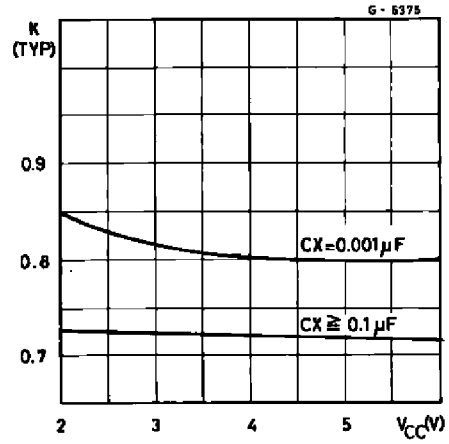

$t_{WOUT} - C_X$ Characteristics (Typ).

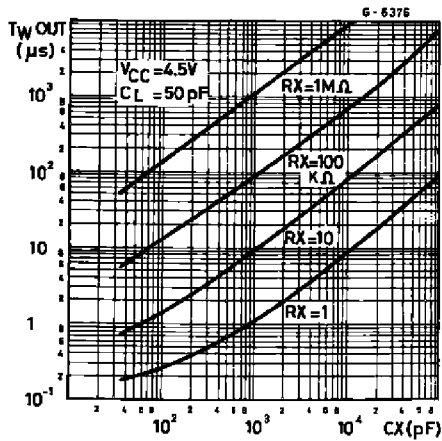

$t_{RR} - V_{CC}$ Characteristics (Typ).

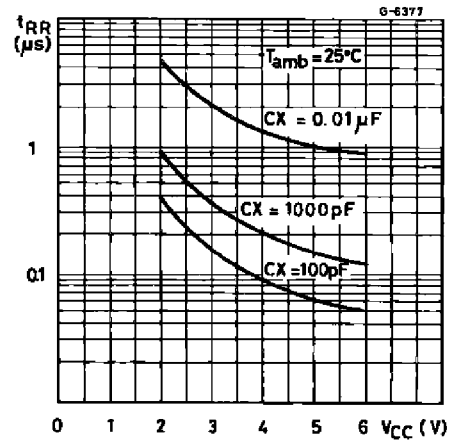

SWITCHING CHARACTERISTICS TEST WAVEFORM

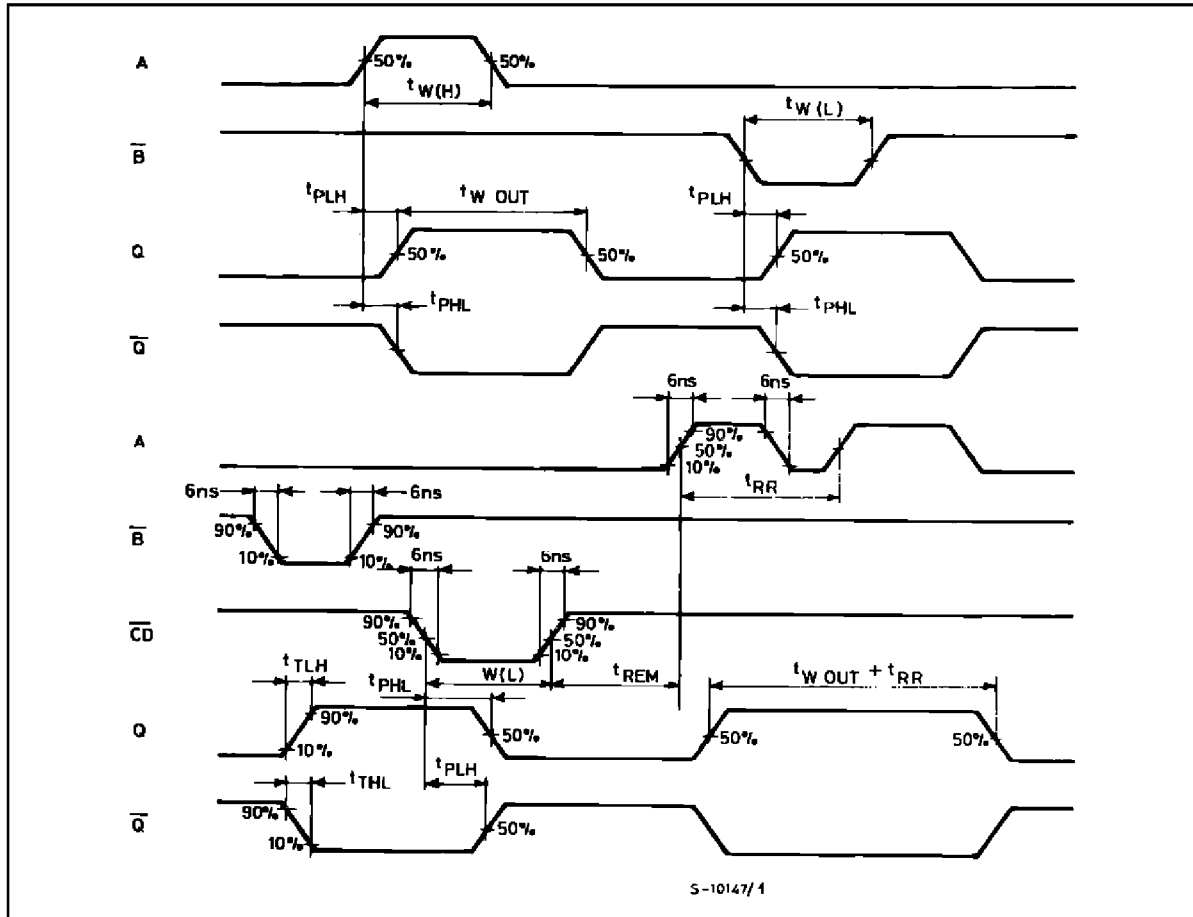

Plastic DIP16 (0.25) MECHANICAL DATA

DIM.	mm			inch		
	MIN.	TYP.	MAX.	MIN.	TYP.	MAX.
a1	0.51			0.020		
B	0.77		1.65	0.030		0.065
b		0.5			0.020	
b1		0.25			0.010	
D			20			0.787
E		8.5			0.335	
e		2.54			0.100	
e3		17.78			0.700	
F			7.1			0.280
I			5.1			0.201
L		3.3			0.130	
Z			1.27			0.050

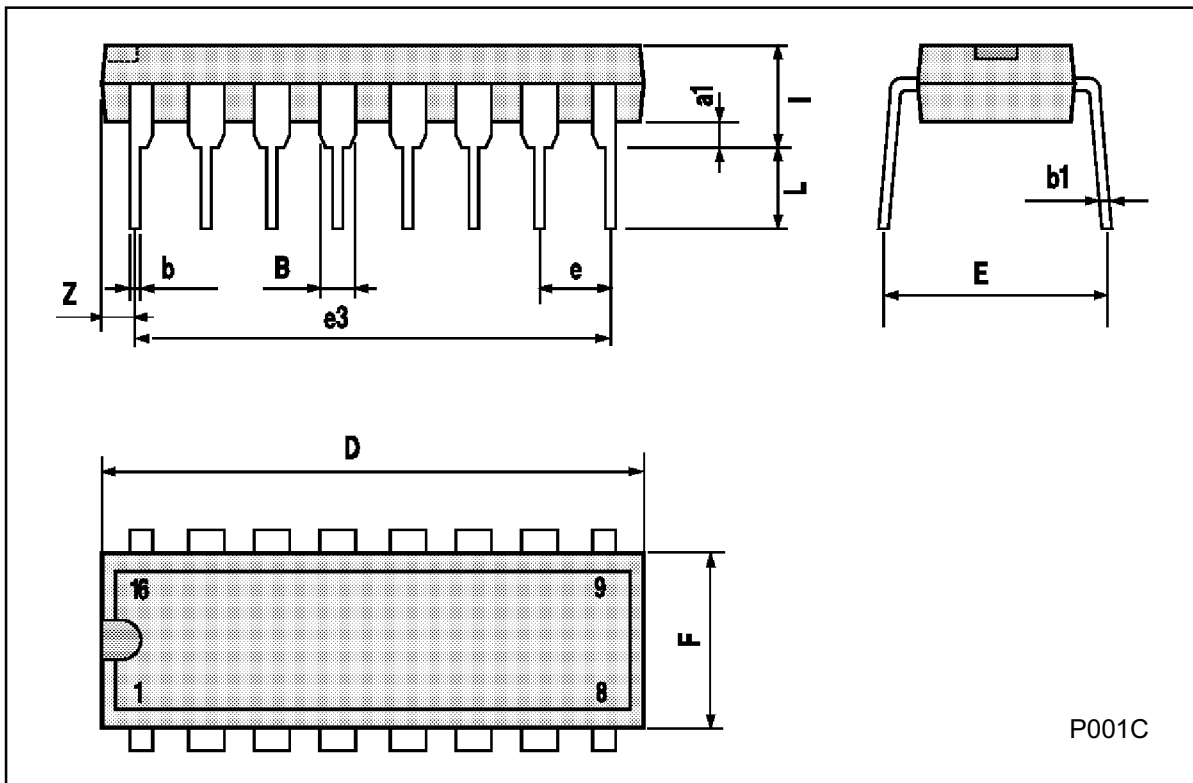

Ceramic DIP16/1 MECHANICAL DATA

DIM.	mm			inch		
	MIN.	TYP.	MAX.	MIN.	TYP.	MAX.
A			20			0.787
B			7			0.276
D		3.3			0.130	
E	0.38			0.015		
e3		17.78			0.700	
F	2.29		2.79	0.090		0.110
G	0.4		0.55	0.016		0.022
H	1.17		1.52	0.046		0.060
L	0.22		0.31	0.009		0.012
M	0.51		1.27	0.020		0.050
N			10.3			0.406
P	7.8		8.05	0.307		0.317
Q			5.08			0.200

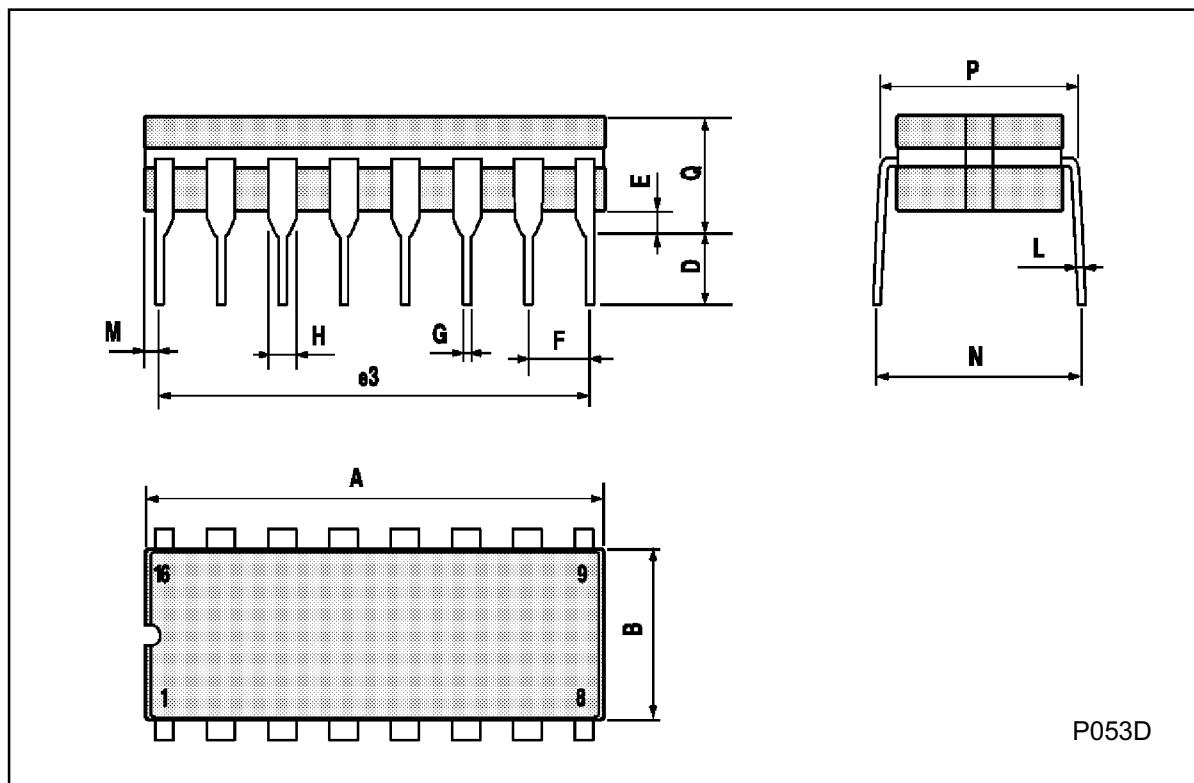

SO16 (Narrow) MECHANICAL DATA

DIM.	mm			inch		
	MIN.	TYP.	MAX.	MIN.	TYP.	MAX.
A			1.75			0.068
a1	0.1		0.2	0.004		0.007
a2			1.65			0.064
b	0.35		0.46	0.013		0.018
b1	0.19		0.25	0.007		0.010
C		0.5			0.019	
c1	45° (typ.)					
D	9.8		10	0.385		0.393
E	5.8		6.2	0.228		0.244
e		1.27			0.050	
e3		8.89			0.350	
F	3.8		4.0	0.149		0.157
G	4.6		5.3	0.181		0.208
L	0.5		1.27	0.019		0.050
M			0.62			0.024
S	8° (max.)					

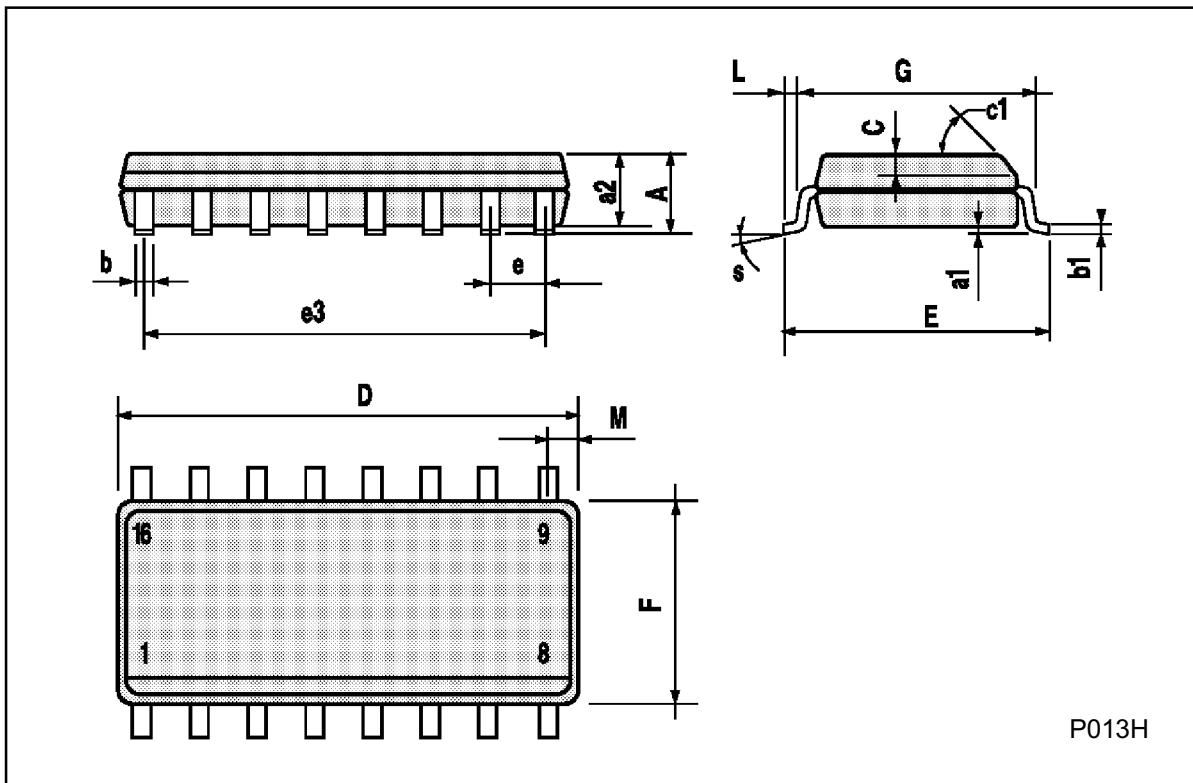

PLCC20 MECHANICAL DATA

DIM.	mm			inch		
	MIN.	TYP.	MAX.	MIN.	TYP.	MAX.
A	9.78		10.03	0.385		0.395
B	8.89		9.04	0.350		0.356
D	4.2		4.57	0.165		0.180
d1		2.54			0.100	
d2		0.56			0.022	
E	7.37		8.38	0.290		0.330
e		1.27			0.050	
e3		5.08			0.200	
F		0.38			0.015	
G			0.101			0.004
M		1.27			0.050	
M1		1.14			0.045	

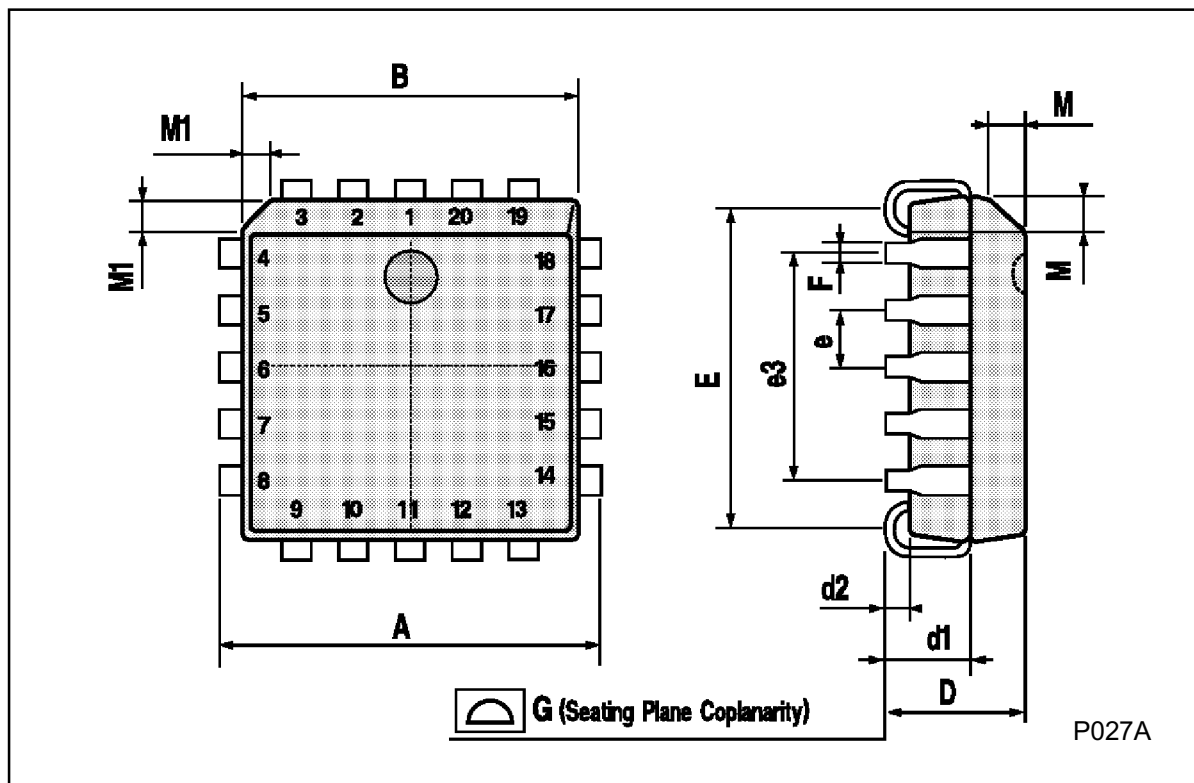

Information furnished is believed to be accurate and reliable. However, SGS-THOMSON Microelectronics assumes no responsibility for the consequences of use of such information nor for any infringement of patents or other rights of third parties which may result from its use. No license is granted by implication or otherwise under any patent or patent rights of SGS-THOMSON Microelectronics. Specifications mentioned in this publication are subject to change without notice. This publication supersedes and replaces all information previously supplied. SGS-THOMSON Microelectronics products are not authorized for use as critical components in life support devices or systems without express written approval of SGS-THOMSON Microelectronics.

© 1994 SGS-THOMSON Microelectronics - All Rights Reserved

SGS-THOMSON Microelectronics GROUP OF COMPANIES
Australia - Brazil - France - Germany - Hong Kong - Italy - Japan - Korea - Malaysia - Malta - Morocco - The Netherlands -
Singapore - Spain - Sweden - Switzerland - Taiwan - Thailand - United Kingdom - U.S.A