

4 BIT SYNCHRONOUS UP/DOWN COUNTERS

- HIGH SPEED
 $f_{MAX} = 48 \text{ MHz (TYP.) AT } V_{CC} = 5 \text{ V}$
- LOW POWER DISSIPATION
 $I_{CC} = 4 \mu\text{A (MAX.) AT } T_A = 25 \text{ }^\circ\text{C}$
- HIGH NOISE IMMUNITY
 $V_{NIH} = V_{NIL} = 28 \% V_{CC} \text{ (MIN.)}$
- OUTPUT DRIVE CAPABILITY
 10 LSTTL LOADS
- SYMMETRICAL OUTPUT IMPEDANCE
 $|I_{OH}| = I_{OL} = 4 \text{ mA (MIN.)}$
- BALANCED PROPAGATION DELAYS
 $t_{PLH} = t_{PHL}$
- WIDE OPERATING VOLTAGE RANGE
 $V_{CC} \text{ (OPR)} = 2 \text{ V TO } 6 \text{ V}$
- PIN AND FUNCTION COMPATIBLE
 WITH 54/74LS190/191

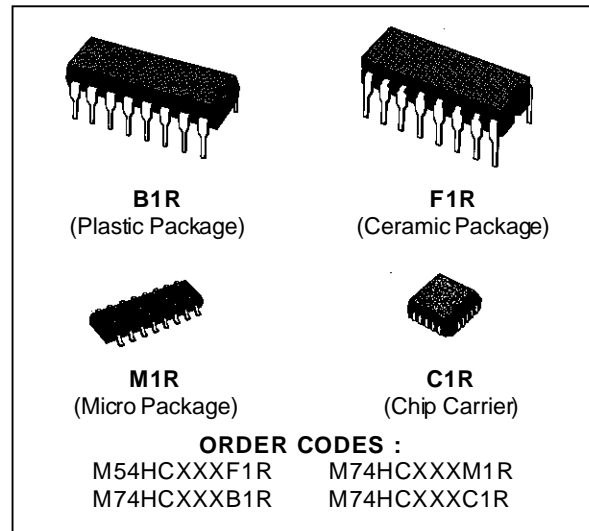

DESCRIPTION

The M54/74HC190/191 are high speed CMOS 4-BIT SYNCHRONOUS UP/DOWN COUNTERS fabricated in silicon gate C²MOS technology.

They have the same high speed performance of LSTTL combined with true CMOS low power consumption.

State changes of the counter are synchronous with the LOW-to-HIGH transition of the Clock Pulse input.

An asynchronous parallel load input overrides counting and loads the data present on the DATA inputs into the flip-flops, which makes it possible to use the circuits as programmable counters. A count enable input serves as the carry/borrow input in multi-stage counters. Control input, Down/Up, determines whether a circuit counts up or down. A MAX/MIN output and a Ripple Clock output provide overflow/underflow indication and make possible a variety of methods for generating carry/borrow signals in multi-stage counter applications.

All inputs are equipped with protection circuits against static discharge and transient excess voltage.

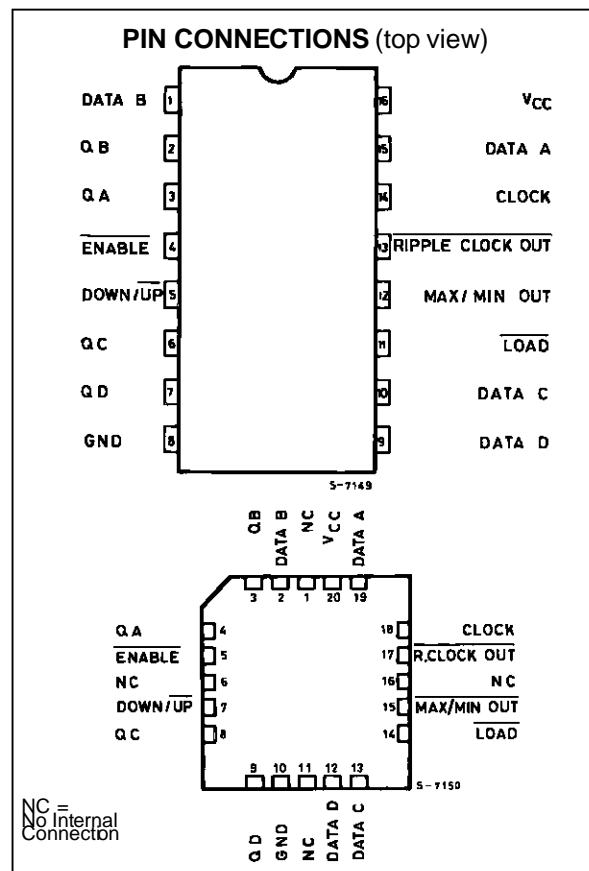

INPUT AND OUTPUT EQUIVALENT CIRCUIT

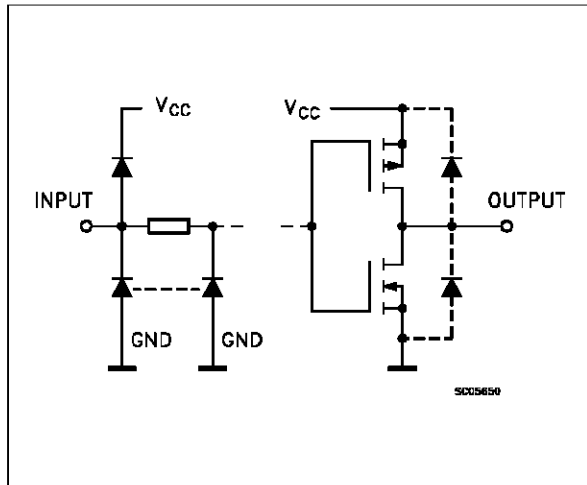

PIN DESCRIPTION

PIN No	SYMBOL	NAME AND FUNCTION
3, 2, 6, 7	QA to QD	Flip-Flop Outputs
4	$\overline{\text{ENABLE}}$	Count Enable Input (Active LOW)
5	$\overline{\text{U/D}}$	Parallel Data Input
11	LOAD	Load Input (Active LOW)
12	MA/MI OUT	Terminal Count Output
13	$\overline{\text{RC}}$	Ripple Clock Output (Active LOW)
14	CLOCK	Clock Input (LOW to HIGH, Edge-triggered)
15, 1, 10, 9	DA to DD	Data Inputs
8	GND	Ground (0V)
16	Vcc	Positive Supply Voltage

IEC LOGIC SYMBOL (HC190)

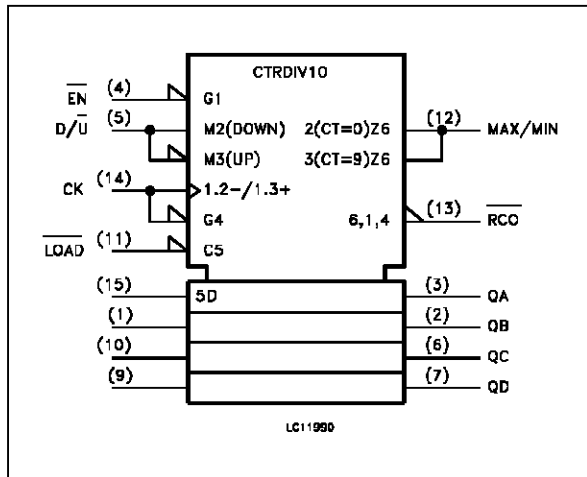

IEC LOGIC SYMBOL (HC191)

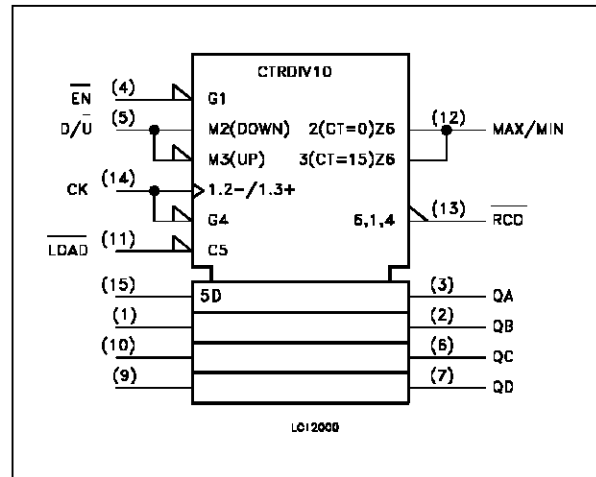

TRUTH TABLE

INPUTS				OUTPUTS				FUNCTION
LOAD	ENABLE	D/U	CLOCK	QA	QB	QC	QD	
L	X	X	X	a	b	c	d	PRESET DATA
H	L	L	\square	UP COUNT				UP COUNT
H	L	H	\square	DOWN COUNT				DOWN COUNT
H	H	X	\square	NO CHANGE				NO COUNT
H	X	X	\square	NO CHANGE				NO COUNT

X: Don't Care

a - d: The level of steady state inputs at inputs a through d respectively

LOGIC DIAGRAM (HC190)

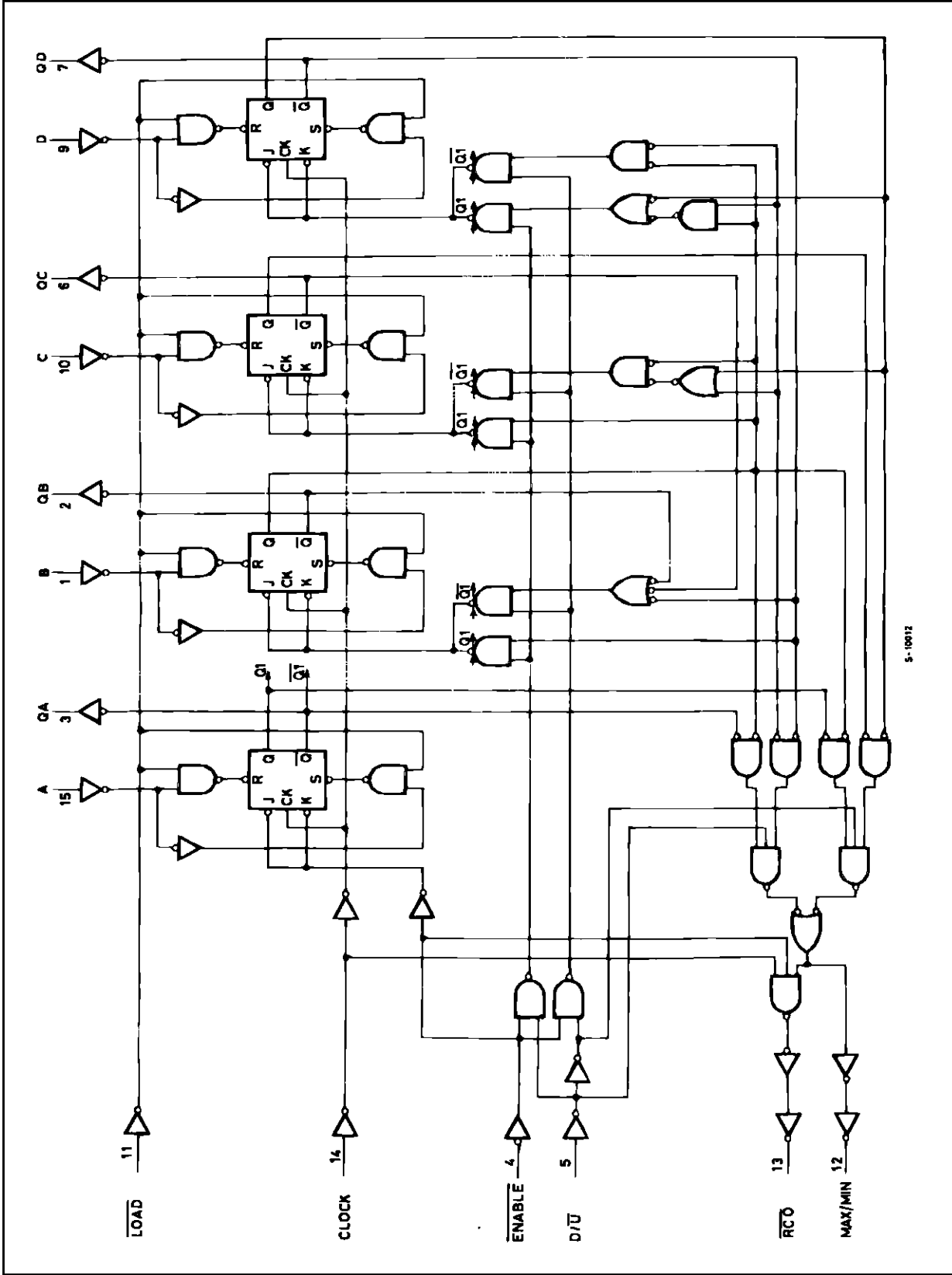

LOGIC DIAGRAM (HC191)

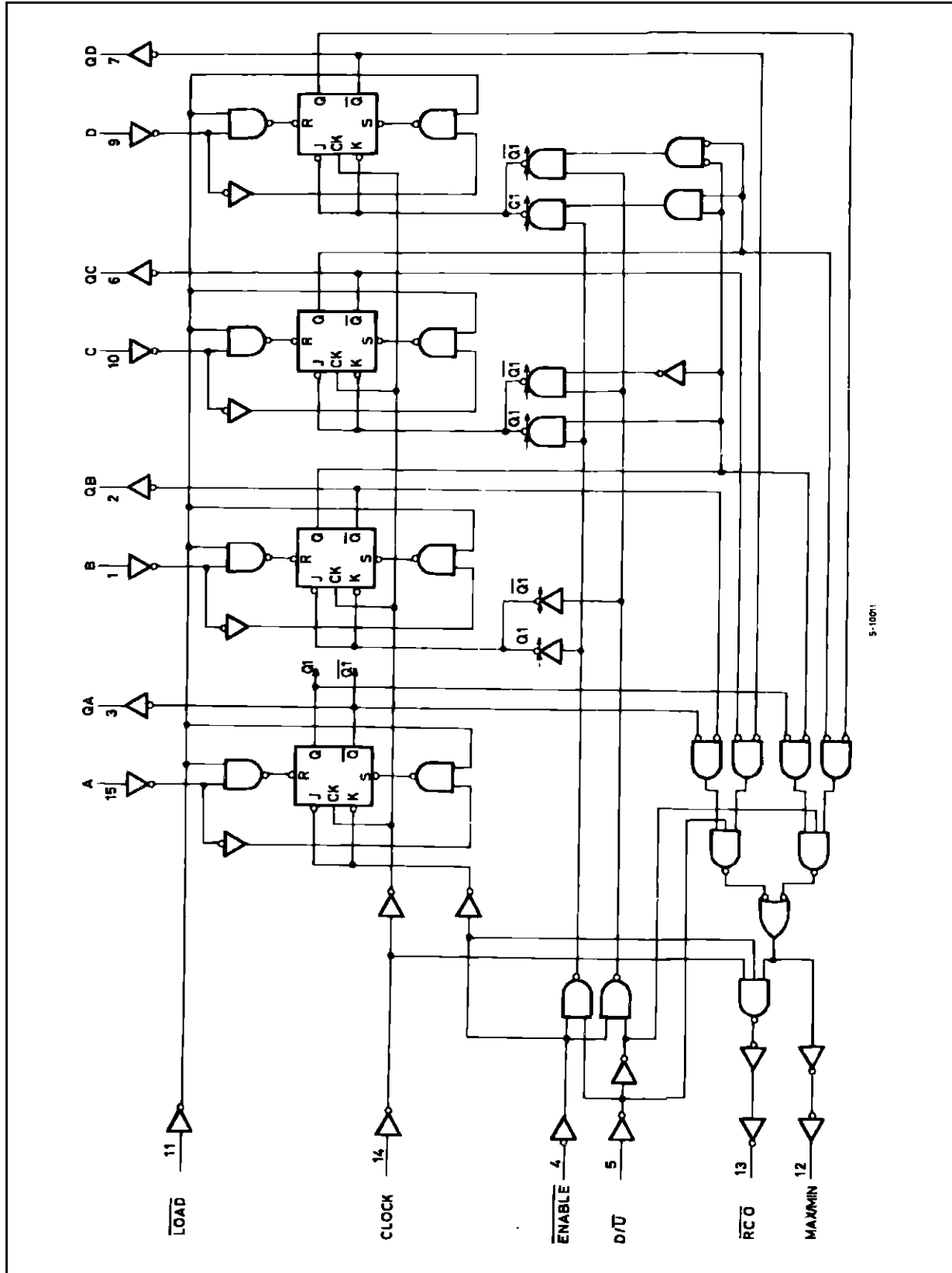

TIMING CHART (HC190)

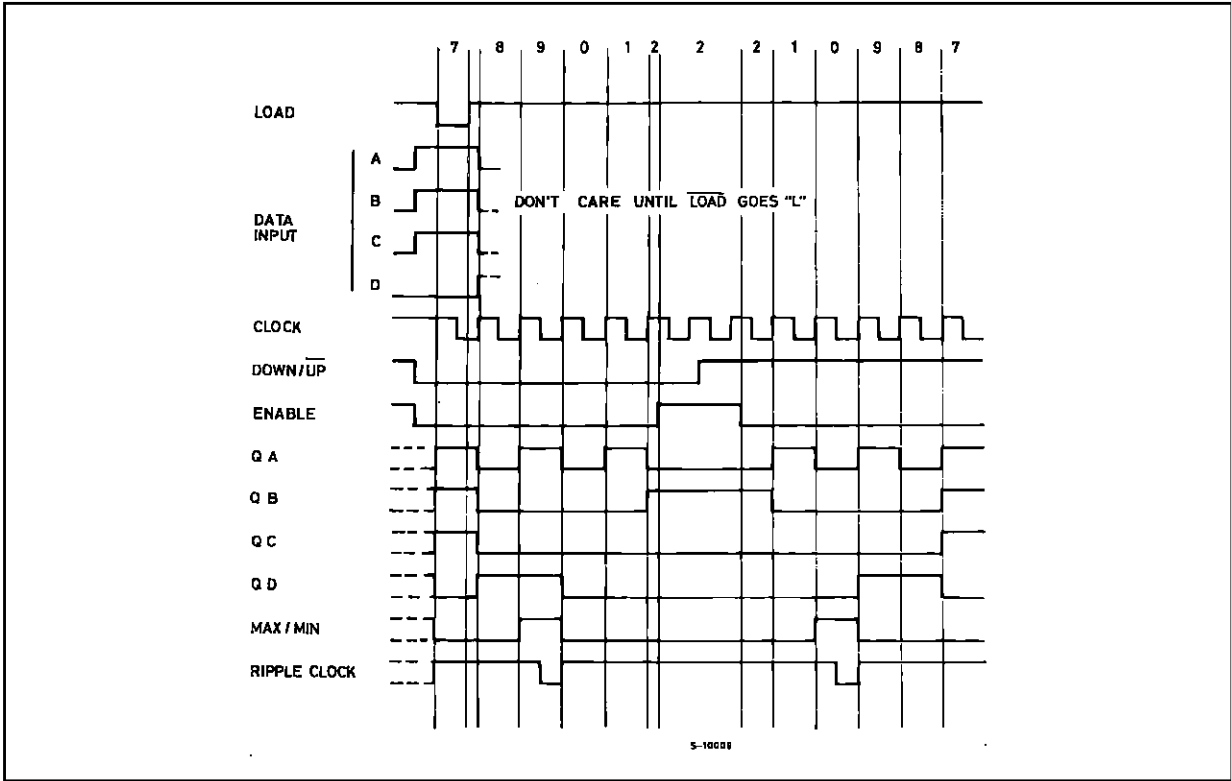

TIMING CHART (HC191)

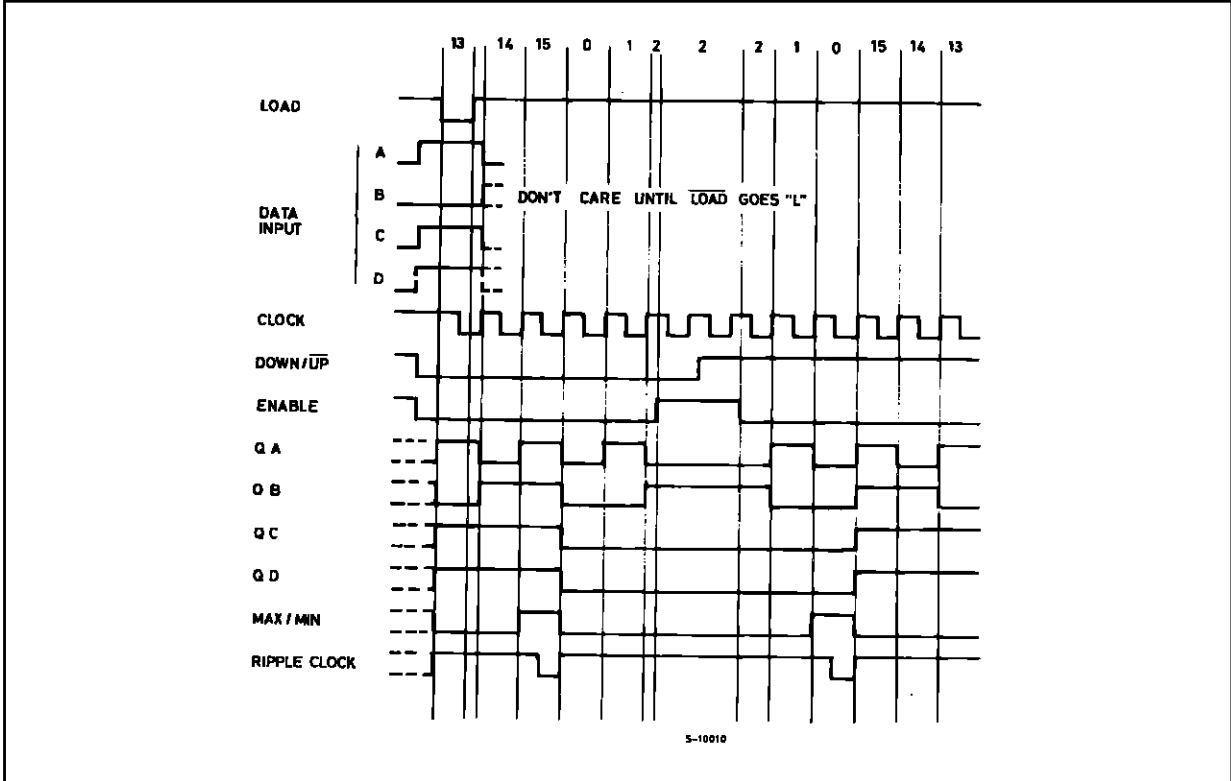

ABSOLUTE MAXIMUM RATINGS

Symbol	Parameter	Value	Unit
V _{CC}	Supply Voltage	-0.5 to +7	V
V _I	DC Input Voltage	-0.5 to V _{CC} + 0.5	V
V _O	DC Output Voltage	-0.5 to V _{CC} + 0.5	V
I _{IK}	DC Input Diode Current	± 20	mA
I _{OK}	DC Output Diode Current	± 20	mA
I _O	DC Output Source Sink Current Per Output Pin	± 25	mA
I _{CC} or I _{GND}	DC V _{CC} or Ground Current	± 50	mA
P _D	Power Dissipation	500 (*)	mW
T _{stg}	Storage Temperature	-65 to +150	°C
T _L	Lead Temperature (10 sec)	300	°C

Absolute Maximum Ratings are those values beyond which damage to the device may occur. Functional operation under these condition is not implied.

(*) 500 mW: ≡ 65 °C derate to 300 mW by 10mW/°C: 65 °C to 85 °C

RECOMMENDED OPERATING CONDITIONS

Symbol	Parameter	Value	Unit	
V _{CC}	Supply Voltage	2 to 6	V	
V _I	Input Voltage	0 to V _{CC}	V	
V _O	Output Voltage	0 to V _{CC}	V	
T _{op}	Operating Temperature: M54HC Series M74HC Series	-55 to +125 -40 to +85	°C °C	
t _r , t _f	Input Rise and Fall Time	V _{CC} = 2 V V _{CC} = 4.5 V V _{CC} = 6 V	0 to 1000 0 to 500 0 to 400	ns

DC SPECIFICATIONS

Symbol	Parameter	Test Conditions		Value						Unit		
		V _{CC} (V)		T _A = 25 °C 54HC and 74HC			-40 to 85 °C 74HC		-55 to 125 °C 54HC			
				Min.	Typ.	Max.	Min.	Max.	Min.		Max.	
V _{IH}	High Level Input Voltage	2.0		1.5			1.5		1.5		V	
		4.5		3.15			3.15		3.15			
		6.0		4.2			4.2		4.2			
V _{IL}	Low Level Input Voltage	2.0				0.5		0.5		0.5	V	
		4.5				1.35		1.35		1.35		
		6.0				1.8		1.8		1.8		
V _{OH}	High Level Output Voltage	2.0	V _I = V _{IH} or V _{IL}	I _O = -20 μA	1.9	2.0		1.9		1.9	V	
		4.5			4.4	4.5		4.4		4.4		
		6.0			5.9	6.0		5.9		5.9		
		4.5	I _O = -4.0 mA	4.18	4.31		4.13		4.10			
		6.0		I _O = -5.2 mA	5.68	5.8		5.63		5.60		
V _{OL}	Low Level Output Voltage	2.0	V _I = V _{IH} or V _{IL}	I _O = 20 μA		0.0	0.1		0.1		0.1	V
		4.5				0.0	0.1		0.1		0.1	
		6.0				0.0	0.1		0.1		0.1	
		4.5		I _O = 4.0 mA	0.17	0.26		0.33		0.40		
		6.0			I _O = 5.2 mA	0.18	0.26		0.33		0.40	
I _I	Input Leakage Current	6.0	V _I = V _{CC} or GND			±0.1		±1		±1	μA	
I _{CC}	Quiescent Supply Current	6.0	V _I = V _{CC} or GND			4		40		80	μA	

AC ELECTRICAL CHARACTERISTICS (C_L = 50 pF, Input t_r = t_f = 6 ns)

Symbol	Parameter	Test Conditions		Value						Unit	
		V _{CC} (V)		T _A = 25 °C 54HC and 74HC			-40 to 85 °C 74HC		-55 to 125 °C 54HC		
				Min.	Typ.	Max.	Min.	Max.	Min.		Max.
t _{TLH} t _{THL}	Output Transition Time	2.0			30	75		95		110	ns
		4.5			8	15		19		22	
		6.0			7	13		16		19	
t _{PLH} t _{PHL}	Propagation Delay Time (CLOCK - Q)	2.0			92	180		225		270	ns
		4.5			23	36		45		54	
		6.0			20	31		38		46	
t _{PLH} t _{PHL}	Propagation Delay Time (CLOCK - RCO)	2.0			39	120		150		180	ns
		4.5			13	24		30		36	
		6.0			11	20		26		31	
t _{PLH} t _{PHL}	Propagation Delay Time (CLOCK - MAX/MIN)	2.0			120	240		300		360	ns
		4.5			30	48		60		72	
		6.0			26	41		51		61	
t _{PLH} t _{PHL}	Propagation Delay Time (LOAD - Q)	2.0			108	205		255		310	ns
		4.5			27	41		51		62	
		6.0			23	35		43		53	

M54/M74HC190/191

AC ELECTRICAL CHARACTERISTICS (C_L = 50 pF, Input t_r = t_f = 6 ns)

Symbol	Parameter	Test Conditions		Value						Unit	
		V _{CC} (V)		T _A = 25 °C 54HC and 74HC			-40 to 85 °C 74HC		-55 to 125 °C 54HC		
				Min.	Typ.	Max.	Min.	Max.	Min.		Max.
t _{PLH} t _{PHL}	Propagation Delay Time (DATA - Q)	2.0			84	175		220		265	ns
		4.5			21	35		44		53	
		6.0			18	30		37		45	
t _{PLH} t _{PHL}	Propagation Delay Time (ENABLE - RCO)	2.0			39	105		130		160	ns
		4.5			13	21		26		32	
		6.0			11	18		22		27	
t _{PLH} t _{PHL}	Propagation Delay Time (D/U - RCO)	2.0			63	180		225		270	ns
		4.5			21	36		45		54	
		6.0			18	31		38		46	
t _{PLH} t _{PHL}	Propagation Delay Time (D/U - MAX/MIN)	2.0			64	160		200		240	ns
		4.5			18	32		40		48	
		6.0			15	27		34		41	
f _{MAX}	Maximum Clock Frequency	2.0			5	9		4		3.4	MHz
		4.5			25	37		20		17	
		6.0			30	44		24		20	
t _{W(H)} t _{W(L)}	Minimum Pulse Width (CLOCK)	2.0			40	100		125		150	ns
		4.5			10	20		25		30	
		6.0			9	17		21		26	
t _{W(L)}	Minimum Pulse Width (LOAD)	2.0			36	75		95		110	ns
		4.5			9	15		19		22	
		6.0			8	13		16		19	
t _s	Minimum Set-up Time (SI, PI - CK)	2.0			80	175		220		265	ns
		4.5			20	35		44		53	
		6.0			17	30		37		45	
t _s	Minimum Set-up Time (S0, S1 - CK)	2.0			16	50		60		75	ns
		4.5			4	10		12		15	
		6.0			3	9		11		13	
t _h	Minimum Hold Time	2.0				0		0		0	ns
		4.5				0		0		0	
		6.0				0		0		0	
t _{REM}	Minimum Removal Time	2.0			12	50		60		5	ns
		4.5			3	10		12		15	
		6.0			3	9		11		13	
C _{IN}	Input Capacitance				5	10		10		10	pF
C _{PD} (*)	Power Dissipation Capacitance		for HC190 for HC191		111 112						pF

(*) C_{PD} is defined as the value of the IC's internal equivalent capacitance which is calculated from the operating current consumption without load. (Refer to Test Circuit). Average operating current can be obtained by the following equation. I_{CC(opr)} = C_{PD} • V_{CC} • f_{IN} + I_{CC}

SWITCHING CHARACTERISTICS TEST WAVEFORM

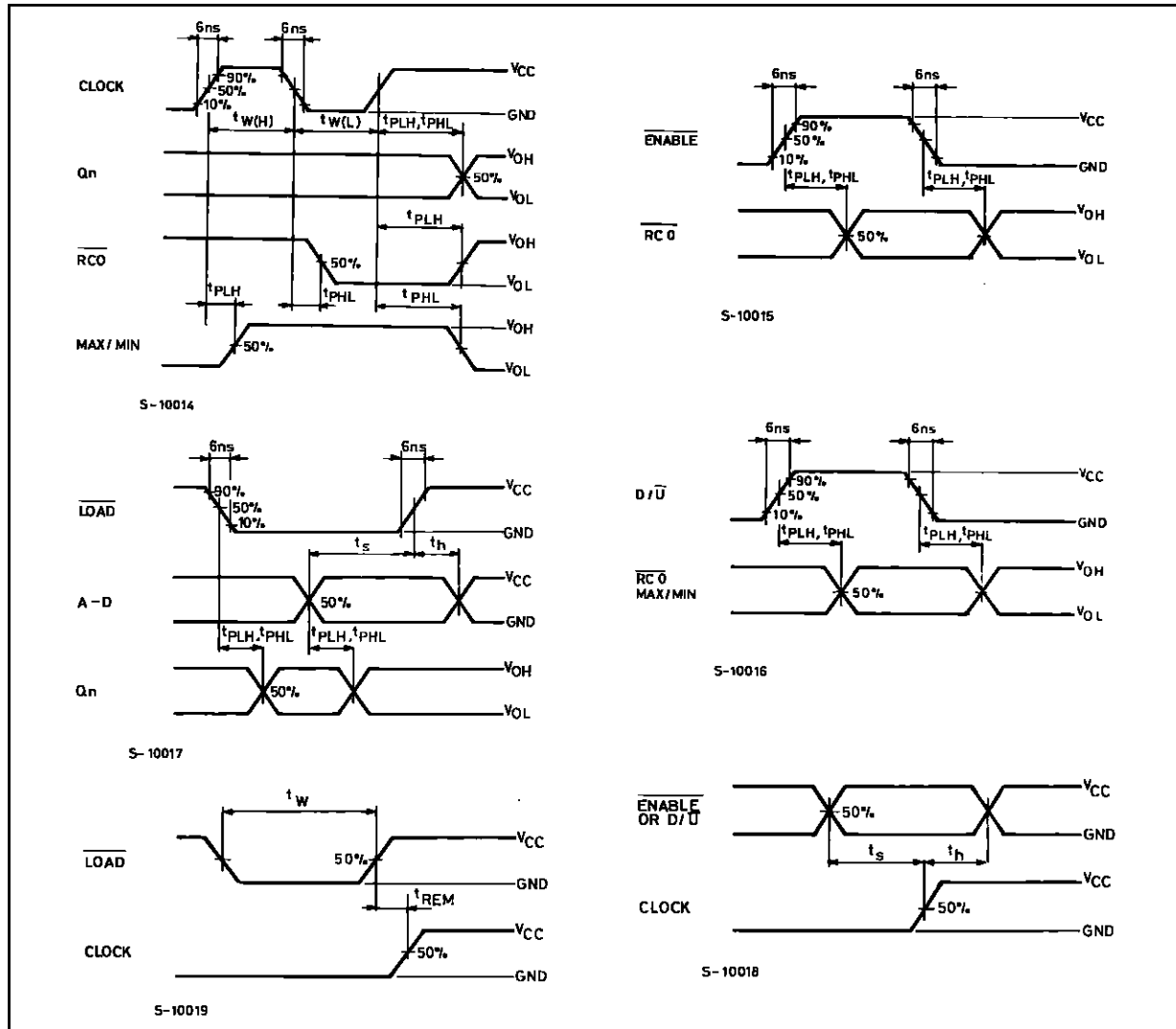

TEST CIRCUIT I_{CC} (Opr.)

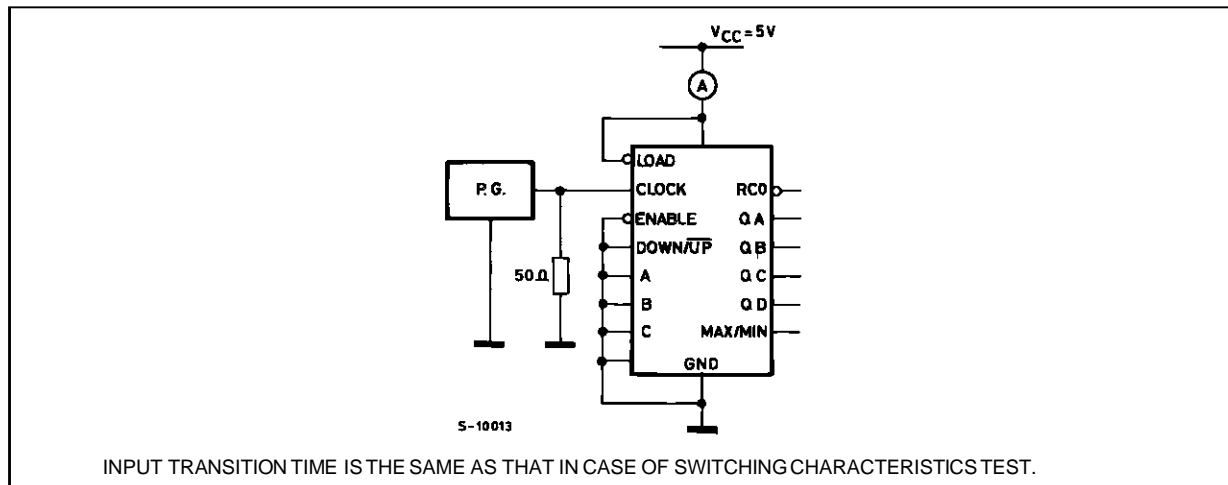

INPUT TRANSITION TIME IS THE SAME AS THAT IN CASE OF SWITCHING CHARACTERISTICS TEST.

Plastic DIP16 (0.25) MECHANICAL DATA

DIM.	mm			inch		
	MIN.	TYP.	MAX.	MIN.	TYP.	MAX.
a1	0.51			0.020		
B	0.77		1.65	0.030		0.065
b		0.5			0.020	
b1		0.25			0.010	
D			20			0.787
E		8.5			0.335	
e		2.54			0.100	
e3		17.78			0.700	
F			7.1			0.280
I			5.1			0.201
L		3.3			0.130	
Z			1.27			0.050

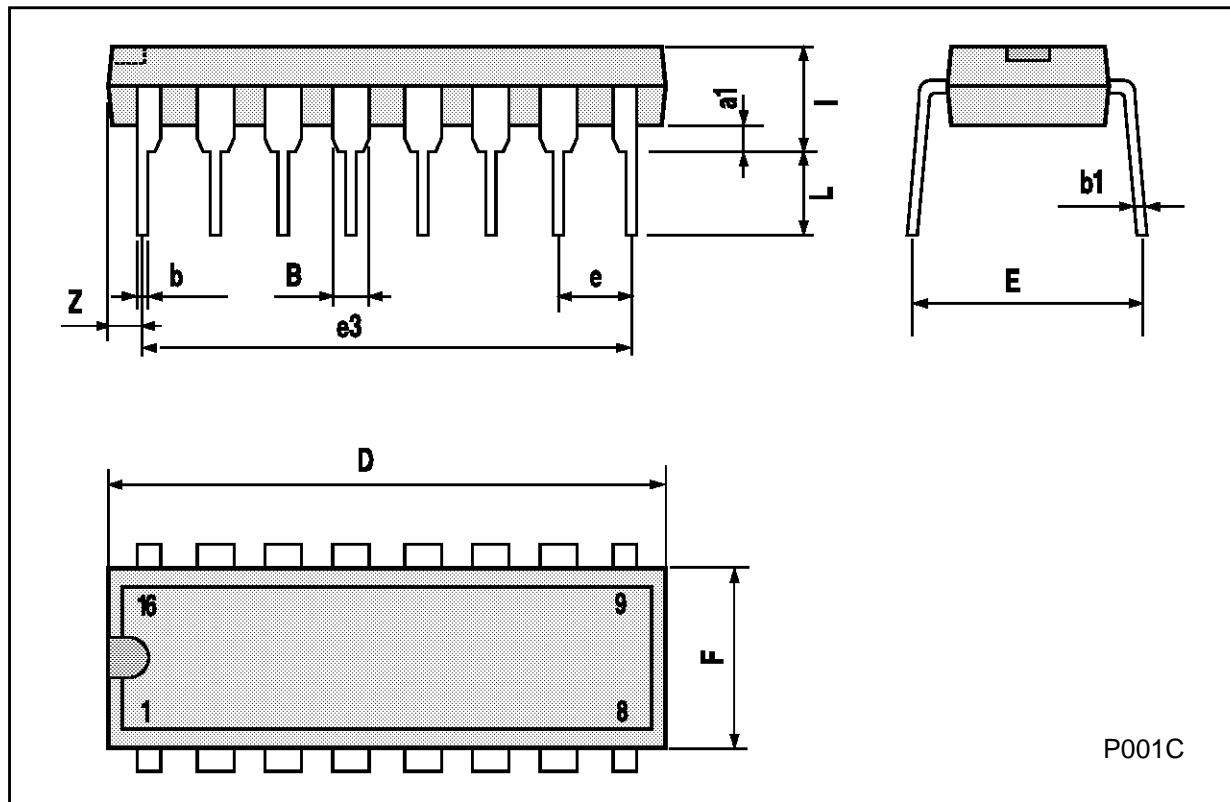

P001C

Ceramic DIP16/1 MECHANICAL DATA

DIM.	mm			inch		
	MIN.	TYP.	MAX.	MIN.	TYP.	MAX.
A			20			0.787
B			7			0.276
D		3.3			0.130	
E	0.38			0.015		
e3		17.78			0.700	
F	2.29		2.79	0.090		0.110
G	0.4		0.55	0.016		0.022
H	1.17		1.52	0.046		0.060
L	0.22		0.31	0.009		0.012
M	0.51		1.27	0.020		0.050
N			10.3			0.406
P	7.8		8.05	0.307		0.317
Q			5.08			0.200

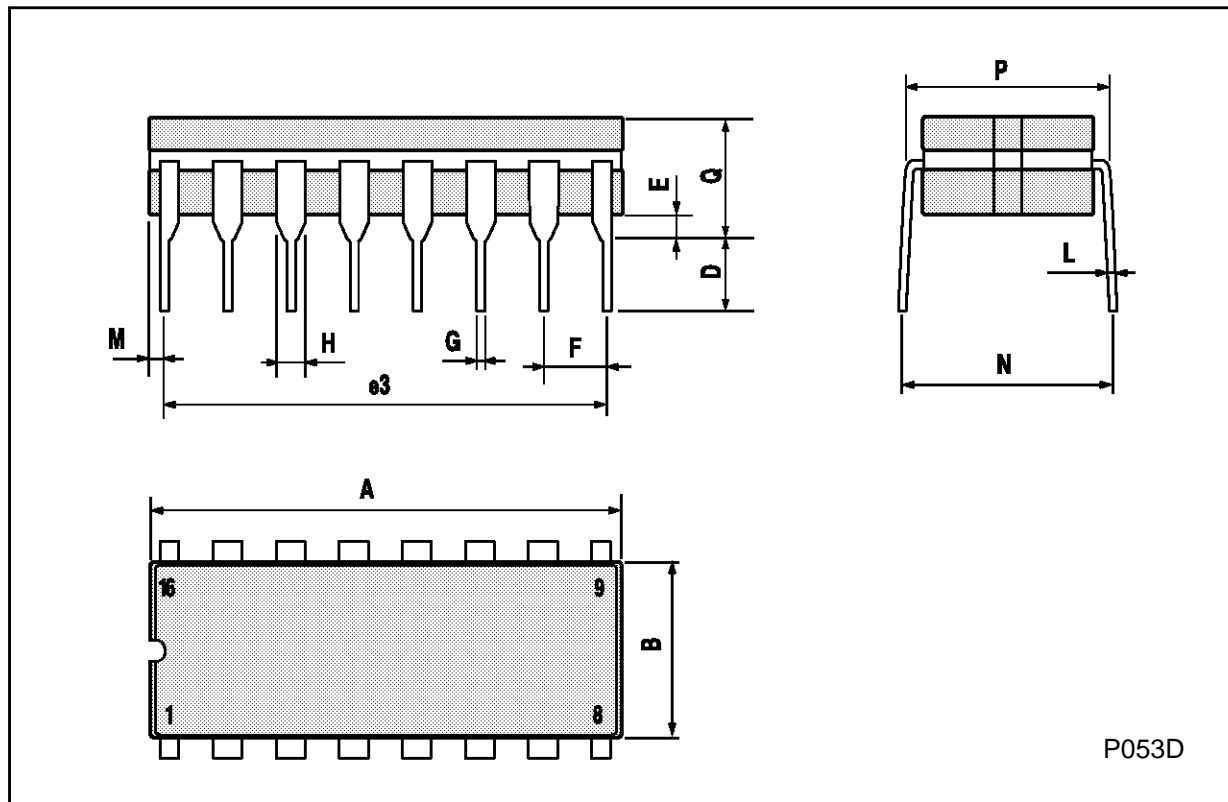

SO16 (Narrow) MECHANICAL DATA

DIM.	mm			inch		
	MIN.	TYP.	MAX.	MIN.	TYP.	MAX.
A			1.75			0.068
a1	0.1		0.2	0.004		0.007
a2			1.65			0.064
b	0.35		0.46	0.013		0.018
b1	0.19		0.25	0.007		0.010
C		0.5			0.019	
c1	45° (typ.)					
D	9.8		10	0.385		0.393
E	5.8		6.2	0.228		0.244
e		1.27			0.050	
e3		8.89			0.350	
F	3.8		4.0	0.149		0.157
G	4.6		5.3	0.181		0.208
L	0.5		1.27	0.019		0.050
M			0.62			0.024
S	8° (max.)					

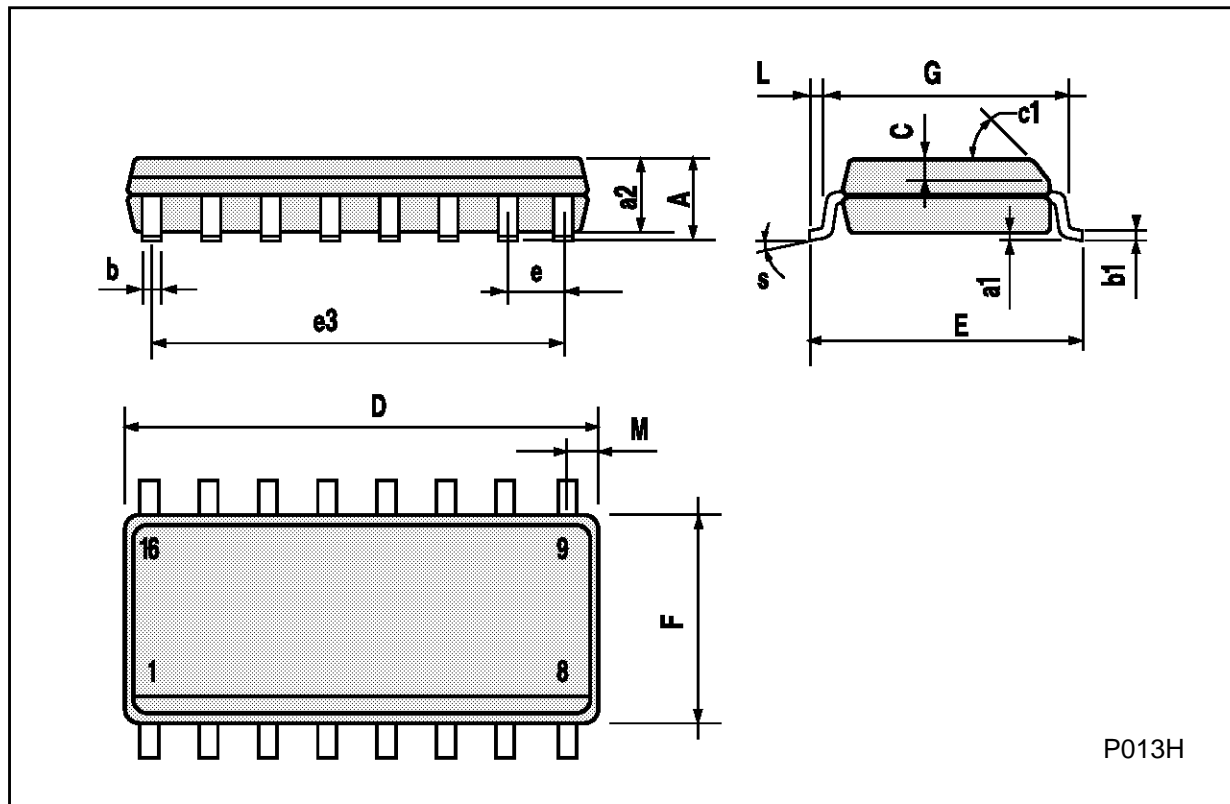

P013H

PLCC20 MECHANICAL DATA

DIM.	mm			inch		
	MIN.	TYP.	MAX.	MIN.	TYP.	MAX.
A	9.78		10.03	0.385		0.395
B	8.89		9.04	0.350		0.356
D	4.2		4.57	0.165		0.180
d1		2.54			0.100	
d2		0.56			0.022	
E	7.37		8.38	0.290		0.330
e		1.27			0.050	
e3		5.08			0.200	
F		0.38			0.015	
G			0.101			0.004
M		1.27			0.050	
M1		1.14			0.045	

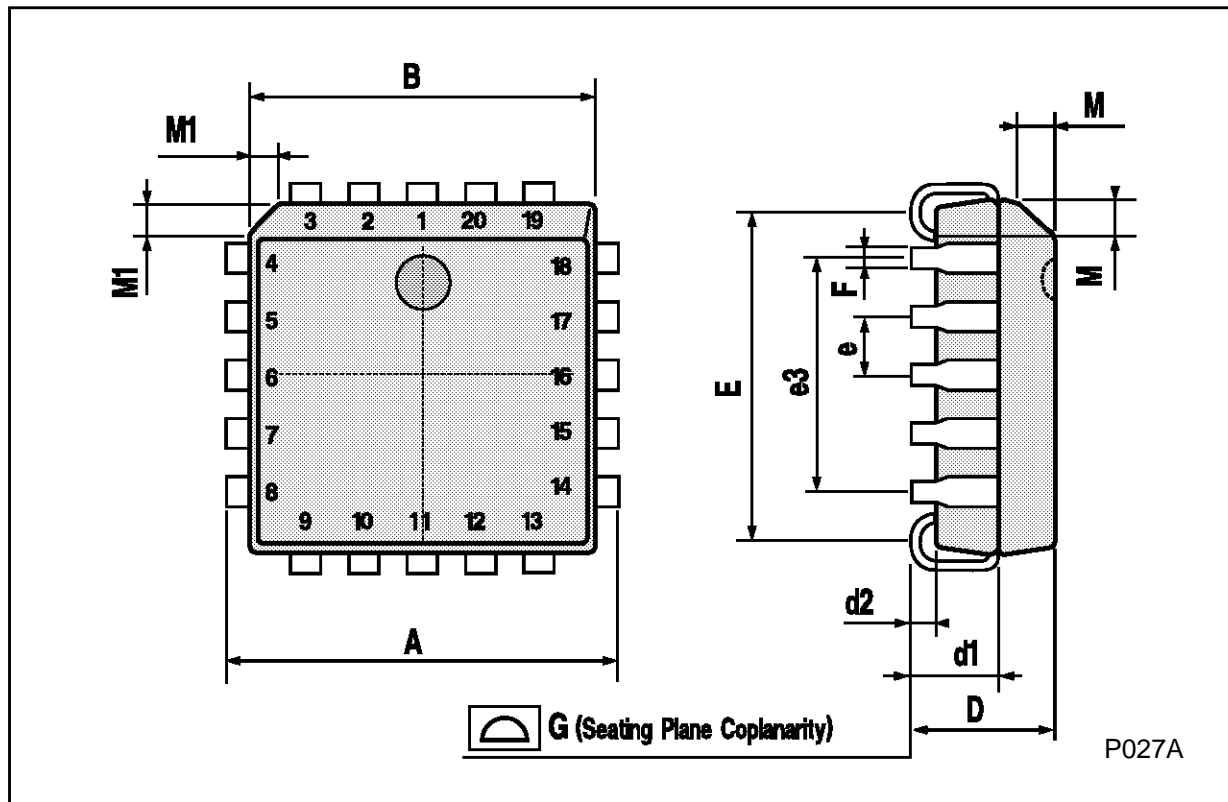

Information furnished is believed to be accurate and reliable. However, SGS-THOMSON Microelectronics assumes no responsibility for the consequences of use of such information nor for any infringement of patents or other rights of third parties which may result from its use. No license is granted by implication or otherwise under any patent or patent rights of SGS-THOMSON Microelectronics. Specifications mentioned in this publication are subject to change without notice. This publication supersedes and replaces all information previously supplied. SGS-THOMSON Microelectronics products are not authorized for use as critical components in life support devices or systems without express written approval of SGS-THOMSON Microelectronics.

© 1994 SGS-THOMSON Microelectronics - All Rights Reserved

SGS-THOMSON Microelectronics GROUP OF COMPANIES

Australia - Brazil - France - Germany - Hong Kong - Italy - Japan - Korea - Malaysia - Malta - Morocco - The Netherlands -
Singapore - Spain - Sweden - Switzerland - Taiwan - Thailand - United Kingdom - U.S.A