

LM4041

Precision Micropower Shunt Voltage Reference

General Description

Ideal for space critical applications, the LM4041 precision voltage reference is available in the sub-miniature (3 mm x 1.3 mm) SOT-23 surface-mount package. The LM4041's advanced design eliminates the need for an external stabilizing capacitor while ensuring stability with any capacitive load, thus making the LM4041 easy to use. Further reducing design effort is the availability of a fixed (1.225V) and adjustable reverse breakdown voltage. The minimum operating current is 60 μ A for the LM4041-1.2 and the LM4041-ADJ. Both versions have a maximum operating current of 12 mA.

The LM4041 utilizes fuse and zener-zap reverse breakdown or reference voltage trim during wafer sort to ensure that the prime parts have an accuracy of better than $\pm 0.1\%$ (A grade) at 25°C. Bandgap reference temperature drift curvature correction and low dynamic impedance ensure stable reverse breakdown voltage accuracy over a wide range of operating temperatures and currents.

Features

- Small packages: SOT-23, TO-92, and SO-8
- No output capacitor required
- Tolerates capacitive loads

- Reverse breakdown voltage options of 1.225V and adjustable
- Contact National Semiconductor Analog Marketing for parts with extended temperature range

Key Specifications (LM4041-1.2)

- Output voltage tolerance (A grade, 25°C) $\pm 0.1\%$ (max)
- Low output noise (10 Hz to 10 kHz) 20 μ V_{rms} (typ)
- Wide operating current range 60 μ A to 12 mA
- Industrial temperature range -40°C to +85°C
- Low temperature coefficient 100 ppm/°C (max)

Applications

- Portable, Battery-Powered Equipment
- Data Acquisition Systems
- Instrumentation
- Process Control
- Energy Management
- Product Testing
- Automotive
- Precision Audio Components

Connection Diagrams

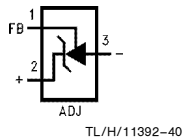
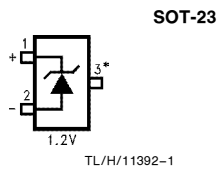

*This pin must be left floating or connected to pin 2.

Top View

See NS Package Number M03B
(JEDEC Registration TO-236AB)

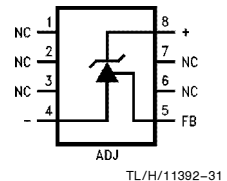
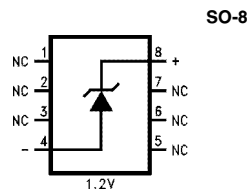

Top View

See NS Package Number M08A

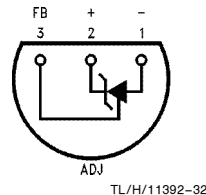
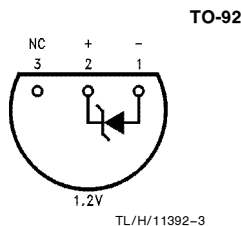

Bottom View

See NS Package Number Z03A

Ordering Information

Reverse Breakdown Voltage Tolerance at 25°C and Average Reverse Breakdown Voltage Temperature Coefficient	Package		
	M3 (SOT-23)	Z (TO-92)	M (SO-8)
± 0.1%, 100 ppm/°C max (A grade)	LM4041AIM3-1.2 See NS Package Number M03B	LM4041AIZ-1.2 See NS Package Number Z03A	LM4041AIM-1.2 See NS Package Number M08A
± 0.2%, 100 ppm/°C max (B grade)	LM4041BIM3-1.2 See NS Package Number M03B	LM4041BIZ-1.2 See NS Package Number Z03A	LM4041BIM-1.2 See NS Package Number M08A
± 0.5%, 100 ppm/°C max (C grade)	LM4041CIM3-1.2 LM4041CIM3-ADJ See NS Package Number M03B	LM4041CIZ-1.2, LM4041CIZ-ADJ See NS Package Number Z03A	LM4041CIM-1.2, LM4041CIM-ADJ See NS Package Number M08A
± 1.0%, 150 ppm/°C max (D grade)	LM4041DIM3-1.2 LM4041DIM3-ADJ See NS Package Number M03B	LM4041DIZ-1.2, LM4041DIZ-ADJ See NS Package Number Z03A	LM4041DIM-1.2, LM4041DIM-ADJ See NS Package Number M08A
± 2.0%, 150 ppm/°C max (E grade)	LM4041EIM3-1.2 See NS Package Number M03B	LM4041EIZ-1.2 See NS Package Number Z03A	

SOT-23 Package Marking Information

Only three fields of marking are possible on the SOT-23's small surface. This table gives the meaning of the three fields.

Part Marking	Field Definition
R1A R1B R1C R1D R1E	First Field: R = Reference Second Field: 1 = 1.225V Voltage Option A = Adjustable Third Field:
RAC RAD	A-E = Initial Reverse Breakdown Voltage or Reference Voltage Tolerance A = ± 0.1%, B = ± 0.2%, C = ± 0.5%, D = ± 1.0%, E = ± 2.0%

Absolute Maximum Ratings (Note 1)

If Military/Aerospace specified devices are required, please contact the National Semiconductor Sales Office/Distributors for availability and specifications.

Reverse Current	20 mA
Forward Current	10 mA
Maximum Output Voltage (LM4041-ADJ)	15V
Power Dissipation ($T_A = 25^\circ\text{C}$) (Note 2)	
M Package	540 mW
M3 Package	306 mW
Z Package	550 mW
Storage Temperature	-65°C to $+150^\circ\text{C}$
Lead Temperature	
M and M3 Packages	
Vapor phase (60 seconds)	$+215^\circ\text{C}$
Infrared (15 seconds)	$+220^\circ\text{C}$
Z Package	
Soldering (10 seconds)	$+260^\circ\text{C}$

ESD Susceptibility

Human Body Model (Note 3)	2 kV
Machine Model (Note 3)	200V

See AN-450 "Surface Mounting Methods and Their Effect on Product Reliability" for other methods of soldering surface mount devices.

Operating Ratings (Notes 1 & 2)

Temperature Range ($T_{\min} \leq T_A \leq T_{\max}$)	$-40^\circ\text{C} \leq T_A \leq +85^\circ\text{C}$
Reverse Current	
LM4041-1.2	60 μA to 12 mA
LM4041-ADJ	60 μA to 12 mA
Output Voltage Range	
LM4041-ADJ	1.24V to 10V

LM4041-1.2

Electrical Characteristics

Boldface limits apply for $T_A = T_J = T_{\min}$ to T_{\max} ; all other limits $T_A = T_J = 25^\circ\text{C}$. The grades A and B designate initial Reverse Breakdown Voltage tolerances of $\pm 0.1\%$ and $\pm 0.2\%$, respectively.

Symbol	Parameter	Conditions	Typical (Note 4)	LM4041AIM LM4041AIM3 LM4041AIZ Limits (Note 5)	LM4041BIM LM4041BIM3 LM4041BIZ Limits (Note 5)	Units (Limit)
V_R	Reverse Breakdown Voltage	$I_R = 100 \mu\text{A}$	1.225			V
	Reverse Breakdown Voltage Tolerance (Note 6)	$I_R = 100 \mu\text{A}$		± 1.2 ± 9.2	± 2.4 ± 10.4	mV (max) mV (max)
$I_{R\min}$	Minimum Operating Current		45	60 65	60 65	μA μA (max) μA (max)
$\Delta V_R/\Delta T$	Average Reverse Breakdown Voltage Temperature Coefficient	$I_R = 10 \text{ mA}$ $I_R = 1 \text{ mA}$ $I_R = 100 \mu\text{A}$	± 20 ± 15 ± 15	± 100	± 100	ppm/ $^\circ\text{C}$ ppm/ $^\circ\text{C}$ (max) ppm/ $^\circ\text{C}$
$\Delta V_R/\Delta I_R$	Reverse Breakdown Voltage Change with Operating Current Change	$I_{R\min} \leq I_R \leq 1 \text{ mA}$	0.7	1.5 2.0	1.5 2.0	mV mV (max) mV (max)
		$1 \text{ mA} \leq I_R \leq 12 \text{ mA}$	4.0	6.0 8.0	6.0 8.0	mV mV (max) mV (max)
Z_R	Reverse Dynamic Impedance	$I_R = 1 \text{ mA}$, $f = 120 \text{ Hz}$, $I_{AC} = 0.1 I_R$	0.5	1.5	1.5	Ω Ω (max)
e_N	Wideband Noise	$I_R = 100 \mu\text{A}$ $10 \text{ Hz} \leq f \leq 10 \text{ kHz}$	20			μV_{rms}
ΔV_R	Reverse Breakdown Voltage Long Term Stability	$t = 1000 \text{ hrs}$ $T = 25^\circ\text{C} \pm 0.1^\circ\text{C}$ $I_R = 100 \mu\text{A}$	120			ppm

LM4041-1.2 (Continued)

Electrical Characteristics (Continued)

Boldface limits apply for $T_A = T_J = T_{MIN}$ to T_{MAX} ; all other limits $T_A = T_J = 25^\circ\text{C}$. The grades C, D and E designate initial Reverse Breakdown Voltage tolerances of $\pm 0.5\%$, $\pm 1.0\%$ and $\pm 2.0\%$, respectively.

Symbol	Parameter	Conditions	Typical (Note 4)	LM4041CIM	LM4041DIM	LM4041EIM3	Units (Limit)
				LM4041CIM3 LM4041CIZ Limits (Note 5)	LM4041DIM3 LM4041DIZ Limits (Note 5)	LM4041EIZ Limits (Note 5)	
V_R	Reverse Breakdown Voltage	$I_R = 100 \mu\text{A}$	1.225				V
	Reverse Breakdown Voltage Tolerance (Note 6)	$I_R = 100 \mu\text{A}$		± 6 ± 14	± 12 ± 24	± 25 ± 36	mV (max) mV (max)
I_{RMIN}	Minimum Operating Current		45	60 65	65 70	65 70	μA μA (max) μA (max)
$\Delta V_R/\Delta T$	Average Reverse Breakdown Voltage Temperature Coefficient	$I_R = 10 \text{ mA}$ $I_R = 1 \text{ mA}$ $I_R = 100 \mu\text{A}$	± 20 ± 15 ± 15	± 100	± 150	± 150	ppm/ $^\circ\text{C}$ ppm/ $^\circ\text{C}$ (max) ppm/ $^\circ\text{C}$
$\Delta V_R/\Delta I_R$	Reverse Breakdown Voltage Change with Operating Current Change	$I_{RMIN} \leq I_R \leq 1 \text{ mA}$	0.7	1.5 2.0	2.0 25	2.0 2.5	mV mV (max) mV (max)
		$1 \text{ mA} \leq I_R \leq 12 \text{ mA}$	2.5	6.0 8.0	8.0 10.0	8.0 10.0	mV mV (max) mV (max)
Z_R	Reverse Dynamic Impedance	$I_R = 1 \text{ mA}$, $f = 120 \text{ Hz}$ $I_{AC} = 0.1 I_R$	0.5	1.5	2.0	2.0	Ω Ω (max)
e_N	Wideband Noise	$I_R = 100 \mu\text{A}$ $10 \text{ Hz} \leq f \leq 10 \text{ kHz}$	20				μV_{rms}
ΔV_R	Reverse Breakdown Voltage Long Term Stability	$t = 1000 \text{ hrs}$ $T = 25^\circ\text{C} \pm 0.1^\circ\text{C}$ $I_R = 100 \mu\text{A}$	120				ppm

LM4041-ADJ (Adjustable)

Electrical Characteristics

Boldface limits apply for $T_A = T_J = T_{MIN}$ to T_{MAX} ; all other limits $T_J = 25^\circ\text{C}$ unless otherwise specified (SOT-23, see Note 7), $I_{RMIN} \leq I_R \leq 12 \text{ mA}$, $V_{REF} \leq V_{OUT} \leq 10\text{V}$. The grades C and D designates initial Reference Voltage Tolerances of $\pm 0.5\%$ and $\pm 1\%$, respectively for $V_{OUT} = 5\text{V}$.

Symbol	Parameter	Conditions	Typical (Note 4)	LM4041CIM	LM4041DIM	Units (Limit)
				LM4041CIM3 LM4041CIZ (Note 5)	LM4041DIM3 LM4041DIZ (Note 5)	
V_{REF}	Reference Voltage	$I_R = 100 \mu\text{A}$, $V_{OUT} = 5\text{V}$	1.233			V
	Reference Voltage Tolerance (Note 8)	$I_R = 100 \mu\text{A}$, $V_{OUT} = 5\text{V}$		± 6.2 ± 14	± 12 ± 24	mV (max) mV (max)
I_{RMIN}	Minimum Operating Current		45	60 65	65 70	μA μA (max) μA (max)

LM4041-ADJ (Adjustable) (Continued)

Electrical Characteristics (Continued)

Boldface limits apply for $T_A = T_J = T_{MIN}$ to T_{MAX} ; all other limits $T_J = 25^\circ\text{C}$ unless otherwise specified (SOT-23, see Note 7), $I_{RMIN} \leq I_R \leq 12\text{ mA}$, $V_{REF} \leq V_{OUT} \leq 10\text{ V}$. The grades C and D designates initial Reference Voltage Tolerances of $\pm 0.5\%$ and $\pm 1\%$, respectively for $V_{OUT} = 5\text{ V}$.

Symbol	Parameter	Conditions	Typical (Note 4)	LM4041CIM LM4041CIM3 LM4041CIZ (Note 5)	LM4041DIM LM4041DIM3 LM4041DIZ (Note 5)	Units (Limit)
$\Delta V_{REF}/\Delta I_R$	Reference Voltage Change with Operating Current Change	$I_{RMIN} \leq I_R \leq 1\text{ mA}$ SOT-23: $V_{OUT} \geq 1.6\text{ V}$ (Note 7)	0.7	1.5 2.0	2.0 2.5	mV mV (max) mV (max)
		$1\text{ mA} \leq I_R \leq 12\text{ mA}$ SOT-23: $V_{OUT} \geq 1.6\text{ V}$ (Note 7)	2	4 6	6 8	mV mV (max) mV (max)
$\Delta V_{REF}/\Delta V_O$	Reference Voltage Change with Output Voltage Change	$I_R = 1\text{ mA}$	-1.3	-2.0 -2.5	-2.5 -3.0	mV/V mV/V (max) mV/V (max)
I_{FB}	Feedback Current		60	100 120	150 200	nA nA (max) nA (max)
$\Delta V_{REF}/\Delta T$	Average Reference Voltage Temperature Coefficient (Note 8)	$V_{OUT} = 5\text{ V}$, $I_R = 10\text{ mA}$	20	± 100	± 150	ppm/ $^\circ\text{C}$ ppm/ $^\circ\text{C}$ (max) ppm/ $^\circ\text{C}$
		$I_R = 1\text{ mA}$	15			
		$I_R = 100\text{ }\mu\text{A}$	15			
Z_{OUT}	Dynamic Output Impedance	$I_R = 1\text{ mA}$, $f = 120\text{ Hz}$, $I_{AC} = 0.1 I_R$ $V_{OUT} = V_{REF}$ $V_{OUT} = 10\text{ V}$	0.3			Ω
			2			Ω
e_N	Wideband Noise	$I_R = 100\text{ }\mu\text{A}$, $V_{OUT} = V_{REF}$ $10\text{ Hz} \leq f \leq 10\text{ kHz}$	20			μV_{rms}
ΔV_{REF}	Reference Voltage Long Term Stability	$t = 1000\text{ hrs}$, $I_R = 100\text{ }\mu\text{A}$ $T = 25^\circ\text{C} \pm 0.1^\circ\text{C}$	120			ppm

Note 1: Absolute Maximum Ratings indicate limits beyond which damage to the device may occur. Operating Ratings indicate conditions for which the device is functional, but do not guarantee specific performance limits. For guaranteed specifications and test conditions, see the Electrical Characteristics. The guaranteed specifications apply only for the test conditions listed. Some performance characteristics may degrade when the device is not operated under the listed test conditions.

Note 2: The maximum power dissipation must be derated at elevated temperatures and is dictated by T_{Jmax} (maximum junction temperature), θ_{JA} (junction to ambient thermal resistance), and T_A (ambient temperature). The maximum allowable power dissipation at any temperature is $P_{Dmax} = (T_{Jmax} - T_A)/\theta_{JA}$ or the number given in the Absolute Maximum Ratings, whichever is lower. For the LM4041, $T_{Jmax} = 125^\circ\text{C}$, and the typical thermal resistance (θ_{JA}), when board mounted, is 185°C/W for the M package, 326°C/W for the SOT-23 package, and 180°C/W with $0.4''$ lead length and 170°C/W with $0.125''$ lead length for the TO-92 package.

Note 3: The human body model is a 100 pF capacitor discharged through a $1.5\text{ k}\Omega$ resistor into each pin. The machine model is a 200 pF capacitor discharged directly into each pin.

Note 4: Typical values are at $T_J = 25^\circ\text{C}$ and represent most likely parametric norm.

Note 5: Limits are 100% production tested at 25°C . Limits over temperature are guaranteed through correlation using Statistical Quality Control (SQC) methods. The limits are used to calculate National's AOQL.

Note 6: The boldface (over-temperature) limit for Reverse Breakdown Voltage Tolerance is defined as the room temperature Reverse Breakdown Voltage Tolerance $\pm [(\Delta V_R/\Delta T)(65^\circ\text{C})(V_R)]$. $\Delta V_R/\Delta T$ is the V_R temperature coefficient, 65°C is the temperature range from -40°C to the reference point of 25°C , and V_R is the reverse breakdown voltage. The total over-temperature tolerance for the different grades is shown below:

A-grade: $\pm 0.75\% = \pm 0.1\% \pm 100\text{ ppm}/^\circ\text{C} \times 65^\circ\text{C}$

B-grade: $\pm 0.85\% = \pm 0.2\% \pm 100\text{ ppm}/^\circ\text{C} \times 65^\circ\text{C}$

C-grade: $\pm 1.15\% = \pm 0.5\% \pm 100\text{ ppm}/^\circ\text{C} \times 65^\circ\text{C}$

D-grade: $\pm 1.98\% = \pm 1.0\% \pm 150\text{ ppm}/^\circ\text{C} \times 65^\circ\text{C}$

E-grade: $\pm 2.98\% = \pm 2.0\% \pm 150\text{ ppm}/^\circ\text{C} \times 65^\circ\text{C}$

Therefore, as an example, the A-grade LM4041-1.2 has an over-temperature Reverse Breakdown Voltage tolerance of $\pm 1.2\text{ V} \times 0.75\% = \pm 9.2\text{ mV}$.

Note 7: When $V_{OUT} \leq 1.6\text{ V}$, the LM4041-ADJ in the SOT-23 package must operate at reduced I_R . This is caused by the series resistance of the die attach between the die (-) output and the package (-) output pin. See the Output Saturation (SOT-23 only) curve in the Typical Performance Characteristics section.

Note 8: Reference voltage and temperature coefficient will change with output voltage. See Typical Performance Characteristics curves.

Typical Performance Characteristics

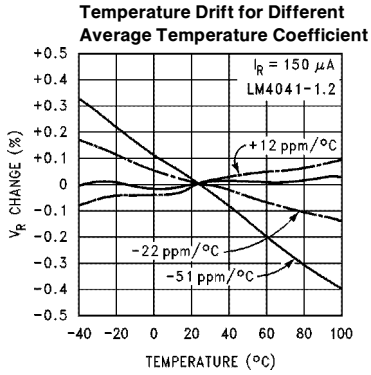

TL/H/11392-19

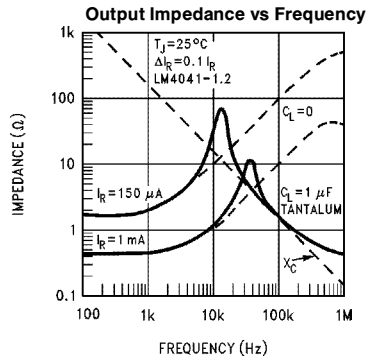

TL/H/11392-4

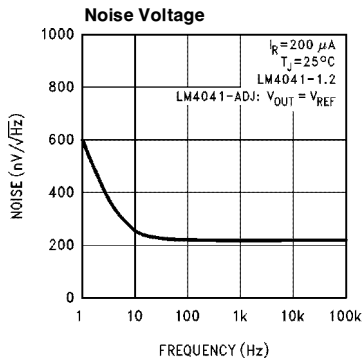

TL/H/11392-5

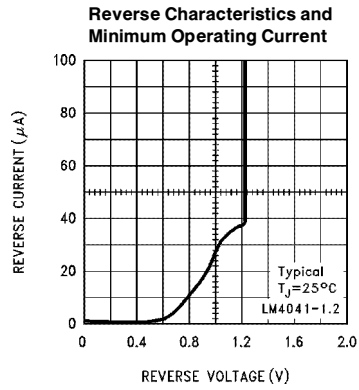

TL/H/11392-9

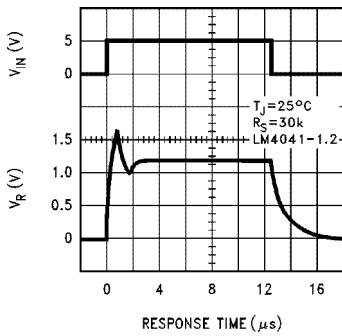

TL/H/11392-7

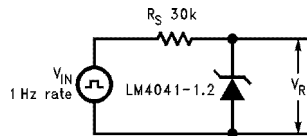

TL/H/11392-8

Typical Performance Characteristics (Continued)

Reference Voltage vs Output Voltage and Temperature

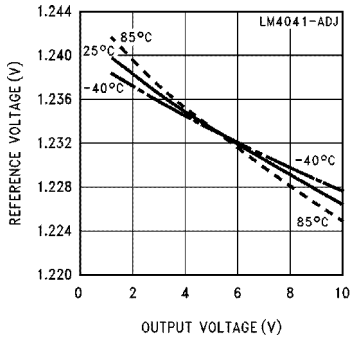

TL/H/11392-11

Reference Voltage vs Temperature and Output Voltage

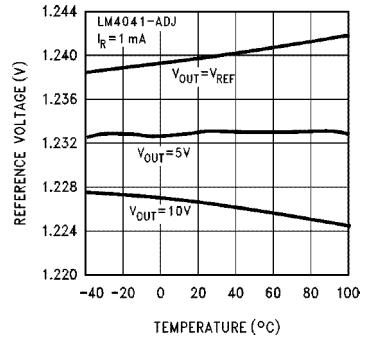

TL/H/11392-10

Feedback Current vs Output Voltage and Temperature

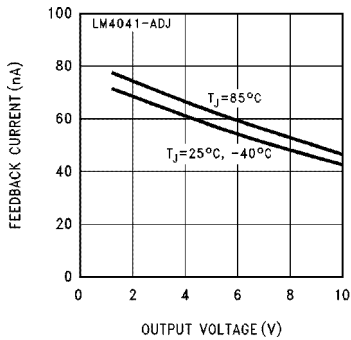

TL/H/11392-12

Output Saturation (SOT-23 Only)

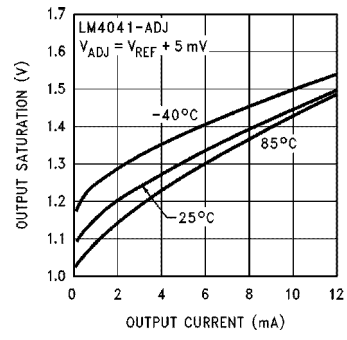

TL/H/11392-33

Output Impedance vs Frequency

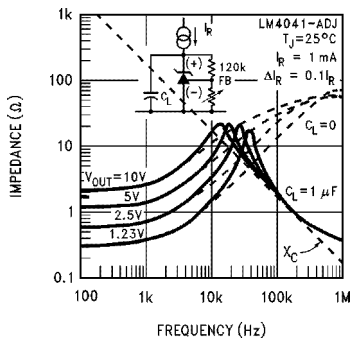

TL/H/11392-13

Output Impedance vs Frequency

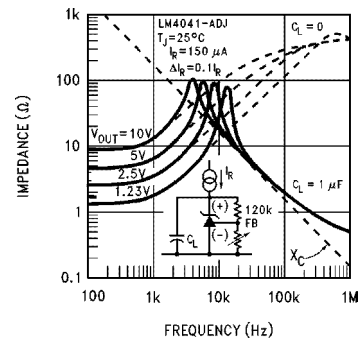

TL/H/11392-14

Typical Performance Characteristics (Continued)

Reverse Characteristics

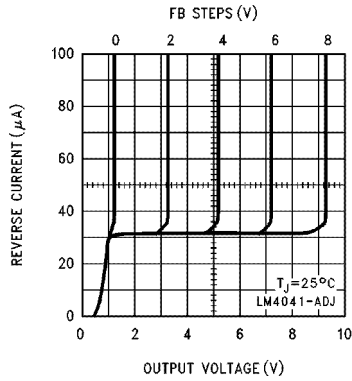

TL/H/11392-15

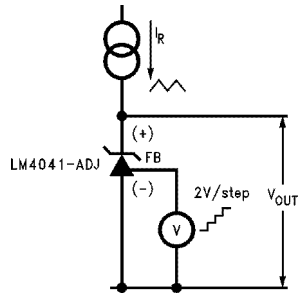

TL/H/11392-16

Large Signal Response

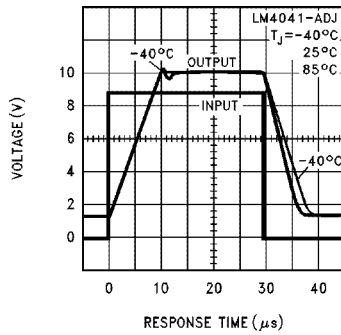

TL/H/11392-17

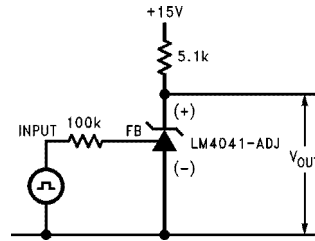

TL/H/11392-18

Functional Block Diagram

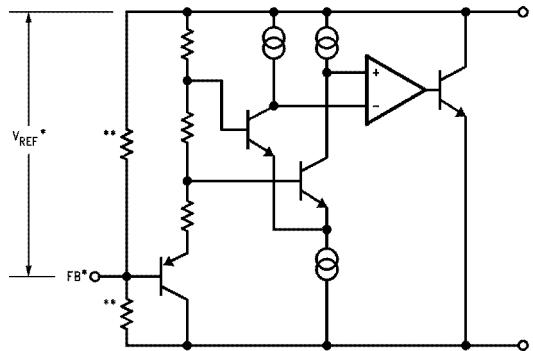

TL/H/11392-21

*LM4041-ADJ only
**LM4041-1.2 only

Applications Information

The LM4041 is a precision micro-power curvature-corrected bandgap shunt voltage reference. For space critical applications, the LM4041 is available in the sub-miniature SOT-23 surface-mount package. The LM4041 has been designed for stable operation without the need of an external capacitor connected between the “+” pin and the “-” pin. If, however, a bypass capacitor is used, the LM4041 remains stable. Design effort is further reduced with the choice of either a fixed 1.2V or an adjustable reverse breakdown voltage. The minimum operating current is 60 μ A for the LM4041-1.2 and the LM4041-ADJ. Both versions have a maximum operating current of 12 mA.

LM4041s using the SOT-23 package have pin 1 connected as the (-) output through the package's die attach interface. Therefore, the LM4041-1.2's pin 1 must be left floating or connected to pin 3 and the LM4041-ADJ's pin 1 is the (-) output.

In a conventional shunt regulator application (*Figure 1*), an external series resistor (R_S) is connected between the supply voltage and the LM4041. R_S determines the current that flows through the load (I_L) and the LM4041 (I_Q). Since load current and supply voltage may vary, R_S should be small enough to supply at least the minimum acceptable I_Q to the LM4041 even when the supply voltage is at its minimum and the load current is at its maximum value. When the supply voltage is at its maximum and I_L is at its minimum, R_S should be large enough so that the current flowing through the LM4041 is less than 12 mA.

R_S is determined by the supply voltage, (V_S), the load and operating current, (I_L and I_Q), and the LM4041's reverse breakdown voltage, V_R .

$$R_S = \frac{V_S - V_R}{I_L + I_Q}$$

The LM4041-ADJ's output voltage can be adjusted to any value in the range of 1.24V through 10V. It is a function of the internal reference voltage (V_{REF}) and the ratio of the external feedback resistors as shown in *Figure 2*. The output is found using the equation

$$V_O = V_{REF}' \left(\frac{R_2}{R_1} + 1 \right) \quad (1)$$

where V_O is the desired output voltage. The actual value of the internal V_{REF} is a function of V_O . The “corrected” V_{REF} is determined by

$$V_{REF}' = V_O (\Delta V_{REF}/\Delta V_O) + V_Y \quad (2)$$

where V_O is the desired output voltage. $\Delta V_{REF}/\Delta V_O$ is found in the Electrical Characteristics and it typically -1.3 mV/V and V_Y is equal to 1.240V. Replace the value of V_{REF}' in equation (1) with the value found using equation (2).

Note that the actual output voltage can deviate from that predicted using the typical $\Delta V_{REF}/\Delta V_O$ in equation (2): for C-grade parts, the worst-case $\Delta V_{REF}/\Delta V_O$ is -2.5 mV/V and $V_Y = 1.246$ V. For D-grade parts, the worst-case $\Delta V_{REF}/\Delta V_O$ is -3.0 mV/V and $V_Y = 1.248$ V.

The following example shows the difference in output voltage resulting from the typical and worst case values of $\Delta V_{REF}/\Delta V_O$. Let $V_O = +9$ V. Using the typical value of $\Delta V_{REF}/\Delta V_O$, V_{REF} is 1.228V. Choosing a value of $R_1 = 10$ k Ω , $R_2 = 63.272$ k Ω . Using the worst case $\Delta V_{REF}/\Delta V_O$ for the C-grade and D-grade parts, the output voltage is actually 8.965V and 8.946V, respectively. This results in possible errors as large as 0.39% for the C-grade parts and 0.59% for the D-grade parts. Once again, resistor values found using the typical value of $\Delta V_{REF}/\Delta V_O$ will work in most cases, requiring no further adjustment.

Typical Applications

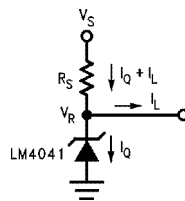

TL/H/11392-22

FIGURE 1. Shunt Regulator

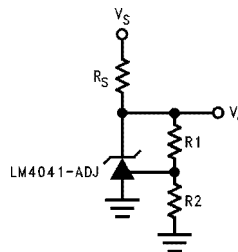

TL/H/11392-34

FIGURE 2. Adjustable Shunt Regulator

Typical Applications (Continued)

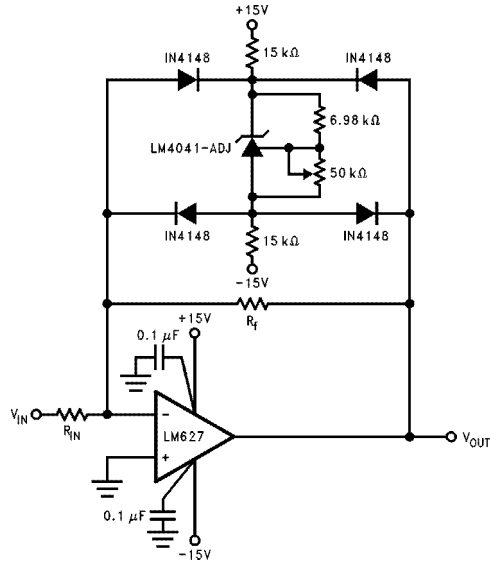

TL/H/11392-24

FIGURE 3. Bounded amplifier reduces saturation-induced delays and can prevent succeeding stage damage. Nominal clamping voltage is $\pm V_O$ (LM4041's reverse breakdown voltage) $+ 2$ diode V_F .

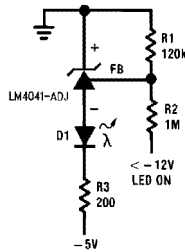

TL/H/11392-20

FIGURE 4. Voltage Level Detector

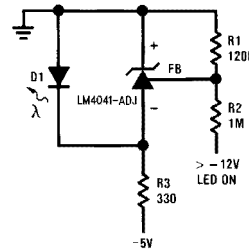

TL/H/11392-23

FIGURE 5. Voltage Level Detector

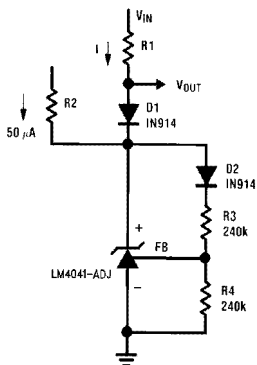

TL/H/11392-25

**FIGURE 6. Fast Positive Clamp
 $2.4V + \Delta V_{D1}$**

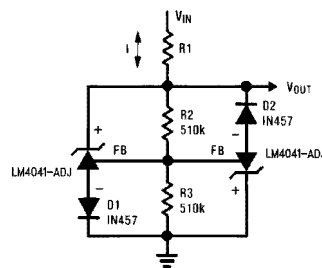

TL/H/11392-26

FIGURE 7. Bidirectional Clamp $\pm 2.4V$

Typical Applications (Continued)

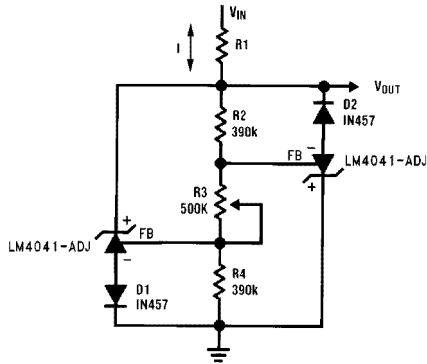

TL/H/11392-35

FIGURE 7. Bidirectional Adjustable Clamp $\pm 18V$ to $\pm 2.4V$

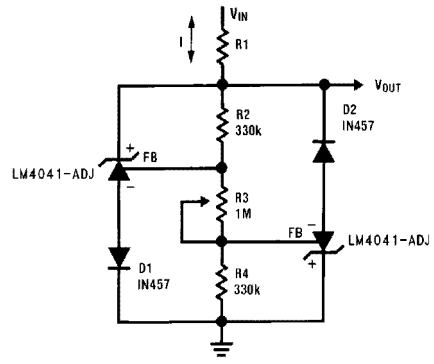

TL/H/11392-36

FIGURE 8. Bidirectional Adjustable Clamp $\pm 2.4V$ to $\pm 6V$

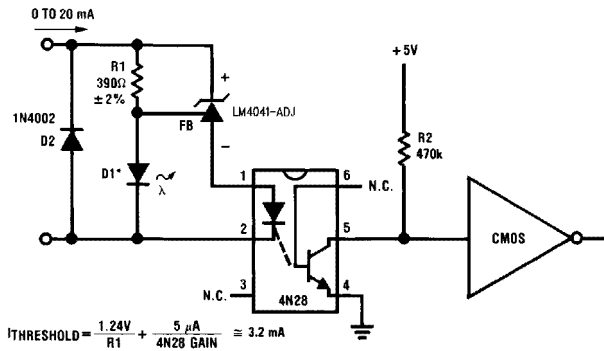

TL/H/11392-37

FIGURE 9. Simple Floating Current Detector

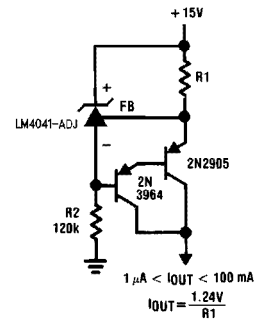

TL/H/11392-38

FIGURE 10. Current Source

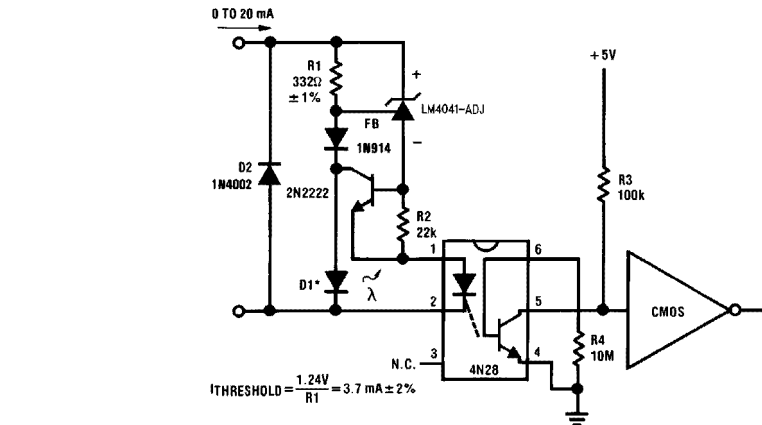

TL/H/11392-39

FIGURE 11. Precision Floating Current Detector

*D1 can be any LED, $V_F = 1.5V$ to $2.2V$ at 3 mA . D1 may act as an indicator. D1 will be on if $I_{\text{THRESHOLD}}$ falls below the threshold current, except with $I = 0$.

Typical Applications (Continued)

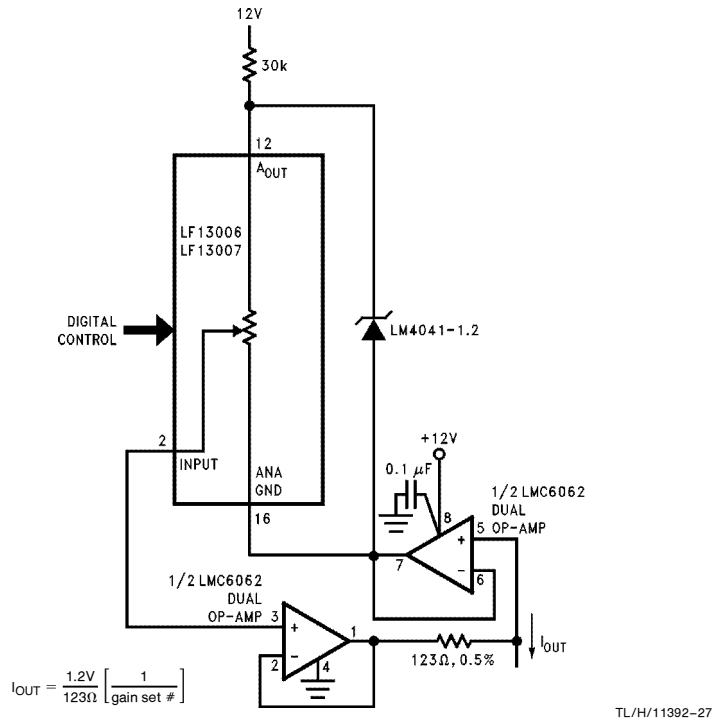

FIGURE 12. Programmable Current Source

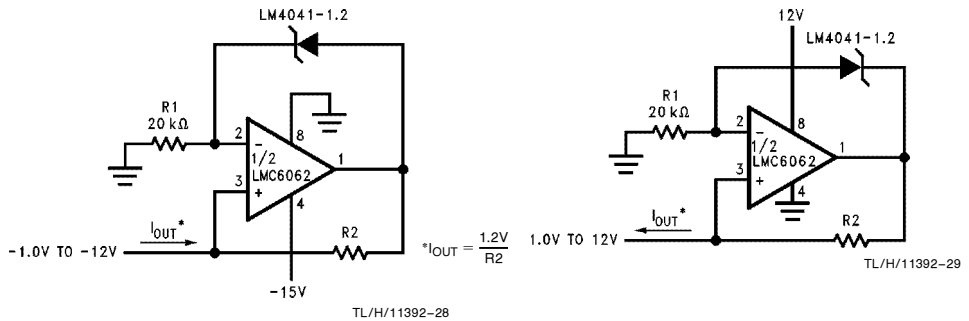
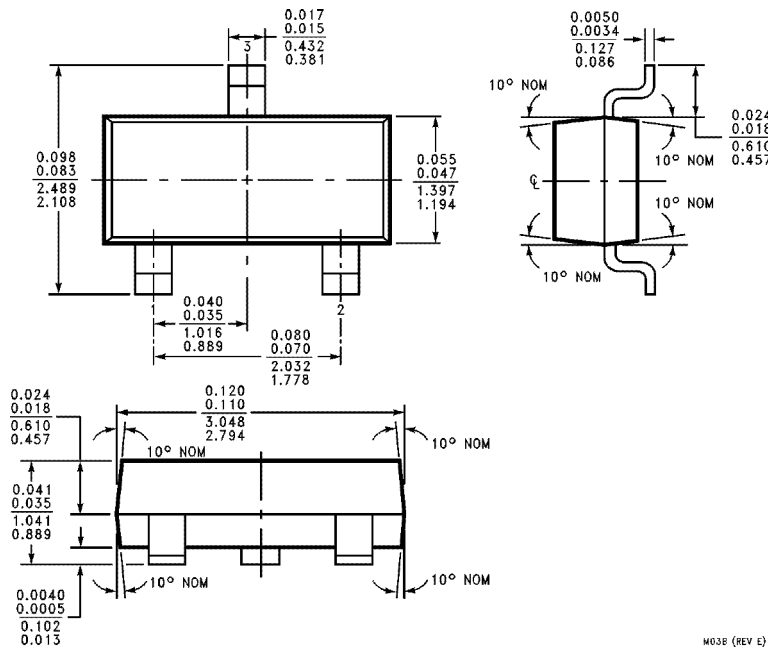

FIGURE 13. Precision 1 μ A to 1 mA Current Sources

Physical Dimensions inches (millimeters)



Plastic Surface Mount Package (M3)
NS Package Number M03B
(JEDEC Registration TO-236AB)

M03B (REV E)

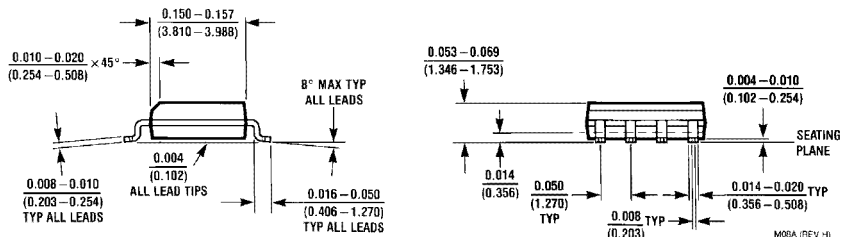
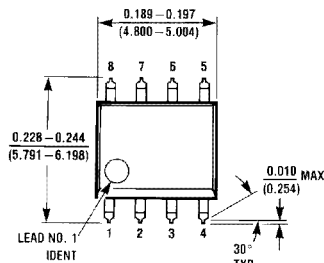

Plastic Surface Mount Package (M)
NS Package Number M08A

M08A (REV H)

Physical Dimensions inches (millimeters) (Continued)

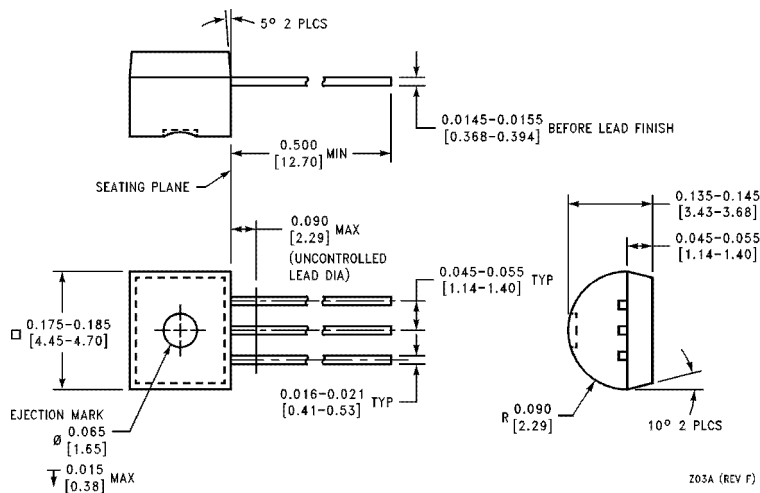

**Plastic Package (Z)
NS Package Number Z03A**

Z03A (REV F)

LIFE SUPPORT POLICY

NATIONAL'S PRODUCTS ARE NOT AUTHORIZED FOR USE AS CRITICAL COMPONENTS IN LIFE SUPPORT DEVICES OR SYSTEMS WITHOUT THE EXPRESS WRITTEN APPROVAL OF THE PRESIDENT OF NATIONAL SEMICONDUCTOR CORPORATION. As used herein:

1. Life support devices or systems are devices or systems which, (a) are intended for surgical implant into the body, or (b) support or sustain life, and whose failure to perform, when properly used in accordance with instructions for use provided in the labeling, can be reasonably expected to result in a significant injury to the user.
2. A critical component is any component of a life support device or system whose failure to perform can be reasonably expected to cause the failure of the life support device or system, or to affect its safety or effectiveness.



National Semiconductor Corporation
1111 West Bardin Road
Arlington, TX 76017
Tel: 1(800) 272-9959
Fax: 1(800) 737-7018

National Semiconductor Europe
Fax: (+49) 0-180-530 85 86
Email: cnjwge@tevm2.nsc.com
Deutsch Tel: (+49) 0-180-530 85 85
English Tel: (+49) 0-180-532 78 32
Français Tel: (+49) 0-180-532 93 58
Italiano Tel: (+49) 0-180-534 16 80

National Semiconductor Hong Kong Ltd.
13th Floor, Straight Block,
Ocean Centre, 5 Canton Rd.
Tsimshatsui, Kowloon
Hong Kong
Tel: (852) 2737-1600
Fax: (852) 2736-9960

National Semiconductor Japan Ltd.
Tel: 81-043-299-2309
Fax: 81-043-299-2408