

LM3622 Lithium-Ion Battery Charger Controller

General Description

The LM3622 is a charge controller for Lithium-Ion batteries. This monolithic integrated circuit accurately controls an external pass transistor for precision Lithium-Ion battery charging. The LM3622 provides a constant voltage or constant current (CVCC) configuration that changes, as necessary, to optimally charge lithium-ion battery cells. Voltage charging versions (4.1V, 4.2V, 8.2V, and 8.4V) are available for one or two cell battery packs and for coke or graphite anode battery chemistry.

The LM3622 accepts input voltages from 4.5V to 24V. Controller accuracy over temperature is $\pm 30\text{mV/cell}$ for A grade and $\pm 50\text{mV/cell}$ for the standard grade. No precision external resistors are required. Furthermore, the LM3622's proprietary output voltage sensing circuit drains less than 200nA from the battery when the input source is disconnected.

The LM3622 circuitry includes functions for regulating the charge voltage with a temperature compensated bandgap reference and regulating the current with an external sense resistor. The internal bandgap insures excellent controller performance over the operating temperature and input supply range.

The LM3622 can sink 15mA minimum at the EXT pin to drive the base of an external PNP pass transistor. It also has

low-voltage battery threshold circuitry that removes this drive when the cell voltage drops below a preset limit. The LV_{SEL} pin programs this threshold voltage to either 2.7V/cell or 2.15V/cell. The low-voltage detection, which is a user enabled feature, provides an output signal that can be used to enable a "wake up charge" source automatically to precondition a deeply discharged pack.

The LM3622 is available in a standard 8-lead SOIC surface mount package.

Features

- Versions for charging of 1 cell (4.1V or 4.2V) or 2 cells (8.2V or 8.4V)
- Versions for coke or graphite anode
- Precision ($\pm 30\text{mV/cell}$) end-of-charge control
- Wide input range: 4.5V-24V
- Low battery drain leakage: 200nA
- 15 mA available to drive low cost PNP

Applications

- Cellular phone cradle charger
- PDA/Notebook cradle charger
- Camcorder cradle charger

Typical Application

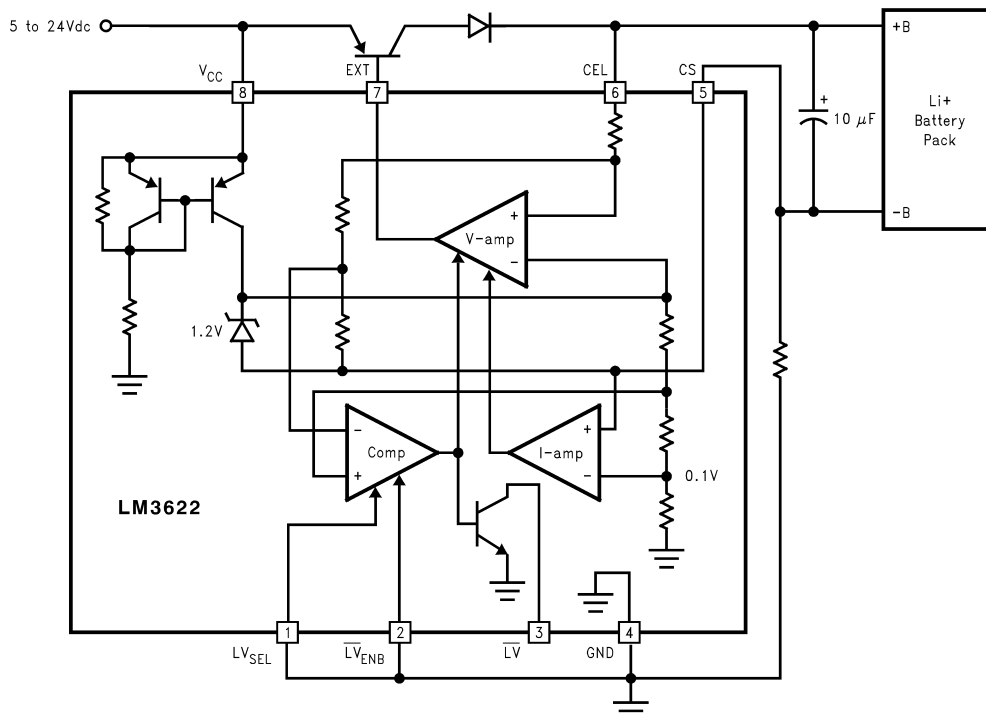

DS100974-1

Connection Diagram

8-Lead Surface Mount Package

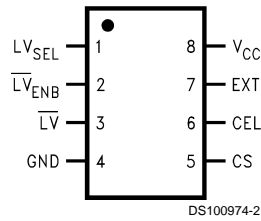

Refer to the Ordering Information Table in this Datasheet for Specific Part Number
See NS Package M08A

Pin Description

Pin No.	Name	I/O	Description
1	LV _{SEL}	Input	Low-voltage detection threshold Select. The threshold is 2.15V/cell when this pin is pulled low to GND and 2.70V/cell when it is pulled up to V _{CC} . The battery voltage is sensed between CEL and CS pins.
2	LV _{ENB}	Input	Low-voltage detection Enable. The low-voltage detection is enabled when this pin is pulled Low to GND. Pulling this pin HIGH to V _{CC} disables the low-voltage detection.
3	LV	Output	Output of the low-voltage detection. This pin is a NPN open-collector output that goes to low impedance state when LV _{ENB} is pulled LOW and the battery voltage is below the threshold set by LV _{SEL} . LV stays in HIGH impedance state at any battery voltage when LV _{ENB} is pulled HIGH to V _{CC} . LV can be used for turning on a low current source to recondition a deeply depleted battery.
4	GND	Ground	IC common.
5	CS	Input	Input for battery charge current and battery negative-terminal voltage sensing. Battery charging current is sensed through an external resistor, R _{CS} , connected between the battery's negative terminal and GND. The maximum charge current is regulated to a value of 100mV/R _{CS} .
6	CEL	Input	Battery positive-terminal voltage sensing.
7	EXT	Output	Output of the controller for driving a PNP transistor or P-MOSFET. The controller modulates the current sinking into this pin to control the regulation of either the charge current or the battery voltage.
8	V _{CC}	Power Supply	IC power supply

Ordering Information

Voltage	Grade	Accuracy	Order Information	Supplied As
4.1V	A	$\pm 30\text{mV}$	LM3622AM-4.1	95 unit increments in rail
4.1V	A	$\pm 30\text{mV}$	LM3622AMX-4.1	2500 unit increments in tape and reel
4.1V	Standard	$\pm 50\text{mV}$	LM3622M-4.1	95 unit increments in rail
4.1V	Standard	$\pm 50\text{mV}$	LM3622MX-4.1	2500 unit increments in tape and reel
4.2V	A	$\pm 30\text{mV}$	LM3622AM-4.2	95 unit increments in rail
4.2V	A	$\pm 30\text{mV}$	LM3622AMX-4.2	2500 unit increments in tape and reel
4.2V	Standard	$\pm 50\text{mV}$	LM3622M-4.2	95 unit increments in rail
4.2V	Standard	$\pm 50\text{mV}$	LM3622MX-4.2	2500 unit increments in tape and reel
8.2V	A	$\pm 60\text{mV}$	LM3622AM-8.2	95 unit increments in rail
8.2V	A	$\pm 60\text{mV}$	LM3622AMX-8.2	2500 unit increments in tape and reel
8.2V	Standard	$\pm 100\text{mV}$	LM3622M-8.2	95 unit increments in rail
8.2V	Standard	$\pm 100\text{mV}$	LM3622MX-8.2	2500 unit increments in tape and reel
8.4V	A	$\pm 60\text{mV}$	LM3622AM-8.4	95 unit increments in rail
8.4V	A	$\pm 60\text{mV}$	LM3622AMX-8.4	2500 unit increments in tape and reel
8.4V	Standard	$\pm 100\text{mV}$	LM3622M-8.4	95 unit increments in rail
8.4V	Standard	$\pm 100\text{mV}$	LM3622MX-8.4	2500 unit increments in tape and reel

Absolute Maximum Ratings (Note 1)

If Military/Aerospace specified devices are required, please contact the National Semiconductor Sales Office/Distributors for availability and specifications.

Supply Voltage (V_{CC})	-0.3 to 24V
\overline{LV}	-0.3 to 24V
EXT (Note 2)	-0.3 to 24V
LV_{SEL}	-0.3 to 24V
\overline{LV}_{ENB}	-0.3 to 24V
ESD Susceptibility (Note 3)	2500V
Storage Temperature	-40°C to +125°C
Lead Temp. Soldering	
Vapor Phase (60 sec.)	215°C
Infrared (15 sec.)	220°C

Power Dissipation ($T_A = 25^\circ\text{C}$)
(Note 4)

Max. Package Dissipation 350mW

Operating Ratings (Note 1)

Supply Voltage (V_{CC})	4.5V to 24V
Ambient Temperature Range	-20°C to 70°C
Junction Temperature Range	-20°C to 85°C
Thermal Resistance, θ_{JA}	
SOIC-8	170°C/W

Electrical Characteristics**LM3622-XX**

Unless otherwise specified $V_{CC} = 5\text{V/Cell}$ $T_A = T_J = 25^\circ\text{C}$. Limits with standard typeface apply for $T_J = 25^\circ\text{C}$, and limits in **bold-face type** apply over the indicated temperature range.

Symbol	Parameter	Conditions	Min	Typ	Max	Units
V_{CC}	Operating power supply range		4.5		24.0	V
I_{CC}	Quiescent Current			210		μA
V_{CEL}	Regulation Voltage	$T_J = 0^\circ\text{C}$ to $+70^\circ\text{C}$ $V_{CC} = 4.5\text{V/cell}$ (Note 5)				V
	LM3622A-4.1		4.070	4.100	4.130	V
	LM3622A-8.2		8.140	8.200	8.260	V
	LM3622A-4.2		4.170	4.200	4.230	V
	LM3622A-8.4		8.340	8.400	8.460	V
	LM3622-4.1		4.050	4.100	4.150	V
	LM3622-8.2		8.100	8.200	8.300	V
V_{CS}	LM3622-4.2		4.150	4.200	4.250	V
	LM3622-8.4		8.300	8.400	8.500	V
	Long Term Stability	(Note 6)		0.02		%
V_{CS}	Current limit threshold at CS pin	$V_{CEL} = 4\text{V}$ for LM3622-4.X $V_{CEL} = 8\text{V}$ for LM3622-8.X	90	100	110	mV
I_{CEL}	Current in CEL pin	V_{CC} Supply connected		25		μA
		V_{CC} Supply Open		200		nA
LV_{th}	Low voltage detect threshold (between pins CS and GND)	$\overline{LV}_{ENB} = 0\text{V}$ and $LV_{SEL} = 0\text{V}$	2.00	2.15	2.30	V/Cell
		$\overline{LV}_{ENB} = 0\text{V}$ and $LV_{SEL} = V_{CC}$	2.55	2.70	2.85	V/Cell
I_{EXT}	EXT pin output sink current	$V_{EXT} = 4\text{V}$ for LM3622-4.X $V_{EXT} = 8\text{V}$ for LM3622-8.X	15	25		mA
I_{IN1}	LV_{SEL} input current	$LV_{SEL} = 5\text{V}$, LM3622-4.X		20		μA
		$LV_{SEL} = 10\text{V}$, LM3622-8.X		50		μA
I_{IN2}	\overline{LV}_{ENB} input current	$\overline{LV}_{ENB} = 5\text{V}$, LM3622-4.X		20		μA
		$\overline{LV}_{ENB} = 10\text{V}$, LM3622-8.X		50		μA
$I_{\overline{LV}}$	\overline{LV} pin leakage current	$\overline{LV} = 5\text{V/Cell}$			250	nA
$V_{\overline{LV}}$	\overline{LV} pin saturation voltage	$I_{SINK} = 1\text{mA}$ $T_J = -20^\circ\text{C}$ to 85°C		0.25	0.40	V

Note 1: Absolute Maximum Ratings indicate limits beyond which damage to the device may occur. Operating Ratings indicate conditions for which the device is intended to be functional, but do not guarantee specific performance limits. For guaranteed specifications and test conditions, see the Electrical Characteristics.

Note 2: V_{EXT} is not allowed to exceed ($V_{CC} + 0.3\text{V}$) or damage to the device may occur.

Note 3: Rating is for the human body model, a 100 pF capacitor discharged through a 1.5k Ω resistor into each pin.

Note 4: The maximum power dissipation must be de-rated at elevated temperatures and is limited by T_{JMAX} (maximum junction temperature), θ_{JA} (junction-to-ambient thermal resistance) and T_A (ambient temperature). The maximum power dissipation at any temperature is: $PD_{MAX} = (T_{JMAX} - T_A) / \theta_{JA}$ up to the value listed in the Absolute Maximum Ratings.

Note 5: Limits reflect initial accuracy.

Note 6: $T_J = 85^\circ\text{C}$, 1000 hours. Activation energy of 0.78eV used.

Typical Performance Characteristics Unless otherwise specified, $T_A = 25^\circ\text{C}$.

Output Voltage Regulation Vs V_{CC}

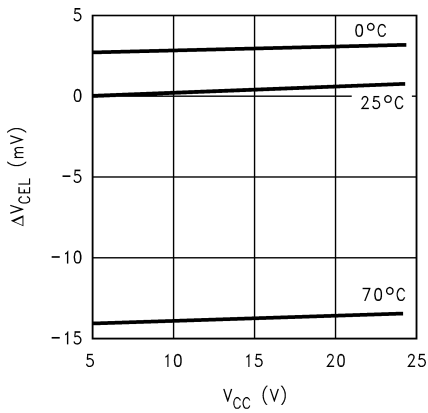

Current Sense Voltage Regulation Vs V_{CC}

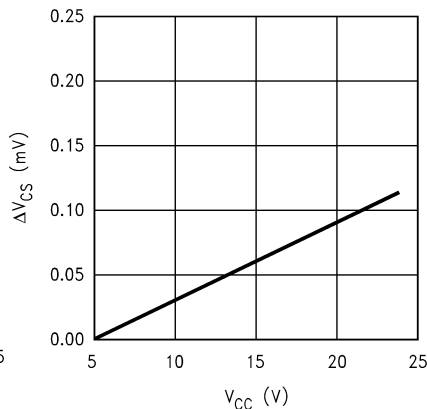

Current Sense Voltage Regulation Vs Temperature

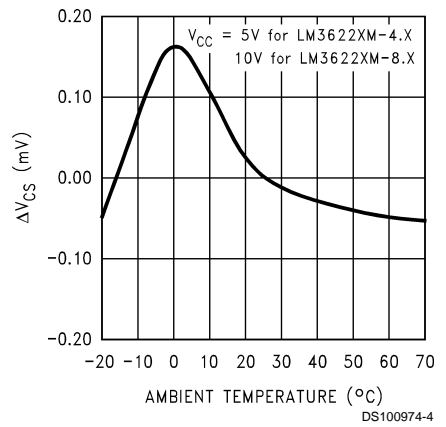

Output Drive Current Vs V_{CC}

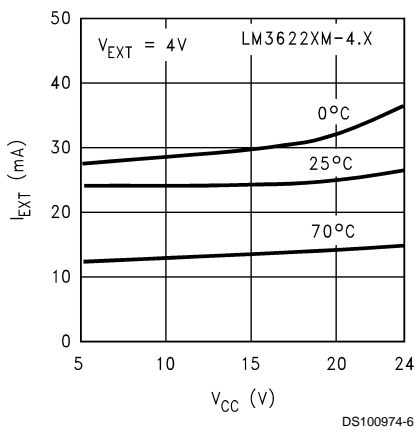

Output Drive Current Vs V_{CC}

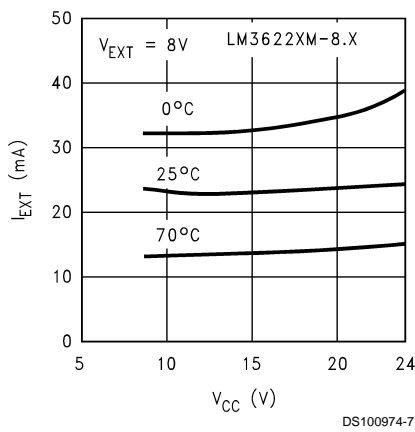

Quiescent Current Vs V_{CC}

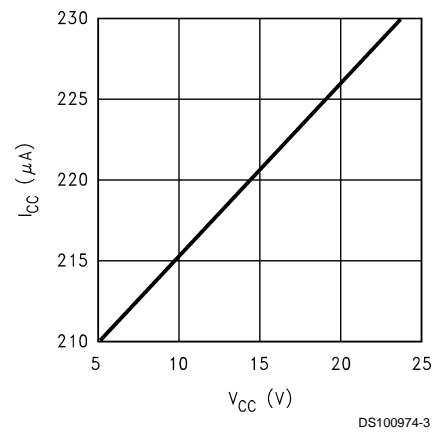

Functional Description

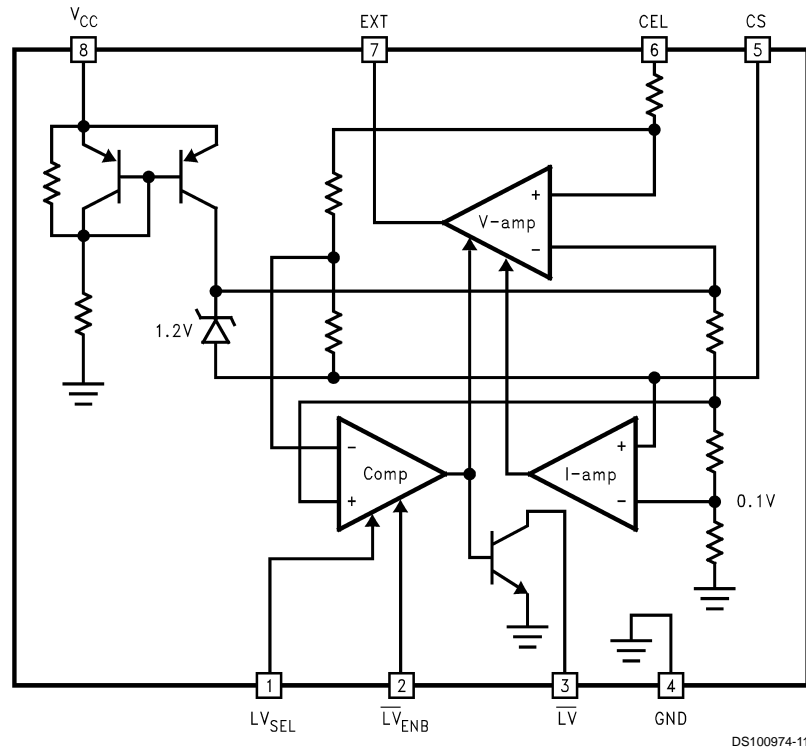

FIGURE 1. LM3622 Simplified Block Diagram

The simplified LM3622 block diagram in *Figure 1* gives a general idea of the circuit operation. The controller integrates the reference, feedback and drive functions on-chip to control a linear, lithium-ion battery charger in constant voltage and constant current (CVCC) charge operation. The regulated output voltage is sensed between CEL and CS, and the battery charge current is sensed across a current-sense resistor between CS and GND. The EXT pin is designed for driving a series pass element, which can be a PNP transistor or a P-MOSFET.

Tying the \overline{LV}_{ENB} pin to ground enables the controller's low-voltage detection circuit. When the low-voltage detection circuit is enabled and a battery voltage below a preset threshold is detected, the LM3622 will drive the \overline{LV} pin low and shut off the current flowing into the EXT pin to suspend the CVCC charge process. The low-voltage threshold is user selectable to be either 2.15V/cell or 2.7V/cell by pulling the LV_{SEL} pin to GND or V_{CC} respectively. The \overline{LV} pin is an NPN open collector output that can be used to turn on a low current source to wake up charge a deeply depleted battery. When the low-voltage detection is disabled (\overline{LV}_{ENB} pulled up to V_{CC}), the LM3622 always starts the charge cycle in constant current mode at any battery voltage below the controller's regulation level, and maintains the \overline{LV} pin at a high-impedance state.

Application Information

CEL Pin Current Drain

The LM3622 has an internal power down switch in series with the on-chip resistor divider that is used for sensing the battery voltage. In the event that the V_{CC} supply is removed,

the power down switch will disconnect the resistor divider from the CS pin, preventing the battery from discharging through the CEL pin.

EXT Pin

The EXT pin is internally pulled up to V_{CC} via a 20 μ A current source making it possible to eliminate the external base-emitter resistor when driving a PNP transistor, or the gate-source resistor when driving a P-MOSFET. However, the voltage applied to EXT is not allowed to be higher than ($V_{CC} + 0.3V$), otherwise the reverse current from EXT pin to V_{CC} pin may cause damage to the device.

\overline{LV} Pin Current Rating

The \overline{LV} pin is a low power, NPN open collector output that is rated to sink 10mA maximum. Therefore, the value of the pull up resistor should be chosen high enough to limit the current to be less than 10mA.

CS Pin

In normal operation, the current limit threshold voltage for the CS pin is 100mV typical. In case of a fault condition, the voltage to this pin should be limited to below 5V.

Typical Application

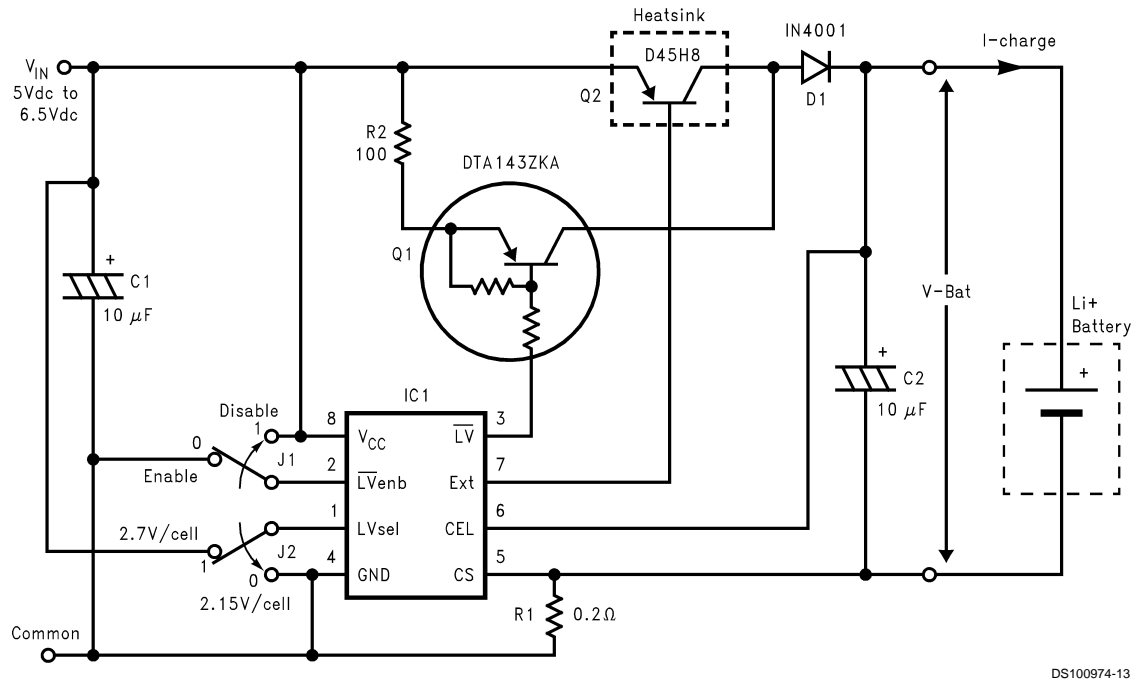

FIGURE 2. Low Dropout, Constant Current/Constant Voltage Li-ion Battery Charger

The low dropout linear charger shown in *Figure 2* provides constant current and constant voltage charging of 1-cell lithium-ion battery packs. J1 and J2 are used for selecting the operation of the low-voltage detection. The LM3622 initializes the charge cycle based on the battery voltage and the enable status of the low-voltage detection.

When the low-voltage detection is disabled, the LM3622 starts the charge cycle constant current mode if the battery voltage is below the controller's regulation level. In constant current mode, the LM3622 modulates the base drive of Q2 to regulate a constant 100mV across the current sense resistor R1, thus generating charge current of

$$I\text{-charge} = 0.1V/R1$$

which is equal to 0.5A in this case.

Once the battery voltage reaches the target regulation level set by the LM3622, Q2 is controlled to regulate the voltage across the battery, and the constant voltage mode of the charging cycle starts. Once the charger is in the constant voltage mode, the charger maintains a regulated voltage across the battery and the charging current is dependent on the state of the charge of the battery. As the cell approaches a fully charged condition, the charge current falls to a very low value.

When the low-voltage detection is enabled and the initial battery voltage is below the low-voltage threshold, the LM3622 turns Q2 off and forces the \overline{LV} pin low to drive Q1 on to start a wake up charge phase. Q1 in conjunction with R2 provides a low current source to recondition the battery. During the wake up charge mode, Q1 is driven into saturation and the wake up charge current is programmed by R2,

$$I\text{-charge (wake)} = (V_{IN} - V_{CE1} - V_{D1} - LV_{th})/R2$$

where V_{IN} is the input supply voltage, V_{CE1} is the collector-emitter on state voltage of Q1, V_{D1} is the diode forward voltage of D1, and LV_{th} is the low-voltage threshold level set by switch J2.

Once the battery voltage reaches the low-voltage threshold, the \overline{LV} pin transitions to a high-impedance state to end the wake up charge phase, and the EXT pin resumes the base drive of Q2 to start the constant current mode. The charging cycle is completed in constant voltage mode when the battery is fully charged. *Figure 3* shows the timing diagram of the charge cycle with the low-voltage detection enabled.

D1 is a general-purpose silicon diode used for isolating the battery from the charger circuitry that could discharge the battery when the input source is removed. Changing D1 to a Schottky diode will reduce the overall dropout voltage of the circuit, but the penalty is higher leakage current associated with Schottky diodes.

DS100974-13

Timing Diagram

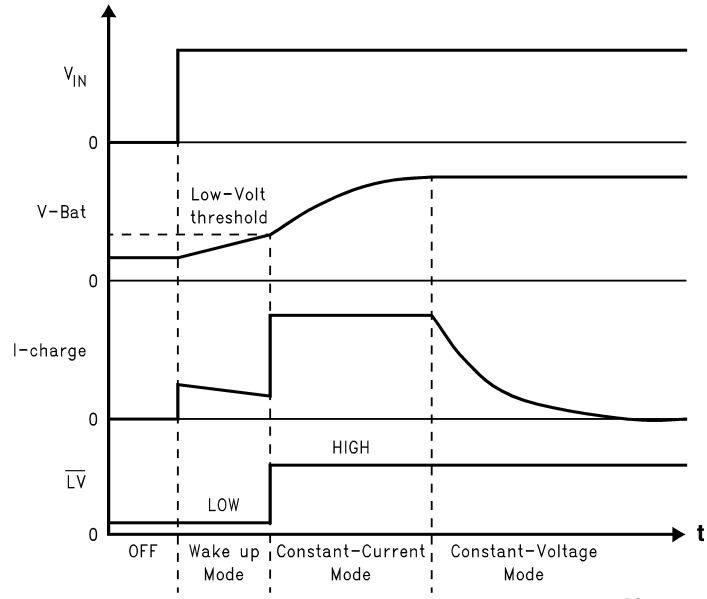

DS100974-12

FIGURE 3. Typical Charge Cycle with Low-Voltage Detection Enabled.

Physical Dimensions inches (millimeters) unless otherwise noted

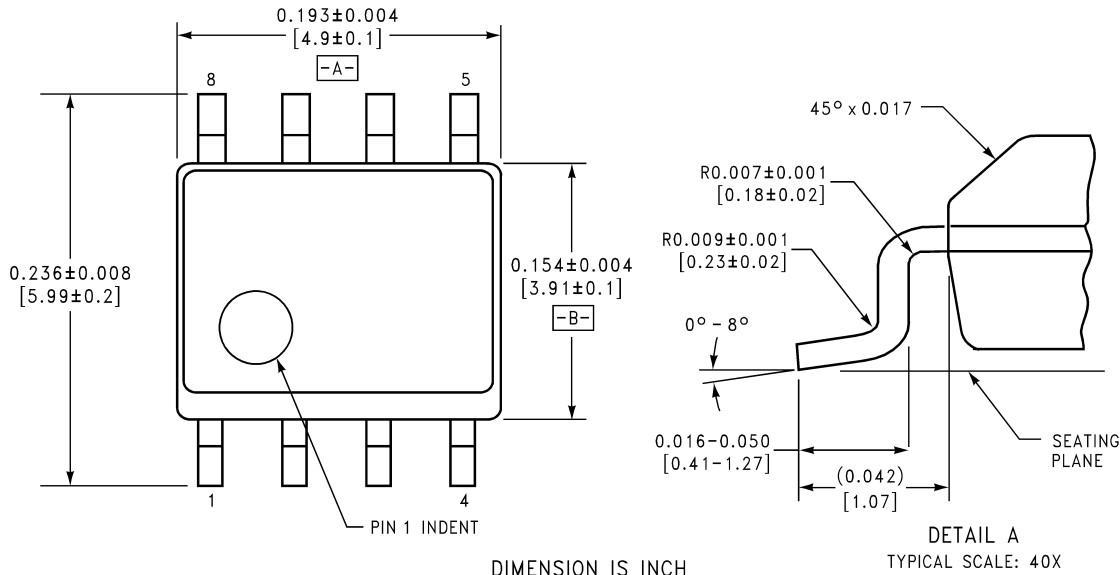

DIMENSION IS INCH
VALUES IN [] ARE MILLIMETERS

DETAIL A
TYPICAL SCALE: 40X

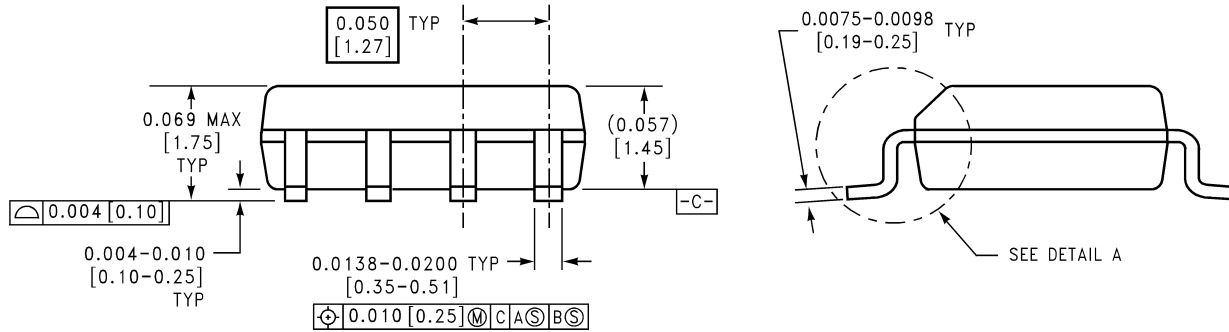

SOIC-8 Package
8-Lead Small-Outline Package (M8)
For Ordering, Refer to Ordering Information Table
NS Package Number M08A

LIFE SUPPORT POLICY

NATIONAL'S PRODUCTS ARE NOT AUTHORIZED FOR USE AS CRITICAL COMPONENTS IN LIFE SUPPORT DEVICES OR SYSTEMS WITHOUT THE EXPRESS WRITTEN APPROVAL OF THE PRESIDENT AND GENERAL COUNSEL OF NATIONAL SEMICONDUCTOR CORPORATION. As used herein:

1. Life support devices or systems are devices or systems which, (a) are intended for surgical implant into the body, or (b) support or sustain life, and whose failure to perform when properly used in accordance with instructions for use provided in the labeling, can be reasonably expected to result in a significant injury to the user.
2. A critical component is any component of a life support device or system whose failure to perform can be reasonably expected to cause the failure of the life support device or system, or to affect its safety or effectiveness.

National Semiconductor Corporation
Americas
Tel: 1-800-272-9959
Fax: 1-800-737-7018
Email: support@nsc.com
www.national.com

National Semiconductor Europe
Fax: +49 (0) 180-530 85 86
Email: europe.support@nsc.com
Deutsch Tel: +49 (0) 69 9508 6208
English Tel: +44 (0) 870 24 0 2171
Français Tel: +33 (0) 1 41 91 8790

National Semiconductor Asia Pacific Customer Response Group
Tel: 65-2544466
Fax: 65-2504466
Email: ap.support@nsc.com

National Semiconductor Japan Ltd.
Tel: 81-3-5639-7560
Fax: 81-3-5639-7507