

1.2V TO 37V VOLTAGE REGULATOR

- OUTPUT VOLTAGE RANGE : 1.2 TO 37V
- OUTPUT CURRENT IN EXCESS OF 1.5A
- 0.1% LINE AND LOAD REGULATION
- FLOATING OPERATION FOR HIGH VOLTAGES
- COMPLETE SERIES OF PROTECTIONS : CURRENT LIMITING, THERMAL SHUTDOWN AND SOA CONTROL

DESCRIPTION

The LM117/LM217/LM317 are monolithic integrated circuit in TO-220, ISOWATT220, TO-3 and D²PAK packages intended for use as positive adjustable voltage regulators.

They are designed to supply more than 1.5A of load current with an output voltage adjustable over a 1.2 to 37V range.

The nominal output voltage is selected by means of only a resistive divider, making the device exceptionally easy to use and eliminating the stocking of many fixed regulators.

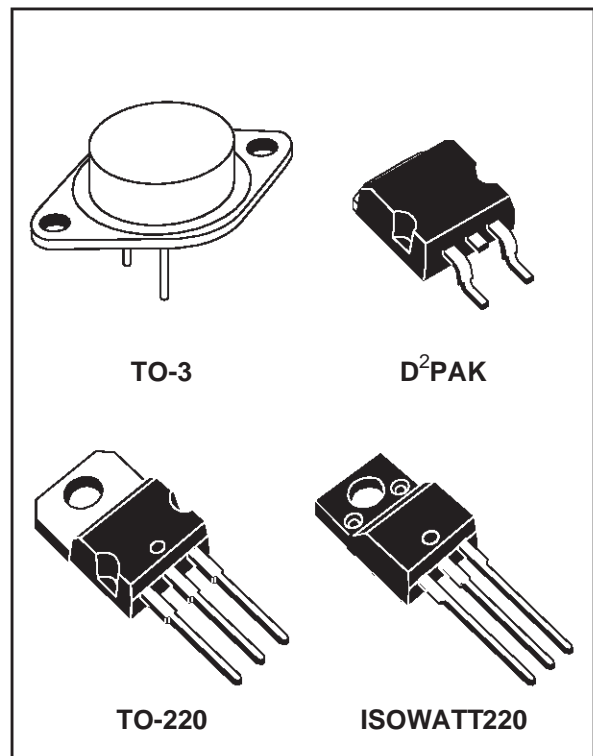

ABSOLUTE MAXIMUM RATING

Symbol	Parameter	Value	Unit
V_{i-o}	Input-output Differential Voltage	40	V
I_o	Output Current	Internally Limited	
T_{op}	Operating Junction Temperature for: LM117 LM217 LM317	-55 to 150 -25 to 150 0 to 125	°C °C °C
P_{tot}	Power Dissipation	Internally Limited	
T_{stg}	Storage Temperature	- 65 to 150	°C

THERMAL DATA

Symbol	Parameter	TO-3	TO-220	ISOWATT220	D ² PAK	Unit
$R_{thj-case}$	Thermal Resistance Junction-case	4	3	4	3	°C/W
$R_{thj-amb}$	Thermal Resistance Junction-ambient	35	50	60	62.5	°C/W

CONNECTION DIAGRAM AND ORDERING NUMBERS (top view)

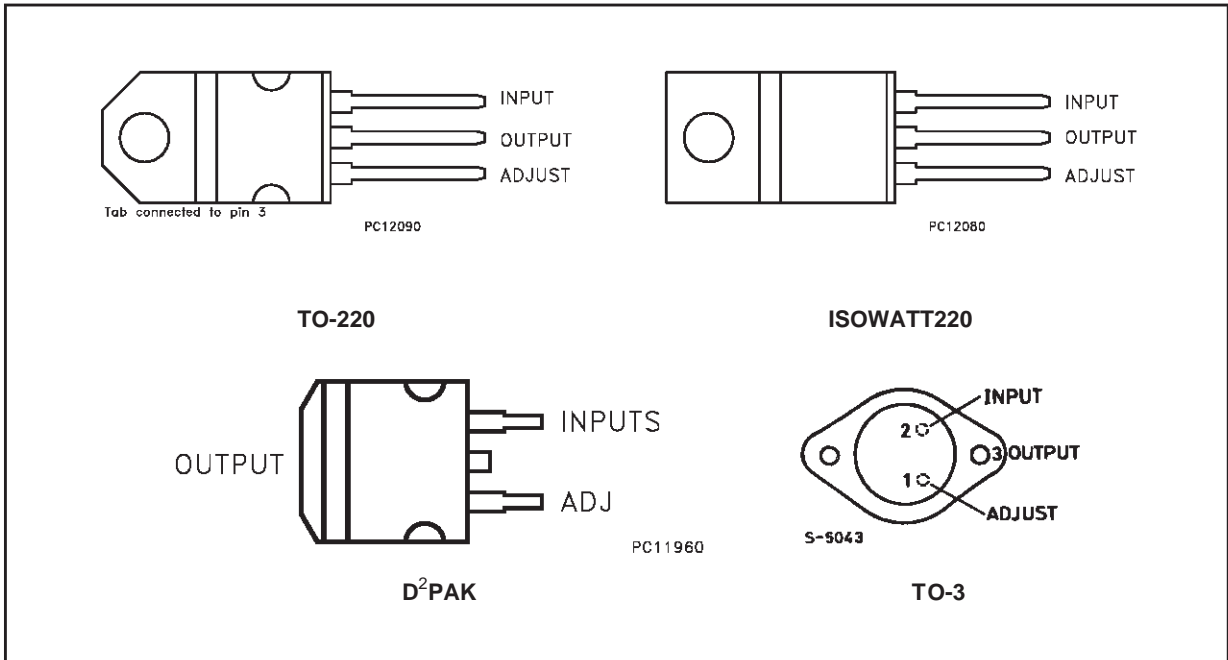

Type	TO-3	TO-220	ISOWATT220	D ² PAK
LM117	LM117K			
LM217	LM217K	LM217T		LM217D2T
LM317	LM317K	LM317T	LM317P	LM317D2T

SCHEMATIC DIAGRAM

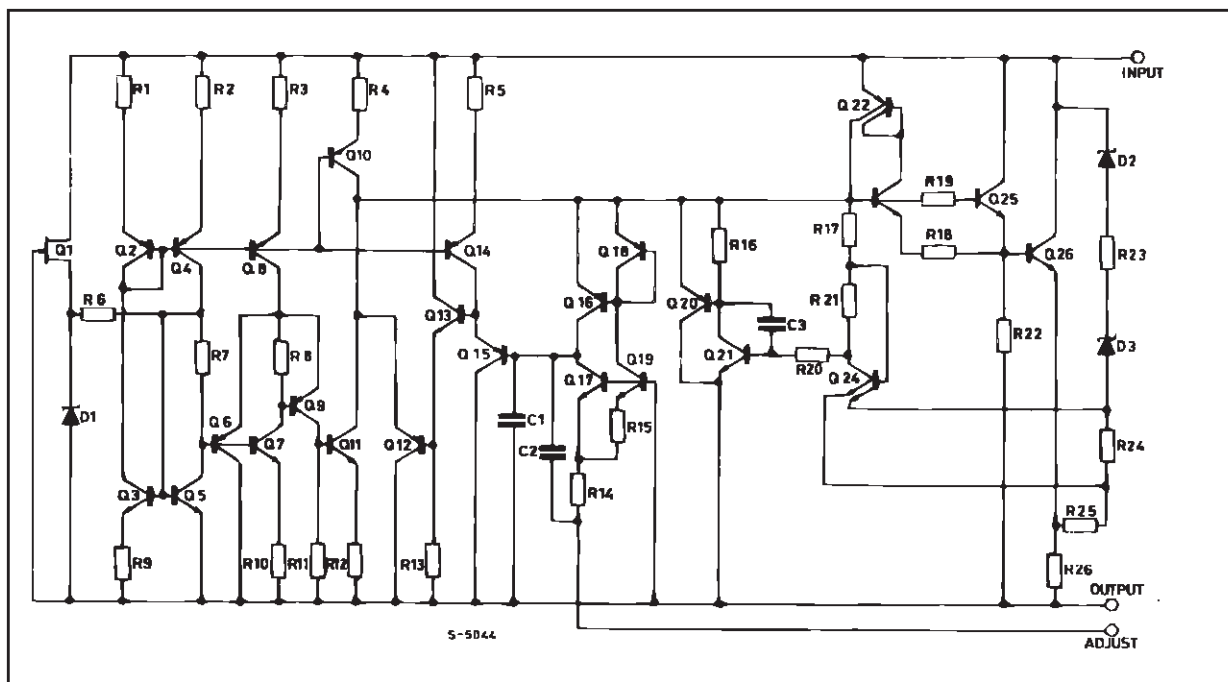

BASIC ADJUSTABLE REGULATOR

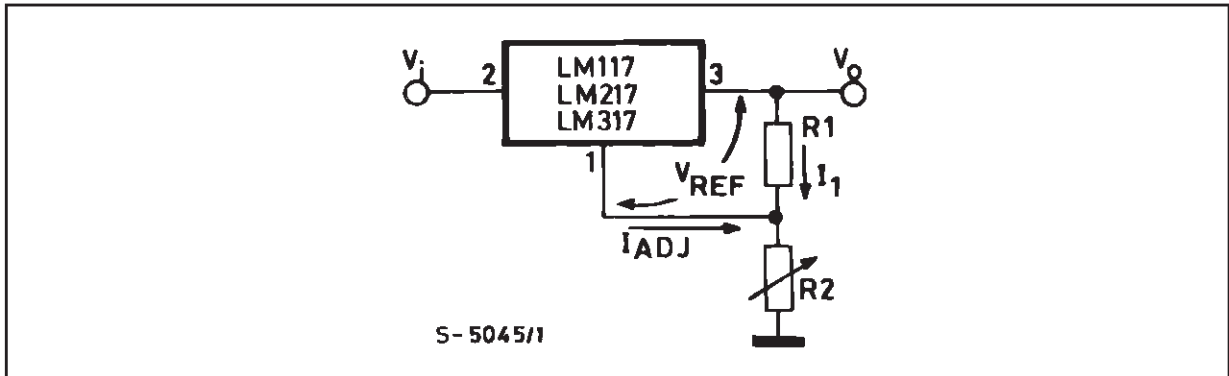

ELECTRICAL CHARACTERISTICS ($V_i - V_o = 5\text{ V}$, $I_o = 500\text{ mA}$, $I_{MAX} = 1.5\text{ A}$ and $P_{MAX} = 20\text{ W}$, unless otherwise specified)

Symbol	Parameter	Test Conditions	LM117/LM217			LM317			Unit	
			Min.	Typ.	Max.	Min.	Typ.	Max.		
ΔV_o	Line Regulation	$V_i - V_o = 3\text{ to }40\text{ V}$ $T_j = 25\text{ }^\circ\text{C}$		0.01	0.02		0.01	0.04	%/V	
				0.02	0.05		0.02	0.07	%/V	
ΔV_o	Load Regulation	$V_o \leq 5\text{ V}$ $I_o = 10\text{ mA to }I_{MAX}$ $T_j = 25\text{ }^\circ\text{C}$		5	15		5	25	mV	
				20	50		20	70	mV	
		$V_o \geq 5\text{ V}$ $I_o = 10\text{ mA to }I_{MAX}$ $T_j = 25\text{ }^\circ\text{C}$		0.1	0.3		0.1	0.5	%	
				0.3	1		0.3	1.5	%	
I_{ADJ}	Adjustment Pin Current		50	100		50	100	μA		
ΔI_{ADJ}	Adjustment Pin Current	$V_i - V_o = 2.5\text{ to }40\text{ V}$ $I_o = 10\text{ mA to }I_{MAX}$		0.2	5		0.2	5	μA	
V_{REF}	Reference Voltage (between pin 3 and pin 1)	$V_i - V_o = 2.5\text{ to }40\text{ V}$ $I_o = 10\text{ mA to }I_{MAX}$ $P_D \leq P_{MAX}$	1.2	1.25	1.3	1.2	1.25	1.3	V	
$\frac{\Delta V_o}{V_o}$	Output Voltage Temperature Stability			1			1		%	
$I_{o(min)}$	Minimum Load Current	$V_i - V_o = 40\text{ V}$		3.5	5		3.5	10	mA	
$I_{o(max)}$	Maximum Load Current	$V_i - V_o \leq 15\text{ V}$ $P_D < P_{MAX}$	1.5	2.2		1.5	2.2		A	
		$V_i - V_o = 40\text{ V}$ $P_D < P_{MAX}$ $T_j = 25\text{ }^\circ\text{C}$		0.4			0.4		A	
e_N	Output Noise Voltage (percentage of V_o)	$B = 10\text{ Hz to }10\text{ KHz}$ $T_j = 25\text{ }^\circ\text{C}$		0.003			0.003		%	
SVR	Supply Voltage Rejection (*)	$T_j = 25\text{ }^\circ\text{C}$ $f = 120\text{ Hz}$	$C_{ADJ} = 0$		65			65		dB
			$C_{ADJ} = 10\mu\text{F}$	66	80		66	80		dB

(*) C_{ADJ} is connected between pin 1 and ground.

Note:

(1) Unless otherwise specified the above specs, apply over the following conditions : LM 117 $T_j = -55\text{ to }150\text{ }^\circ\text{C}$;
LM 217 $T_j = -25\text{ to }150\text{ }^\circ\text{C}$; LM 317 $T_j = 0\text{ to }125\text{ }^\circ\text{C}$.

Figure 1 : Output Current vs. Input-output Differential Voltage.

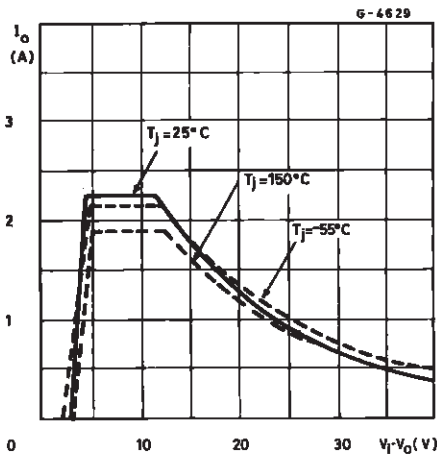

Figure 3 : Reference Voltage vs. Junction

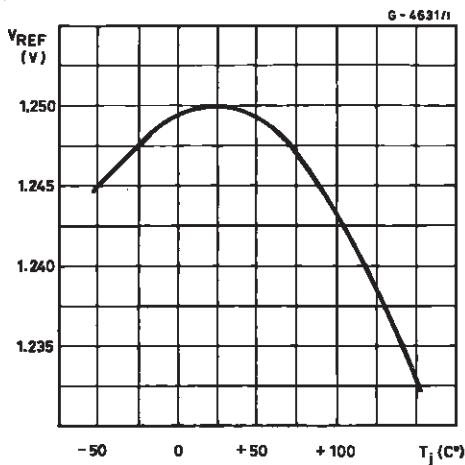

Figure 2 : Dropout Voltage vs. Junction Temperature.

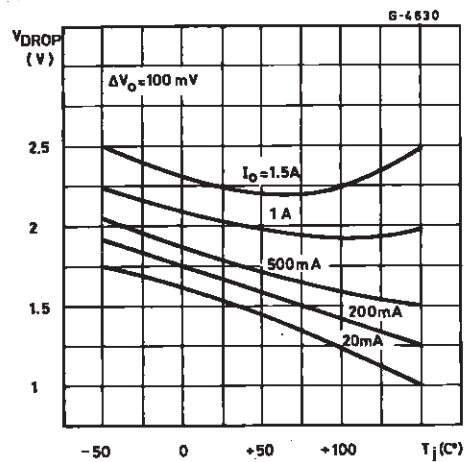
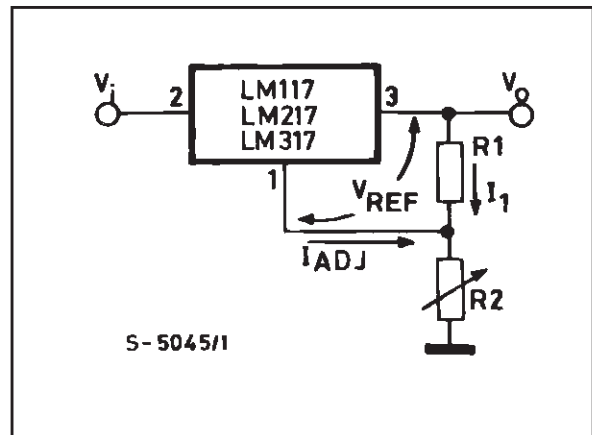

Figure 4 : Basic Adjustable Regulator.



APPLICATION INFORMATION

The LM117/217/317 provides an internal reference voltage of 1.25V between the output and adjustments terminals. This is used to set a constant current flow across an external resistor divider (see fig. 4), giving an output voltage V_o of:

$$V_o = V_{REF} \left(1 + \frac{R_2}{R_1} \right) + I_{ADJ} R_2$$

The device was designed to minimize the term I_{ADJ} (100 μA max) and to maintain it very constant with line and load changes. Usually, the error term $I_{ADJ} \cdot R_2$ can be neglected. To obtain the previous requirement, all the regulator quiescent current is returned to the output terminal, imposing a minimum load current condition. If the load is insufficient, the output voltage will rise.

Since the LM117/217/317 is a floating regulator and "sees" only the input-to-output differential

voltage, supplies of very high voltage with respect to ground, can be regulated as long as the maximum input-to-output differential is not exceeded. Furthermore, programmable regulators are easily obtainable and, by connecting a fixed resistor between the adjustment and output, the device can be used as a precision current regulator.

In order to optimize the load regulation, the current set resistor R_1 (see fig. 4) should be tied as close as possible to the regulator, while the ground terminal of R_2 should be near the ground of the load to provide remote ground sensing.

Performance may be improved with added capacitance as follows:

An input bypass capacitor of 0.1 μF

An adjustment terminal to ground 10 μF capacitor

to improve the ripple rejection of about 15 dB (C_{ADJ}).

An $1\mu\text{F}$ tantalium (or $25\mu\text{F}$ Aluminium electrolytic) capacitor on the output to improve transient response.

In addition to external capacitors, it is good

practice to add protection diodes, as shown in fig.5.

D1 protect the device against input short circuit, while D2 protect against output short circuit for capacitance discharging.

Figure 5 : Voltage Regulator with Protection Diodes.

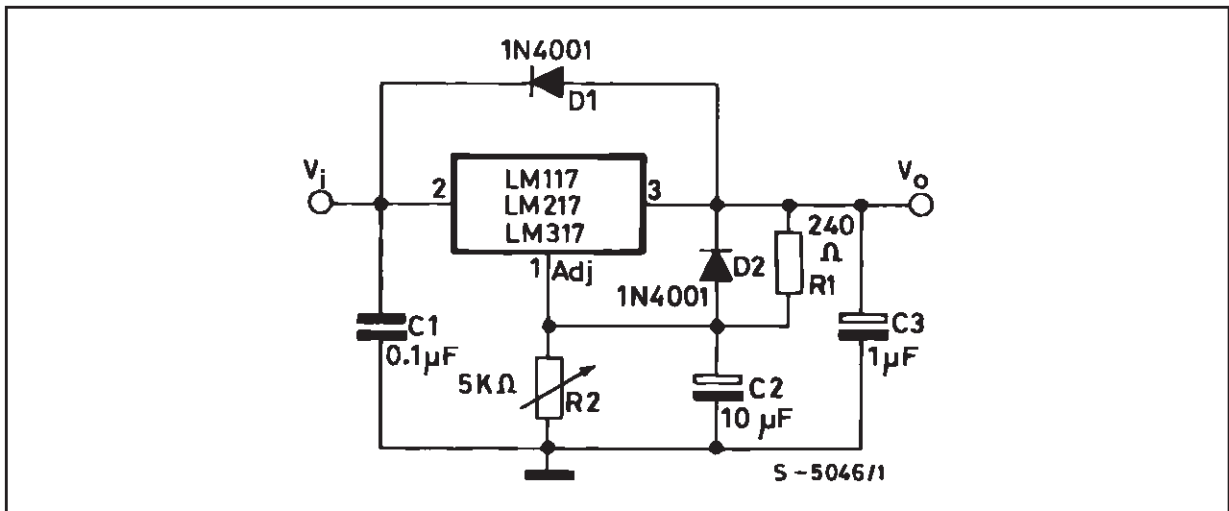

D1 protect the device against input short circuit, while D2 protects against output short circuit for capacitors discharging

Figure 6 : Slow Turn-on 15V Regulator.

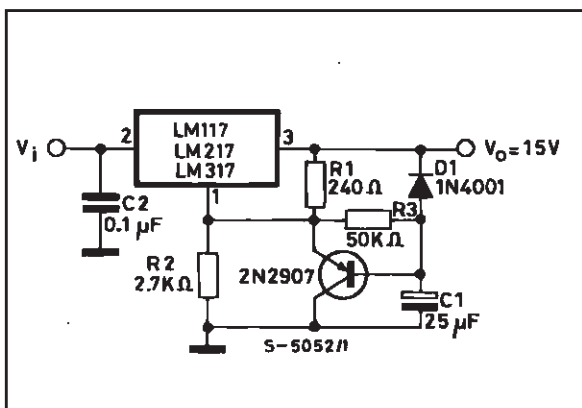

Figure 7 : Current Regulator.

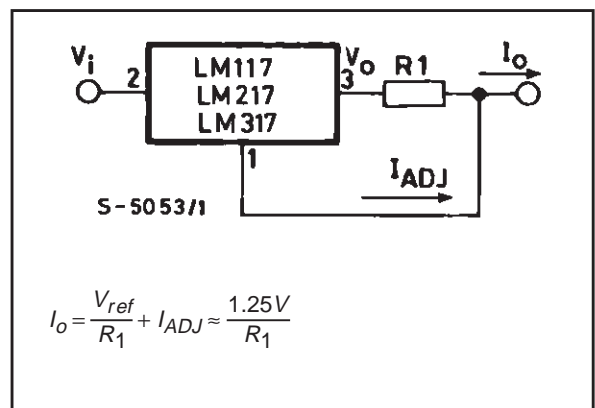

Figure 8 : 5V Electronic Shut-down Regulator

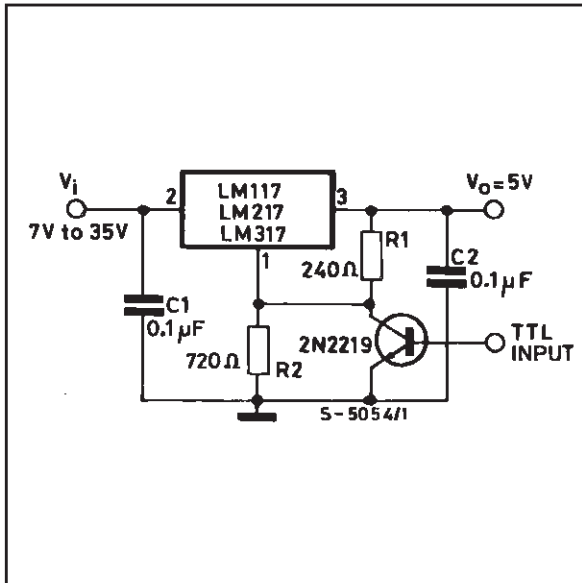

Figure 9 : Digitally Selected Outputs

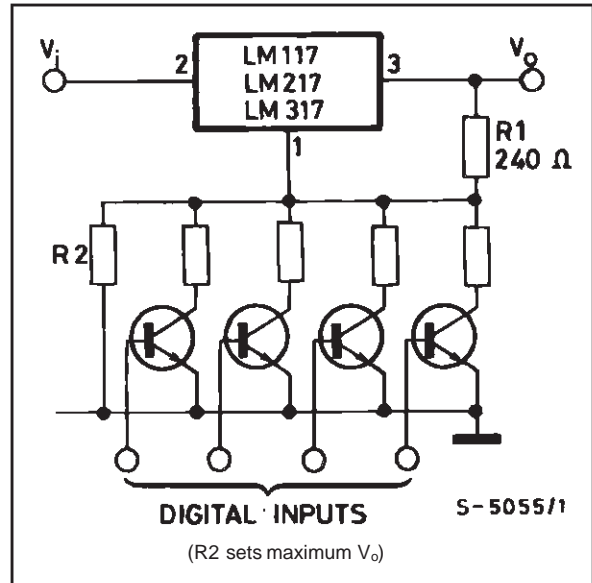

Figure 10 : Battery Charger (12V)

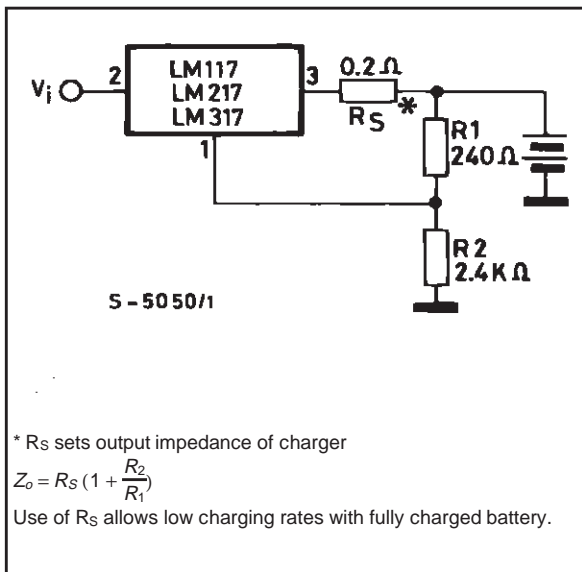
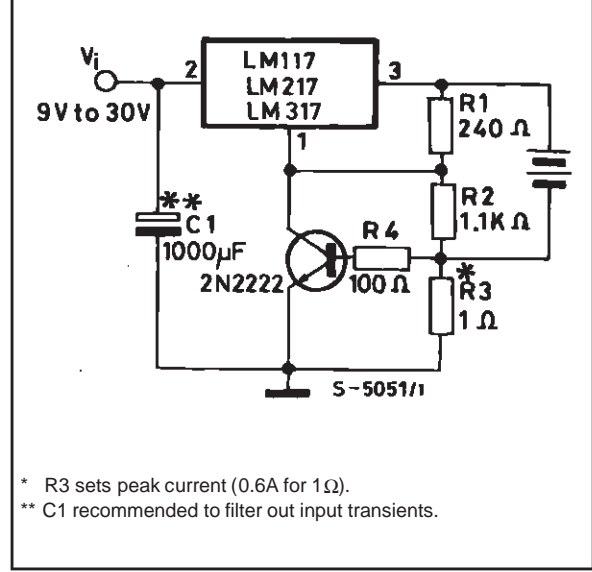
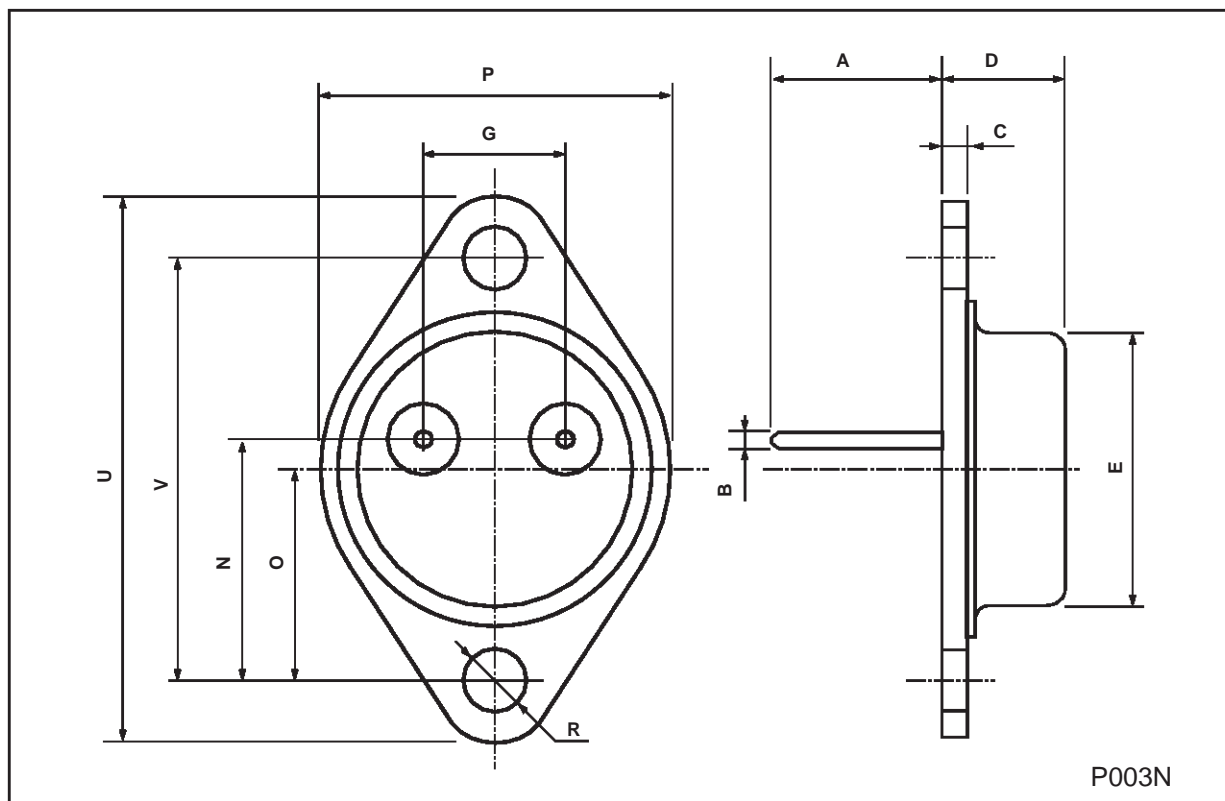

Figure 11 : Current Limited 6V Charger



TO-3 (R) MECHANICAL DATA

DIM.	mm			inch		
	MIN.	TYP.	MAX.	MIN.	TYP.	MAX.
A		11.7			0.460	
B	0.96		1.10	0.037		0.043
C			1.70			0.066
D			8.7			0.342
E			20.0			0.787
G		10.9			0.429	
N		16.9			0.665	
P			26.2			1.031
R	3.88		4.09	0.152		0.161
U			39.50			1.555
V		30.10			1.185	



TO-220 MECHANICAL DATA

DIM.	mm			inch		
	MIN.	TYP.	MAX.	MIN.	TYP.	MAX.
A	4.40		4.60	0.173		0.181
C	1.23		1.32	0.048		0.051
D	2.40		2.72	0.094		0.107
D1		1.27			0.050	
E	0.49		0.70	0.019		0.027
F	0.61		0.88	0.024		0.034
F1	1.14		1.70	0.044		0.067
F2	1.14		1.70	0.044		0.067
G	4.95		5.15	0.194		0.203
G1	2.4		2.7	0.094		0.106
H2	10.0		10.40	0.393		0.409
L2		16.4			0.645	
L4	13.0		14.0	0.511		0.551
L5	2.65		2.95	0.104		0.116
L6	15.25		15.75	0.600		0.620
L7	6.2		6.6	0.244		0.260
L9	3.5		3.93	0.137		0.154
DIA.	3.75		3.85	0.147		0.151

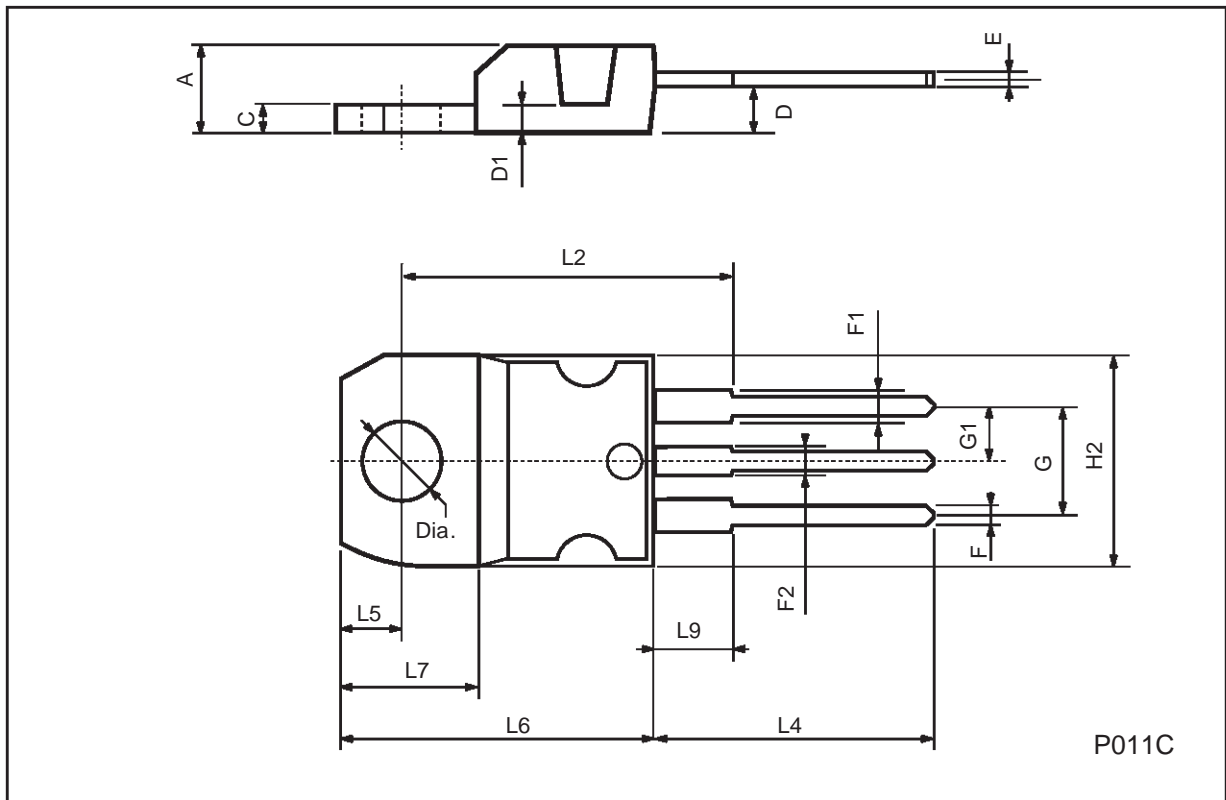

ISOWATT220 MECHANICAL DATA

DIM.	mm			inch		
	MIN.	TYP.	MAX.	MIN.	TYP.	MAX.
A	4.4		4.6	0.173		0.181
B	2.5		2.7	0.098		0.106
D	2.5		2.75	0.098		0.108
E	0.4		0.7	0.015		0.027
F	0.75		1	0.030		0.039
F1	1.15		1.7	0.045		0.067
F2	1.15		1.7	0.045		0.067
G	4.95		5.2	0.195		0.204
G1	2.4		2.7	0.094		0.106
H	10		10.4	0.393		0.409
L2		16			0.630	
L3	28.6		30.6	1.126		1.204
L4	9.8		10.6	0.385		0.417
L6	15.9		16.4	0.626		0.645
L7	9		9.3	0.354		0.366
Ø	3		3.2	0.118		0.126

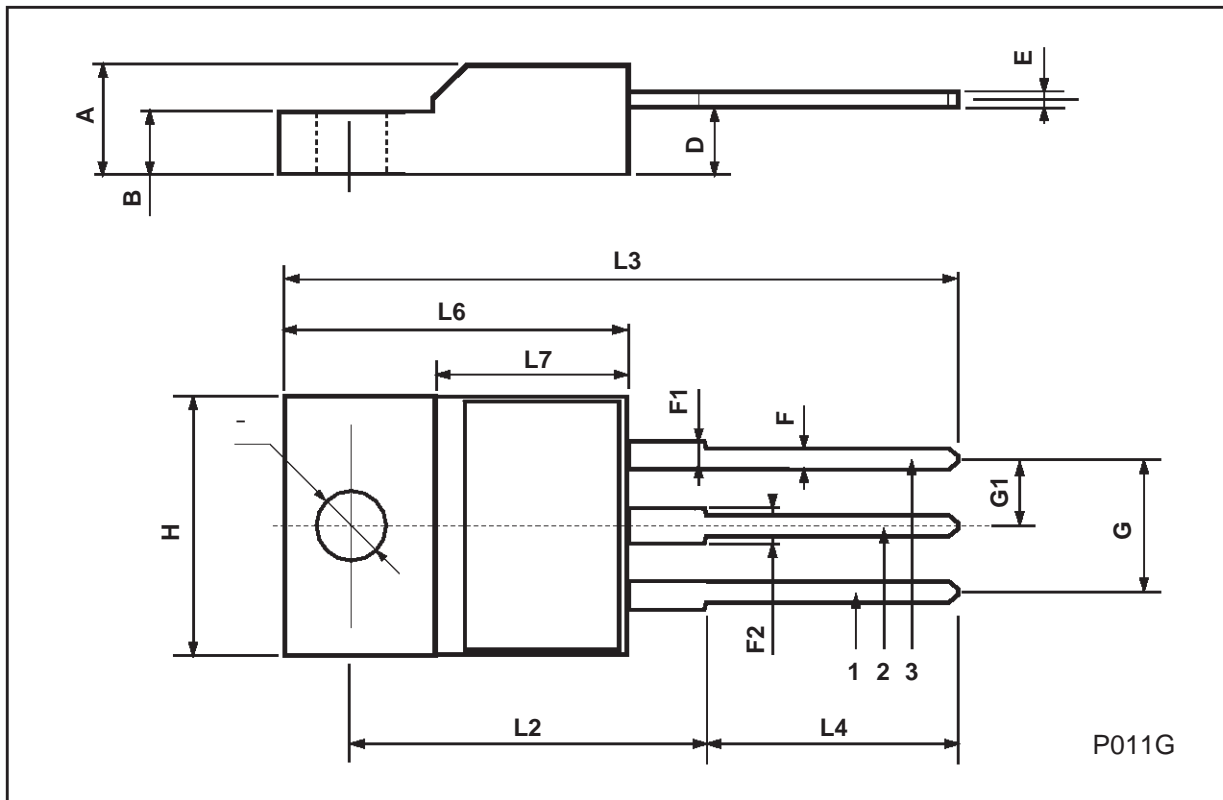

TO-263 (D²PAK) MECHANICAL DATA

DIM.	mm			inch		
	MIN.	TYP.	MAX.	MIN.	TYP.	MAX.
A	4.4		4.6	0.173		0.181
A1	2.49		2.69	0.098		0.106
B	0.7		0.93	0.027		0.036
B2	1.14		1.7	0.044		0.067
C	0.45		0.6	0.017		0.023
C2	1.23		1.36	0.048		0.053
D	8.95		9.35	0.352		0.368
E	10		10.4	0.393		0.409
G	4.88		5.28	0.192		0.208
L	15		15.85	0.590		0.624
L2	1.27		1.4	0.050		0.055
L3	1.4		1.75	0.055		0.068

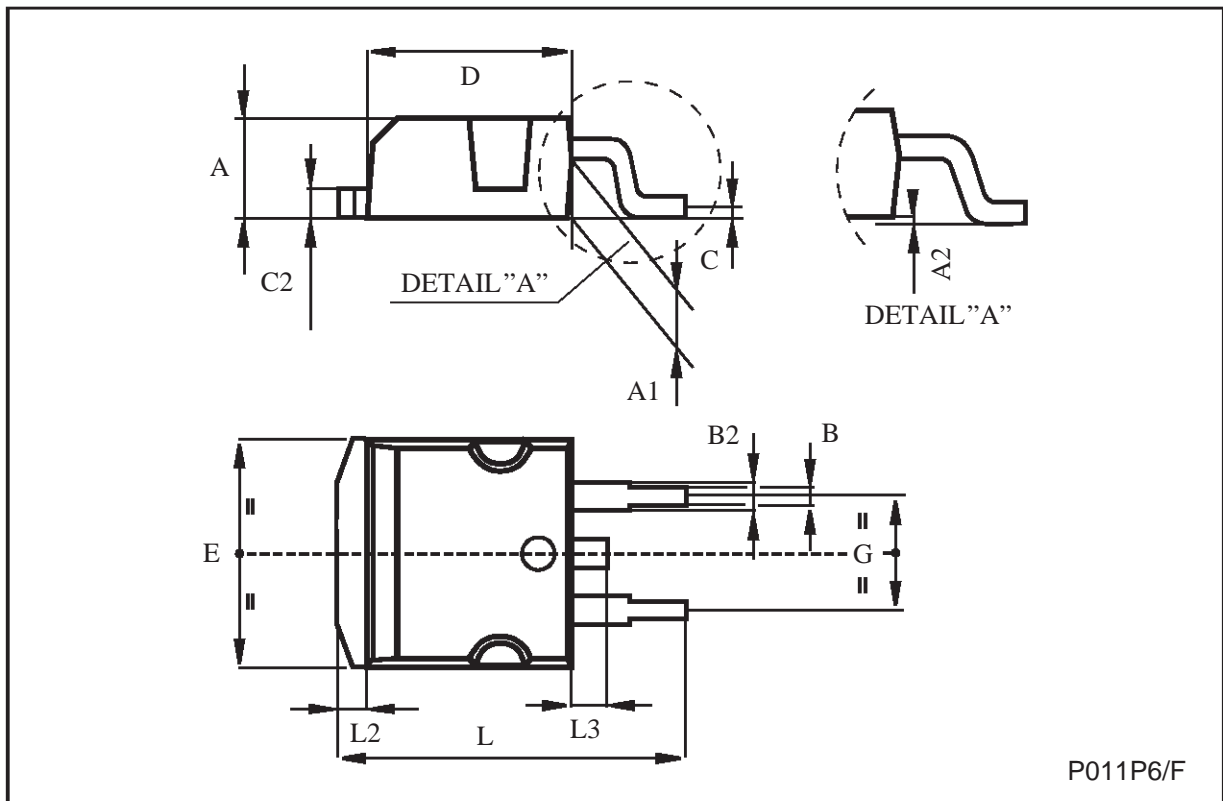

Information furnished is believed to be accurate and reliable. However, STMicroelectronics assumes no responsibility for the consequences of use of such information nor for any infringement of patents or other rights of third parties which may result from its use. No license is granted by implication or otherwise under any patent or patent rights of STMicroelectronics. Specification mentioned in this publication are subject to change without notice. This publication supersedes and replaces all information previously supplied. STMicroelectronics products are not authorized for use as critical components in life support devices or systems without express written approval of STMicroelectronics.

The ST logo is a registered trademark of STMicroelectronics

© 1999 STMicroelectronics – Printed in Italy – All Rights Reserved

STMicroelectronics GROUP OF COMPANIES

Australia - Brazil - China - Finland - France - Germany - Hong Kong - India - Italy - Japan - Malaysia - Malta - Morocco
Singapore - Spain - Sweden - Switzerland - United Kingdom - U.S.A.

<http://www.st.com>