

## LM2794/LM2795

# Current Regulated Switched Capacitor LED Supply with Analog and PWM Brightness Control

### General Description

The LM2794/95 is a fractional CMOS charge-pump that provides four regulated current sources. It accepts an input voltage range from 2.7V to 5.5V and maintains a constant current determined by an external sense resistor.

The LM2794/5 delivers up to 80mA of load current to accommodate four White LEDs. The switching frequency is 325kHz. (min.) to keep the conducted noise spectrum away from sensitive frequencies within portable RF devices.

Brightness can be controlled by both linear and PWM techniques. A voltage between 0V and 3.0V may be applied to the BRGT pin to linearly vary the LED current. Alternatively, a PWM signal can be applied to the SD pin to vary the perceived brightness of the LED. The SD pin reduces the operating current to 2.3 $\mu$ A (typ.) The LM2794 is shut down when the SD pin is low, and the LM2795 is shut down when the SD pin is high.

The LM2794/95 is available in a micro SMD-14 CSP package.

### Features

- Regulated current sources with  $\pm 0.5\%$  matching between any two outputs
- High efficiency 3/2 boost function
- Drives one, two, three or four white LEDs
- 2.7V to 5.5V Input Voltage
- Up to 80mA output current
- Analog brightness control
- Active-low or high shutdown input ('94/95)
- Very small solution size and no inductor
- 2.3 $\mu$ A (typ.) shutdown current
- 325kHz switching frequency (min.)
- Constant Frequency generates predictable noise spectrum
- Standard Micro SMD-14 package: 2.08mm X 2.403mm X 0.845mm High
- Thin Micro SMD-14 package: 2.08mm X 2.403mm X 0.600mm High

### Applications

- White LED Display Backlights
- White LED Keypad Backlights
- 1-Cell Li-Ion battery-operated equipment including PDAs, hand-held PCs, cellular phones

### Basic Application Circuit

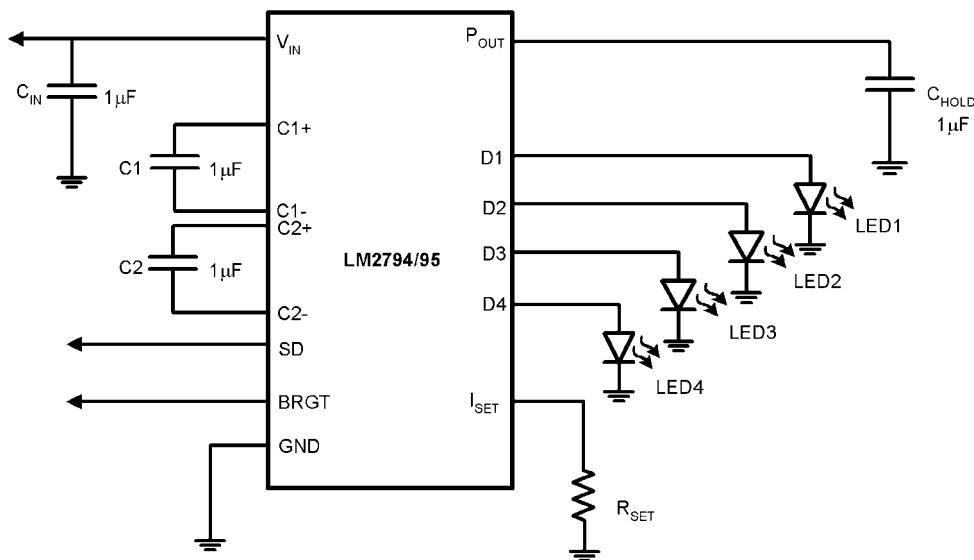

20028503

## Connection Diagram

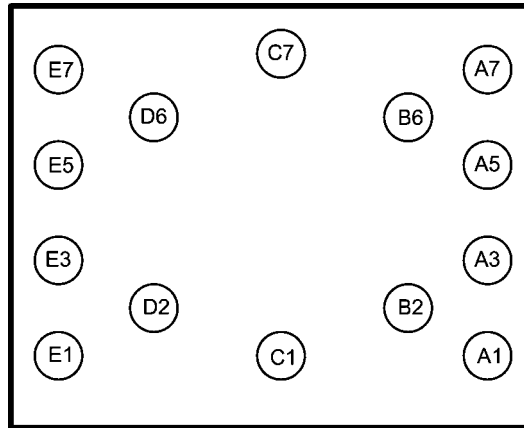

20028523

Bottom View

## Ordering Information

### Standard Micro SMD Package:

Order Number	Shutdown Polarity	Package Number	Package Marking	Supplied As
LM2794BL	Active Low	BLP14EHB	I LOG	250 Units, Tape and Reel
LM2794BLX	Active Low	BLP14EHB	I LOG	3000 Units, Tape and Reel
LM2795BL	Active High	BLP14EHB	I LOJ	250 Units, Tape and Reel
LM2795BLX	Active High	BLP14EHB	I LOJ	3000 Units, Tape and Reel

### Thin Micro SMD Package:

Order Number	Shutdown Polarity	Package Number	Package Marking	Supplied As
LM2794TL	Active Low	TLP14EHA	I LOG	250 Units, Tape and Reel
LM2794TLX	Active Low	TLP14EHA	I LOG	3000 Units, Tape and Reel
LM2795TL	Active High	TLP14EHA	I LOJ	250 Units, Tape and Reel
LM2795TLX	Active High	TLP14EHA	I LOJ	3000 Units, Tape and Reel

## Pin Description

Pin(*)	Name	Function
A1	C1+	Positive terminal of C1
B2	C1-	Negative terminal of C1
C1	V <sub>IN</sub>	Power supply voltage input
D2	GND	Power supply ground input
E1	C2-	Negative terminal of C2
E3,E5,E7,D6	D1-4	Current source outputs. Connect directly to LED
C7	I <sub>SET</sub>	Current Sense Input. Connect 1% resistor to ground to set constant current through LED
B6	BRGT	Variable voltage input controls output current
A7	SD	The LM2794 has an active-low shutdown pin (LOW = shutdown, HIGH = operating). The LM2795 has an active-high shutdown pin (HIGH = shutdown, LOW = operating) that has a pull-up to V <sub>IN</sub> .
A5	C2+	Positive terminal of C2
A3	P <sub>OUT</sub>	Charge pump output

(\*) Note that the pin numbering scheme for the Micro SMD package was revised in April, 2002 to conform to JEDEC standard. Only the pin numbers were revised. No changes to the physical location of the inputs/outputs were made. For reference purpose, the obsolete numbering had C1+ as pin 1, C1- as pin 2, V<sub>IN</sub> as pin 3, GND as pin 4, C2- as pin 5, D1-D4 as pin 6,7,8 & 9, Iset as pin 10, BRGT as pin 11, SD as pin 12, C2+ as pin 13, Pout as pin 14

**Absolute Maximum Ratings** (Note 1)

If Military/Aerospace specified devices are required, please contact the National Semiconductor Sales Office/Distributors for availability and specifications.

$V_{IN}$	-0.5 to 6.2V max
SD	-0.5 to ( $V_{IN}+0.3V$ ) w/ 6.2V max
BRGT	-0.5 to ( $V_{IN}+0.3V$ ) w/ 6.2V max
Continuous Power Dissipation (Note 2)	Internally Limited
$T_{JMAX}$ (Note 2)	135°C

$\theta_{JA}$ (Notes 2, 3)	125°C/W
Storage Temperature	-65°C to +150°C
Lead Temp. (Soldering, 5 sec.)	260°C
ESD Rating (Note 4)	
Human Body Model	2kV
Machine Model	200V

**Operating Conditions**

Input Voltage ( $V_{IN}$ )	2.7V to 5.5V
Ambient Temperature ( $T_A$ )	-30°C to +85°C
Junction Temperature ( $T_J$ )	-30°C to +100°C

**Electrical Characteristics**

Limits in standard typeface are for  $T_J = 25^\circ\text{C}$  and limits in **boldface type** apply over the full **Operating Junction Temperature Range** (-30°C  $\leq T_J \leq$  +100°C). Unless otherwise specified,  $C_1 = C_2 = C_{IN} = C_{HOLD} = 1 \mu\text{F}$ ,  $V_{IN} = 3.6\text{V}$ , BRGT pin = 0V;  $R_{SET} = 124\Omega$ ; LM2794:  $V_{SD} = V_{IN}$  (LM2795:  $V_{SD} = 0\text{V}$ ).

Symbol	Parameter	Conditions	Min	Typ	Max	Units
$I_{DX}$	Available Current at Output Dx	$3.0\text{V} \leq V_{IN} \leq 5.5\text{V}$ $V_{DX} \leq 3.8\text{V}$ BRGT = 50mV	<b>15</b>	16.8		mA
		$2.7\text{V} \leq V_{IN} \leq 3.0\text{V}$ $V_{DX} \leq 3.6\text{V}$ BRGT = 0V	10			mA
		$V_{DX} \leq 3.8\text{V}$ BRGT = 200mV	20			mA
$V_{DX}$	Available Voltage at Output Dx	$3.0\text{V} \leq V_{IN} \leq 5.5\text{V}$ $I_{DX} \leq 15\text{mA}$ BRGT = 50mV	<b>3.8</b>			V
$I_{DX}$	Line Regulation of Dx Output Current	$3.0\text{V} \leq V_{IN} \leq 5.5\text{V}$ $V_{DX} = 3.6\text{V}$	<b>14.18</b>	15.25	<b>16.78</b>	mA
		$3.0\text{V} \leq V_{IN} \leq 4.4\text{V}$ $V_{DX} = 3.6\text{V}$	<b>14.18</b>	15.25	<b>16.32</b>	mA
$I_{DX}$	Load Regulation of Dx Output Current	$V_{IN} = 3.6\text{V}$ $3.0\text{V} \leq V_{DX} \leq 3.8\text{V}$	<b>14.18</b>	15.25	<b>16.32</b>	mA
$I_{D-MATCH}$	Current Matching Between Any Two Outputs	$V_{IN} = 3.6\text{V}$ , $V_{DX} = 3.6\text{V}$		0.5		%
$I_Q$	Quiescent Supply Current	$3.0\text{V} \leq V_{IN} \leq 4.2\text{V}$ , Active, No Load Current $R_{SET} = \text{OPEN}$		5.5	<b>8.2</b>	mA
$I_{SD}$	Shutdown Supply Current	$3.0\text{V} \leq V_{IN} \leq 5.5\text{V}$ , Shutdown		2.3	<b>5</b>	$\mu\text{A}$
$I_{PULL-SD}$	Shutdown Pull-Up Current (LM2795)	$V_{IN} = 3.6\text{V}$		1.5		$\mu\text{A}$
$V_{CP}$	Input Charge-Pump Mode To Pass Mode Threshold			4.7		V
$V_{CPH}$	Input Charge-Pump Mode To Pass Mode Hysteresis	(Note 5)		250		mV
$V_{IH}$	SD Input Logic High (LM2794)	$3.0\text{V} \leq V_{IN} \leq 5.5\text{V}$	1.0			V
	SD Input Logic High (LM2795)		$0.8V_{IN}$			
$V_{IL}$	SD Input Logic Low (LM2794)	$3.0\text{V} \leq V_{IN} \leq 5.5\text{V}$			0.2	V
	SD Input Logic Low (LM2795)				$0.2V_{IN}$	
$I_{LEAK-SD}$	SD Input Leakage Current	$0\text{V} \leq V_{SD} \leq V_{IN}$		100		nA
$R_{BRGT}$	BRGT Input Resistance			240		k $\Omega$
$I_{SET}$	$I_{SET}$ Pin Output Current			$I_{DX}/10$		mA

## Electrical Characteristics (Continued)

Limits in standard typeface are for  $T_J = 25^\circ\text{C}$  and limits in **boldface type** apply over the full **Operating Junction Temperature Range** ( $-30^\circ\text{C} \leq T_J \leq +100^\circ\text{C}$ ). Unless otherwise specified,  $C_1 = C_2 = C_{IN} = C_{HOLD} = 1 \mu\text{F}$ ,  $V_{IN} = 3.6\text{V}$ , BRGT pin = 0V;  $R_{SET} = 124\Omega$ ; LM2794:  $V_{SD} = V_{IN}$  (LM2795:  $V_{SD} = 0\text{V}$ ).

Symbol	Parameter	Conditions	Min	Typ	Max	Units
$f_{SW}$	Switching Frequency (Note 6)	$3.0\text{V} \leq V_{IN} \leq 4.4\text{V}$	<b>325</b>	515	<b>675</b>	kHz

**Note 1:** Absolute maximum ratings indicate limits beyond which damage to the device may occur. Electrical specifications do not apply when operating the device beyond its rated operating conditions.

**Note 2:** Internal thermal shutdown circuitry protects the device from permanent damage. Thermal shutdown engages at  $T_J=150^\circ\text{C}$  (typ.) and disengages at  $T_J=140^\circ\text{C}$  (typ.). D1, D2, D3 and D4 may be shorted to GND without damage.  $P_{OUT}$  may be shorted to GND for 1sec without damage.

**Note 3:** The value of  $\theta_{JA}$  is based on a two layer evaluation board with a dimension of 2in. x1.5in.

**Note 4:** In the test circuit, all capacitors are 1.0 $\mu\text{F}$ , 0.3 $\Omega$  maximum ESR capacitors. Capacitors with higher ESR will increase output resistance, reduce output voltage and efficiency.

**Note 5:** Voltage at which the device switches from charge-pump mode to pass mode or pass mode to charge-pump mode. For example, during pass mode the device output (Pout) follows the input voltage.

**Note 6:** The output switches operate at one eighth of the oscillator frequency,  $f_{OSC} = 1/8f_{SW}$ .

# Typical Performance Characteristics

Unless otherwise specified,  $C_1 = C_2 = C_{IN} = C_{HOLD} = 1\mu F$ ,

$V_{IN} = 3.6V$ ,  $BRGT\ pin = 0V$ ,  $R_{SET} = 124\Omega$ .

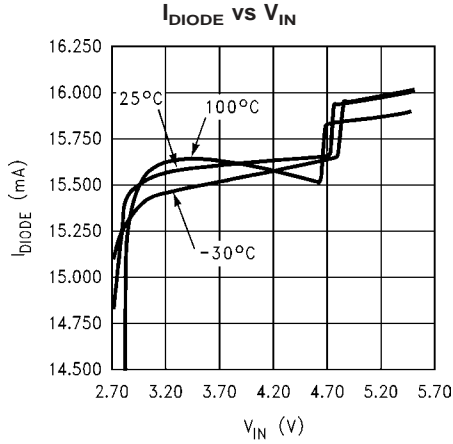

20028512

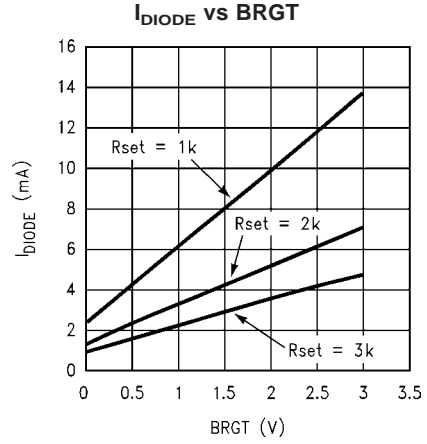

20028509

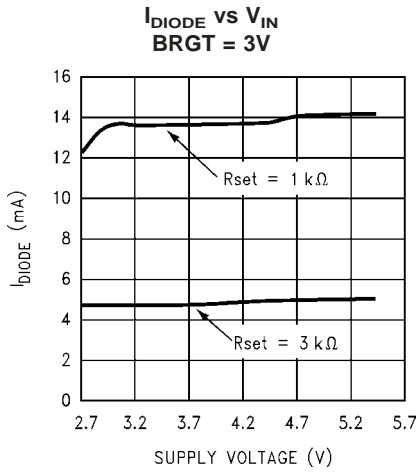

20028507

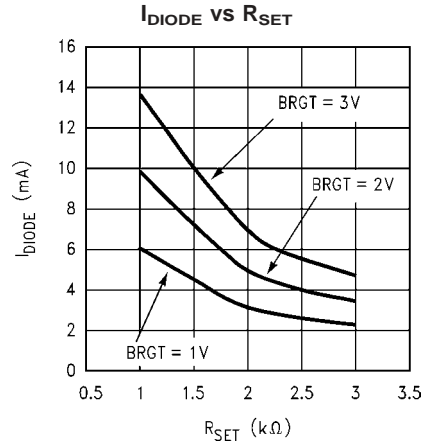

20028508

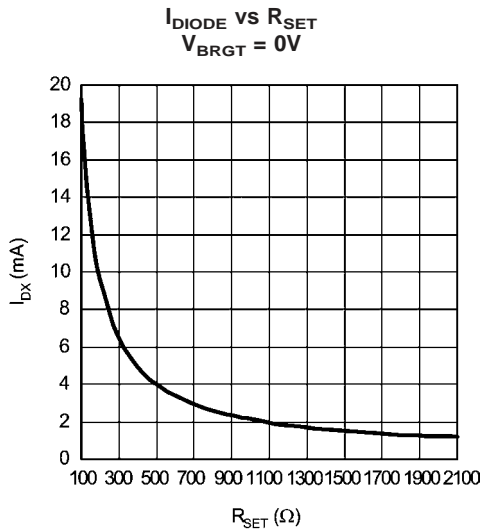

20028541

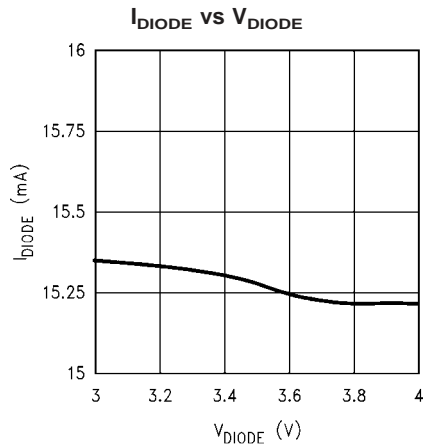

20028524

**Typical Performance Characteristics** Unless otherwise specified,  $C_1 = C_2 = C_{IN} = C_{HOLD} = 1\mu F$ ,  $V_{IN} = 3.6V$ , BRGT pin = 0V,  $R_{SET} = 124\Omega$ . (Continued)

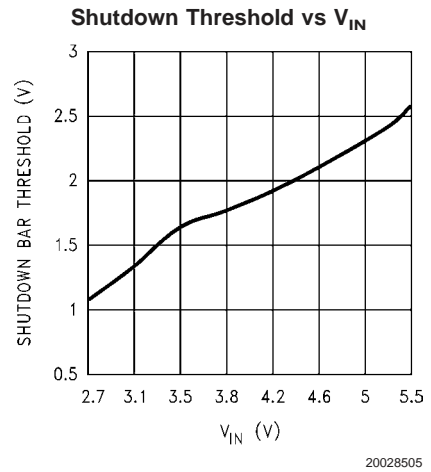
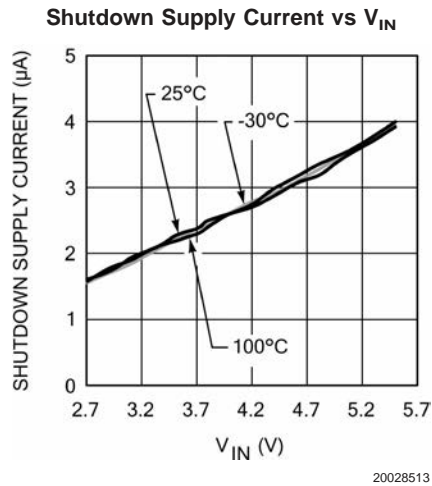
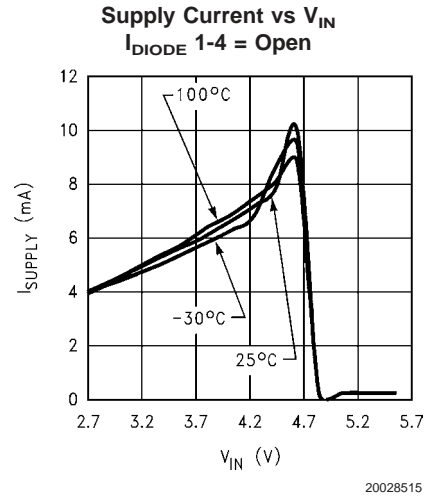
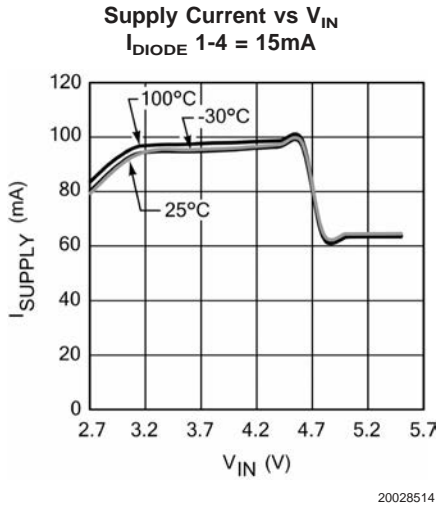
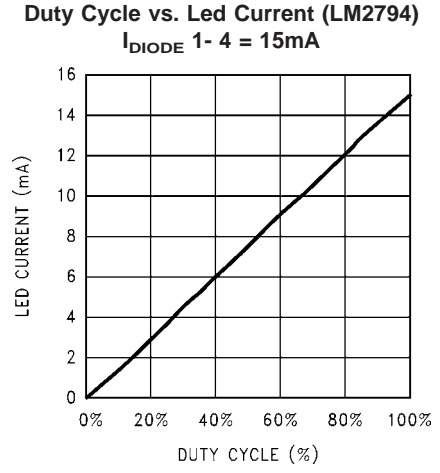
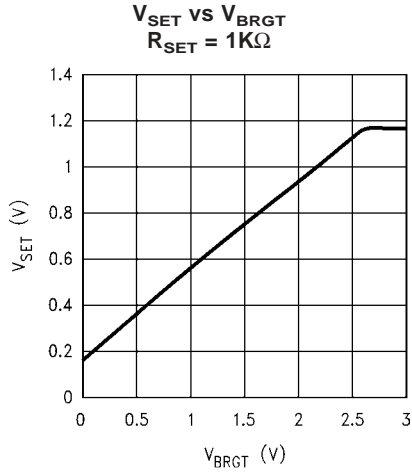

**Typical Performance Characteristics** Unless otherwise specified,  $C_1 = C_2 = C_{IN} = C_{HOLD} = 1\mu F$ ,  $V_{IN} = 3.6V$ , BRGT pin = 0V,  $R_{SET} = 124\Omega$ . (Continued)

**Start-Up Response @  $V_{IN} = 2.7V$  (LM2794)**

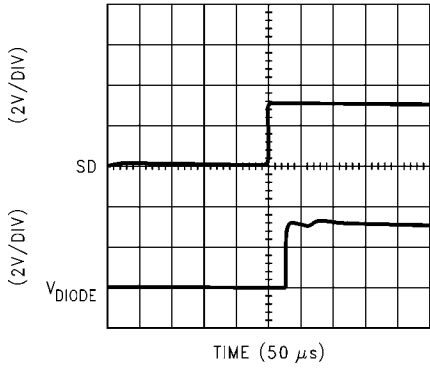

**Start-Up Response @  $V_{IN} = 2.7V$  (LM2795)**

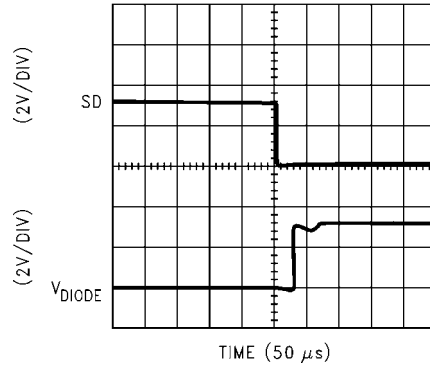

**Start-Up Response @  $V_{IN} = 3.6V$  (LM2794)**

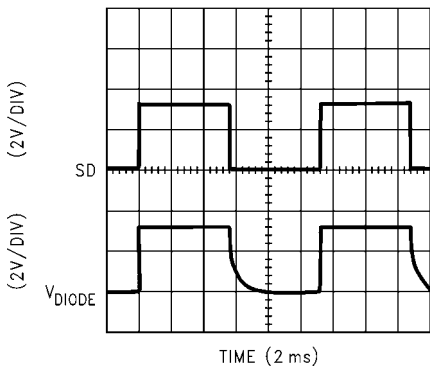

**Start-Up Response @  $V_{IN} = 3.6V$  (LM2795)**

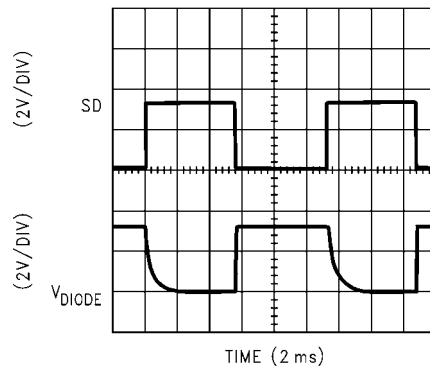

**Start-Up Response @  $V_{IN} = 4.2V$  (LM2794)**

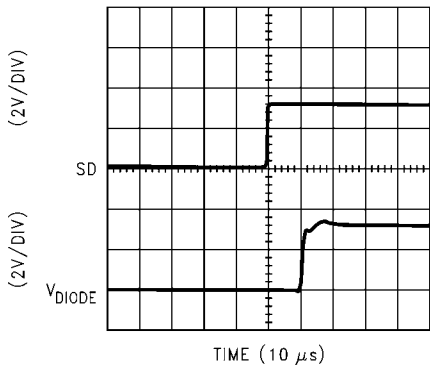

**Start-Up Response @  $V_{IN} = 4.2V$  (LM2795)**

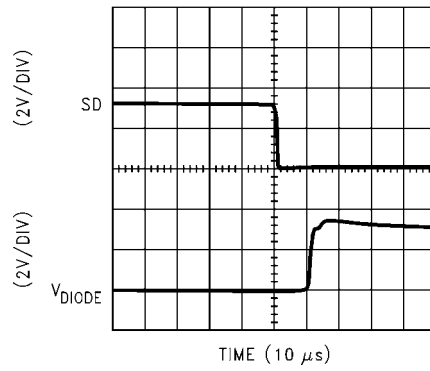

**Typical Performance Characteristics** Unless otherwise specified,  $C_1 = C_2 = C_{IN} = C_{HOLD} = 1\mu F$ ,  $V_{IN} = 3.6V$ , BRGT pin = 0V,  $R_{SET} = 124\Omega$ . (Continued)

**Available Additional Current @  $P_{OUT}$**   
 $I_{DIODE\ 1-4} = 15mA$ ,  $R_{SET} = 124\Omega$

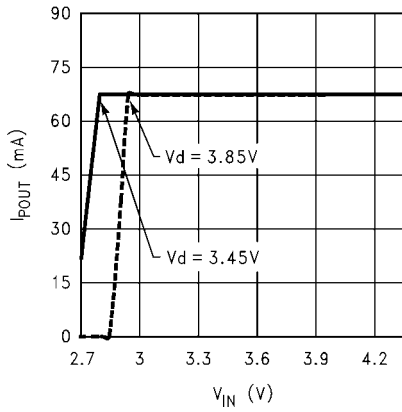

20028531

**Switching Frequency**

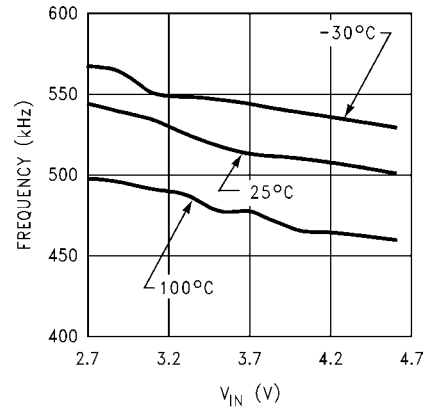

20028516

## Functional Block Diagram

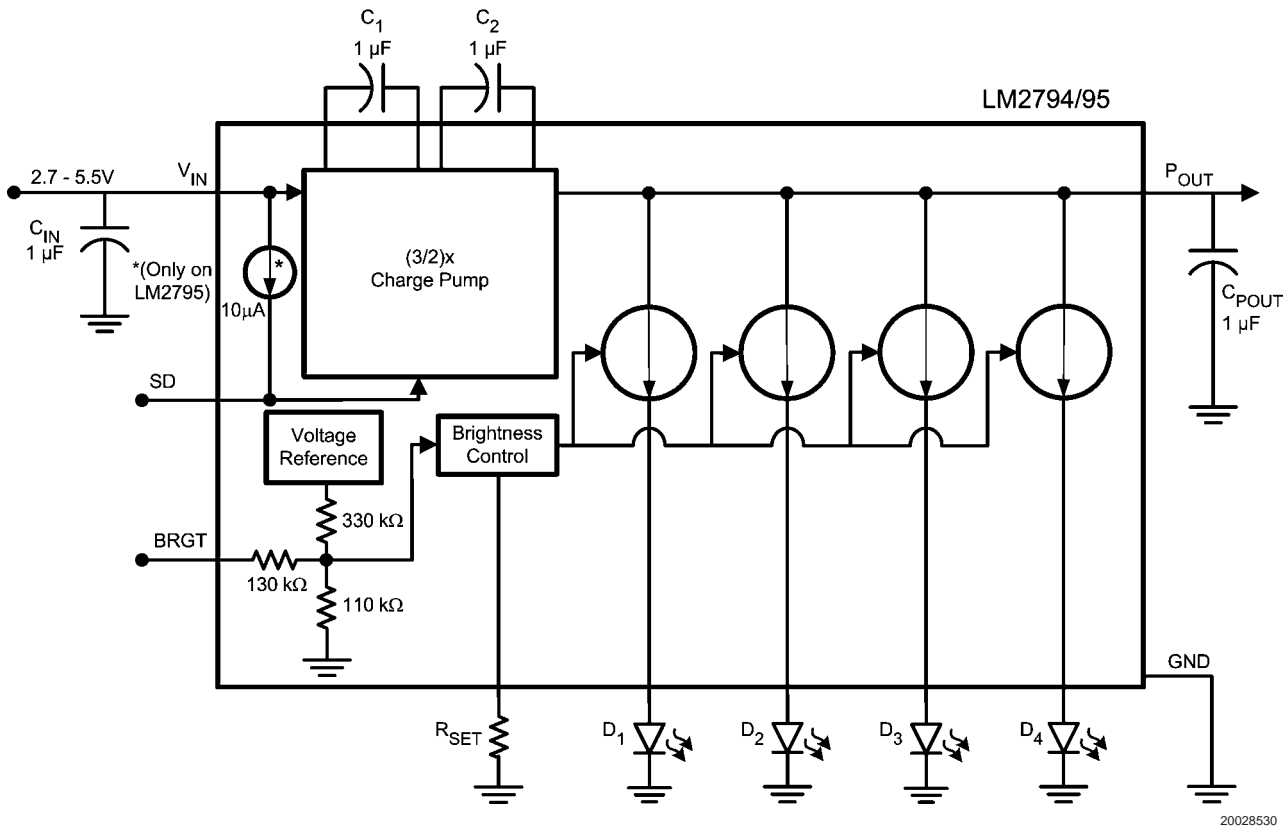

20028530

## Application Information

### CIRCUIT DESCRIPTION

The LM2794/5 is a 1.5x/1x CMOS charge pump with four matched constant current outputs, each capable of driving up to 20mA through White LEDs. This device operates over the extended Li-Ion battery range from 2.7V to 5.5V. The LM2794/5 has four regulated current sources connected to the device's 1.5x charge pump output ( $P_{OUT}$ ). At input voltages below 4.7V (typ.), the charge-pump provides the needed voltage to drive high forward voltage drop White LEDs. It does this by stepping up the  $P_{OUT}$  voltage 1.5 times the input voltage. The charge pump operates in Pass Mode, providing a voltage on  $P_{OUT}$  equal to the input voltage, when the input voltage is at or above 4.7V (typ.). The device can drive up to 80mA through any combination of LEDs connected to the constant current outputs  $D_1$ - $D_4$ .

To set the LED drive current, the device uses a resistor connected to the  $I_{SET}$  pin to set a reference current. This

reference current is then multiplied and mirrored to each constant current output. The LED brightness can then be controlled by analog and/or digital methods. Applying an analog voltage in the range of 0V to 3.0V to the Brightness pin (BRGT) adjusts the dimming profile of the LEDs. The digital technique uses a PWM (Pulse Width Modulation) signal applied to the Shutdown pin (SD). (see  **$I_{SET}$  and BRGT PINS** section).

### SOFT START

Soft start is implemented internally by ramping the reference voltage more slowly than the applied voltage. During soft start, the current through the LED outputs will ramp up in proportion to the rate that the reference voltage is being ramped up.

## Application Information (Continued)

### SHUTDOWN MODE

The shutdown pin (SD) disables the part and reduces the quiescent current to 2.3µA (typ.).

The LM2795 has an active-high shutdown pin (HIGH = shutdown, LOW = operating). An internal pull-up is connected between SD and  $V_{IN}$  of the LM2795. This allows the use of open-drain logic control of the LM2795 shutdown, as shown in *Figure 1*. The LM2795 SD pin can also be driven with a rail-to-rail CMOS logic signal.

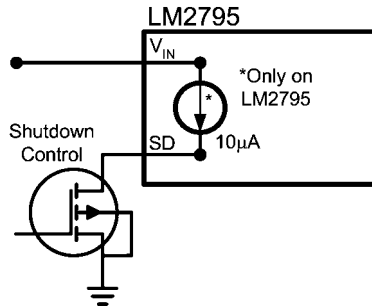

20028536

FIGURE 1. Open-Drain Logic Shutdown Control

The LM2794 has an active-low shutdown pin (LOW = shutdown, HIGH = operating). The LM2794 SD pin can be driven with a low-voltage CMOS logic signal (1.5V logic, 1.8V logic, etc). There is no internal pull-up or pull-down on the SD pin of the LM2794.

### CAPACITOR SELECTION

The LM2794/5 requires 4 external capacitors for proper operation. Surface-mount multi-layer ceramic capacitors are recommended. These capacitors are small, inexpensive and have very low equivalent series resistance (ESR,  $\leq 15\text{m}\Omega$  typ.). Tantalum capacitors, OS-CON capacitors, and aluminum electrolytic capacitors are generally not recommended for use with the LM2794/5 due to their high ESR, as compared to ceramic capacitors.

For most applications, ceramic capacitors with X7R or X5R temperature characteristic are preferred for use with the LM2794/5. These capacitors have tight capacitance tolerance (as good as  $\pm 10\%$ ), hold their value over temperature (X7R:  $\pm 15\%$  over  $-55^\circ\text{C}$  to  $125^\circ\text{C}$ ; X5R:  $\pm 15\%$  over  $-55^\circ\text{C}$  to  $85^\circ\text{C}$ ), and typically have little voltage coefficient. Capacitors with Y5V or Z5U temperature characteristic are generally not recommended for use with the LM2794/5. Capacitors with these temperature characteristics typically have wide capacitance tolerance (+80%, -20%), vary significantly over temperature (Y5V: +22%, -82% over  $-30^\circ\text{C}$  to  $+85^\circ\text{C}$  range; Z5U: +22%, -56% over  $+10^\circ\text{C}$  to  $+85^\circ\text{C}$  range), and have poor voltage coefficients. Under some conditions, a nominal  $1\mu\text{F}$  Y5V or Z5U capacitor could have a capacitance of only  $0.1\mu\text{F}$ . Such detrimental deviation is likely to cause Y5V and Z5U capacitors to fail to meet the minimum capacitance requirements of the LM2794/5. *Table 1* lists suggested capacitor suppliers for the typical application circuit.

TABLE 1. Ceramic Capacitor Manufacturers

Manufacturer	Contact
TDK	www.component.tdk.com
Murata	www.murata.com
Taiyo Yuden	www.t-yuden.com

### LED SELECTION

The LM2794/5 is designed to drive LEDs with a forward voltage of about 3.0V to 4.0V. The typical and maximum diode forward voltage depends highly on the manufacturer and their technology. *Table 2* lists two suggested manufacturers. Forward current matching is assured over the LED process variations due to the constant current output of the LM2794/5.

TABLE 2. White LED Selection

Manufacturer	Contact
Osram	www.osram-os.com
Nichia	www.nichia.com

### $I_{SET}$ AND BRGT PINS

An external resistor,  $R_{SET}$ , is connected to the  $I_{SET}$  pin to set the current to be mirrored in each of the LED outputs. The internal current mirror sets each LED output current with a 10:1 ratio to the current through  $R_{SET}$ . The current mirror circuitry matches the current through each LED to within 0.5%.

In addition to  $R_{SET}$ , a voltage may be applied to the  $V_{BRGT}$  pin to vary the LED current. By adjusting current with the Brightness pin (BRGT), the brightness of the LEDs can be smoothly varied.

Applying a voltage on BRGT between 0 to 3 volts will linearly vary the LED current. Voltages above 3V do not increase the LED current any further. The voltage on the  $V_{BRGT}$  pin is fed into an internal resistor network with a ratio of 0.385. The resulting voltage is then summed with a measured offset voltage of 0.188V, which comes from the reference voltage being fed through a resistor network (See **Functional Block Diagram**). The brightness control circuitry then uses the summed voltage to control the voltage across  $R_{SET}$ . An equation for approximating the LED current is:

$$I_{LED} = \left( \frac{V_{OFFSET} + (V_{BRGT} * 0.385)}{R_{SET}} \right) * (\text{MirrorRatio})$$

$$I_{LED} = \left( \frac{0.188 + (V_{BRGT} * 0.385)}{R_{SET}} \right) * \frac{10}{1} \text{ Amps}$$

20028540

## Application Information (Continued)

### I<sub>LED</sub> CURRENT SELECTION PROCEDURES

The following procedures illustrate how to set and adjust output current levels. For constant brightness or analog brightness control, go to “Brightness control using BRGT”. Otherwise refer to “Brightness control using PWM”.

#### Brightness Control Using PWM

1. Set the BRGT pin to 0V.
2. Determine the maximum desired I<sub>LED</sub> current. Use the I<sub>LED</sub> equation to calculate R<sub>SET</sub> by setting BRGT to 0V or use Table 3 to select a value for R<sub>SET</sub> when BRGT equals 0V.
3. Brightness control can be implemented by pulsing a signal at the SD pin. LED brightness is proportional to the duty cycle (D) of the PWM signal. For linear brightness control over the full duty cycle adjustment range, the PWM frequency (f) should be limited to accommodate the turn-on time (T<sub>ON</sub> = 100μs) of the device.

$$D \times (1/f) > T_{ON}$$

$$f_{MAX} = D_{MIN} \div T_{ON}$$

If the PWM frequency is much less than 100Hz, flicker may be seen in the LEDs. For the LM2794, zero duty cycle will turn off the LEDs and a 50% duty cycle will result in an average I<sub>LED</sub> being half of the programmed LED current. For example, if R<sub>SET</sub> is set to program 15mA, a 50% duty cycle will result in an average I<sub>LED</sub> of 7.5mA. For the LM2795 however, 100% duty cycle will turn off the LEDs and a 50% duty cycle will result in an average I<sub>LED</sub> being half the programmed LED current.

#### Brightness Control Using BRGT

1. Choose the maximum I<sub>LED</sub> desired and determine the max voltage to be applied to the BRGT pin. For constant brightness, set BRGT to a fixed voltage between 0V to 3V.
2. Use Table 3 to determine the value of R<sub>SET</sub> required or use the I<sub>LED</sub> equation above to calculate R<sub>SET</sub>.
3. Use Table 4 as a reference for the dimming profile of the LEDs, when BRGT ranges from 0V to 3V.

TABLE 3. R<sub>SET</sub> Values

BRGT	LED Current			
	5mA	10mA	15mA	20mA
0.0V	374Ω	187Ω	124Ω	93.1Ω
0.5V	768Ω	383Ω	255Ω	191Ω
1.0V	1.15KΩ	576Ω	383Ω	287Ω
1.5V	1.54KΩ	768Ω	511Ω	383Ω
2.0V	1.91KΩ	953Ω	624Ω	475Ω

BRGT	LED Current			
	5mA	10mA	15mA	20mA
2.5V	2.32KΩ	1.15KΩ	768Ω	576Ω
3.0V	2.67KΩ	1.33KΩ	909Ω	665Ω

R<sub>SET</sub> values are rounded off to the nearest 1% standard values.

TABLE 4. LED Current

BRGT	R <sub>SET</sub> Values			
	2.67KΩ	1.33KΩ	909Ω	665Ω
0.0V	0.7mA	1.4mA	2.1mA	2.8mA
0.5V	1.4mA	2.9mA	4.2mA	5.7mA
1.0V	2.1mA	4.3mA	6.3mA	8.6mA
1.5V	2.9mA	5.8mA	8.4mA	11.5mA
2.0V	3.6mA	7.2mA	10.5mA	14.4mA
2.5V	4.3mA	8.7mA	12.7mA	17.3mA
3.0V	5.0mA	10.1mA	14.8mA	20.2mA

### CHARGE PUMP OUTPUT (P<sub>OUT</sub>)

The LM2794/5 charge pump is an unregulated switched capacitor converter with a gain of 1.5. The voltage at the output of the pump (the P<sub>OUT</sub> pin) is nominally 1.5 x V<sub>IN</sub>. This rail can be used to deliver additional current to other circuitry. Figure 2 shows how to connect additional LEDs to P<sub>OUT</sub>. A ballast resistor sets the current through each LED, and LED current matching is dependent on the LED forward voltage matching. Because of this, LEDs driven by P<sub>OUT</sub> are recommended for functions where brightness matching is not critical, such as keypad backlighting.

Since P<sub>OUT</sub> is unregulated, driving LEDs directly off P<sub>OUT</sub> is usually practical only with a fixed input voltage. If the input voltage is not fixed (Li-Ion battery, for example), using a linear regulator between the P<sub>OUT</sub> pin and the LEDs is recommended. National Semiconductor's LP3985-4.5V low-dropout linear regulator is a good choice for such an application.

The voltage at P<sub>OUT</sub> is dependent on the input voltage supplied to the LM2794/5, the total LM2794/5 output current, and the output resistance (R<sub>OUT</sub>) of the LM2794/5 charge pump. Output resistance is a model of the switching losses of the charge pump. Resistances of the internal charge pump switches (MOS transistors) are a primary component of the LM2794/5 output resistance. Typical LM2794/5 output resistance is 3.0Ω. For worst-case design calculations, using an output resistance of 3.5Ω is recommended. (Worst-case recommendation accounts for parameter shifts from part-to-part variation and applies over the full operating temperature range).

## Application Information (Continued)

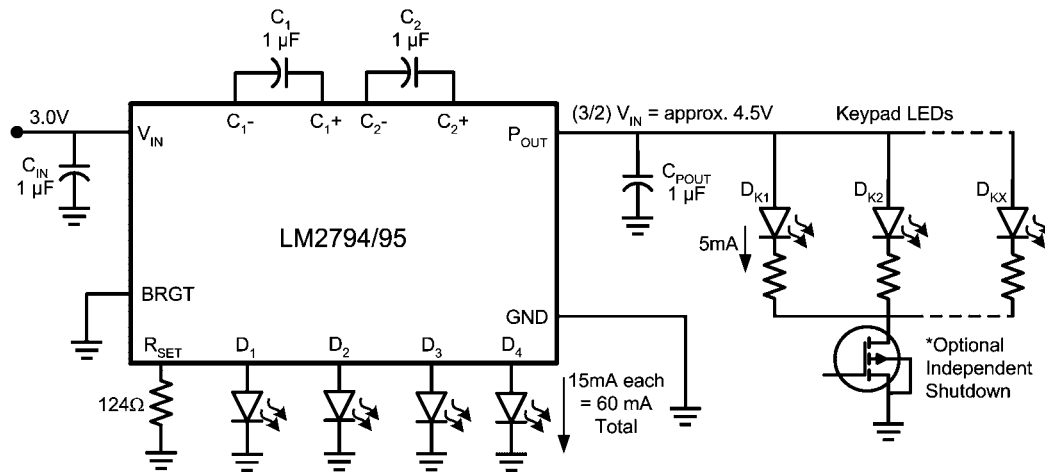

20028535

FIGURE 2. Keypad LEDs Connected to P<sub>OUT</sub>

Output resistance results in droop in the P<sub>OUT</sub> voltage proportional to the amount of current delivered by the pump. The P<sub>OUT</sub> voltage is an important factor in determining the total output current capability of an application. Taking total output current to be the sum of all D<sub>X</sub> output currents plus the current delivered through the P<sub>OUT</sub> pin, the voltage at P<sub>OUT</sub> can be predicted with the following equations:

$$I_{TOTAL} = I_{D1} + I_{D2} + I_{D3} + I_{D4} + I_{POUT}$$

$$V_{POUT} = 1.5 \times V_{IN} - I_{TOTAL} \times R_{OUT}$$

### LED HEADROOM VOLTAGE (V<sub>HR</sub>)

Four current sources are connected internally between P<sub>OUT</sub> and D<sub>1</sub>-D<sub>4</sub>. The voltage across each current source, (V<sub>POUT</sub> - V<sub>DX</sub>), is referred to as headroom voltage (V<sub>HR</sub>). The current sources require a sufficient amount of headroom voltage to be present across them in order to regulate properly. Minimum required headroom voltage is proportional to the current flowing through the current source, as dictated by the equation:

$$V_{HR-MIN} = k_{HR} \times I_{DX}$$

The parameter k<sub>HR</sub>, typically 20mV/mA in the LM2794/5, is a proportionality constant that represents the ON-resistance of the internal current mirror transistors. For worst-case design calculations, using a k<sub>HR</sub> of 25mV/mA is recommended. (Worst-case recommendation accounts for parameter shifts from part-to-part variation and applies over the full operating temperature range). Figure 3 shows how output current of the LM2794/5 varies with respect to headroom voltage.

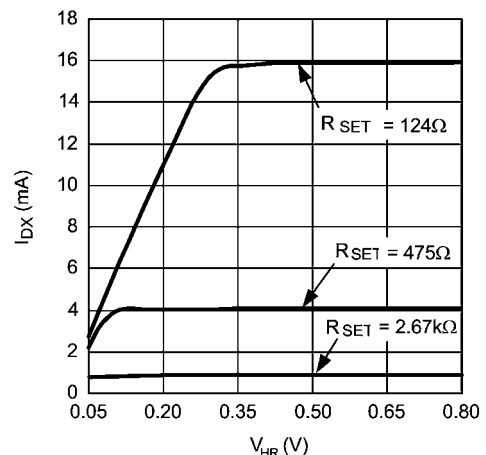

20028539

FIGURE 3. I<sub>LED</sub> vs V<sub>HR</sub>  
4 LEDs, V<sub>IN</sub> = 3.0V

On the flat part of the graph, the currents regulate properly as there is sufficient headroom voltage for regulation. On the sloping part of the graph the headroom voltage is too small, the current sources are squeezed, and their current drive capability is limited. Changes in headroom voltage from one output to the next, possible with LED forward voltage mismatch, will result in different output currents and LED brightness mismatch. Thus, operating the LM2794/5 with insufficient headroom voltage across the current sources should be avoided.

## Application Information (Continued)

### OUTPUT CURRENT CAPABILITY

The primary constraint on the total current capability is the headroom voltage requirement of the internal current sources. Combining the  $V_{POUT}$  and  $V_{HR}$  equations from the previous two sections yields the basic inequality for determining the validity of an LM2794/5 LED-drive application:

$$V_{POUT} = 1.5 \times V_{IN} - I_{TOTAL} \times R_{OUT}$$

$$V_{HR-MIN} = k_{HR} \times I_{DX}$$

$$V_{POUT} - V_{DX} \geq V_{HR-MIN}$$

$$1.5 \times V_{IN} - I_{TOTAL} \times R_{OUT} - V_{DX} \geq (k_{HR} \times I_{DX})$$

Rearranging this inequality shows the estimated total output current capability of an application:

$$I_{TOTAL} \leq [(1.5 \times V_{IN-MIN}) - V_{DX-MAX} - (k_{HR} \times I_{DX})] \div R_{OUT}$$

Examining the equation above, the primary limiting factors on total output current capability are input and LED forward voltage. A low input voltage combined with a high LED voltage may result in insufficient headroom voltage across the current sources, causing them to fall out of regulation. When the current sources are not regulated, LED currents will be below desired levels and brightness matching will be highly dependent on LED forward voltage matching.

Typical LM2794/5 output resistance is  $3.0\Omega$ . For worst-case design calculations, using an output resistance of  $3.5\Omega$  is recommended. LM2794/5 has a typical  $k_{HR}$  constant of  $20\text{mV/mA}$ . For worst-case design calculations, use  $k_{HR} = 25\text{mV/mA}$ . (Worst-case recommendations account for parameter shifts from part-to-part variation and apply over the full operating temperature range).  $R_{OUT}$  and  $k_{HR}$  increase slightly with temperature, but losses are typically offset by the negative temperature coefficient properties of LED forward voltages. Power dissipation and internal self-heating may also limit output current capability but is discussed in a later section.

### PARALLEL Dx OUTPUTS FOR INCREASED CURRENT DRIVE

Outputs  $D_1$  through  $D_4$  may be connected together in any combination to drive higher currents through fewer LEDs. For example in *Figure 4*, outputs  $D_1$  and  $D_2$  are connected together to drive one LED while  $D_3$  and  $D_4$  are connected together to drive a second LED.

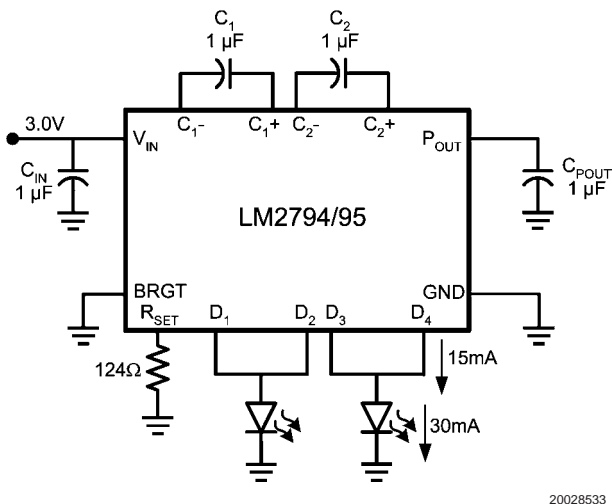

FIGURE 4. Two Parallel Connected LEDs

With this configuration, two parallel current sources of equal value provide current to each LED.  $R_{SET}$  and  $V_{BRGT}$  should therefore be chosen so that the current through each output is programmed to 50% of the desired current through the parallel connected LEDs. For example, if 30mA is the desired drive current for 2 parallel connected LEDs,  $R_{SET}$  and  $V_{BRGT}$  should be selected so that the current through each of the outputs is 15mA. Other combinations of parallel outputs may be implemented in similar fashions, such as in *Figure 5*.

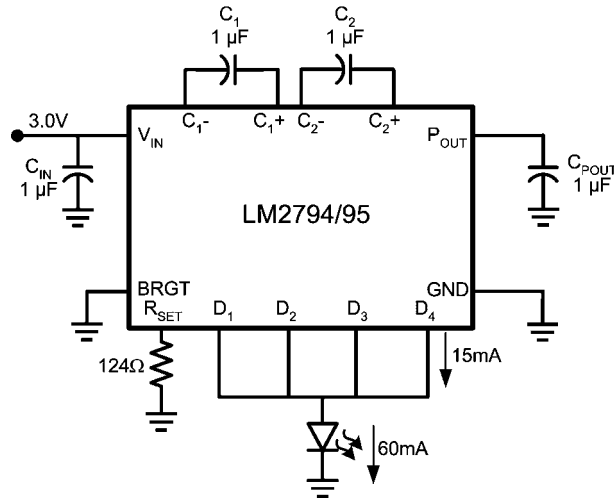

FIGURE 5. One Parallel Connected LED

Connecting outputs in parallel does not affect internal operation of the LM2794/95 and has no impact on the Electrical Characteristics and limits previously presented. The available diode output current, maximum diode voltage, and all other specifications provided in the Electrical Characteristics table apply to parallel output configurations, just as they do to the standard 4-LED application circuit.

### THERMAL PROTECTION

When the junction temperature exceeds  $150^\circ\text{C}$  (typ.), the LM2794/5 internal thermal protection circuitry disables the part. This feature protects the device from damage due to excessive power dissipation. The device will recover and operate normally when the junction temperature falls below  $140^\circ\text{C}$  (typ.). It is important to have good thermal conduction with a proper layout to reduce thermal resistance.

### POWER EFFICIENCY

*Figure 6* shows the efficiency of the LM2794/5. The change in efficiency shown by the graph comes from the transition from Pass Mode to a gain of 1.5.

Efficiency (E) of the LM2794/5 is defined here as the ratio of the power consumed by LEDs ( $P_{LED}$ ) to the power drawn from the input source ( $P_{IN}$ ). In the equations below,  $I_Q$  is the quiescent current of the LM2794/5,  $I_{LED}$  is the current flowing through one LED,  $V_{LED}$  is the forward voltage at that LED current, and N is the number of LEDs connected to the regulated current outputs. In the input power calculation, the 1.5 represents the switched capacitor gain configuration of the LM2794/5.

$$P_{LED} = N \times V_{LED} \times I_{LED}$$

$$P_{IN} = V_{IN} \times I_{IN}$$

$$P_{IN} = V_{IN} \times (1.5 \times N \times I_{LED} + I_Q)$$

## Application Information (Continued)

$$E = (P_{LED} \div P_{IN})$$

Efficiency, as defined here, is in part dependent on LED voltage. Variation in LED voltage does not affect power consumed by the circuit and typically does not relate to the brightness of the LED. For an advanced analysis, it is recommended that power consumed by the circuit ( $V_{IN} \times I_{IN}$ ) be evaluated rather than power efficiency. Figure 7 shows the power consumption of the LM2794/5 Typical Application Circuit.

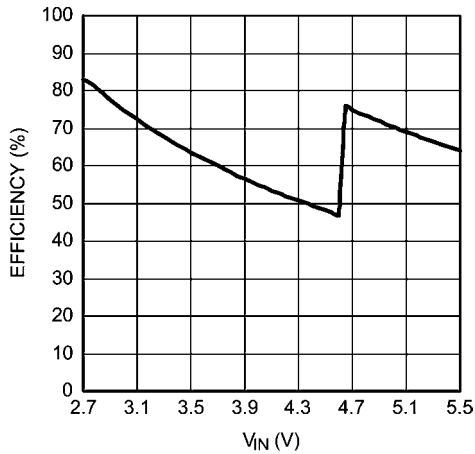

**FIGURE 6. Efficiency vs V<sub>IN</sub>**  
4 LEDs, V<sub>LED</sub> = 3.6V, I<sub>LED</sub> = 15mA

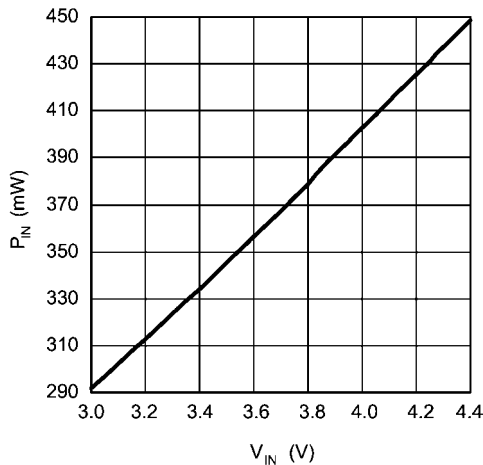

**FIGURE 7. P<sub>IN</sub> vs V<sub>IN</sub>**  
4 LEDs, 2.5 ≤ V<sub>DX</sub> ≤ 3.9V, I<sub>DX</sub> = 15mA

## POWER DISSIPATION

The power dissipation ( $P_{DISSIPATION}$ ) and junction temperature ( $T_J$ ) can be approximated with the equations below.  $P_{IN}$  is the power generated by the 1.5x charge pump,  $P_{LED}$  is the power consumed by the LEDs,  $P_{POUT}$  is the power provided through the P<sub>OUT</sub> pin,  $T_A$  is the ambient temperature, and  $\theta_{JA}$  is the junction-to-ambient thermal resistance for the micro SMD-14 package.  $V_{IN}$  is the input voltage to the LM2794/5,  $V_{DX}$  is the LED forward voltage,  $I_{DX}$  is the programmed LED current, and  $I_{POUT}$  is the current drawn through P<sub>OUT</sub>.

$$P_{DISSIPATION} = P_{IN} - P_{LED} - P_{POUT}$$

$$= [1.5 \times V_{IN} \times (4I_{DX} + I_{POUT})] - (V_{DX} \times 4I_{DX}) - (1.5 \times V_{IN} \times I_{POUT})$$

$$T_J = T_A + (P_{DISSIPATION} \times \theta_{JA})$$

The junction temperature rating takes precedence over the ambient temperature rating. The LM2794/5 may be operated outside the ambient temperature rating, so long as the junction temperature of the device does not exceed the maximum operating rating of 100°C. The maximum ambient temperature rating must be derated in applications where high power dissipation and/or poor thermal resistance causes the junction temperature to exceed 100°C.

## MICRO SMD MOUNTING

The LM2794/5 is a 14-bump micro SMD with a bump size of 300 micron diameter. The micro SMD package requires specific mounting techniques detailed in National Semiconductor Application Note (AN-1112). NSMD (non-solder mask defined) layout pattern is recommended over the SMD (solder mask defined) since the NSMD requires larger solder mask openings over the pad size as opposed to the SMD. This reduces stress on the PCB and prevents possible cracking at the solder joint. For best results during assembly, alignment ordinals on the PC board should be used to facilitate placement of the micro SMD device. Micro SMD is a wafer level chip size package, which means the dimensions of the package are equal to the die size. As such, the micro SMD package lacks the plastic encapsulation characteristics of the larger devices and is sensitive to direct exposure to light sources such as infrared, halogen, and sun light. The wavelengths of these light sources may cause unpredictable operation.



## Physical Dimensions inches (millimeters) unless otherwise noted (Continued)

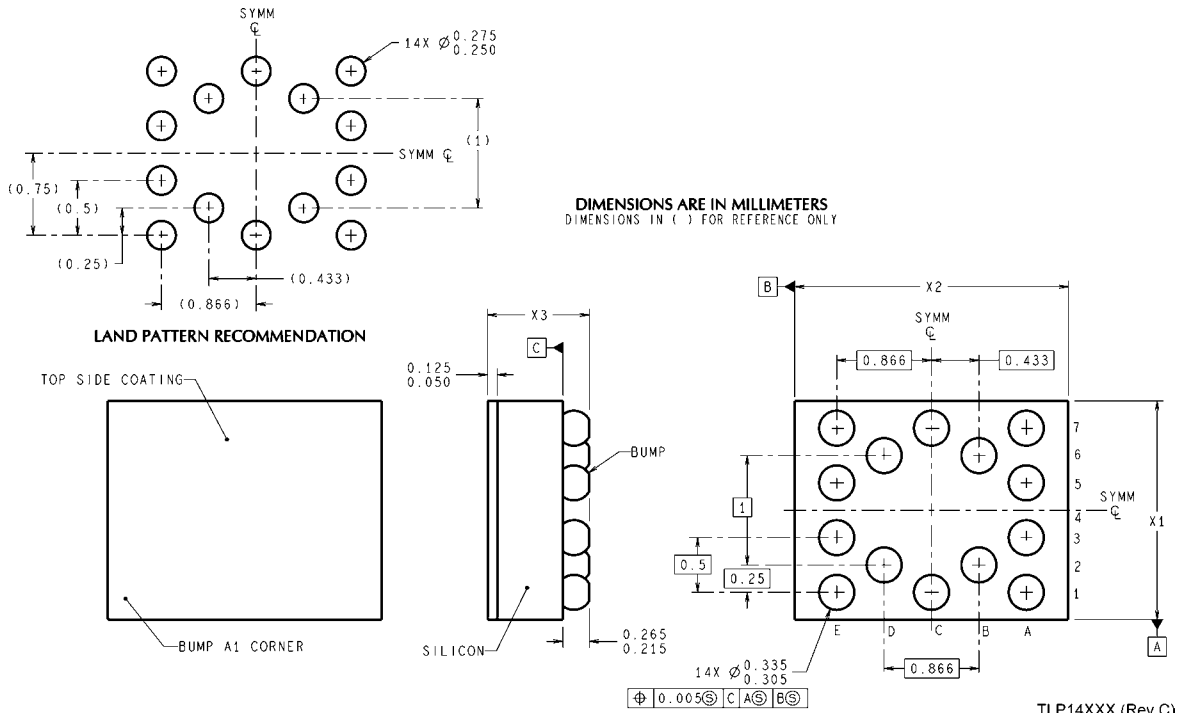

**Thin Micro SMD Package**  
For Ordering, Refer to Ordering Information Table  
NS Package Number TLP14EHA

The dimensions for X1, X2, X3 are given as:

- X1 = 2.098mm ± 0.030mm
- X2 = 2.403mm ± 0.030mm
- X3 = 0.600mm ± 0.075mm

### LIFE SUPPORT POLICY

NATIONAL'S PRODUCTS ARE NOT AUTHORIZED FOR USE AS CRITICAL COMPONENTS IN LIFE SUPPORT DEVICES OR SYSTEMS WITHOUT THE EXPRESS WRITTEN APPROVAL OF THE PRESIDENT AND GENERAL COUNSEL OF NATIONAL SEMICONDUCTOR CORPORATION. As used herein:

1. Life support devices or systems are devices or systems which, (a) are intended for surgical implant into the body, or (b) support or sustain life, and whose failure to perform when properly used in accordance with instructions for use provided in the labeling, can be reasonably expected to result in a significant injury to the user.
2. A critical component is any component of a life support device or system whose failure to perform can be reasonably expected to cause the failure of the life support device or system, or to affect its safety or effectiveness.

### BANNED SUBSTANCE COMPLIANCE

National Semiconductor certifies that the products and packing materials meet the provisions of the Customer Products Stewardship Specification (CSP-9-111C2) and the Banned Substances and Materials of Interest Specification (CSP-9-111S2) and contain no "Banned Substances" as defined in CSP-9-111S2.



**National Semiconductor**  
Americas Customer  
Support Center  
Email: new.feedback@nsc.com  
Tel: 1-800-272-9959

**National Semiconductor**  
Europe Customer Support Center  
Fax: +49 (0) 180-530 85 86  
Email: europe.support@nsc.com  
Deutsch Tel: +49 (0) 69 9508 6208  
English Tel: +44 (0) 870 24 0 2171  
Français Tel: +33 (0) 1 41 91 8790

**National Semiconductor**  
Asia Pacific Customer  
Support Center  
Email: ap.support@nsc.com

**National Semiconductor**  
Japan Customer Support Center  
Fax: 81-3-5639-7507  
Email: jpn.feedback@nsc.com  
Tel: 81-3-5639-7560

www.national.com