

LM1014 Motor Speed Regulator

General Description

The LM1014 is a monolithic integrated circuit specifically designed to provide a low cost motor speed regulator for low voltage DC motors.

- Remote pause control
- Saturation voltage 0.1V
- Motor connected to ground for ease of RF suppression
- Motor torque compensation
- Low current consumption

Features

- 5V to 20V operating voltage range
- Short circuit protection

Functional Block Diagram and Typical Connection

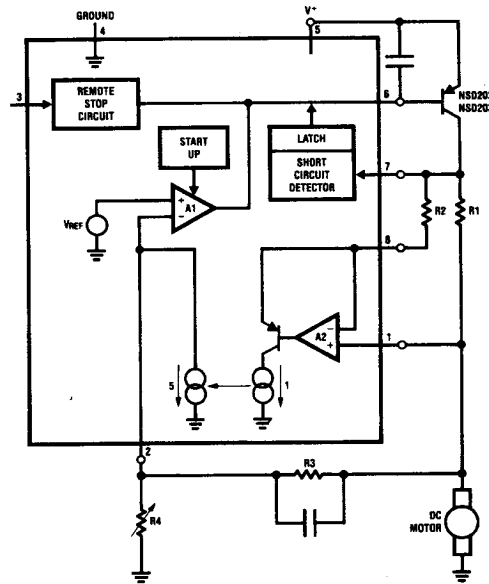

TL/H/6159-1

Connection Diagram

Dual-In-Line Package

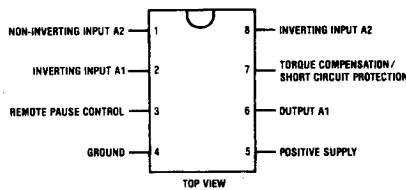

Order Number LM1014N-2
See NS Package N08E

TL/H/6159-2

Absolute Maximum Ratings

Supply Voltage	24V	Storage Temperature Range	-65 to +150°C
Operating Temperature Range	-20 to +70°C	Lead Temp. (Soldering, 10 seconds)	300°C

Electrical Characteristics (Note 1)

Parameter	Conditions	Min	Typ	Max	Units	Comments
Supply Voltage Range		5.0		20.0	V	
Supply Current	Current into Pin 5		6.0	8.0	mA	
Reference Voltage			1.33		V	0.3 mV/°C
Line Regulation of Reference Voltage	V _S = 5V to V _S = 20V Pin 2			2.0	% V _{REF}	
Remote Stop Current	Current into Pin 3 when Grounded		125	200	μA	(Note 2)
Output Current A1	V _S = 5V Pin 2 Gnd	15	40		mA	Current into Pin 7
Short Circuit Current Limit	R1 = 1Ω		1.4		A	(Note 3)
Motor Sense	R1 = 1Ω, R2 = 200Ω					
Current Deviation	Current into Pin 2: I ₂		±3.0		%	(I ₂ /I _m - 1) Exclusive of External Components Tolerances

Note 1: Unless otherwise specified, 5V ≤ V_S ≤ 20V and -15°C ≤ T_A ≤ 55°C.

Note 2: The remote stop is activated by grounding pin 3. The motor restarts after disconnection of the ground connection.

Note 3: The current limit is set by resistor R1, i.e., I = 1.4V/R1. When the output current exceeds this limit, the drive to the output transistor is switched off by a latch circuit. The motor can only be restarted after interruption of the supply voltage.

Typical Performance Characteristics/Application

1. The output voltage V_M is given by:

$$V_M = V_{REF} \left(1 + \frac{R_3}{R_4}\right) + I_M \frac{R_1 R_3}{5R_2}$$

2. R1, R3, R52 must be equal to dynamic motor winding resistance R_M in order to keep the speed constant during load torque variations.

3. Parameter of the motor used for the test results shown below:

R_M = 16.3Ω and back e.m.f. = 3.25V @ 2000 r.p.m.; torque constant 5.9 mA/mNm; External components: R1 = 1Ω Cu, R2 = 200Ω and R3 = 16 kΩ; V_{REF} = 1.33V

C_{BE} = 2.2 μF and C3 = 0.47 μF.

Parameter	Conditions	Max
Motor Speed Deviation (Voltage)	V _S = 5V to 10V V _S = 5V to 20V	±0.5% ±1.0%
Motor Speed Deviation (Load)	I _M = 25 mA to 125 mA	±1.0%
Motor Speed Deviation (Temperature)	T = +5°C to +35°C T = -15°C to +55°C	1.0% 3.0%

Schematic Diagram

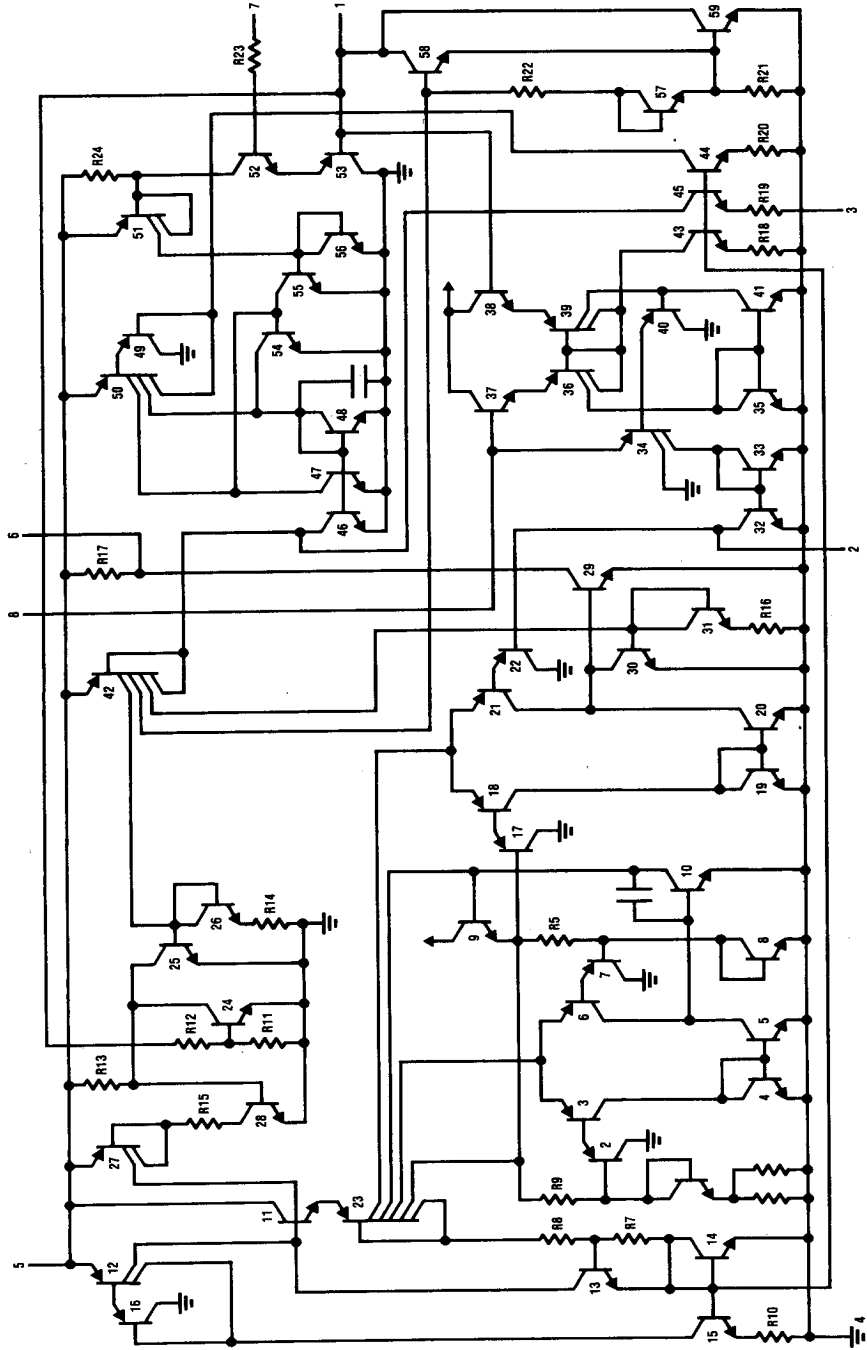

TL/H/6159-3

Application Hints

This circuit has been primarily designed for cassette tape recorders, but is suitable for all low voltage DC motors, and performs the functions of motor speed control, remote stop (pause) and output short circuit protection. The circuit achieves good speed regulation under conditions of supply voltage, torque and temperature variations. Five components, a PNP pass transistor and four resistors, are required to match the circuit to the motor. As these are external to the IC a very wide range of motor characteristics can be accommodated.

Motor speed control is by means of a negative output impedance voltage regulator. The negative output impedance is a function of the external resistors.

If the output current exceeds a preset limit, the base drive to the external PNP transistor is switched off and can only be restarted after reconnection of the supply voltage. The remote stop is activated by closing a DC switch.

System Description

The voltage across the terminals of a DC motor is given by:

$$V_M = E_0 + R_M I_M$$

E_0 = back e.m.f. - proportional to speed

I_M = motor current - proportional to load torque

R_M = motor winding resistance

The regulator must therefore be a source whose voltage can be controlled to maintain the desired back e.m.f., with a negative output resistance whose value equals the motor winding resistance in order to maintain the desired speed during torque variations. (See Figure 1)

A block diagram of the system is shown in Figure 2 with the external components connected. The circuit comprises of a stable voltage reference source, V_{ref} , two high gain differential amplifiers, A_1 and A_2 , short circuit detector + latch and remote stop circuit.

Amplifier A_2 is a high gain differential - input amplifier. (DC collector current: 125 μ A). Feedback through T_1 maintains the potentials at the input terminals 9 and 10 equal, therefore the collector current of T_1 will be in the ratio of R_1/R_2 of the motor current I_M . This current is mirrored (5 : 1) and will be supplied via R_3 . Amplifier A_2 has been designed to work with its inputs at or near the supply voltage.

Amplifier A_1 is also a high gain differential amplifier, but with Darlington inputs. (DC collector current :280 μ A). Feedback through T_2 , R_1 , R_3 and R_4 maintains the potential at pin 1 equal to V_{ref} . The total current through resistor R_3 will be:

$$\frac{V_{ref}}{R_4} + \frac{I_M R_1}{5R_2}$$

The output voltage V_M is thus given by:

$$V_M = V_{ref} \left(1 + \frac{R_3}{R_4} \right) + I_M \frac{R_1 R_3}{5R_2}$$

Therefore by varying R_3/R_4 a no load voltage V_0 can be supplied which equals the back e.m.f. E_0 of the motor at the desired speed. The value of the negative resistance R_0 is given by:

$$R_1 \left(\frac{R_3}{5R_2} \right)$$

The increase in output voltage V_M due to an increase in motor current is given by $\Delta I_M R_0$. The increase in the voltage drop across the motor winding resistor R_M is $\Delta I_M R_M$. In order to keep the speed constant during load torque variations the resistance R_0 must be equal to R_M .

The reference voltage source is based on the bandgap regulator principle⁽¹⁾ and comprises transistors T_1 to T_{10} . The reference voltage is given by:

$$V_{ref} = V_{be1} + V_T \left(1 + \frac{R_9}{R_6} \ln \frac{R_9}{R_5} \right) \text{ with } \frac{R_9}{R_5} = 10 \text{ with } V_T = \frac{kT}{q}$$

The bandgap regulator is driven from an internally generated 3.8 V regulator. This regulator comprises of T_{11}/T_{16} , T_{23} and resistors R_7 and R_8 .

Resistors R_{13} and R_{15} , transistors T_{27} and T_{28} serve the sole purpose of starting this regulator. It only needs to supply enough base current to T_{11} to develop 600 mV across R_7 to ensure start-up. This start-up network is disabled by transistor T_{24} as soon as the output voltage exceeds 3V. Resistors R_{11} and R_{12} are used to sense the output voltage for this purpose.

Current limiting is provided by transistors T_{51} , T_{52} and T_{53} . When the voltage across the external resistor R_1 , connected between pin 8 and 10, becomes high enough to turn on T_{52} and T_{53} (approximately 1.4V), current source T_{51} turns on transistor T_{55} and the latch circuit changes state, i.e., T_{47} turns on. Hence transistor T_{30} is turned on by current source T_{42} and sinks all the base current supplied to T_{29} , thereby switching off the external transistor. Transistor T_{25} holds off the start-up circuit. The latch can only be reset by interruption of the supply voltage. The latch circuit is supplied with equal currents from two collectors of T_{50} . The purpose of the capacitor connected to the base of T_{47} is to ensure that the latch always starts in the "T₄₇ off and T₅₄ on" state.

The remote stop is activated by connecting pin 4 to ground. Transistor T_{45} (collector current 180 μ A) activates current source T_{42} . Transistor T_{30} is driven into saturation by T_{42} , switching off the base drive to the external transistor. At the same time, the Darlington connected transistors T_{58} and T_{59} discharge the capacitors of the motorfilter and transistor T_{25} holds off the start-up circuit. After disconnecting pin 4, current source T_{42} turns off and transistor T_{29} will supply the maximum base drive to restart the motor.

- (1) R. J. Widlar. "New Developments in IC Voltage Regulators" IEEE Journal of Solid-State Circuits, February 1971.

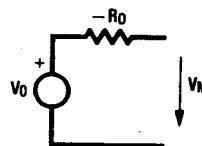
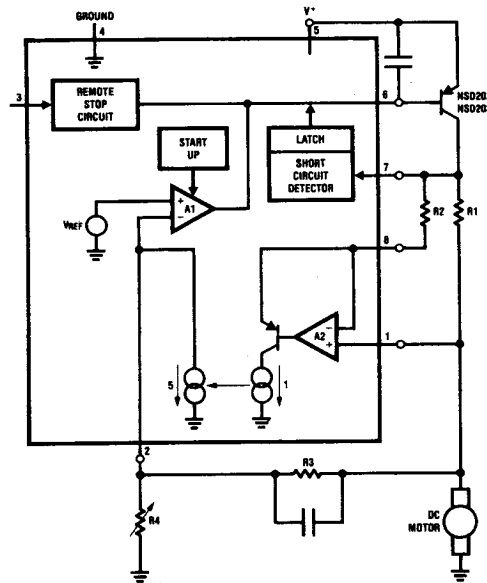

FIGURE 1.

TL/H/6159-4

System Description



TL/H/6159-1

FIGURE 2. Block Diagram

- To ensure stable operation of the system the feedback loop requires compensation capacitors between the base-emitter of the power pass transistor and across R_3 (to smooth current spikes caused by commutator brushes).

Recommended values: $C_{be} = 2.2 - 10 \text{ mF}$

$$C_3 = 0.47 - 1 \mu\text{F}$$

- To minimize the voltage drop between the supply line and the motor, resistor R_1 should be kept to a very low value.

Recommended values: $R_1 = 1 - 5 \Omega$

$$R_2 = 200 \Omega$$

- The output current limit is set by R_1 :

$$I_{\text{limit}} \approx 1.4v/r_1$$

- An improved performance of the system for supply voltage variations can be achieved by connecting a resistor between pin 1 and the supply voltage line. ($V_{\text{ref 3}}$ and $V_{\text{ref 4}}$ only).

Recommended values: $R(V_{\text{ref 3}}) = 6.8 \text{ M}\Omega$

$$R(V_{\text{ref 4}}) = 4 \text{ M}\Omega$$

- The overall temperature performance of the regulator system is primarily determined by the matching of the

temperature coefficient of the motor voltage and the output voltage V_M . Ideally dR_O/dT is made equal to dR_M/dT and dV_O/dT to dE_O/dT . The temperature coefficient of V_O is a multiple of the temperature coefficient of the reference voltage V_{ref} . Four reference voltages are available, two with a negative - and two with a positive temperature coefficient.

Since dR_M/dT is positive, a copper sensing resistor R_1 (assuming R_2 and R_3 are both of the same type) will then give optimum speed regulation over the full temperature range.

Alternatively, a sensing resistor R_1 with a more negative coefficient than that of R_M can be employed e.g. carbon but then a reference voltage with a positive temperature coefficient must be used. However, care must be taken that the resistance $R_1 R_3/5R_2$ never becomes more than R_M , otherwise the system will overcompensate for torque changes and can become unstable. Therefore, when employing a sensing resistor with a negative temperature coefficient, R_O must be made smaller than R_M (factor 0.9). This will degrade the torque regulation accordingly.