

LH1061AB/AAC High-Voltage, Solid-State Relay

Description

The LH1061AB/AAC High-Voltage, Solid-State Relay is a double-pole, single-throw, normally open switch (2 Form A) that can replace electromechanical relays in many applications. The relay features logic-level input control of isolated high-voltage switch outputs. The output is rated at 200 V and can handle loads up to 110 mA. The relay can switch both ac and dc loads and is ideal for audio frequency or dc applications. Typical ON-resistance at 50 mA is 12 Ω.

The LH1061AB/AAC Relay consists of a GaAlAs LED that optically couples control signals to a monolithic integrated circuit. Optical coupling provides 1500 Vrms of input/output isolation. The integrated circuit is a dielectrically isolated, high-voltage die comprised of photodiode arrays, switch control circuitry, and high-voltage DMOS transistor switches.

In operation, the device is exceptionally linear up to 75 mA. Beyond 75 mA, the incremental resistance decreases, thereby minimizing internal power dissipation. Overload currents are clamped at 250 mA by internal current limiting. An extended clamp condition, which increases relay temperature, results in a reduction in clamp current, thereby further reducing internal power dissipation and preserving the relay's integrity. This relay is packaged in an 8-pin, plastic DIP (LH1061AB) or in an 8-pin, surface-mount, gull-wing configuration (LH1061AAC).

Features

- 1500 Vrms input/output isolation
- High-surge capability
- Low ON-resistance
- Clean, bounce-free switching
- Low power consumption
- Monolithic IC reliability

Applications

- Telephone switchhook
- High-voltage testers
- Industrial controls
- Isolation switching

Functional Diagram

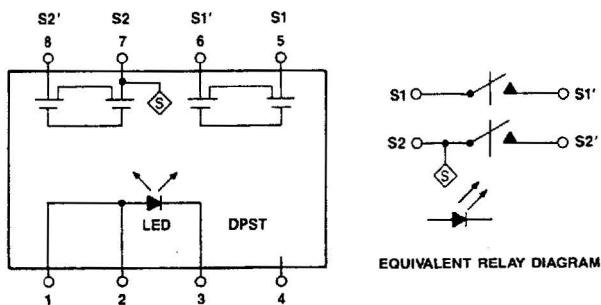

Pin Diagram

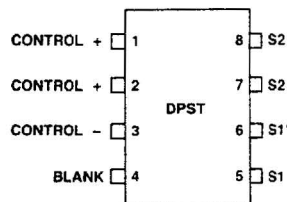

LH1061AB/AAC High-Voltage, Solid-State Relay

Absolute Maximum Ratings

At 25 °C

Stresses exceeding the values listed under Absolute Maximum Ratings can cause permanent damage to the device. This is an absolute stress rating only. Functional operation of the device at these or any other conditions in excess of those indicated in the operational sections of this data sheet is not implied. Exposure to maximum-rating conditions for extended periods of time can adversely affect the device reliability.

Rating	Symbol	Value	Unit
Ambient Operating Temperature Range	TA	-40 to +85	°C
Storage Temperature Range	Tstg	-40 to +100	°C
Pin Soldering Temperature (t = 7 s max.)	TS	270	°C
Input/Output Isolation Voltage (t = 60 s min.)	VISO	1500	Vrms
LED Input Ratings:			
Continuous forward current	IF	20	mA
Reverse voltage	VR	10	V
Output Operation:			
dc or peak ac load voltage ($I_L \leq 50 \mu A$)	VL	200	V
Continuous dc load current	IL	110	mA
Power Dissipation	PDISS	600	mW

Recommended Operating Conditions

TA = 25 °C unless otherwise specified

Parameter	Symbol	Min	Typ	Max	Unit
LED Forward Current for Switch Turn-on (TA = -40 °C to +85 °C)	IFon	6	10	20	mA
Continuous dc Load Current (each pole operating independently)	IL	—	140	165	mA
Continuous dc Load Current (each pole, two poles operating simultaneously)	IL	—	75	110	mA

Pin Descriptions

Pin	Symbol	Name/Function
1 2 3	Control + Control + Control -	These pins are the positive and negative inputs respectively to the control LED. An appropriate amount of current through the LED closes the circuit path between S and S'.
5, 6 7, 8	S S'	These pins are the switch outputs. The pin designated as S represents one side of a relay pole. The pin designated as S' is the complementary side of a relay pole. S2 is electrically connected to the device substrate. To achieve lowest dv/dt sensitivity and optimum turn-on/off performance, connect S2 to the lowest circuit potential.
4	Blank	This pin can be used as a tie-point for external components. Voltage on this pin should not exceed 300 V.

Characteristics

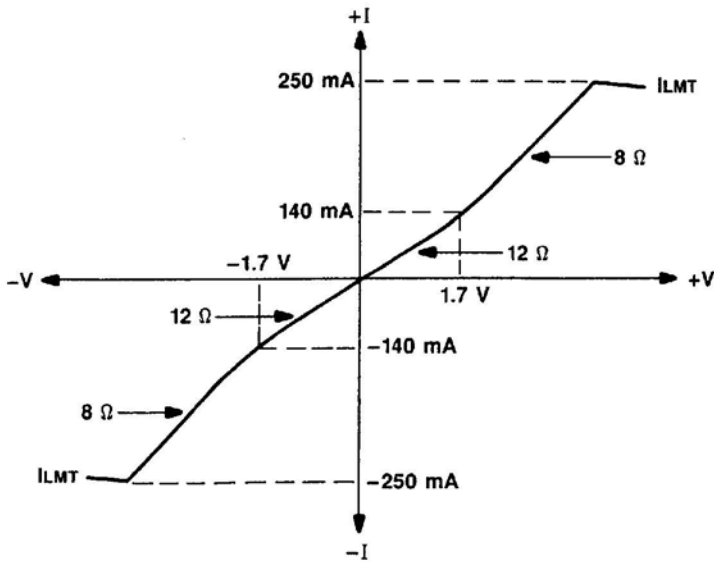

Figure 1. Typical ON Characteristics

Electrical Characteristics $T_A = 25^\circ\text{C}$

Minimum and maximum values are testing requirements. Typical values are characteristics of the device and are the result of engineering evaluations. Typical values are for information purposes only and are not part of the testing requirements.

Characteristics	Symbol	Test Condition	Min	Typ	Max	Unit
LED Forward Current for Switch Turn-on	I_{Fon}	I_L (min) = 110 mA, $V_L = \pm 5\text{ V}$, $t = 10\text{ ms}$ (See Figure 2.)	—	1.5	2.5	mA
LED Forward Current for Switch Turn-off	I_{Foff}	$I_F = 0.2\text{ mA}$, $V_L = \pm 250\text{ V}$ (See Figure 2.)	0.2	1.4	—	mA
LED Forward Voltage	V_F	$I_F = 10\text{ mA}$	1.15	1.22	1.45	V
ON-resistance	R_{ON}	$I_F = 5\text{ mA}$, $I_L = \pm 50\text{ mA}$ (See Figure 3.)	8	12	15	Ω
Current Limit	I_{LMT}	$I_F = 5\text{ mA}$, $V_L = \pm 5\text{ V}$, $t = 10\text{ ms}$ (See Figure 4.)	220	250	350	mA
Output Off-state Leakage Current	—	$I_F = 0$, $V_L = \pm 100\text{ V}$ (See Figure 4.)	—	0.03	200	nA
Turn-on Time	t_{on}	$I_F = 5\text{ mA}$, $V_L = +150\text{ V}$, $R_L = 4\text{ k}\Omega$ (See Figure 5.)	—	2.0	3.0	ms
Turn-off Time	t_{off}	$I_F = 5\text{ mA}$, $V_L = +150\text{ V}$, $R_L = 4\text{ k}\Omega$ (See Figure 5.)	—	1.5	3.0	ms
Feedthrough Capacitance Pin 5 to 6, Pin 7 to 8	—	$I_F = 0$, $V_L = 4\text{ Vp-p}$, 1 kHz	—	35	—	pF
Pole-to-Pole Capacitance (S1 - S2)	—	$I_F = 0\text{ mA}$, $f = 1\text{ MHz}$	—	4.5	—	pF
Pole-to-Pole ON-resistance Matching (S1 - S2)	—	$I_F = 5\text{ mA}$, $I_L = 50\text{ mA}$	—	0.1	0.4	$\Delta\Omega$

Test Circuits

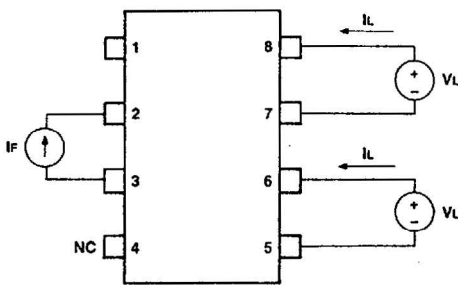

IF	VL	Measure	Parameter
2.5 mA	±5 V	IL	If $ IL \geq I_L$ (min), then IFon is good.
0.2 mA	±250 V	IL	If $ IL < 5 \mu A$, then IOff is good.

Figure 2. Test Circuit for LED Forward Current for Switch Turn-On/Turn-Off

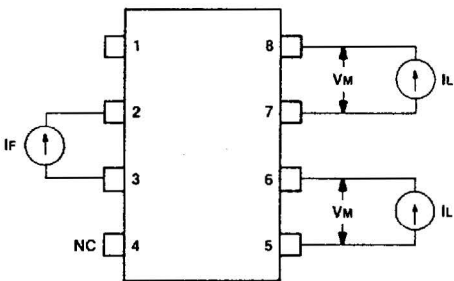

IF	IL	Measure	Parameter
5.0 mA	±50 mA	±VM	ON-resistance = $\frac{ VM }{50 \text{ mA}}$

Figure 3. Test Circuit for ON-Resistance

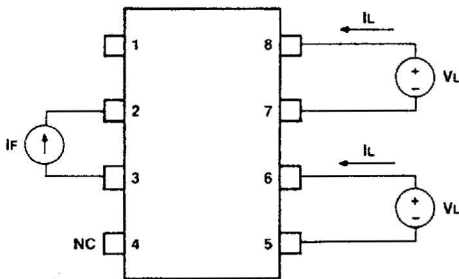

IF	VL	Measure	Parameter
0	±100 V	IL	Leakage = $ IL $
5.0 mA	±5 V	IL	Current Limit = $ IL $, $t = 10 \text{ ms}$

Figure 4. Test Circuit for Leakage and Current Limit

Test Circuits (continued)

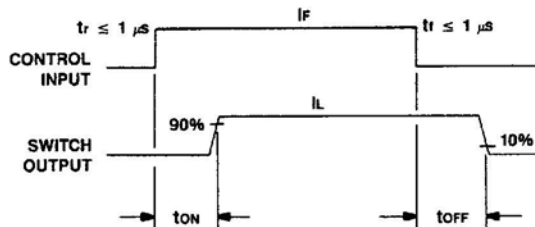
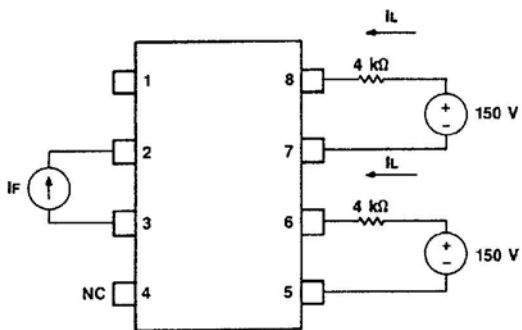

IF	VL	Measure	Parameter
5.0 mA	+150 V	IL	ton/toff = Δt IF to IL

Figure 5. ton/toff Test Circuits and Waveforms

Applications

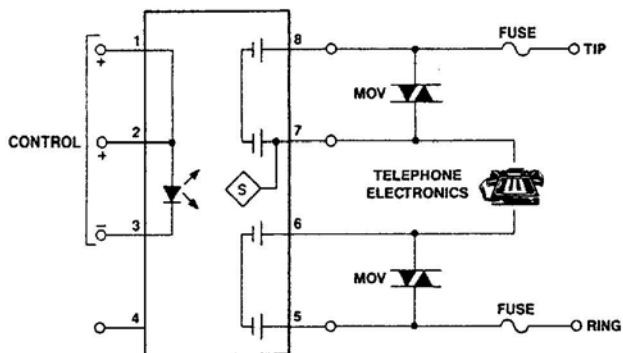

Figure 6. Balanced Switchhook Application

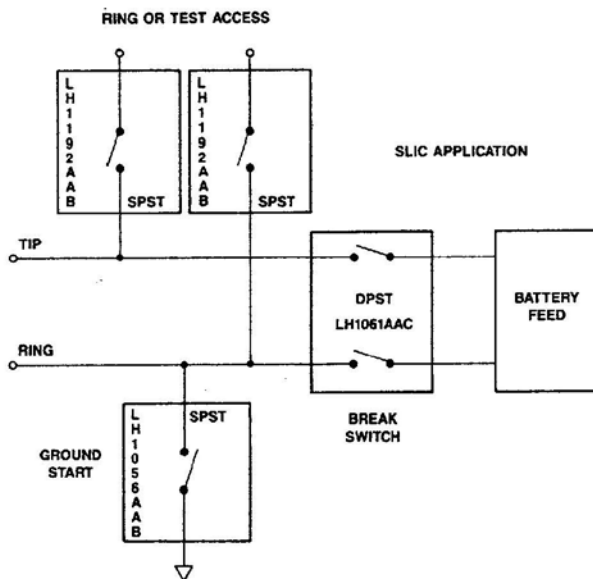

Figure 7. SLIC Application

LH1061AB/AAC High-Voltage, Solid-State Relay

Outline Drawings

8-Pin, Plastic DIP (LH1061AB)

Dimensions are in inches and (millimeters).

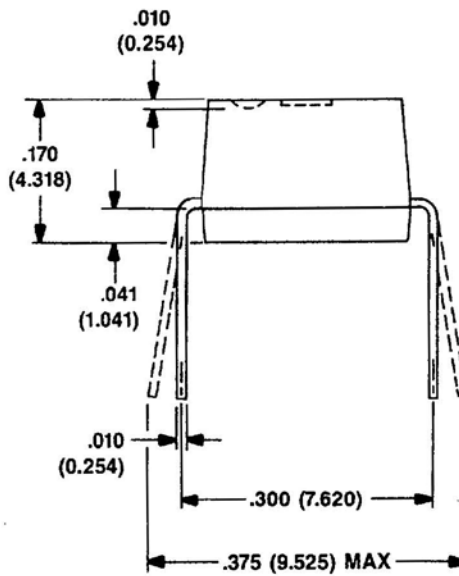
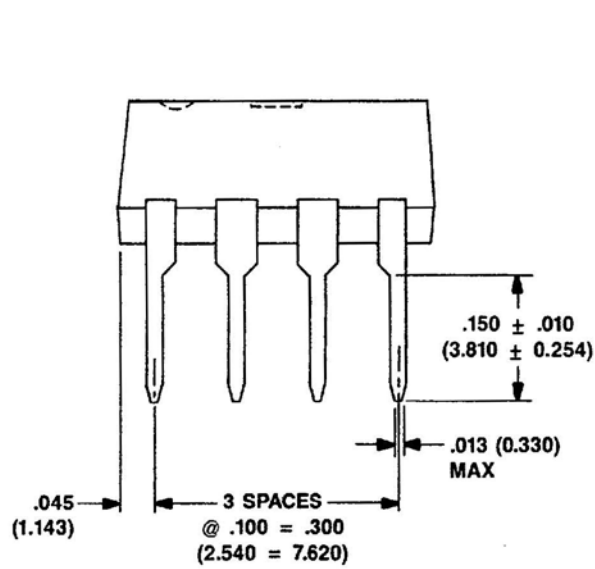
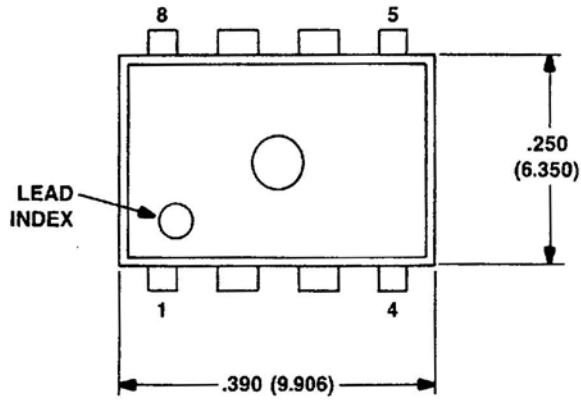

Outline Drawings (continued)

8-Pin, Plastic Gull-Wing (LH1061AAC)

Dimensions are in inches and (millimeters).

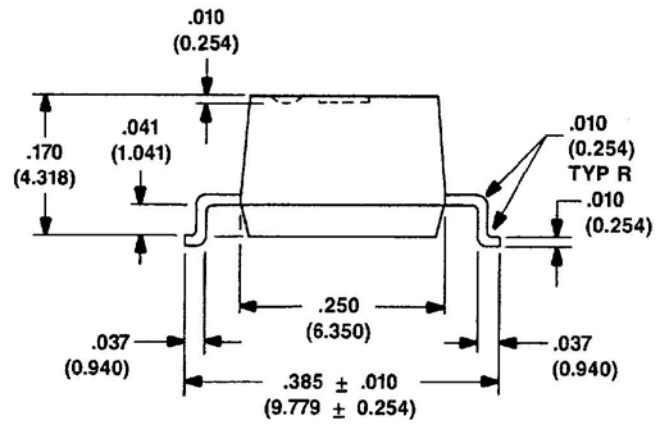
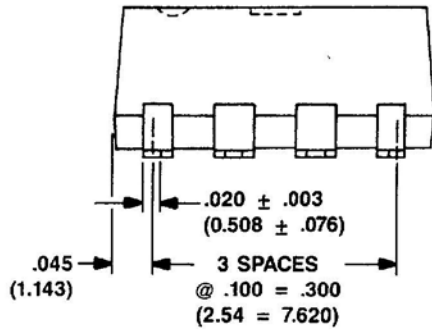
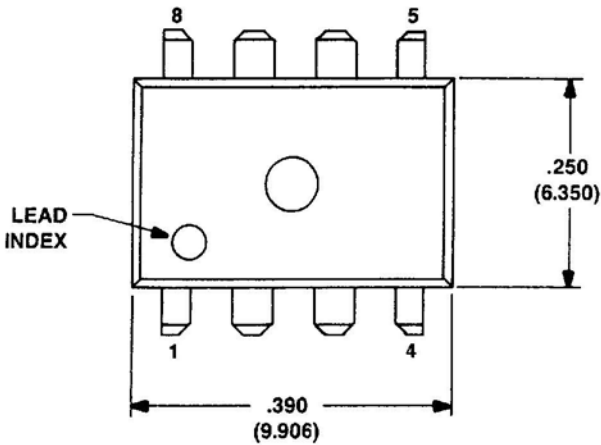

LH1061AB/AAC High-Voltage, Solid-State Relay

Ordering Information

Device	Package	Comcode
LH1061AB	8-Pin, Plastic DIP	104384482
LH1061AAC	8-Pin, Plastic Gull-Wing	104395504

Siemens North American Sales Offices

Serving the Northern U.S.

Westford, Massachusetts
(508) 692-0550

Livonia, Michigan
(313) 462-1195

Kokomo, Indiana
(317) 456-1928

Serving the Southern U.S.

Iselin, New Jersey
(908) 603-0600

Mt. Laurel, New Jersey
(609) 273-6677

Norcross, Georgia
(404) 449-3981

Dallas, Texas
(214) 733-4511

Serving the Western U.S.

Southern California
(714) 971-1274

North Central
(708) 884-7009

Northwest
(408) 777-4968

Rocky Mountains
(303) 451-5513

Serving Canada

Eastern Canada
(905) 819-8000

Western Canada
(514) 426-6103

Tel. (65) 778-8833

FAX (65) 777-7495

Telex RS 42898 ATTM

- AT&T Microelectronics
AT&T Japan Ltd.
31-11, Yoyogi 1-chome
Shibuya-ku, Tokyo 151
Japan

Tel. (03) 5371-2700

FAX (03) 5371-3556

- AT&T Microelectronica de España
Albacete, 5 - 2^a
28027 Madrid
Spain

Tel. (34) 1-404 6012

FAX (34) 1-404 3469

Telex 41494 AMESP

AT&T reserves the right to make changes to the product(s), software, or circuit(s) described herein without notice. No liability is assumed as a result of their use or application. No rights under any patent accompany the sale of any such product or circuit.

Copyright © 1990 AT&T

All Rights Reserved

Printed in U.S.A.

March 1990

DS90-040HVIC

This document replaces DS88-090LBC.

