

LH0080 Z80 CPU Central Processing Unit

Description

The LH0080 Z80 CPU (Z80 CPU for short below) is a general-purpose 8-bit microprocessor fabricated using an N-channel silicon-gate process.

The LH0080A Z80A, LH0080B Z80B, LH0080E Z80E CPU are the high speed version which can operate at the 4MHz, 6MHz and 8MHz system clock, respectively.

Features

1. 8-bit parallel processing microprocessor
2. N-channel silicon-gate process
3. 158 instructions (The instruction of the 8080A are included as a subset ; 8080A software compatibility is maintained)
4. 22 registers
5. The capability of 3 modes maskable interrupt and non-maskable interrupt
6. On-chip dynamic memory refresh counter
7. Instruction fetch cycle : 1.6 μ s (Z80), 1.0 μ s (Z80A), 0.67 μ s (Z80B), 0.5 μ s (Z80E)
8. Single +5V power supply and single phase clock
9. All inputs and outputs fully TTL compatible
10. 40-pin DIP (DIP40-P-600)
44-pin QFP (QFP44-P-1010A)
44-pin QFJ (QFJ44-P-S650)

Pin Connections

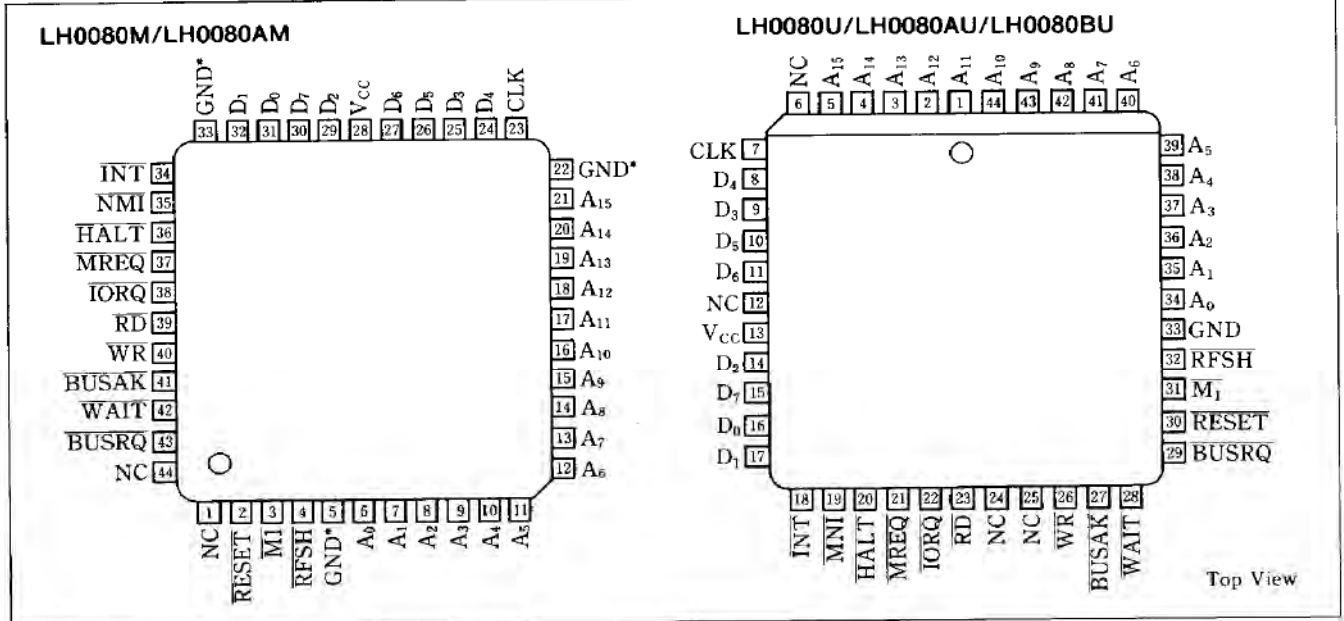
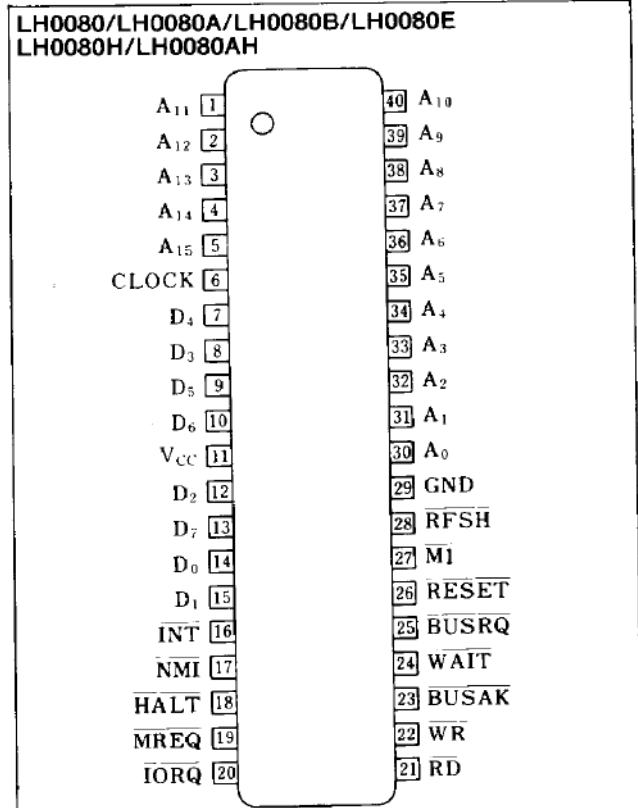

* The GND pins must be connected to the GND level.

■ Ordering Information

Product	Z80 CPU	Z80A CPU	Z80B CPU	Z80E CPU	Package	Operating temperature
Clock frequency	2.5MHz	4MHz	6MHz	8MHz		
Model No.	LH0080	LH0080A	LH0080B	LH0080E	40-pin DIP	0°C to +70°C
	LH0080H*	LH0080AH*				-20°C to +85°C
	LH0080M	LH0080AM			44-pin QFP	0°C to +60°C
	LH0080U	LH0080AU	LH0080BU		44-pin QFJ	0°C to +70°C

* H suffix is a wide temperature spec, packaged in 40-pin DIP.

■ Block Diagram

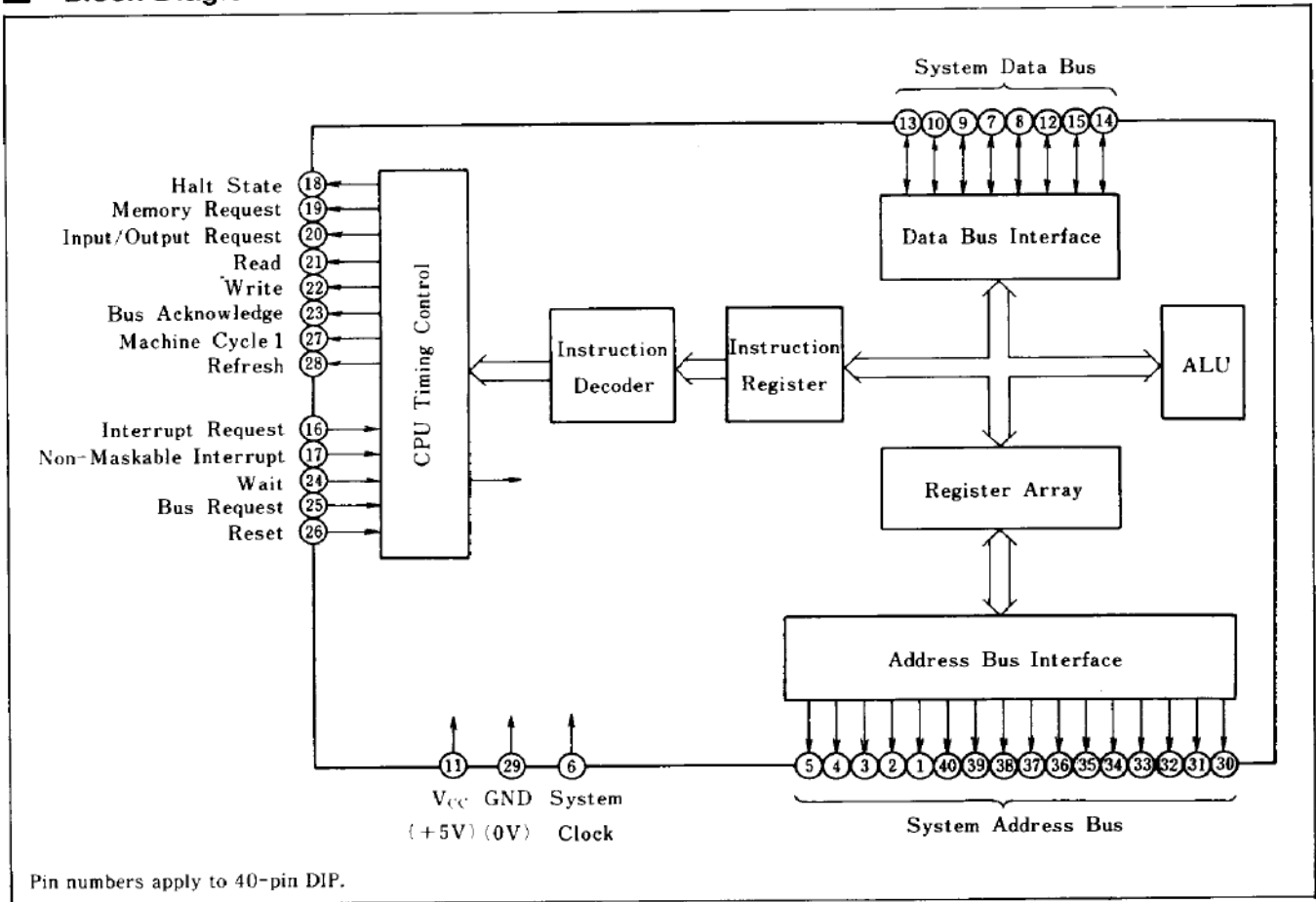

■ Pin Description

Signal	Pin name	I/O	Function
A ₀ -A ₁₅	Address bus	3-state O	System address bus
D ₀ -D ₇	Data bus	Bidirectional 3-state	System data bus
$\overline{\text{M1}}$	Machine cycle one	O	Active "Low". Indicates that the current machine cycle is the OP code fetch cycle of an instruction execution.
$\overline{\text{MREQ}}$	Memory request	3-state O	Active "Low". Indicates that the address bus holds a valid address for a memory read or memory write operation.
$\overline{\text{IORQ}}$	I/O request	3-state O	Active "Low". Indicates that the lower 8 bits of the address bus holds a valid I/O address for an I/O read or write operation. Also generated concurrently with $\overline{\text{M1}}$ during an interrupt acknowledge cycle to indicate an interrupt response.
$\overline{\text{RD}}$	Memory read	3-state O	Active "Low". Indicates that the CPU wants to read data from memory or an I/O device.
$\overline{\text{WR}}$	Memory write	3-state O	Active "Low". Indicates that the CPU data bus holds valid data to be stored at the addressed memory or I/O location.
$\overline{\text{RFSH}}$	Refresh	O	Active "Low". Indicates that the lower 7 bits of the system address bus can be used as a refresh address to the system's dynamic memories. Together with $\overline{\text{MREQ}}$ at "Low".
$\overline{\text{HALT}}$	Halt state	O	Active "Low". Indicates that a Halt instruction is being executed. While halted, the CPU executes NOPs to maintain memory refresh. The Halt state is cleared with $\overline{\text{RESET}}$, $\overline{\text{NMI}}$, or $\overline{\text{INT}}$ (when allowed).
$\overline{\text{WAIT}}$	Wait	I	Active "Low". Indicates to the CPU that the addressed memory or I/O devices are not ready for a data transfer. The CPU continues to enter a wait state as long as this signal is active.
$\overline{\text{INT}}$	Maskable interrupt request	I	Active "Low". Generated by I/O devices. The CPU honors a request at the end of the current instruction if the interrupt enable flip-flop is enabled.
$\overline{\text{NMI}}$	Non-maskable interrupt request	I	Active "Low". Has a higher priority than $\overline{\text{INT}}$. Always recognized at the end of the current instruction, independent of the status of the interrupt enable flip-flop. Automatically forces the Z80 CPU to restart at location 0066H.
$\overline{\text{RESET}}$	Reset	I	Active "Low". Resets the interrupt enable flip-flop, the program counter interrupt vector register and the memory refresh register, and sets the interrupt status to Mode 0, in order to initialize the CPU.
$\overline{\text{BUSRQ}}$	Bus request	I	Active "Low". Has a higher priority than $\overline{\text{NMI}}$. Always recognized at the end of the current machine cycle. Activated to allow a bus master other than the CPU to control the system bus.
$\overline{\text{BUSAK}}$	Bus acknowledge	O	Active "Low". Indicates to the requesting device that the external circuitry can control the system bus.
CLOCK	System clock	I	Inputs +5V single-phase clock.

Absolute Maximum Ratings

Parameter	Symbol	Ratings	Unit	Note
Input voltage	V_{IN}	-0.3 to +7.0	V	
Output voltage	V_{OUT}	-0.3 to +7.0	V	
Operating temperature	T_{opr}	0 to +70	°C	1
		0 to +60		2
		-20 to +85		3
Storage temperature	T_{stg}	-65 to +150	°C	

Note 1: 40-pin DIP and 44-pin QFJ

Note 2: 44-pin QFP

Note 3: 40-pin DIP with wide temperature spec.

Standard Test Conditions

The characteristics below apply for the following standard test conditions, unless otherwise noted. All voltages are referenced to GND (0V). Positive current flows into the referenced pin.

All ac parameters assume a load capacitance of 100 pF. Add 10 ns delay for each 50 pF increase in load up to a maximum of 200 pF for the data bus and 100 pF for address and control lines.

DC Characteristics

($V_{CC}=5V \pm 5\%$, $T_a=0$ to $+70^\circ\text{C}$ ^{Note 1})

Parameter	Symbol	Conditions	MIN.	TYP.	MAX.	Unit	
Clock input low voltage	V_{ILC}		-0.3		0.45	V	
Clock input high voltage	V_{IHC}		$V_{CC}-0.6$		$V_{CC}+0.3$	V	
Input low voltage	V_{IL}		-0.3		0.8	V	
Input high voltage	V_{IH}		2.0		V_{CC}	V	
Output low voltage	V_{OL}	$I_{OL}=1.8\text{mA}$			0.4	V	
Output high voltage	V_{OH}	$I_{OH}=-250\ \mu\text{A}$	2.4			V	
Current consumption	I_{CC}				150	mA	
					LH0080A	200	mA
					LH0080B	200	mA
					LH0080E	200	mA
Input leakage current	$ I_{LI} $	$0 \leq V_{IN} \leq V_{CC}$			10	μA	
3-state output leakage current in float	$ I_{LEAK} $	$V_{OUT}=0.4\text{V to }V_{CC}$			10	μA	

Note 1: $T_a=0$ to $+60^\circ\text{C}$ for 44-pin QFP

$T_a=-20$ to $+85^\circ\text{C}$ for 40-pin DIP with wide temperature spec.

Capacitance

($f=1\text{MHz}$, $T_a=25^\circ\text{C}$)

Parameter	Symbol	Conditions	MIN.	TYP.	MAX.	Unit
Clock capacitance	C_{CLOCK}	Unmeasured pins returned to ground			35	pF
Input capacitance	C_{IN}				5	pF
Output capacitance	C_{OUT}				10	pF

AC Characteristics

($V_{CC} = 5V \pm 5\%$, $T_a = 0$ to $+70^\circ\text{C}$ ^{Note 1})

No.	Parameter	Symbol	LH0080		LH0080A		LH0080B		LH0080E*		Unit
			MIN.	MAX.	MIN.	MAX.	MIN.	MAX.	MIN.	MAX.	
1	Clock cycle time	T_{cC}	400*		250*		165*		125*		ns
2	Clock pulse width (High)	T_{wCh}	180*		110*		65*		55*		ns
3	Clock pulse width (Low)	T_{wCl}	180	2000	110	2000	65	2000	55	2000	ns
4	Clock fall time	T_{fC}		30		30		20		10	ns
5	Clock rise time	T_{rC}		30		30		20		10	ns
6	Clock \uparrow to address valid delay	$T_{dCr} (A)$		145		110		90		80	ns
7	Address valid to MREQ \downarrow delay	$T_{dA} (MREQ\downarrow)$	125*		65*		35*		20*		ns
8	Clock \downarrow MREQ \downarrow delay	$T_{dCf} (MREQ\downarrow)$		100		85		70		60	ns
9	Clock \uparrow to MREQ \uparrow delay	$T_{dCr} (MREQ\uparrow)$		100		85		70		60	ns
10	MREQ pulse width (High)	T_{wMREQh}	170*		110*		65*		45*		ns
11	MREQ pulse width (Low)	T_{wMREQl}	360*		220*		135*		100*		ns
12	Clock \downarrow to MREQ \uparrow delay	$T_{dCf} (MREQ\uparrow)$		100		85		70		60	ns
13	Clock \downarrow to RD \downarrow delay	$T_{dCf} (RD\downarrow)$		130		95		80		70	ns
14	Clock \uparrow to RD \uparrow delay	$T_{dCr} (RD\uparrow)$		100		85		70		60	ns
15	Data setup time to clock \uparrow	$T_{sD} (Cr)$	50		35		30		30		ns
16	Data hold time from RD \uparrow	$T_{hD} (RD\uparrow)$	0		0		0		0		ns
17	WAIT setup time to clock \downarrow	$T_{sWAIT} (Cf)$	70		70		60		50		ns
18	WAIT hold time after clock \downarrow	$T_{hWAIT} (Cf)$	0		0		0		0		ns
19	Clock \uparrow to M1 \downarrow delay	$T_{dCr} (M1\downarrow)$		130		100		80		70	ns
20	Clock \uparrow to M1 \uparrow delay	$T_{dCr} (M1\uparrow)$		130		100		80		70	ns
21	Clock \uparrow to RFSH \downarrow delay	$T_{dCr} (RFSH\downarrow)$		180		130		110		95	ns
22	Clock \uparrow to RFSH \uparrow delay	$T_{dCr} (RFSH\uparrow)$		150		120		100		85	ns
23	Clock \downarrow to RD \uparrow delay	$T_{dCf} (RD\uparrow)$		110		85		70		60	ns
24	Clock \uparrow to RD \downarrow delay	$T_{dCr} (RD\downarrow)$		100		85		70		60	ns
25	Data Setup to clock \uparrow during M_2, M_3, M_4 or M_5 cycles	$T_{sD} (Cf)$	60		50		40		30		ns
26	Address stable prior to IORQ \downarrow	$T_{dA} (IORQ\downarrow)$	320*		180*		110*		75*		ns
27	Clock \uparrow IORQ \downarrow delay	$T_{dCr} (IORQ\downarrow)$		90		75		65		55	ns
28	Clock \downarrow to IORQ \uparrow delay	$T_{dCf} (IORQ\uparrow)$		110		85		70		60	ns
29	Data stable prior to WR \downarrow	$T_{dDm} (WR\downarrow)$	190*		80*		25*		5*		ns
30	Clock \downarrow WR \downarrow delay	$T_{dCf} (WR\downarrow)$		90		80		70		60	ns
31	WR pulse width	T_{wWR}	360*		220*		135*		100*		ns
32	Clock \downarrow to WR \uparrow delay	$T_{dCr} (WR\uparrow)$		100		80		70		60	ns
33	Data stable prior to WR \downarrow	$T_{dDi} (WR\downarrow)$	20*		-10*		-55*		-55*		ns
34	Clock \uparrow to WR \downarrow delay	$T_{dCr} (WR\downarrow)$		80		65		60		55	ns
35	Data stable from WR \uparrow	$T_{dWRr} (D)$	120*		60*		30*		15*		ns
36	Clock \downarrow to HALT \uparrow or \downarrow	$T_{dCf} (HALT)$		300		300		260		225	ns
37	NMI pulse width	T_{wNMI}	80		80		70		80		ns
38	BUSREQ setup time to clock \uparrow	$T_{sBUSRQ} (Cr)$	80		50		50		40		ns
39	BUSREQ hold time after clock \uparrow	$T_{hBUSRQ} (Cr)$	0		0		0		0		ns
40	Clock \uparrow to BUSACK \downarrow delay	$T_{dCr} (BUSACK\downarrow)$		120		100		90		80	ns
41	Clock \downarrow to BUSACK \uparrow delay	$T_{dCf} (BUSACK\uparrow)$		110		100		90		80	ns
42	Clock \uparrow to data float delay	$T_{dCr} (Dz)$		90		90		80		70	ns
43	Clock \uparrow to control output float delay (MREQ, IORQ, RD, and WR)	$T_{dCr} (CTz)$		110		80		70		60	ns
44	Clock \uparrow to address float delay	$T_{dCr} (Az)$		110		90		80		70	ns
45	MREQ \uparrow , IORQ \uparrow , RD and WR \uparrow to address hold time	$T_{dCTr} (A)$	160*		80*		35*		20*		ns

\uparrow Rising edge, \downarrow Falling edge

Note 1: $T_a = 0$ to $+60^\circ\text{C}$ for 44-pin QFP.

$T_a = -20$ to $+85^\circ\text{C}$ for 40-pin DIP with wide temperature spec.

No.	Parameter	Symbol	LH0080		LH0080A		LH0080B		LH0080E*		Unit
			MIN.	MAX.	MIN.	MAX.	MIN.	MAX.	MIN.	MAX.	
46	RESET ↓ to clock ↑ setup time	TsRESET (Cr)	90		60		60		45		ns
47	RESET from clock! ↑ hold time	ThRESET (Cr)	0		0		0		0		ns
48	INT to clock ↑ setup time	TsINTf (Cr)	80		80		70		55		ns
49	INT from clock ↑ hold time	ThINTR (Cr)	0		0		0		0		ns
50	M1 ↓ to IORQ ↓ delay	TdM1f (IORQf)	920*		565*		365*		270*		ns
51	Clock ↓ to IORQ ↓ delay	TdCf (IORQf)		110		85		70		60	ns
52	Clock ↑ to IORQ ↑ delay	TdCf (IORQr)		100		85		70		60	ns
53	Clock ↓ to data valid delay	TdCf (D)		230		150		130		115	ns

All ac parameters assume a load capacitance of 100 pF. Add 10 μs delay for each 50 pF increase in load up to a maximum of 200 pF for the data bus and 100 pF for address and control lines.

*For clock periods other than the minimums shown in the table, calculate parameters using the following expressions.

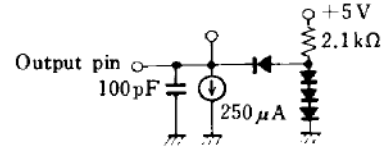

Footnotes to AC Characteristics

No.	Symbol	LH0080	LH0080A	LH0080B	LH0080E
1	TcC	TwCh + TwCl + TrC + TfC	TwCh + TwCl + TrC + TfC	TwCh + TwCl + TrC + TfC	TwCh + TwCl + TrC + TfC
2	TwCh	MAX. 200 μs	MAX. 200 μs	MAX. 200 μs	MAX. 200 μs
7	TdA (MREQf)	TwCh + TfC - 75	TwCh + TfC - 65	TwCh + TfC - 50	TwCh + TfC - 45
10	TwMREQh	TwCh + TfC - 30	TwCh + TfC - 20	TwCh + TfC - 20	TwCh + TfC - 20
11	TwMREQl	TcC - 40	TcC - 30	TcC - 30	TcC - 25
26	TdA (IORQf)	TcC - 80	TcC - 70	TcC - 55	TcC - 50
29	TdD (WRf)	TcC - 210	TcC - 170	TcC - 140	TcC - 120
31	TwWR	TcC - 40	TcC - 30	TcC - 30	TcC - 25
33	TdD (WRf)	TwCl + TrC - 180	TwCl + TrC - 140	TwCl + TrC - 140	TwCl + TrC - 120
35	TdWRr (D)	TwCl + TrC - 80	TwCl + TrC - 70	TwCl + TrC - 55	TwCl + TrC - 50
45	TdCTr (A)	TwCl + TrC - 40	TwCl + TrC - 50	TwCl + TrC - 50	TwCl + TrC - 45
50	TdM1f (IORQf)	2TcC + TwCh + TfC - 80	2TcC + TwCh + TfC - 65	2TcC + TwCh + TfC - 50	2TcC + TwCh + TfC - 45

AC Test Conditions :

V_{IH} = 2.0V V_{IHC} = V_{CC} - 0.6V V_{OH} = 2.0V FLOAT = ± 0.5
 V_{IL} = 0.8V V_{IIC} = 0.45V V_{OL} = 0.8V



■ CPU Timing

The Z80 CPU executes instructions by proceeding through a specific sequence of operations:

- Memory read or write
- I/O device read or write
- Interrupt acknowledge

The basic clock period is referred to as a T time or cycle, and three or more T cycles make up a machine cycle (M1, M2 or M3 for instance). Machine cycles can be extended either by the CPU automatically inserting one or more Wait states or by the insertion of one or more Wait states by the user.

(1) Instruction Opcode Fetch

The CPU places the contents of the Program Counter (PC) on the address bus at the start of the cycle (Fig. 1). Approximately one-half clock cycle later, $\overline{\text{MREQ}}$ goes active. When active, $\overline{\text{RD}}$ indicates that the memory data can be enabled onto the CPU data bus.

The CPU samples the $\overline{\text{WAIT}}$ input with the falling edge of clock state T_2 . During clock states T_3 and T_4 of an $\overline{\text{M1}}$ cycle dynamic RAM refresh can occur while the CPU starts decoding and executing the instruction. When the Refresh Control signal becomes active, refreshing of dynamic memory can take place.

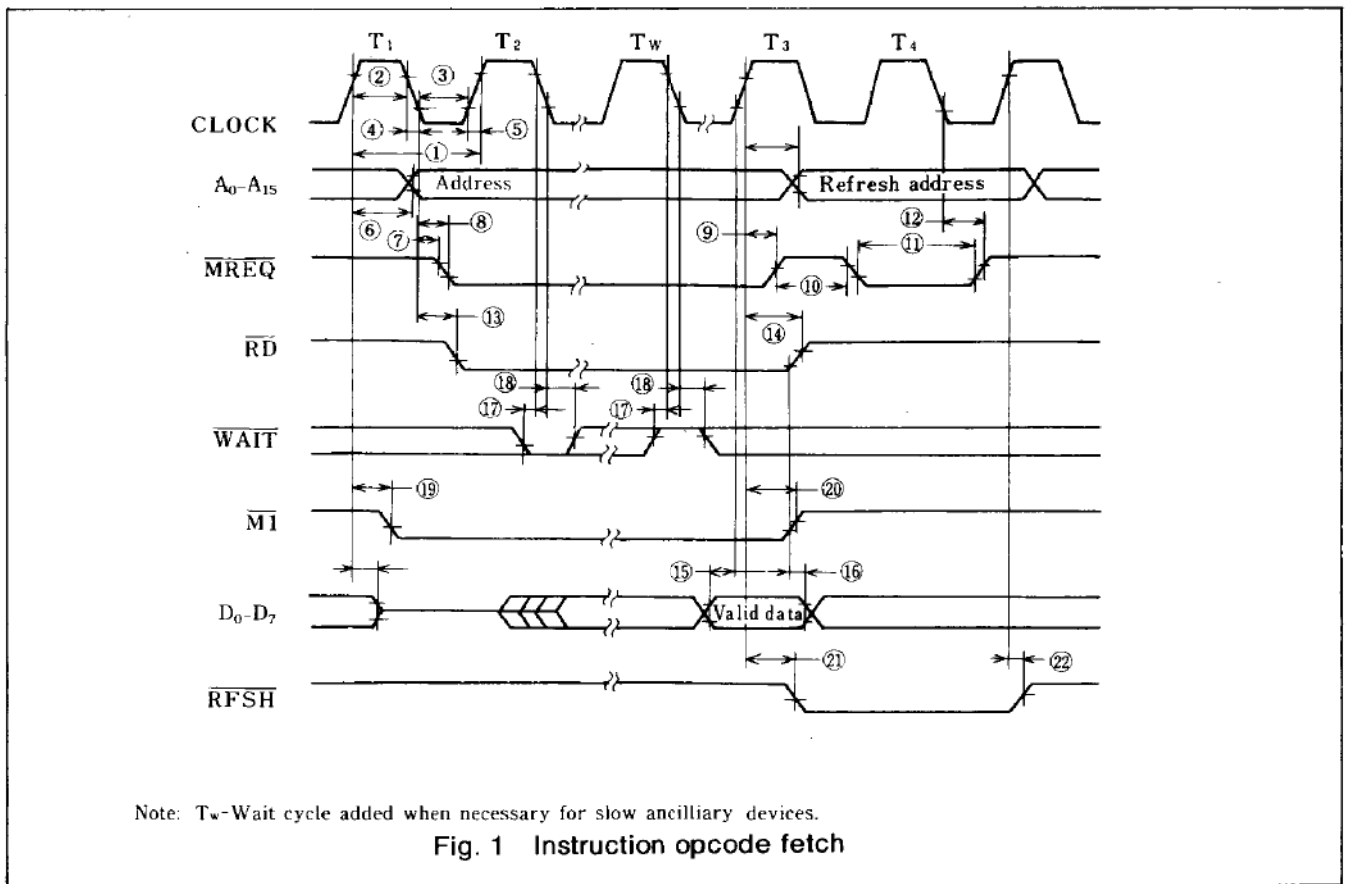

(2) Memory Read or Write Cycles

Fig. 2 shows the timing of memory read or write cycles other than an opcode fetch ($\overline{\text{M1}}$) cycle. The $\overline{\text{MREQ}}$ and $\overline{\text{RD}}$ signals function exactly as in the fetch cycle. In a memory write cycle, $\overline{\text{MREQ}}$ also becomes active when the address bus is stable. The $\overline{\text{WR}}$ line is active when the data bus is stable, so that it can be used directly as an R/W pulse to most semiconductor memories.

(3) Input or Output Cycles

Fig. 3 shows the timing for an I/O read or I/O write operation. During I/O operations, the CPU automatically inserts a single wait state (T_w). This extra wait state allows sufficient time for an I/O port to decode the address from the port address lines.

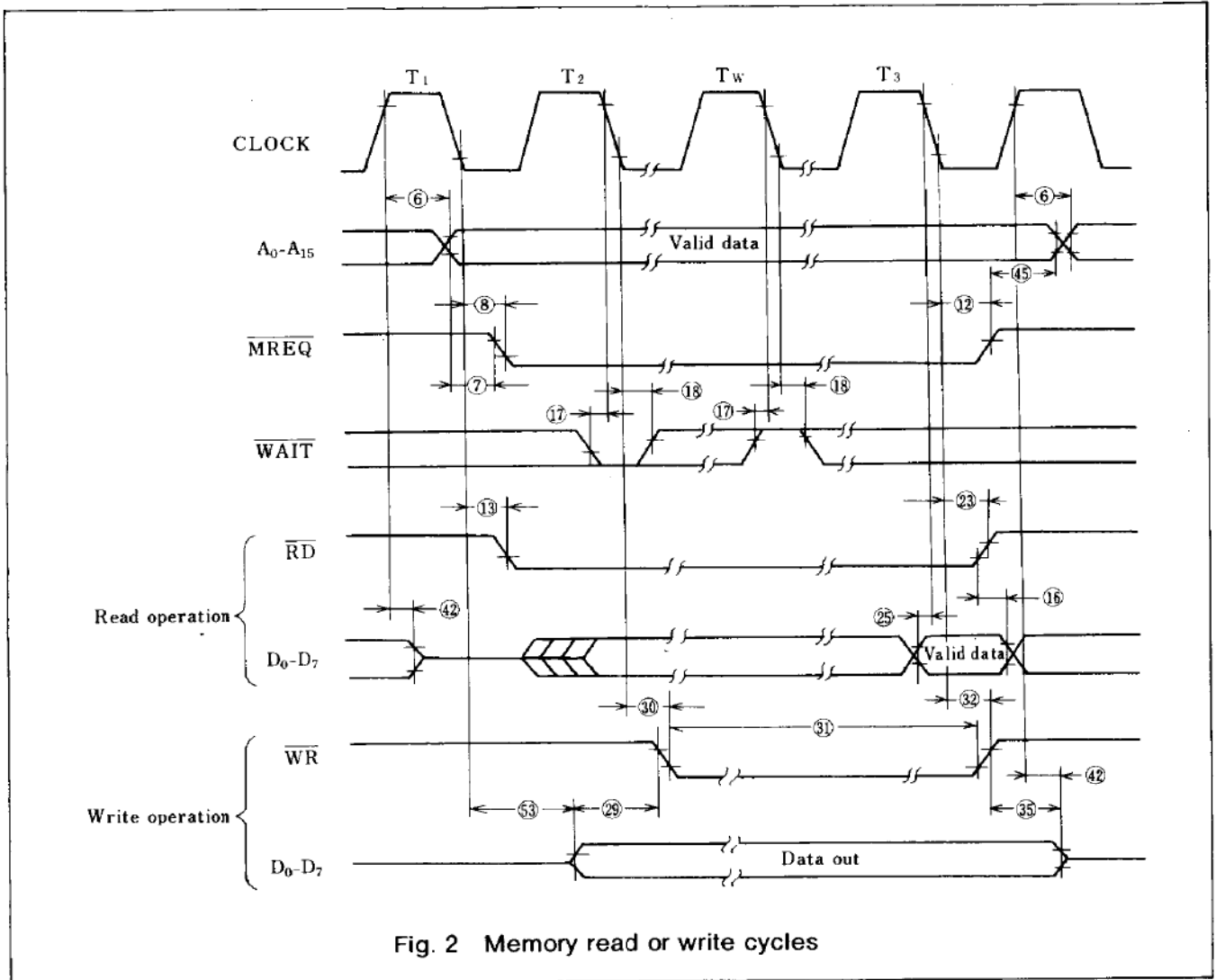
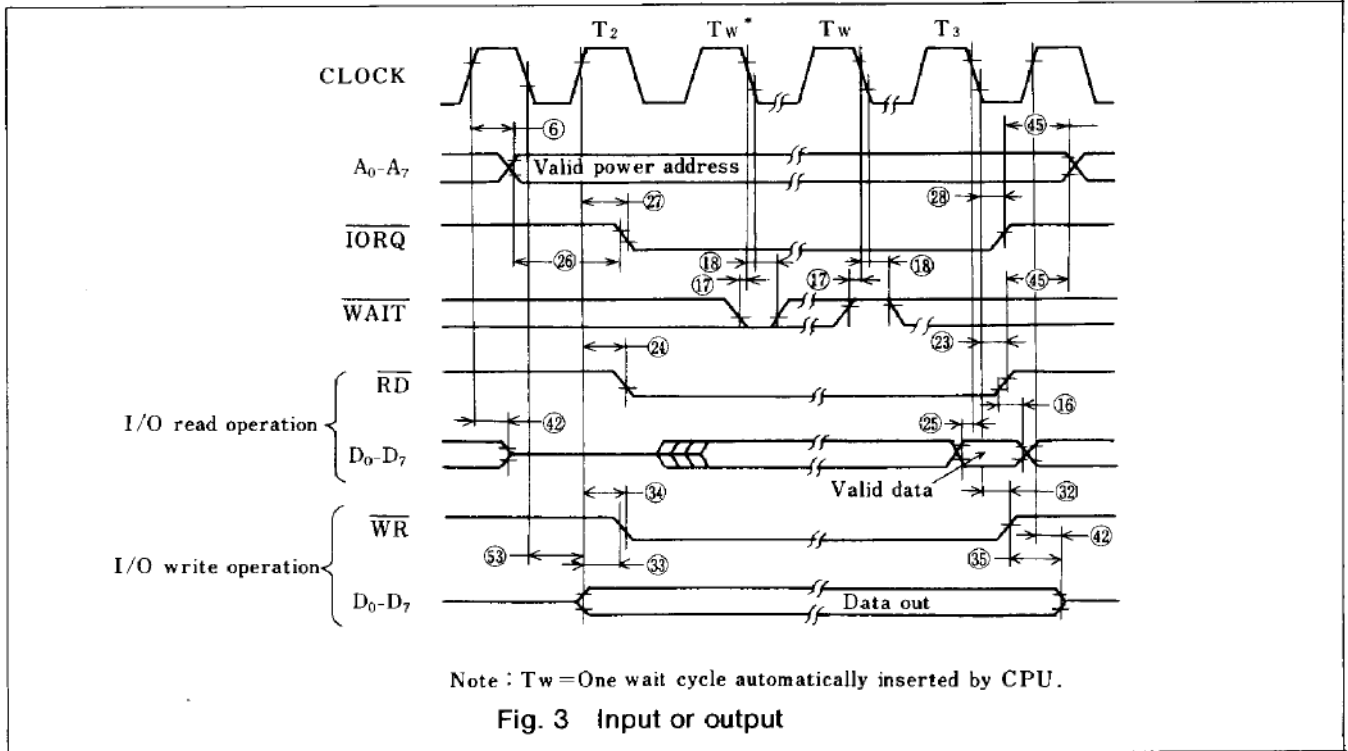

Fig. 2 Memory read or write cycles





(4) Interrupt request/acknowledge cycle

The CPU samples the interrupt signal with the rising edge of the last clock at the end of any instruction (Fig. 4). When an interrupt is accepted, a special M1 cycle is generated. During this M1 cycle,

IORQ becomes active (instead of MREQ) to indicate that the interrupting device can place an 8-bit vector on the data bus. The CPU automatically adds two wait states to this cycle.

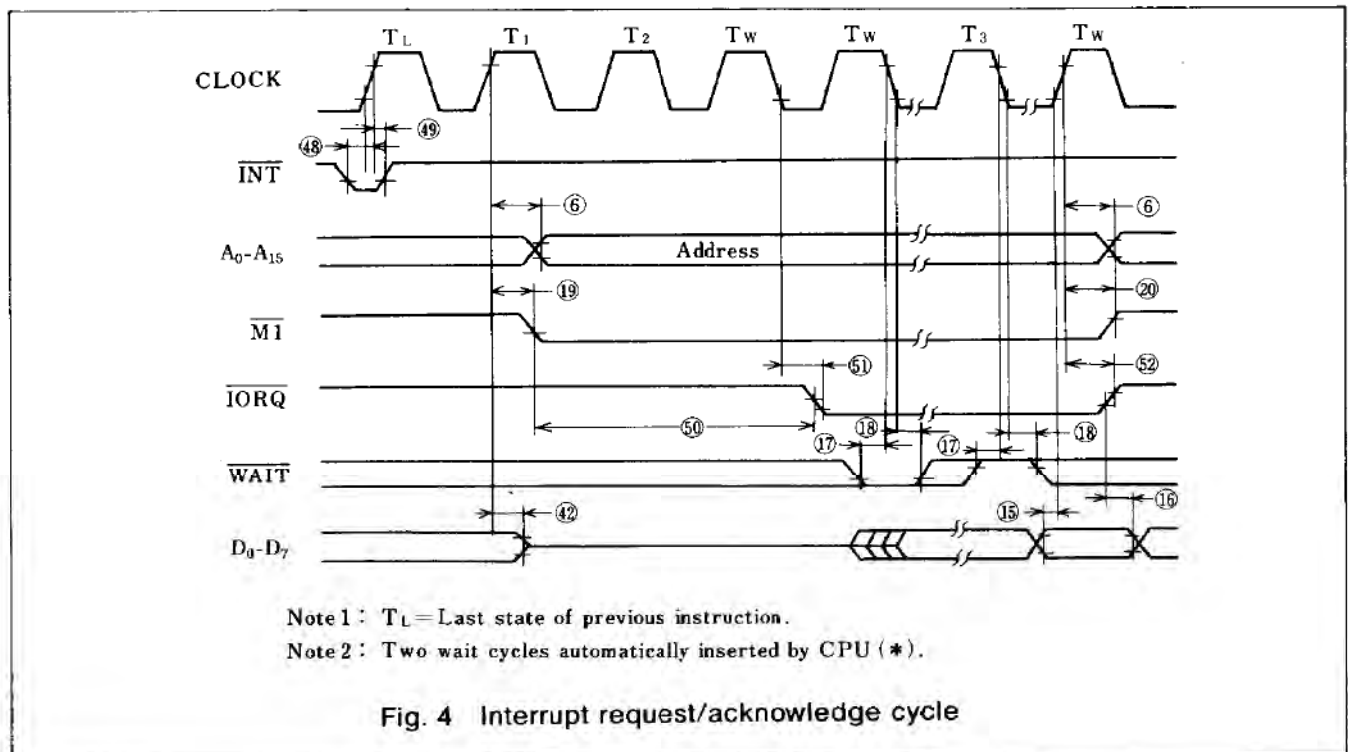

(5) Non-maskable interrupt request cycle

$\overline{\text{NMI}}$ is sampled at the same time as the maskable interrupt $\overline{\text{INT}}$ but has higher priority and cannot be disabled under software control.

The subsequent timing is similar to that of a nor-

mal instruction fetch except that data put on the bus by the memory is ignored. The CPU instead executes a restart (RST) operation and jumps to the NMI service routine located at address 0066H (Fig. 5).

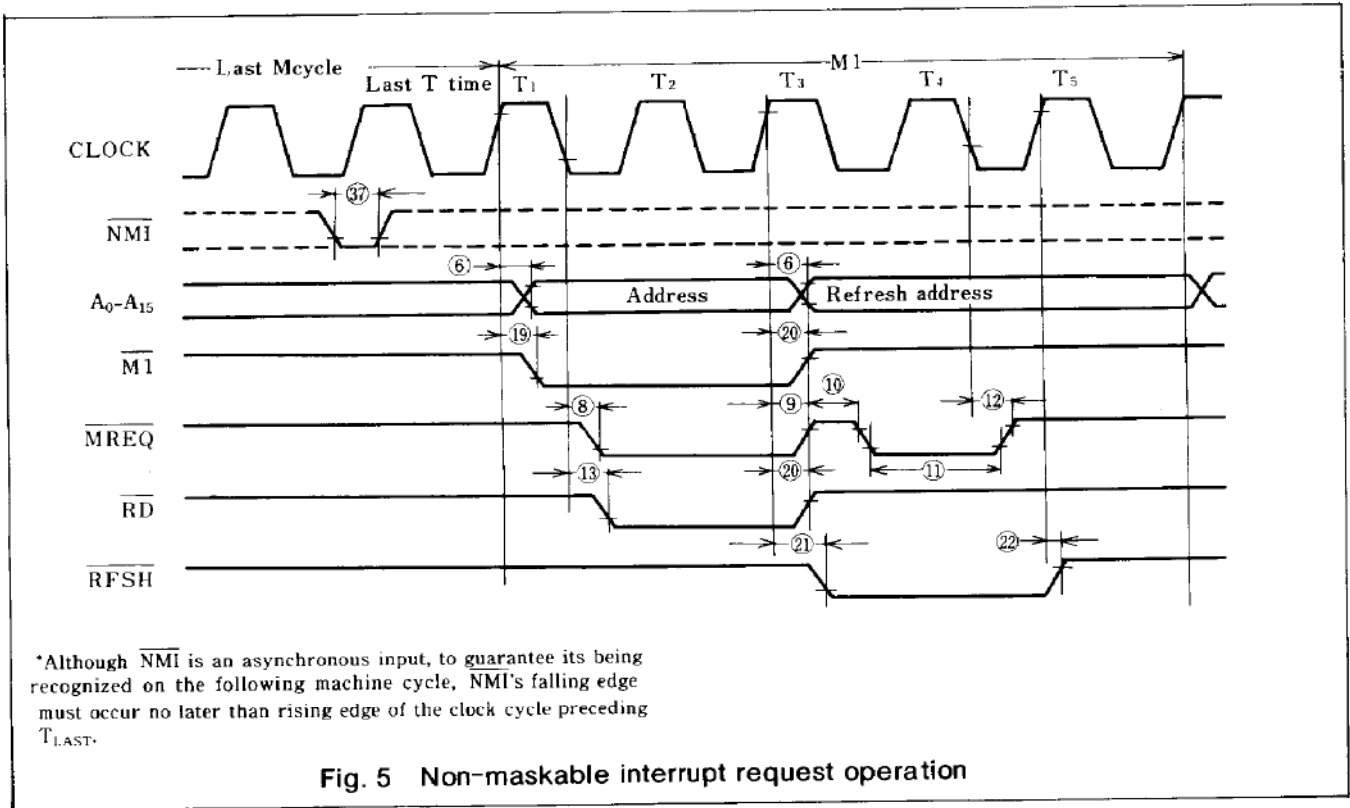

Fig. 5 Non-maskable interrupt request operation

(6) Bus request/acknowledge cycle

The CPU samples $\overline{\text{BUSREQ}}$ with the rising edge of the last clock period of any machine cycle (Fig. 6). If $\overline{\text{BUSREQ}}$ is active, the CPU sets its address, data, and $\overline{\text{MREQ}}$, $\overline{\text{IORQ}}$, $\overline{\text{RD}}$, and $\overline{\text{WR}}$ lines to a high-impedance state with the rising edge of the next clock pulse. At that time, any external device can take control of these lines, usually to transfer data between memory and I/O devices.

(7) Reset cycle

$\overline{\text{RESET}}$ must be active for at least three clock cycles for the CPU to properly accept it. As long as $\overline{\text{RESET}}$ remains active, the address and data buses float, and the control outputs are inactive. Once $\overline{\text{RESET}}$ goes inactive, three internal T cycles are consumed before the CPU resumes normal processing operation. $\overline{\text{RESET}}$ clears the PC register, so the first opcode fetch will be location 0000 (Fig. 8).

5

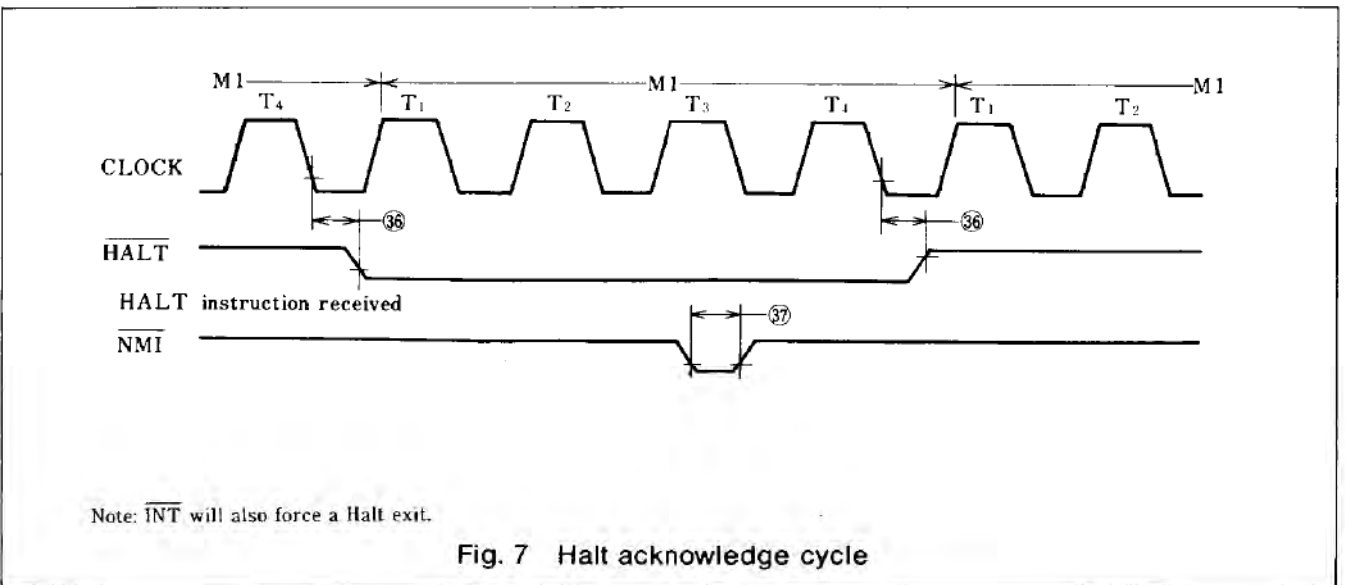
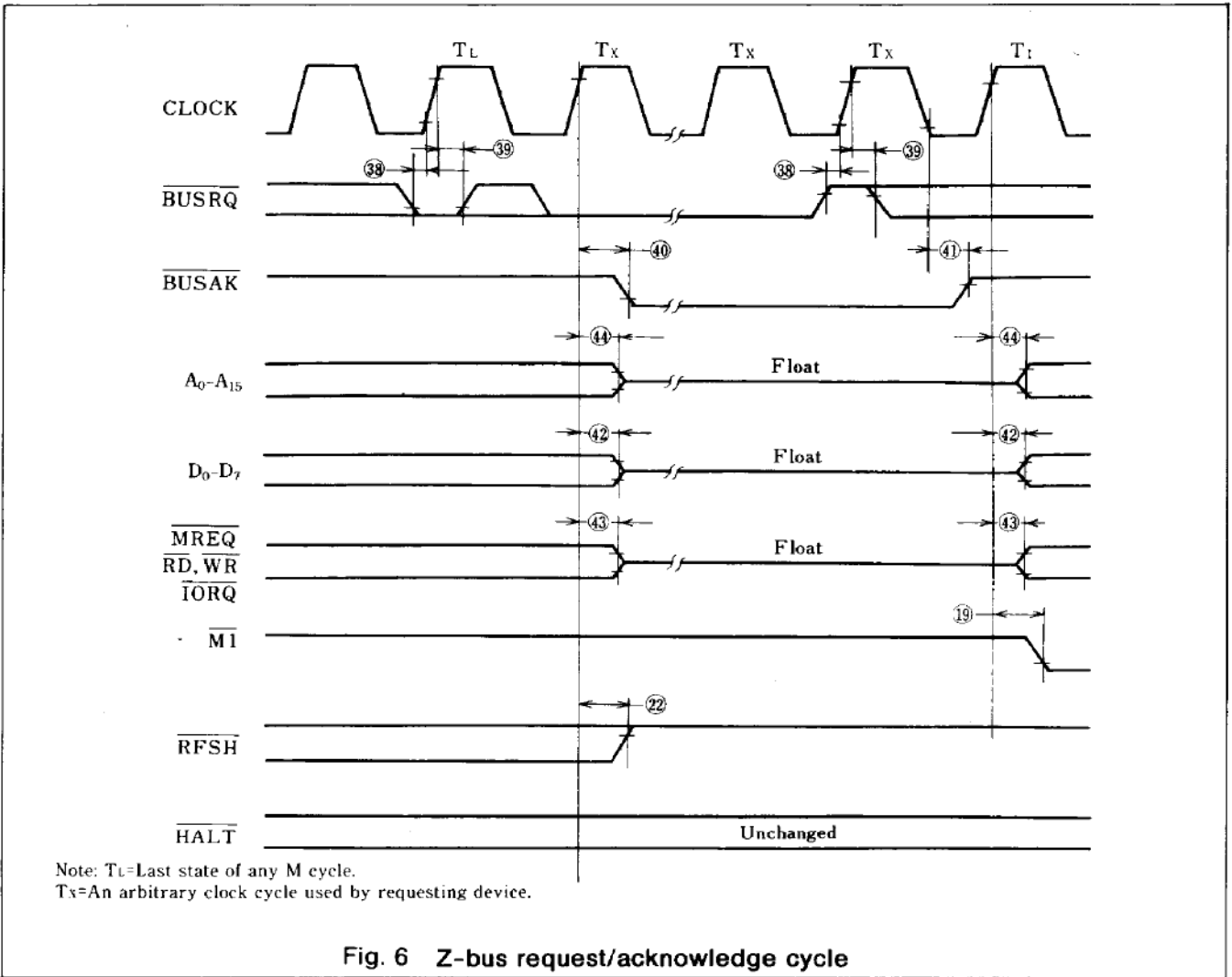

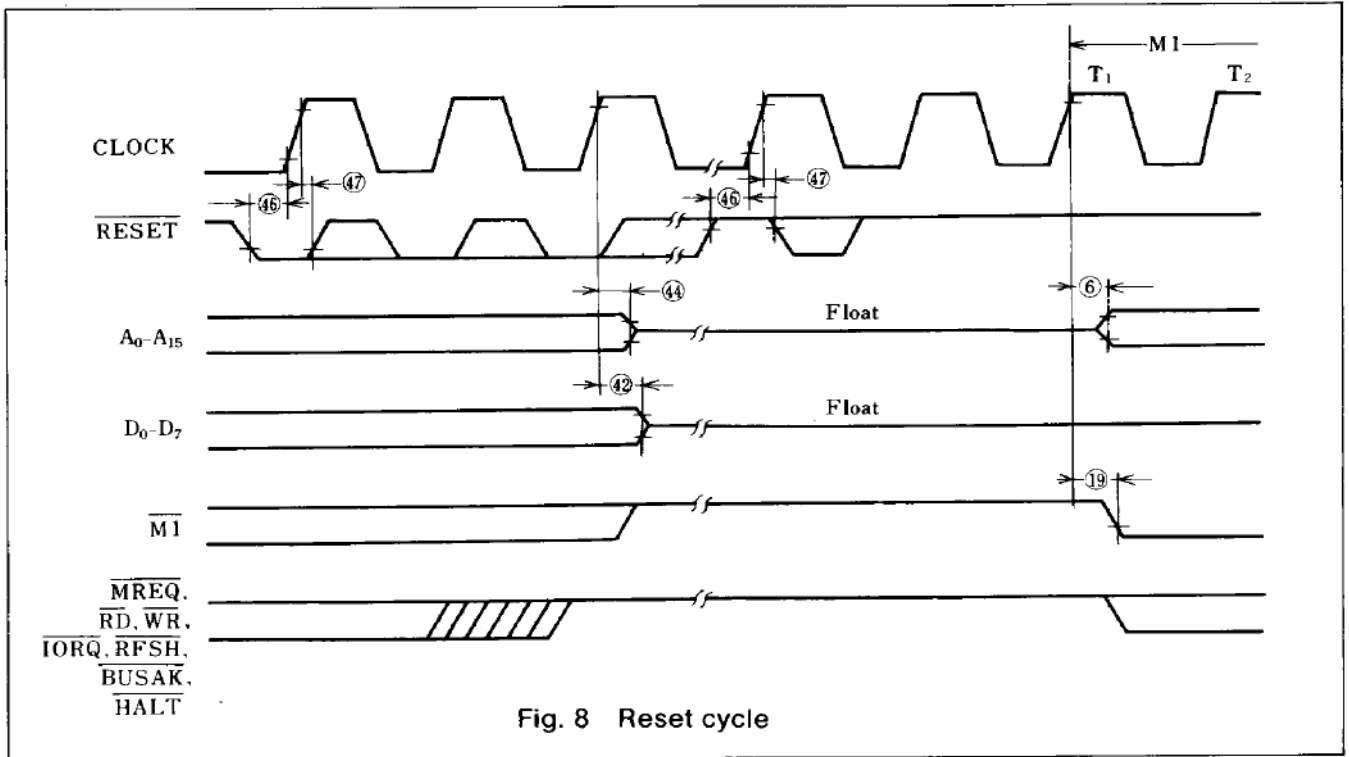

Fig. 8 Reset cycle

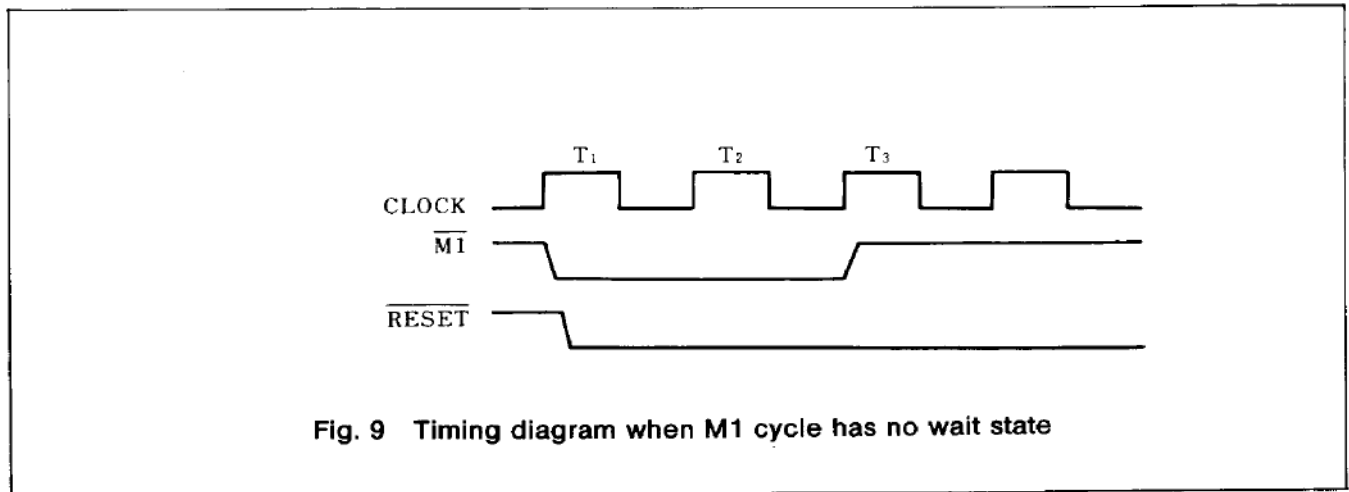

Fig. 9 Timing diagram when M1 cycle has no wait state

5

<Reference>

The RAM contents may be adversely affected by resetting the CPU while it is in operation.

To prevent this, a RESET signal should be input in the following timings.

(1) No wait state in the M1 cycle

Input a RESET signal to start sampling this signal at the clock rising in the M1 cycle's T₂ state.

(See Fig. 9.)

(2) A wait state in the M1 cycle

Input a RESET signal to start sampling this signal at the clock rising in the M1 cycle's T₃ state.

(See Fig. 10.)

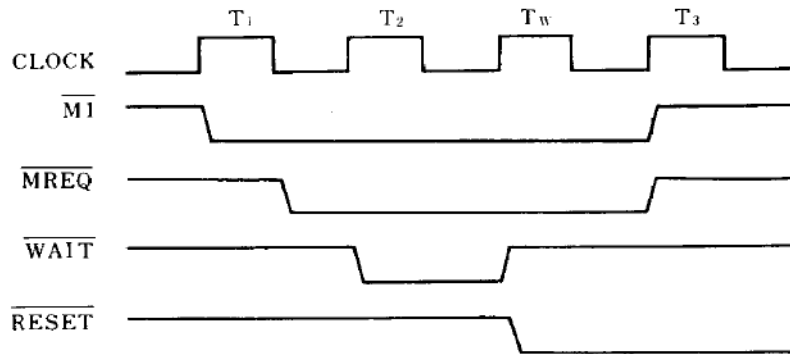
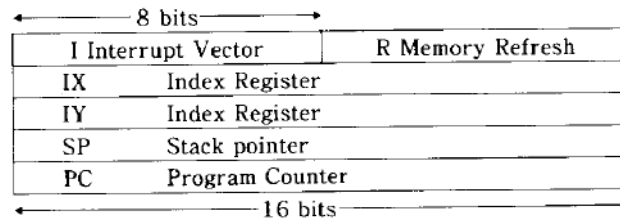

Fig. 10 Reset circuit and timing diagram when M1 cycle has a wait state

■ CPU Registers

A Accumulator	F Flag Register	A' Accumulator	F' Flag Register
B General Purpose	C General Purpose	B' General Purpose	C' General Purpose
D General Purpose	E General Purpose	D' General Purpose	E' General Purpose
H General Purpose	L General Purpose	H' General Purpose	L' General Purpose



■ Architecture

(1) CPU Registers

(i) **Program Counter (PC)** The program counter holds the 16 bits memory address of a current instruction. The CPU fetches the contents from memory address specified by the PC.

The PC feeds the data to the address line, automatically setting the PC value to +1. When a program jump takes place, a new value is directly set to the PC.

(ii) **Stack Pointer (SP)** The stack pointer holds the top 16-bit address of the stack with an external RAM. An external file is based on LIFO (Last-In, First-Out).

The data are transferred between a CPU-specified register and the stack by a PUSH or POP instruction. The last-pushed data are first popped from the stack.

(iii) **Index Register (IX & IY)** For index mode addressing, there are independent index registers IX and IY, each of which holds 16-bit reference address.

In the index mode, the index registers are used to designate the memory area for data input/output.

With an INDEX ADDRESSING instruction, an effective address comes by adding a one-byte displacement to the register content. This displacement is an integral signed two's complement number

(iv) **Interrupt Register (I)** The Z80 CPU has indirect subroutine call mode for any memory area according to an interrupt. For this purpose, this register stores the upper 8 bits of memory address for vectored interrupt processing and the lower 8 bits for the interrupting device.

(v) **Refresh Register (R)** The built-in refresh register provides user-transparent dynamic memory refresh. Its lower 7 bits are automatically incremented during each instruction fetch cycle.

While the CPU records a fetched instruction and executes the instruction, the refresh register data are placed on the address bus by a REFRESH control signal.

(vi) Accumulator and Flag Register (A & F)

The CPU has also two independent 8-bit accumulators in combination with two 8-bit flag registers.

The accumulators store an operand or the results of an 8-bit operation. The flag registers, on the other hand, deal with the results of an 8-bit or 16-bit operation; for example, seeing if the result is equal to 0 or not.

(vii) **General-Purpose Registers** There are several pairs of general-purpose registers. In each pair, they can be used separately or as a 16-bit paired register. The paired registers are BC, DE, HL, as well as BC' DE' HL'. Either of these sets can work by an "Exchange" instruction at any time on a program.

(2) Arithmetic/Logical Unit (ALU)

An 8-bit arithmetic/logical operation instruction is executed by the ALU inside the CPU. The ALU connects to each register through the internal bus for data transfer between them.

(3) Instruction Register, CPU Control

Each instruction is read out of the memory, held in the instruction register, and decoded. The con-

control unit controls this action and gives control signals necessary to read and write data from and to the registers.

The control unit also makes ALU control signal and other external control signals.

<Interrupts : General Operation> The Z80 CPU accepts two interrupt input signals: $\overline{\text{NMI}}$ and $\overline{\text{INT}}$. The $\overline{\text{NMI}}$ is a non-maskable interrupt and has the highest priority. $\overline{\text{INT}}$ is a lower priority interrupt and it requires that interrupts be enabled in software in order to operate.

(1) Non-Maskable Interrupt ($\overline{\text{NMI}}$)

The non-maskable interrupt will be accepted at all times by the CPU.

After recognition of the $\overline{\text{NMI}}$ signal, the CPU jumps to restart location 0066H.

(2) Maskable Interrupt ($\overline{\text{INT}}$)

The maskable interrupt, $\overline{\text{INT}}$, has three programmable response modes available.

(i) Mode 0 Interrupt Operation. This mode is similar to the 8080A microprocessor interrupt service procedures. The interrupting de-

vice places an instruction on the data bus. This is a Restart instruction or a Call instruction.

(ii) Mode 1 Interrupt Operation. Mode 1 operation is very similar to that for the $\overline{\text{NMI}}$. The principal difference is that the Mode 1 interrupt has a restart location of 0038H only.

(iii) Mode 2 Interrupt Operation. This interrupt mode has been designed to utilize most effectively the capabilities of the Z80 microprocessor and its associated peripheral family. The interrupting peripheral device selects the starting address (16 bits) of the interrupt service routine. It does this by placing an 8-bit vector on the data bus during the interrupt acknowledge cycle. The CPU forms a pointer using this byte as the lower 8-bits and the contents of the I register as the upper 8-bits. This points to an entry in a table of addresses for interrupt service routines. The CPU then jumps to the routine at that address.

All the Z80 peripheral devices have the interrupt priority circuit with a daisy-chain configuration. During an interrupt acknowledge cycle, vectors are automatically fed. For more details, refer to the Z80 PIO description.

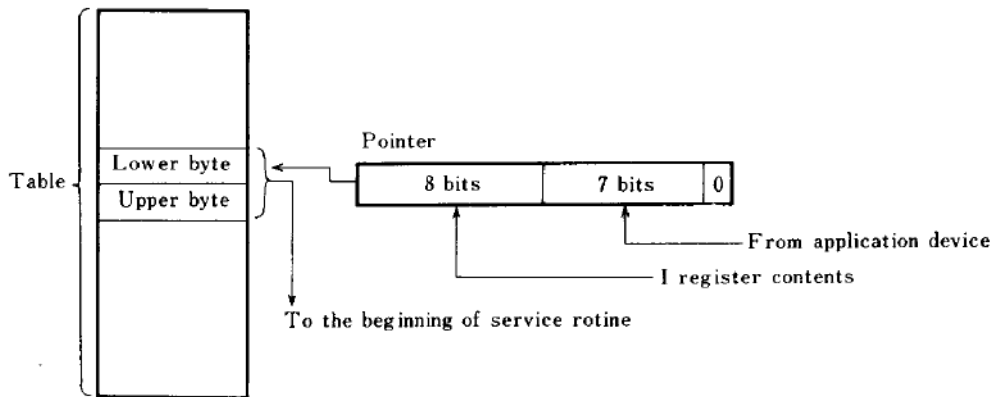

Fig. 1 Mode 2 interrupt diagram

■ Instruction Set

Table 1 8-bit load group

Mnemonic	Symbolic operation	OP code			HEX code (Basic)	Flags						No. of Bytes	No. of M Cycles	No. of T States	Comments
		76	543	210		C	Z	P/V	S	N	H				
LD r, r'	r ← r'	01	r	r'	40+	●	●	●	●	●	●	1	1	4	
LD r, n	r ← n	00	r	110 ← n →	06+	●	●	●	●	●	●	2	2	7	r,r Reg.
LD r, (HL)	r ← (HL)	01	r	110	46+	●	●	●	●	●	●	1	2	7	000 B
LD r, (IX+d)	r ← (IX+d)	11	011	101	DD	●	●	●	●	●	●	3	5	19	001 C
		01	r	110 ← d →	46+										
LD r, (IY+d)	r ← (IY+d)	11	111	101	FD	●	●	●	●	●	●	3	5	19	011 E
		01	r	110 ← d →	46										
LD (HL), r	(HL) ← r	01	110	r	70+	●	●	●	●	●	●	1	2	7	101 L
LD (IX+d), r	(IX+d) ← r	11	011	101	DD	●	●	●	●	●	●	3	5	19	111 A
		01	110	r ← d →	70+										
LD (IY+d), r	(IY+d) ← r	11	111	101	FD	●	●	●	●	●	●	3	5	19	
		01	110	r ← d →	70+										
LD (HL), n	(HL) ← n	00	110	110 ← n →	36	●	●	●	●	●	●	2	3	10	
LD (IX+d), n	(IX+d) ← n	11	011	101	DD	●	●	●	●	●	●	4	5	19	
		00	110	110 ← d → ← n →	36										
LD (IY+d), n	(IY+d) ← n	11	111	101	FD	●	●	●	●	●	●	4	5	19	
		00	110	110 ← d → ← n →	36										
LD A, (BC)	A ← (BC)	00	001	010	0A	●	●	●	●	●	●	1	2	7	
LD A, (DE)	A ← (DE)	00	011	010	1A	●	●	●	●	●	●	1	2	7	
LD A, (nn)	A ← (nn)	00	111	010	3A	●	●	●	●	●	●	3	4	13	
		← n → ← n →													
LD (BC), A	(BC) ← A	00	000	010	02	●	●	●	●	●	●	1	2	7	
LD (DE), A	(DE) ← A	00	010	010	12	●	●	●	●	●	●	1	2	7	
LD (nn), A	(nn) ← A	00	110	010	32	●	●	●	●	●	●	3	4	13	
		← n → ← n →													
LD A, I	A ← I	11	101	101	ED	●	↑	IFF	↑	0	0	2	2	9	
		01	010	111	57										
LD A, R	A ← R	11	101	101	ED	●	↑	IFF	↑	0	0	2	2	9	
		01	011	111	5F										
LD I, A	I ← A	11	101	101	ED	●	●	●	●	●	●	2	2	9	
		01	000	111	47										
LD R, A	R ← A	11	101	101	ED	●	●	●	●	●	●	2	2	9	
		01	001	111	4F										

Notes: r, r' means any of the registers A, B, C, D, E, H, L, IFF the content of the interrupt enable flip-flop, (IFF) is copied into the P/V flag.
 Flags: C (carry), Z (zero), S (sign), P/V (parity/overflow), H (half carry), N (add/subtract).
 ● = unchanged, 0 = reset, 1 = set, X = undefined.
 † = set or reset according to the result of the operation.



Table 2 16-bit load group

Mnemonic	Symbolic operation	OP code			HEX code (Basic)	Flags						No. of Bytes	No. of M Cycles	No. of T States	Comments
		76	543	210		C	Z	P/V	S	N	H				
LD dd, nn	dd ← nn	00	dd0	001	01+	●	●	●	●	●	●	3	3	10	dd Reg.
		←	n	→											
		←	n	→											
LD IX, nn	IX ← nn	11	011	101	DD	●	●	●	●	●	●	4	4	14	00 BC
		00	100	001	21										01 DE
		←	n	→											10 HL
		←	n	→											11 SP
LD IY, nn	IY ← nn	11	111	101	FD	●	●	●	●	●	●	4	4	14	
		00	100	001	21										
		←	n	→											
		←	n	→											
LD HL, (nn)	H ← (nn+1) L ← (nn)	00	101	010	2A	●	●	●	●	●	●	3	5	16	nn : 2-byte number. Lower byte just after opcode.
LD dd, (nn)	dd _H ← (nn+1) dd _L ← (nn)	11	101	101	ED	●	●	●	●	●	●	4	6	20	Upper byte comes next.
		01	dd1	011	4B+										
		←	n	→											
		←	n	→											
LD IX, (nn)	IX _H ← (nn+1) IX _L ← (nn)	11	011	101	DD	●	●	●	●	●	●	4	6	20	
		00	101	010	2A										
		←	n	→											
		←	n	→											
LD IY, (nn)	IY _H ← (nn+1) IY _L ← (nn)	11	111	101	FD	●	●	●	●	●	●	4	6	20	
		00	101	010	2A										
		←	n	→											
		←	n	→											
LD (nn), HL	(nn+1) ← H (nn) ← L	00	100	010	22	●	●	●	●	●	●	3	5	16	
LD (nn), dd	(nn+1) ← dd _H (nn) ← dd _L	11	101	101	ED	●	●	●	●	●	●	4	6	20	
		01	dd0	011	43+										
		←	n	→											
		←	n	→											
LD (nn), IX	(nn+1) ← IX _H (nn) ← IX _L	11	011	101	DD	●	●	●	●	●	●	4	6	20	
		00	100	010	22										
		←	n	→											
		←	n	→											
LD (nn), IY	(nn+1) ← IY _H (nn) ← IY _L	11	111	101	FD	●	●	●	●	●	●	4	6	20	
		00	100	010	22										
		←	n	→											
		←	n	→											
LD SP, HL	SP ← HL	11	111	001	F9	●	●	●	●	●	●	1	1	6	
LD SP, IX	SP ← IX	11	011	101	DD	●	●	●	●	●	●	2	2	10	
		11	111	001	F9										
LD SP, IY	SP ← IY	11	111	101	FD	●	●	●	●	●	●	2	2	10	
		11	111	001	F9										
PUSH qq	(SP-2) ← qq _L (SP-1) ← qq _H	11	qq0	101	C5+	●	●	●	●	●	●	1	3	11	qq Reg.
PUSH IX	(SP-2) ← IX _L (SP-1) ← IX _H	11	011	101	DD	●	●	●	●	●	●	2	4	15	00 BC
		11	100	101	E5										01 DE
PUSH IY	(SP-2) ← IY _L (SP-1) ← IY _H	11	111	101	FD	●	●	●	●	●	●	2	4	15	10 HL
		11	100	101	E5										11 AF
POP qq	qq _H ← (SP+1) qq _L ← (SP)	11	qq0	001	C1+	●	●	●	●	●	●	1	3	10	
POP IX	IX _H ← (SP+1) IX _L ← (SP)	11	011	101	DD	●	●	●	●	●	●	2	4	14	
		11	100	001	E1										
POP IY	IY _H ← (SP+1) IY _L ← (SP)	11	111	101	FD	●	●	●	●	●	●	2	4	14	
		11	100	001	E1										

Notes : dd is any of the register pairs BC, DE, HL, SP.

qq is any of the register pairs AF, BC, DE, HL.

(PAIR)_H, (PAIR)_L refer to high order and low order eight bits of the register pair respectively, e.g., BC_L=C, AF_H=A.

Flags : ● = unchanged, 0 = reset, 1 = set, X = undefined, † = set or reset according to the result of the operation

Table 3 Exchange, block transfer, block search groups

Mnemonic	Symbolic operation	OP code			HEX code (Basic)	Flags						No. of Bytes	No. of M Cycles	No. of T States	Comments
		76	543	210		C	Z	P/V	S	N	H				
EX DE, HL	DE ↔ HL	11	101	011	EB	●	●	●	●	●	●	1	1	4	
EX AF, AF'	AF ↔ AF'	00	001	000	08	●	●	●	●	●	●	1	1	4	
EXX	$\begin{pmatrix} BC \\ DE \\ HL \end{pmatrix} \leftrightarrow \begin{pmatrix} BC' \\ DE' \\ HL' \end{pmatrix}$	11	011	001	D9	●	●	●	●	●	●	1	1	4	Register bank and auxiliary register bank exchange
EX (SP), HL	H ↔ (SP+1) L ↔ (SP)	11	100	011	E3	●	●	●	●	●	●	1	5	19	
EX (SP), IX	IX _H ↔ (SP+1)	11	011	101	DD	●	●	●	●	●	●	2	6	23	
	IX _L ↔ (SP)	11	100	011	E3										
EX (SP), IY	IY _H ↔ (SP+1)	11	111	101	FD	●	●	●	●	●	●	2	6	23	
	IY _L ↔ (SP)	11	100	011	E3										
LDI	(DE) ← (HL)	11	101	101	ED	●	●	↓	●	0	0	2	4	16	Load (HL) into (DE), increment the pointers and decrement the byte counter (BC)
	DE ← DE+1	10	100	000	A0			①							
	HL ← HL+1														
	BC ← BC-1														
LDIR	(DE) ← (HL)	11	101	101	ED	●	●	0	●	0	0	2	5	21	If BC ≠ 0
	DE ← DE+1	10	110	000	B0										
	If BC=0 end														
LDD	(DE) ← (HL)	11	101	101	ED	●	●	↓	●	0	0	2	4	16	
	DE ← DE-1	10	101	000	A8			①							
	HL ← HL-1														
	BC ← BC-1														
LDDR	(DE) ← (HL)	11	101	101	ED	●	●	0	●	0	0	2	5	21	If BC ≠ 0
	DE ← DE-1	10	111	000	B8										
	If BC=0 end														
CPI	A - (HL)	11	101	101	ED	●	↓	↓	↓	1	↓	2	4	16	
	HL ← HL+1	10	100	001	A1		②	①							
	BC ← BC-1														
CPIR	A - (HL)	11	101	101	ED	●	↓	↓	↓	1	↓	2	5	21	If BC ≠ 0 and A ≠ (HL)
	HL ← HL+1	10	110	001	B1		②	①							
	If A = (HL) or BC=0 end														
CPD	A - (HL)	11	101	101	ED	●	↓	↓	↓	1	↓	2	4	16	
	HL ← HL-1	10	101	001	A9		②	①							
	BC ← BC-1														
CPDR	A - (HL)	11	101	101	ED	●	↓	↓	↓	1	↓	2	5	21	If BC ≠ 0 and A ≠ (HL)
	HL ← HL-1	10	111	001	B9		②	①							
	If A = (HL) or BC=0 end														

Note: ①P/V flag is 0 if the result of BC=0, otherwise P/V=1
 ②Z flag is 1 if A = (HL), otherwise Z=0

Flags: ● = unchanged
 0 = set, 1 = reset
 ↓ = set or reset according to the result of the operation

Table 4 8-bit arithmetic and logical group

Mnemonic	Symbolic operation	OP code			HEX code	Flags						No. of Bytes	No. of M Cycles	No. of T States	Comments	
		76	543	210	(Basic)	C	Z	P/V	S	N	H					
ADD A, r	$A \leftarrow A+r$	10	k	r	80+	†	†	V	†	0	†	1	1	4	r	Reg.
ADD A, n	$A \leftarrow A+n$	11	k	110	C6+	†	†	V	†	0	†	2	2	7		
ADD A, (HL)	$A \leftarrow A+(HL)$	10	k	110	86+	†	†	V	†	0	†	1	2	7	001	C
ADD A, (IX+d)	$A \leftarrow A+(IX+d)$	11	011	101	DD	†	†	V	†	0	†	3	5	19	010	D
		10	k	110	86+										011	E
		←	n	→											100	H
ADD A, (IY+d)	$A \leftarrow A+(IY+d)$	11	111	101	FD	†	†	V	†	0	†	3	5	19	101	L
		10	k	110	86+										111	A
		←	d	→											Mnemonic	k
ADC A, s	$A \leftarrow A+s+C$	4 types available based on the above ADD instruction (see Comments)				†	†	V	†	0	†	1*1	1*1	4*1	ADD	000
SUB s	$A \leftarrow A-s$					†	†	V	†	1	†				ADC	001
SBC A, s	$A \leftarrow A-s-C$					†	†	V	†	1	†				SUB	010
AND s	$A \leftarrow A \wedge s$					0	†	P	†	0	1				SBC	011
OR s	$A \leftarrow A \vee s$					0	†	P	†	0	0				AND	100
XOR s	$A \leftarrow A \oplus s$					0	†	P	†	0	0				OR	110
CP s	$A-s$					†	†	V	†	1	†				XOR	101
INC r	$r \leftarrow r+1$	00	r	ℓ	00+	●	†	V	†	0	†	1	1	4	CP	111
INC (HL)	$(HL) \leftarrow (HL)+1$	00	110	ℓ	30+	●	†	V	†	0	†	1	3	11	S=r, n, (HL), (IX+d), (IY+d)	
INC (IX+d)	$(IX+d) \leftarrow (IX+d)+1$	11	011	101	DD	●	†	V	†	0	†	3	6	23		
		00	110	ℓ	30+										Mnemonic	ℓ
		←	d	→											INC	100
INC (IY+d)	$(IY+d) \leftarrow (IY+d)+1$	11	111	101	FD	●	†	V	†	0	†	3	6	23	DEC	101
		00	110	ℓ	30+										m=r, (HL), (IX+d), (IY+d)	
		←	d	→												
DEC m	$m \leftarrow m-1$	4 types available based on the above INC instruction				●	†	V	†	1	†	1*2	1*2	4*2		
						1	3	11								
						3	6	23								
						3	6	23								

Note : V and P mean overflow and parity, respectively.
 Flags : ● = unchanged
 0 = reset
 1 = set
 X = undefined
 † = set or reset according to the result of the operation

*1: depends on s.
 *2: depends on m.

Table 5 General purpose arithmetic and CPU control groups

Mnemonic	Symbolic operation	OP code				Flags						No. of Bytes	No. of M Cycles	No. of T States	Comments
		76	543	210	(Basic)	C	Z	P/V	S	N	H				
DAA	Decimal adjustment (add/subtract)	00	100	111	27	↓	↓	P	↓	●	↓	1	1	4	Decimal adjust accumulator.
CPL	A ← A	00	101	111	2F	●	●	●	●	1	1	1	1	4	Complement accumulator (one's complement).
NEG	A ← 0 - A	11 101 101 01 000 100	ED 44	↓	↓	V	↓	1	↓	2	2	8	Negate acc. (two's complement).		
CCF	C ← C	00 111 111	3F	↓	●	●	●	0	X	1	1	4	Complement carry flag.		
SCF	C ← 1	00 110 111	37	1	●	●	●	0	0	1	1	4	Set carry flag.		
NOP	No operation	00 000 000	00	●	●	●	●	●	●	1	1	4			
HALT	CPU halted	01 110 110	76	●	●	●	●	●	●	1	1	4			
DI	IFF ← 0	11 110 011	F3	●	●	●	●	●	●	1	1	4	Interrupt not enable		
EI	IFF ← 1	11 111 011	FB	●	●	●	●	●	●	1	1	4	Interrupt enable		
IM 0	Set interrupt mode 0	11 101 101 01 000 110	ED 46	●	●	●	●	●	●	2	2	8	Set interrupt mode.		
IM 1	Set interrupt mode 1	11 101 101 01 010 110	ED 56	●	●	●	●	●	●	2	2	8			
IM 2	Set interrupt mode 2	11 101 101 01 011 110	ED 5E	●	●	●	●	●	●	2	2	8			

Note : IFF indicates the interrupt enable flip-flop, CY indicates the carry flip-flop.
 Flags : ● = unchanged, 0 = reset, 1 = set, X = undefined, ↓ = set or reset according to the result of the operation

Table 6 16-bit arithmetic group

Mnemonic	Symbolic operation	OP code				Flags						No. of Bytes	No. of M Cycles	No. of T States	Comments	
		76	543	210	(Basic)	C	Z	P/V	S	N	H					
ADD HL, ss	HL ← HL + ss	00	ss1	001	09+	↓	●	●	●	0	X	1	3	11	ss	Reg.
ADC HL, ss	HL ← HL + ss + C	11 101 101 01 ssl 010	ED 4A+	↓	↓	V	↓	0	X	2	4	15	00	BC		
SBC HL, ss	HL ← HL - ss - C	11 101 101 01 ss0 010	ED 42+	↓	↓	V	↓	1	X	2	4	15	10	HL		
ADD IX, pp	IX ← IX + pp	11 011 101 00 pp1 001	DD 09+	↓	●	●	●	0	X	2	4	15	pp	Reg.		
ADD IY, rr	IY ← IY + rr	11 111 101 00 rr1 001	FD 09+	↓	●	●	●	0	X	2	4	15	00	BC		
INC ss	ss ← ss + 1	00 ss0 011	03+	●	●	●	●	●	●	1	1	6	10	IX		
INC IX	IX ← IX + 1	11 011 101 00 100 011	DD 23	●	●	●	●	●	●	2	2	10	11	SP		
INC IY	IY ← IY + 1	11 111 101 00 100 011	FD 23	●	●	●	●	●	●	2	2	10	rr	Reg.		
DEC ss	ss ← ss - 1	00 ss1 011	0B+	●	●	●	●	●	●	1	1	6	00	BC		
DEC IX	IX ← IX - 1	11 011 101 00 101 011	DD 2B	●	●	●	●	●	●	2	2	10	01	DE		
DEC IY	IY ← IY - 1	11 111 101 00 101 011	FD 2B	●	●	●	●	●	●	2	2	10	10	IY		
													11	SP		

Note : ss is any of the register pairs BC, DE, HL, SP.
 pp is any of the register pairs BC, DE, IX, SP.
 rr is any of the register pairs BC, DE, IY, SP.
 Flags : ● = unchanged, 0 = reset, 1 = set, X = undefined, ↓ = set or reset according to the result of the operation



Table 7 Rotate and shift groups

Mnemonic	Symbolic operation	OP code				Flags					No. of Bytes	No. of M Cycles	No. of T States	Comments			
		76	543	210	(Basic)	C	Z	P/V	S	N					H		
RLCA		00	000	111	07	↑	●	●	●	0	0	1	1	4	Rotate left circular accumulator.		
RLA		00	010	111	17	↑	●	●	●	0	0	1	1	4	Rotate left accumulator.		
RRCA		00	001	111	0F	↑	●	●	●	0	0	1	1	4	Rotate right circular accumulator.		
RRA		00	011	111	1F	↑	●	●	●	0	0	1	1	4	Rotate right accumulator.		
RLCr		11	001	011	CB	↑	↑	P	↑	0	0	2	2	8	Rotate left circular register r.		
RLC (HL)		00	k	r	00+												
RLC (IX+d)		11	001	011	CB	↑	↑	P	↑	0	0	2	4	15	r	Reg.	
RLC (IY+d)		11	011	101	DD	↑	↑	P	↑	0	0	4	6	23	000	B	
		11	001	011	CB											001	C
		←	d	→												010	D
		00	k	110	06+											011	E
RLC (IY+d)		11	111	101	FD	↑	↑	P	↑	0	0	4	6	23	100	H	
		11	001	011	CB											101	L
		←	d	→												111	A
		00	k	110	06+												
RL m						↑	↑	P	↑	0	0				Mnemonic	k	
RRC m						↑	↑	P	↑	0	0				RLC	000	
RR m						↑	↑	P	↑	0	0	2*	2*	8*	RRC	001	
SLA m						↑	↑	P	↑	0	0	2	4	15	RL	010	
SRA m						↑	↑	P	↑	0	0	4	6	23	RR	011	
SRL m						↑	↑	P	↑	0	0	4	6	23	SLA	100	
															SRA	101	
															SRL	111	
RLD		11	101	101	ED	●	↑	P	↑	0	0	2	5	18	Rotate digit left and right between the accumulator and location (HL).		
		01	101	111	6F												
RRD		11	101	101	ED	●	↑	P	↑	0	0	2	5	18	The content of the upper half of the accumulator is unaffected.		
		01	100	111	67												

Flags : ● = unchanged
 0 = reset
 1 = set
 × = undefined
 ↑ = set or reset according to the result of the operation

Table 8 Bit set, reset and test group

Mnemonic	Symbolic operation	OP code		HEX code (Basic)	Flags						No. of Bytes	No. of M Cycles	No. of T States	Comments	
		76	543		210	C	Z	P/V	S	N				H	r
BIT b, r	$Z \leftarrow r_b$	11 001 011	CB		●	‡	X	X	0	1	2	2	8	r	Reg.
		01 b r	40+												
BIT b, (HL)	$Z \leftarrow (HL)_b$	11 001 011	CB		●	‡	X	X	0	1	2	3	12	000	B
		01 b 110	46+												
BIT b, (IX+d)	$Z \leftarrow (IX+d)_b$	11 011 101	DD		●	‡	X	X	0	1	4	5	20	010	D
		11 001 011	CB												
		$\leftarrow d \rightarrow$													
		01 b 110	46+												
BIT b, (IY+d)	$Z \leftarrow (IY+d)_b$	11 111 101	FD		●	‡	X	X	0	1	4	5	20	011	E
		11 001 011	CB												
		$\leftarrow d \rightarrow$													
		01 b 110	46+												
SET b, r	$r_b \leftarrow 1$	11 001 011	CB		●	●	●	●	●	●	2	2	8	100	H
		a b r													
SET b, (HL)	$(HL)_b \leftarrow 1$	11 001 011	CB		●	●	●	●	●	●	2	4	15	101	L
		a b 110	06+												
SET b, (IX+d)	$(IX+d)_b \leftarrow 1$	11 011 101	DD		●	●	●	●	●	●	4	6	23	110	A
		11 001 011	CB												
		$\leftarrow d \rightarrow$													
		a b 110	06+												
SET b, (IY+d)	$(IY+d)_b \leftarrow 1$	11 111 101	FD		●	●	●	●	●	●	4	6	23	111	7
		11 001 011	CB												
		$\leftarrow d \rightarrow$													
		a b 110	06+												
RES b, m	$m_b \leftarrow 0$										2*	2*	8*	m=r, (HL), (IX+d), (IY+d) *depends on m	
											2	4	15		
											4	6	23		
											4	6	23		

Note : The notation m_b indicates bit b (0 to 7) or location m.
 Flags : ● = unchanged
 0 = reset
 1 = set
 X = undefined
 ‡ = set or reset according to the result of the operation



Table 9 Jump group

Mnemonic	Symbolic operation	OP code			HEX code (Basic)	Flags					No. of Bytes	No. of M Cycles	No. of T States	Comments																		
		76	543	210		C	Z	P/V	S	N						H																
JP nn	PC ← nn	11 000 011	C3	●	●	●	●	●	●	3	3	10	<table border="1"> <thead> <tr> <th>cc</th> <th>Condition</th> </tr> </thead> <tbody> <tr><td>000</td><td>NZ</td></tr> <tr><td>001</td><td>Z</td></tr> <tr><td>010</td><td>NC</td></tr> <tr><td>011</td><td>C</td></tr> <tr><td>100</td><td>PO</td></tr> <tr><td>101</td><td>PE</td></tr> <tr><td>110</td><td>P</td></tr> <tr><td>111</td><td>M</td></tr> </tbody> </table>	cc	Condition	000	NZ	001	Z	010	NC	011	C	100	PO	101	PE	110	P	111	M	NZ : non-zero Z : zero C : carry PO : parity odd PE : parity even P : sign positive M : sign negative
		cc		Condition																												
		000		NZ																												
001	Z																															
010	NC																															
011	C																															
100	PO																															
101	PE																															
110	P																															
111	M																															
← n →																																
← n →																																
JP cc, nn	If condition cc is true PC ← nn, otherwise continue	11 cc 010	C2+	●	●	●	●	●	●	3	3	10																				
		← n →																														
		← n →									3	3	10																			
JR e	PC ← PC+e	00 011 000	18	●	●	●	●	●	●	2	3	12																				
		← e-2 →																														
JR C, e	If C=1 PC ← PC+e	00 111 000	38	●	●	●	●	●	●	2	3	12																				
	If C=0 continue	← e-2 →												2	2	7																
JR NC, e	If C=0 PC ← PC+e	00 110 000	30	●	●	●	●	●	●	2	3	12																				
	If C=1 continue	← e-2 →												2	2	7																
JR Z, e	If Z=1 PC ← PC+e	00 101 000	28	●	●	●	●	●	●	2	3	12																				
	If Z=0 continue	← e-2 →												2	2	7																
JR NZ, e	If Z=0 PC ← PC+e	00 100 000	20	●	●	●	●	●	●	2	3	12																				
	If Z=1 continue	← e-2 →												2	2	7																
JP (HL)	PC ← HL	11 101 001	E9	●	●	●	●	●	●	1	1	4																				
JP (IX)	PC ← IX	11 011 101	DD	●	●	●	●	●	●	2	2	8																				
		11 101 001	E9																													
JP (IY)	PC ← IY	11 111 101	FD	●	●	●	●	●	●	2	2	8																				
		11 101 001	E9																													
DJNZ, e	If B ← B-1 B ≠ 0 PC ← PC+1	00 010 000	10	●	●	●	●	●	●	2	3	13																				
	If B=0 continue	← e-2 →												2	2	8																

Note : e represents the extension in the relative addressing mode.
 e is a signed two's complement number in the range <-126, 129>
 e - 2 in the opcode provides an effective address of pc+e as PC is incremented by 2 prior to the addition of e.
 e itself is obtained from opcode position.

Flags : ● = unchanged
 0 = reset
 1 = set
 X = undefined
 † = set or reset according to the result of the operation

Table 10 Call and return group

Mnemonic	Symbolic operation	OP code				HEX code (Basic)	Flags					No. of Bytes	No. of M Cycles	No. of T States	Comments	
		76	54	32	10		C	Z	P/V	S	N					
CALL nn	(SP-1) ← PC _H	11	001	101	CD	●	●	●	●	●	●	3	5	17	cc	Condition
	(SP-2) ← PC _L	←	n	→												
	PC ← nn	←	n	→												
CALL cc, nn	If condition cc is false continue, otherwise same as CALL nn	11	cc	100	C4+	●	●	●	●	●	●	3	5	17	000	NZ
		←	n	→												
		←	n	→									3	3	10	001
RET	PC _L ← (SP) PC _H ← (SP+1)	11	001	001	C9	●	●	●	●	●	●	1	3	10	010	NC
RET cc	If condition cc is false continue, otherwise same as RET	11	cc	000	C0+	●	●	●	●	●	●	1	3	11	011	C
													1	1	5	100
RETI	Return from interrupt	11	101	101	ED	●	●	●	●	●	●	2	4	14	110	P
		01	001	101	4D											
RETN	Return from non-maskable interrupt	11	101	101	ED	●	●	●	●	●	●	2	4	14	111	M
		01	000	101	45											
RST p	(SP-1) ← PC _H (SP-2) ← PC _L PC _H ← 0 PC _L ← p	11	t	111	C7+	●	●	●	●	●	●	1	3	11	101	PE

Flags : ● = unchanged
 0 = reset
 1 = set
 X = undefined
 † = set or reset according to the result of the operation



Table 11 Input and output group

Mnemonic	Symbolic operation	OP code			HEX code (Basic)	Flags					No. of Bytes	No. of M Cycles	No. of T States	Comments	
		76	543	210		C	Z	P/V	S	N					H
IN A, (n)	A ← (n)	11 011 011			DB	●	●	●	●	●	●	2	3	11	n → A ₀ -A ₇ Acc → A ₈ -A ₁₅
IN r, (C)	r ← (C)	11 101 101 ← n →			ED 40+	●	↓	P	↓	0	↓	2	3	12	
INI	(HL) ← (C) B ← B-1 HL ← HL+1	11 101 101 10 100 010			ED A2	X	↓ ①	X	X	1	X	2	4	16	C → A ₀ -A ₇ B → A ₈ -A ₁₅
INIR	(HL) ← (C) B ← B-1 HL ← HL+1 Repeat until B=0	11 101 101			ED	X	1	X	X	1	X	2	5 (If B≠0)	21	r Reg. 000 B 001 C 010 D 011 E 100 H 101 L 111 A
		10 110 010			B2		②					2	4 (If B=0)	16	
IND	(HL) ← (C) B ← B-1 HL ← HL-1	11 101 101 10 101 010			ED AA	X	↓ ①	X	X	1	X	2	4	16	
INDR	(HL) ← (C) B ← B-1 HL ← HL-1 Repeat until B=0	11 101 101			ED	X	1	X	X	1	X	2	5 (If B≠0)	21	
		10 111 010			BA		②					2	4 (If B=0)	16	
OUT (n), A	(n) ← A	11 010 011 ← n →			D3	●	●	●	●	●	●	2	3	11	n → (A-BUS) ₀₋₇ Acc → (A-BUS) ₈₋₁₅
OUT (C), r	(C) ← r	11 101 101 01 r 001			ED 41+	●	●	●	●	●	●	2	3	12	
OUTI	(C) ← (HL) B ← B-1 HL ← HL+1	11 101 101 10 100 011			ED A3	X	↓ ①	X	X	1	X	2	4	16	C → A ₀ -A ₇
OTIR	(C) ← (HL) B ← B-1 HL ← HL+1 Repeat until B=0	11 101 101			ED	X	1	X	X	1	X	2	5 (If B≠0)	21	B → A ₈ -A ₁₅
		10 110 011			B3		②					2	4 (If B=0)	16	
OUTD	(C) ← (HL) B ← B-1 HL ← HL-1	11 101 101 10 101 011			ED AB	X	↓ ①	X	X	1	X	2	4	16	
OTDR	(C) ← (HL) B ← B-1 HL ← HL-1 Repeat until B=0	11 101 101			ED	X	1	X	X	1	X	2	5 (If B≠0)	21	
		10 111 011			BB		②					2	4 (If B=0)	16	

Note : ① If the result of B-1 is zero the Z flag is set, otherwise it is reset.

② Z flag is set upon instruction completion only.

Flags : ● = unchanged

0 = reset

1 = set

X = undefined

↓ = set or reset according to the result of the operation