

FEATURES

- Single Supply Operation
 - Input Voltage Range Extends to Ground
 - Output Swings to Ground while Sinking Current
- Pin Compatible to 1458 and 324 with Precision Specs
- *Guaranteed* Offset Voltage 150 μ V Max.
- *Guaranteed* Low Drift 2 μ V/ $^{\circ}$ C Max.
- *Guaranteed* Offset Current 0.8nA Max.
- *Guaranteed* High Gain
 - 5mA Load Current 1.5 Million Min.
 - 17mA Load Current 0.8 Million Min.
- *Guaranteed* Low Supply Current 500 μ A Max.
- Low Voltage Noise, 0.1Hz to 10Hz 0.55 μ Vp-p
- Low Current Noise—Better than OP-07, 0.07pA/ \sqrt Hz

APPLICATIONS

- Battery-Powered Precision Instrumentation
 - Strain Gauge Signal Conditioners
 - Thermocouple Amplifiers
 - Instrumentation Amplifiers
- 4mA–20mA Current Loop Transmitters
- Multiple Limit Threshold Detection
- Active Filters
- Multiple Gain Blocks

LT, LTC and LT are registered trademarks of Linear Technology Corporation.

DESCRIPTION

The LT[®]1014 is the first precision quad operational amplifier which directly upgrades designs in the industry standard 14-pin DIP LM324/LM348/OP-11/4156 pin configuration. It is no longer necessary to compromise specifications, while saving board space and cost, as compared to single operational amplifiers.

The LT1014's low offset voltage of 50 μ V, drift of 0.3 μ V/ $^{\circ}$ C, offset current of 0.15nA, gain of 8 million, common-mode rejection of 117dB and power supply rejection of 120dB qualify it as four truly precision operational amplifiers. Particularly important is the low offset voltage, since no offset null terminals are provided in the quad configuration. Although supply current is only 350 μ A per amplifier, a new output stage design sources and sinks in excess of 20mA of load current, while retaining high voltage gain.

Similarly, the LT1013 is the first precision dual op amp in the 8-pin industry standard configuration, upgrading the performance of such popular devices as the MC1458/1558, LM158 and OP-221. The LT1013's specifications are similar to (even somewhat better than) the LT1014's.

Both the LT1013 and LT1014 can be operated off a single 5V power supply: input common-mode range includes ground; the output can also swing to within a few millivolts of ground. Crossover distortion, so apparent on previous single-supply designs, is eliminated. A full set of specifications is provided with \pm 15V and single 5V supplies.

3 Channel Thermocouple Thermometer

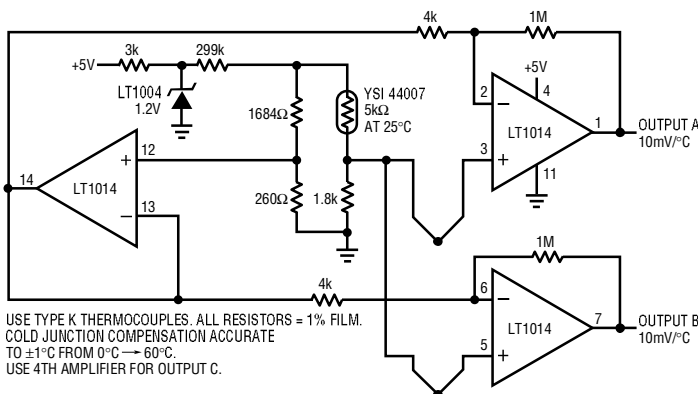

LT1014 Distribution of Offset Voltage

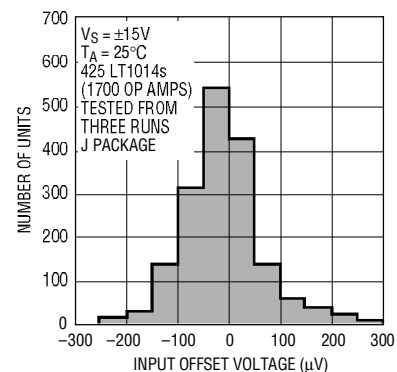

LT1013/LT1014

ABSOLUTE MAXIMUM RATINGS

Supply Voltage $\pm 22\text{V}$
 Differential Input Voltage $\pm 30\text{V}$
 Input Voltage Equal to Positive Supply Voltage
 5V Below Negative Supply Voltage
 Output Short-Circuit Duration Indefinite
 Storage Temperature Range
 All Grades -65°C to 150°C

Lead Temperature (Soldering, 10 sec.) 300°C
 Operating Temperature Range
 LT1013AM/LT1013M/
 LT1014AM/LT1014M -55°C to 125°C
 LT1013AC/LT1013C/LT1013D
 LT1014AC/LT1014C/LT1014D 0°C to 70°C
 LT1013I/ LT1014I -40°C to 85°C

PACKAGE/ORDER INFORMATION

<p>TOP VIEW</p> <p>OUTPUT A 1 -IN A 2 +IN A 3 +IN B 5 -IN B 6 OUTPUT B 7 V+ 8</p> <p>V+ (CASE) H PACKAGE 8-LEAD TO-5 METAL CAN</p>	<p>ORDER PART NUMBER</p> <p>LT1013AMH LT1013MH LT1013ACH LT1013CH</p>	<p>TOP VIEW</p> <p>OUTPUT A 1 -IN A 2 +IN A 3 V- 4 +IN B 5 -IN B 6 OUTPUT B 7 V+ 8</p> <p>J PACKAGE 8-LEAD CERAMIC DIP N PACKAGE 8-LEAD PLASTIC DIP</p>	<p>ORDER PART NUMBER</p> <p>LT1013AMJ8 LT1013MJ8 LT1013ACJ8 LT1013CJ8 LT1013ACN8 LT1013CN8 LT1013DN8 LT1013IN8</p>	<p>TOP VIEW</p> <p>OUTPUT A 1 -IN A 2 +IN A 3 V+ 4 +IN B 5 -IN B 6 OUTPUT B 7 V- 8 -IN C 9 +IN C 10 -IN D 12 +IN D 13 OUTPUT D 14</p> <p>J PACKAGE 14-LEAD CERAMIC DIP N PACKAGE 14-LEAD PLASTIC DIP</p>	<p>ORDER PART NUMBER</p> <p>LT1014AMJ LT1014MJ LT1014ACJ LT1014CJ LT1014ACN LT1014CN LT1014DN LT1014IN</p>
<p>TOP VIEW</p> <p>+IN A 1 V- 2 +IN B 3 -IN B 4 OUT B 5 V+ 6 OUT A 7 -IN A 8</p> <p>SO PACKAGE 8-LEAD PLASTIC SOIC</p> <p>NOTE: THIS PIN CONFIGURATION DIFFERS FROM THE STANDARD 8-PIN DUAL-IN-LINE CONFIGURATION</p>	<p>ORDER PART NUMBER</p> <p>LT1013DS8 LT1013IS8</p> <p>PART MARKING</p> <p>1013 1013I</p>	<p>TOP VIEW</p> <p>OUTPUT A 1 -IN A 2 +IN A 3 V+ 4 +IN B 5 -IN B 6 OUTPUT B 7 NC 8 NC 9 OUTPUT C 10 -IN C 11 +IN C 12 V- 13 +IN D 14 -IN D 15 OUTPUT D 16</p> <p>SO PACKAGE 16-LEAD PLASTIC SOIC</p>	<p>ORDER PART NUMBER</p> <p>LT1014DS LT1014IS</p> <p>PART MARKING</p> <p>LT1014DS LT1014IS</p>		

ELECTRICAL CHARACTERISTICS

$V_S = \pm 15\text{V}$, $V_{CM} = 0\text{V}$, $T_A = 25^\circ\text{C}$ unless otherwise noted

SYMBOL	PARAMETER	CONDITIONS	LT1013AM/AC LT1014AM/AC			LT1013C/D/I/M LT1014C/D/I/M			UNITS
			MIN	TYP	MAX	MIN	TYP	MAX	
V_{OS}	Input Offset Voltage	LT1013	—	40	150	—	60	300	μV
		LT1014	—	50	180	—	60	300	μV
		LT1013D/I, LT1014D/I	—	—	—	—	200	800	μV
	Long Term Input Offset Voltage Stability		—	0.4	—	—	0.5	—	$\mu\text{V}/\text{Mo.}$
I_{SO}	Input Offset Current		—	0.15	0.8	—	0.2	1.5	nA
I_B	Input Bias Current		—	12	20	—	15	30	nA
e_n	Input Noise Voltage	0.1Hz to 10Hz	—	0.55	—	—	0.55	—	$\mu\text{V}/\sqrt{\text{Hz}}$
e_n	Input Noise Voltage Density	$f_0 = 10\text{Hz}$	—	24	—	—	24	—	$\text{nV}/\sqrt{\text{Hz}}$
		$f_0 = 1000\text{Hz}$	—	22	—	—	22	—	$\text{nV}/\sqrt{\text{Hz}}$
i_n	Input Noise Current Density	$f_0 = 10\text{Hz}$	—	0.07	—	—	0.07	—	$\text{pA}/\sqrt{\text{Hz}}$

ELECTRICAL CHARACTERISTICS

$V_S = \pm 15V$, $V_{CM} = 0V$, $T_A = 25^\circ C$ unless otherwise noted

SYMBOL	PARAMETER	CONDITIONS	LT1013AM/AC LT1014AM/AC			LT1013C/D/I/M LT1014C/D/I/M			UNITS
			MIN	TYP	MAX	MIN	TYP	MAX	
	Input Resistance – Differential Common-Mode	(Note 1)	100 —	400 5	— —	70 —	300 4	— —	M Ω G Ω
A_{VOL}	Large Signal Voltage Gain	$V_O = \pm 10V$, $R_L = 2k$	1.5	8.0	—	1.2	7.0	—	V/ μV
		$V_O = \pm 10V$, $R_L = 600\Omega$	0.8	2.5	—	0.5	2.0	—	V/ μV
	Input Voltage Range		+13.5 –15.0	+13.8 –15.3	— —	+13.5 –15.0	+13.8 –15.3	— —	V V
CMRR	Common-Mode Rejection Ratio	$V_{CM} = +13.5V$, $-15.0V$	100	117	—	97	114	—	dB
PSRR	Power Supply Rejection Ratio	$V_S = \pm 2V$ to $\pm 18V$	103	120	—	100	117	—	dB
	Channel Separation	$V_O = \pm 10V$, $R_L = 2k$	123	140	—	120	137	—	dB
V_{OUT}	Output Voltage Swing	$R_L = 2k$	± 13	± 14	—	± 12.5	± 14	—	V
	Slew Rate		0.2	0.4	—	0.2	0.4	—	V/ μs
I_S	Supply Current	Per Amplifier	—	0.35	0.50	—	0.35	0.55	mA

Note 1: This parameter is guaranteed by design and is not tested. Typical parameters are defined as the 60% yield of parameter distributions of individual amplifiers; i.e., out of 100 LT1014s (or 100 LT1013s) typically 240 op amps (or 120) will be better than the indicated specification.

ELECTRICAL CHARACTERISTICS

$V_S^+ = +5V$, $V_S^- = 0V$, $V_{OUT} = 1.4V$, $V_{CM} = 0V$, $T_A = 25^\circ C$ unless otherwise noted

SYMBOL	PARAMETER	CONDITIONS	LT1013AM/AC LT1014AM/AC			LT1013C/D/I/M LT1014C/D/I/M			UNITS
			MIN	TYP	MAX	MIN	TYP	MAX	
V_{OS}	Input Offset Voltage	LT1013	—	60	250	—	90	450	μV
		LT1014	—	70	280	—	90	450	μV
		LT1013D/I, LT1014D/I	—	—	—	—	250	950	μV
I_{OS}	Input Offset Current		—	0.2	1.3	—	0.3	2.0	nA
I_B	Input Bias Current		—	15	35	—	18	50	nA
A_{VOL}	Large Signal Voltage Gain	$V_O = 5mV$ to $4V$, $R_L = 500\Omega$	—	1.0	—	—	1.0	—	V/ μV
	Input Voltage Range		+3.5 0	+3.8 –0.3	— —	+3.5 0	+3.8 –0.3	— —	V V
V_{OUT}	Output Voltage Swing	Output Low, No Load	—	15	25	—	15	25	mV
		Output Low, 600 Ω to Ground	—	5	10	—	5	10	mV
		Output Low, $I_{SINK} = 1mA$	—	220	350	—	220	350	mV
		Output High, No Load	4.0	4.4	—	4.0	4.4	—	V
		Output High, 600 Ω to Ground	3.4	4.0	—	3.4	4.0	—	V
I_S	Supply Current	Per Amplifier	—	0.31	0.45	—	0.32	0.50	mA

LT1013/LT1014

ELECTRICAL CHARACTERISTICS

$V_S = \pm 15V$, $V_{CM} = 0V$, $-55^\circ C \leq T_A \leq 125^\circ C$ unless otherwise noted

SYMBOL	PARAMETER	CONDITIONS	LT1013AM			LT1014AM			LT1013M/LT1014M			UNITS
			MIN	TYP	MAX	MIN	TYP	MAX	MIN	TYP	MAX	
V_{OS}	Input Offset Voltage	$V_S = +5V$, $V_O = +1.4V$ $-55^\circ C \leq T_A \leq 100^\circ C$ $V_{CM} = 0.1V$, $T_A = 125^\circ C$ $V_{CM} = 0V$, $T_A = 125^\circ C$	● —	80	300	—	90	350	—	110	550	μV
			● —	80	450	—	90	480	—	100	750	μV
			● —	120	450	—	150	480	—	200	750	μV
			● —	250	900	—	300	960	—	400	1500	μV
	Input Offset Voltage Drift	(Note 2)	● —	0.4	2.0	—	0.4	2.0	—	0.5	2.5	$\mu V/^\circ C$
I_{OS}	Input Offset Current	$V_S = +5V$, $V_O = +1.4V$	● —	0.3	2.5	—	0.3	2.8	—	0.4	5.0	nA
			● —	0.6	6.0	—	0.7	7.0	—	0.9	10.0	nA
I_B	Input Bias Current	$V_S = +5V$, $V_O = +1.4V$	● —	15	30	—	15	30	—	18	45	nA
			● —	20	80	—	25	90	—	28	120	nA
A_{VOL}	Large Signal Voltage Gain	$V_O = \pm 10V$, $R_L = 2k$	● 0.5	2.0	—	0.4	2.0	—	0.25	2.0	—	$V/\mu V$
CMRR	Common-Mode Rejection	$V_{CM} = +13.0V$, $-14.9V$	● 97	114	—	96	114	—	94	113	—	dB
PSRR	Power Supply Rejection Ratio	$V_S = \pm 2V$ to $\pm 18V$	● 100	117	—	100	117	—	97	116	—	dB
V_{OUT}	Output Voltage Swing	$R_L = 2k$ $V_S = +5V$, $0V$ $R_L = 600\Omega$ to Ground Output Low Output High	● ± 12	± 13.8	—	± 12	± 13.8	—	± 11.5	± 13.8	—	V
			● —	6	15	—	6	15	—	6	18	mV
			● 3.2	3.8	—	3.2	3.8	—	3.1	3.8	—	V
			● —	0.38	0.60	—	0.38	0.60	—	0.38	0.7	mA
I_S	Supply Current Per Amplifier	$V_S = +5V$, $V_O = +1.4V$	● —	0.38	0.60	—	0.38	0.60	—	0.38	0.7	mA
			● —	0.34	0.55	—	0.34	0.55	—	0.34	0.65	mA

ELECTRICAL CHARACTERISTICS

$V_S = \pm 15V$, $V_{CM} = 0V$, $-40^\circ C \leq T_A \leq 85^\circ C$ for LT1013I, LT1014I, $0^\circ C \leq T_A \leq 70^\circ C$ for LT1013C, LT1013D, LT1014C, LT1014D unless otherwise noted

SYMBOL	PARAMETER	CONDITIONS	LT1013AC			LT1014AC			LT1013C/D/I LT1014C/D/I			UNITS	
			MIN	TYP	MAX	MIN	TYP	MAX	MIN	TYP	MAX		
V_{OS}	Input Offset Voltage	LT1013D/I, LT1014D/I $V_S = +5V$, $V_O = 1.4V$ LT1013D/I, LT1014D/I $V_S = +5V$, $V_O = 1.4V$	● —	55	240	—	65	270	—	80	400	μV	
			● —	—	—	—	—	—	—	—	230	1000	μV
			● —	75	350	—	85	380	—	110	570	μV	
			● —	—	—	—	—	—	—	—	280	1200	μV
	Average Input Offset Voltage Drift	(Note 2) LT1013D/I, LT1014D/I	● —	0.3	2.0	—	0.3	2.0	—	0.4	2.5	$\mu V/^\circ C$	
			● —	—	—	—	—	—	—	0.7	5.0	$\mu V/^\circ C$	
I_{OS}	Input Offset Current	$V_S = +5V$, $V_O = 1.4V$	● —	0.2	1.5	—	0.2	1.7	—	0.3	2.8	nA	
			● —	0.4	3.5	—	0.4	4.0	—	0.5	6.0	nA	
I_B	Input Bias Current	$V_S = +5V$, $V_O = 1.4V$	● —	13	25	—	13	25	—	16	38	nA	
			● —	18	55	—	20	60	—	24	90	nA	
A_{VOL}	Large Signal Voltage Gain	$V_O = \pm 10V$, $R_L = 2k$	● 1.0	5.0	—	1.0	5.0	—	0.7	4.0	—	$V/\mu V$	
CMRR	Common-Mode Rejection Ratio	$V_{CM} = +13.0V$, $-15.0V$	● 98	116	—	98	116	—	94	113	—	dB	
PSRR	Power Supply Rejection Ratio	$V_S = \pm 2V$ to $\pm 18V$	● 101	119	—	101	119	—	97	116	—	dB	
V_{OUT}	Output Voltage Swing	$R_L = 2k$ $V_S = +5V$, $0V$; $R_L = 600\Omega$ Output Low Output High	● ± 12.5	± 13.9	—	± 12.5	± 13.9	—	± 12.0	± 13.9	—	V	
			● —	6	13	—	6	13	—	6	13	mV	
			● 3.3	3.9	—	3.3	3.9	—	3.2	3.9	—	V	
			● —	0.36	0.55	—	0.36	0.55	—	0.37	0.60	mA	
I_S	Supply Current per Amplifier	$V_S = +5V$, $V_O = 1.4V$	● —	0.36	0.55	—	0.36	0.55	—	0.37	0.60	mA	
			● —	0.32	0.50	—	0.32	0.50	—	0.34	0.55	mA	

Note 2: This parameter is not 100% tested.

The ● denotes specifications which apply over the full operating temperature range.

TYPICAL PERFORMANCE CHARACTERISTICS

Offset Voltage Drift with Temperature of Representative Units

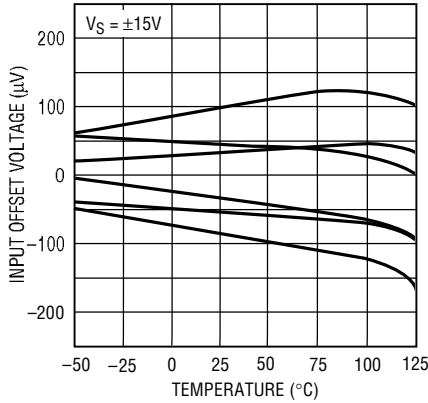

Offset Voltage vs Balanced Source Resistance

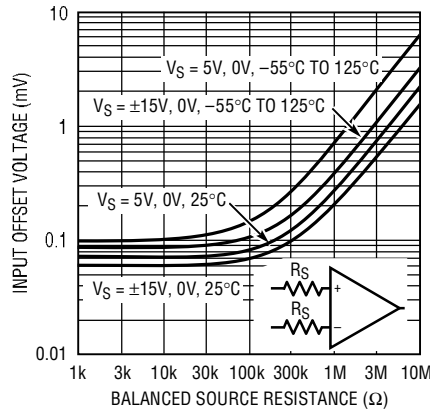

Warm-Up Drift

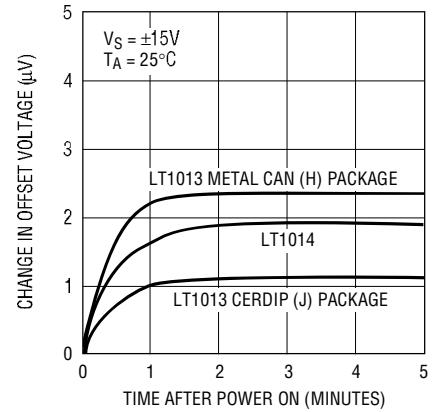

Common-Mode Rejection Ratio vs Frequency

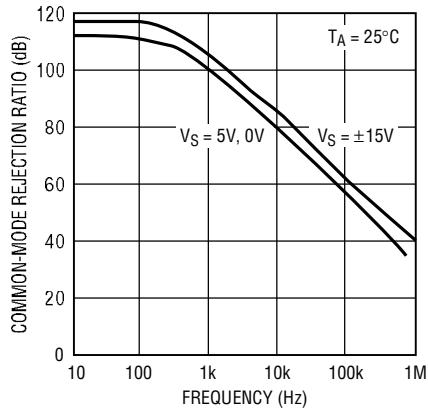

Power Supply Rejection Ratio vs Frequency

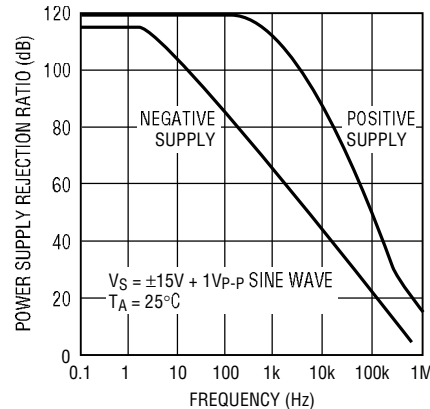

0.1Hz to 10Hz Noise

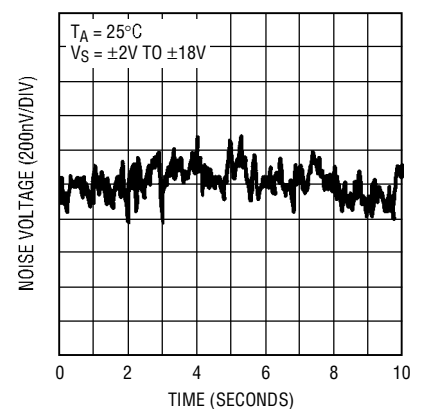

Noise Spectrum

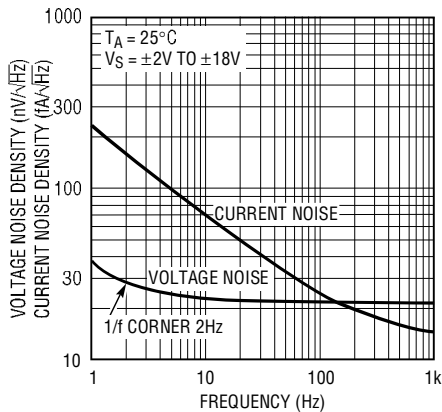

10Hz Voltage Noise Distribution

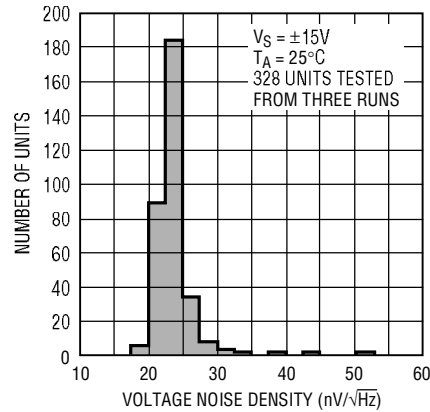

Supply Current vs Temperature

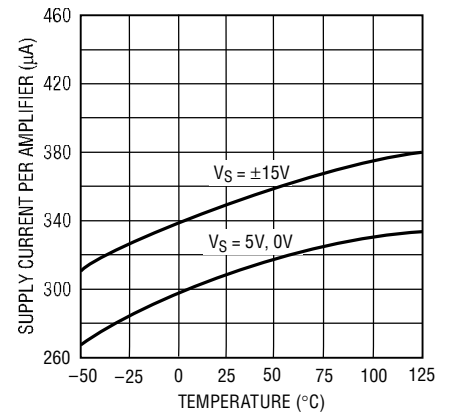

TYPICAL PERFORMANCE CHARACTERISTICS

Input Bias Current vs Common-Mode Voltage

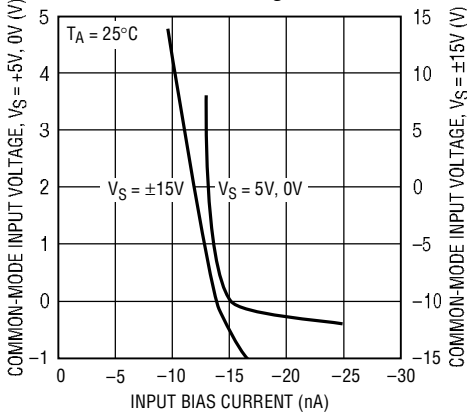

Input Offset Current vs Temperature

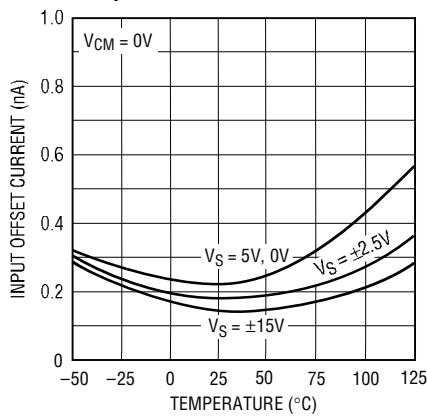

Input Bias Current vs Temperature

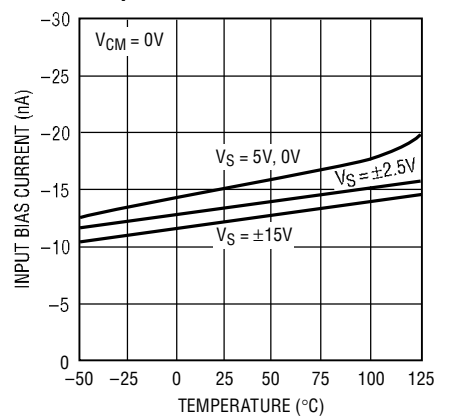

Output Saturation vs Sink Current vs Temperature

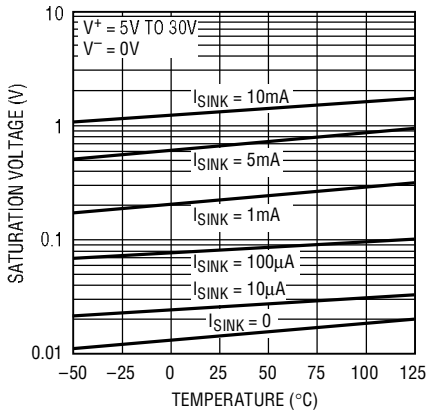

Small Signal Transient Response, $V_S = \pm 15\text{V}$

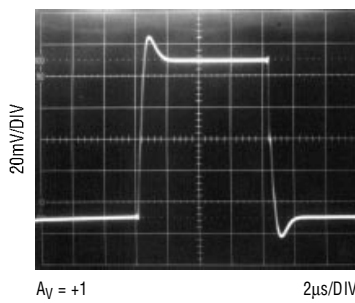

Large Signal Transient Response, $V_S = \pm 15\text{V}$

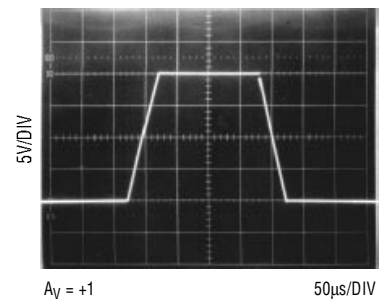

Small Signal Transient Response, $V_S = 5\text{V}, 0\text{V}$

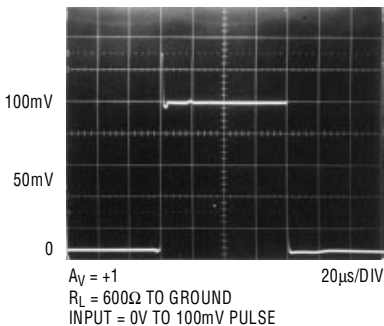

Large Signal Transient Response, $V_S = 5\text{V}, 0\text{V}$

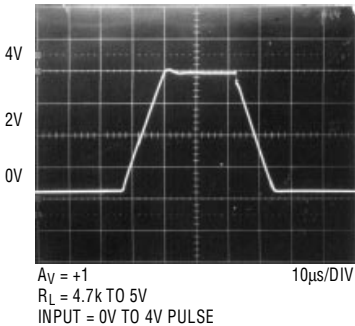

Large Signal Transient Response, $V_S = 5\text{V}, 0\text{V}$

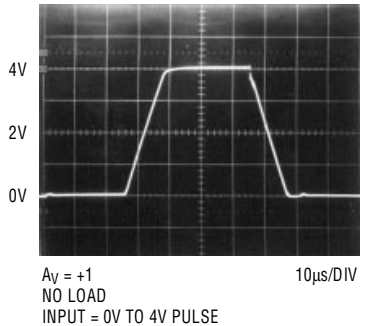

TYPICAL PERFORMANCE CHARACTERISTICS

Output Short Circuit Current vs Time

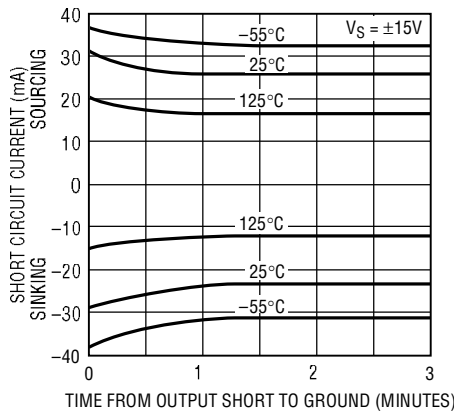

Voltage Gain vs Load Resistance

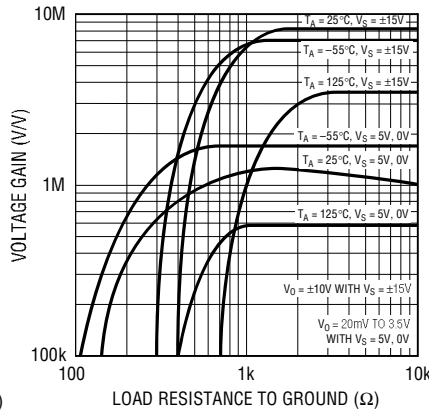

Voltage Gain vs Frequency

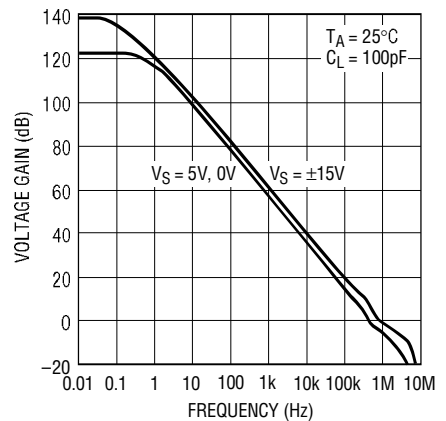

Gain, Phase vs Frequency

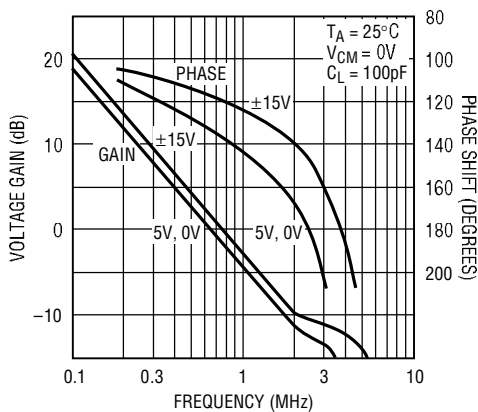

Channel Separation vs Frequency

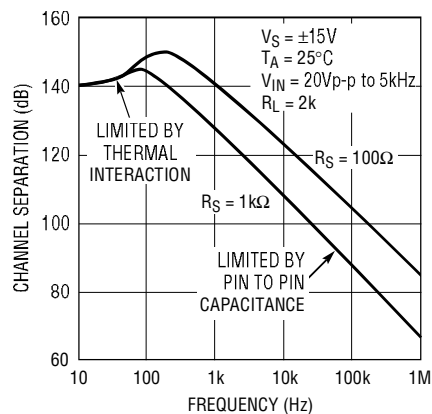

APPLICATIONS INFORMATION

Single Supply Operation

The LT1013/1014 are fully specified for single supply operation, i.e., when the negative supply is 0V. Input common-mode range includes ground; the output swings within a few millivolts of ground. Single supply operation, however, can create special difficulties, both at the input and at the output. The LT1013/LT1014 have specific circuitry which addresses these problems.

At the input, the driving signal can fall below 0V— inadvertently or on a transient basis. If the input is more than

a few hundred millivolts below ground, two distinct problems can occur on previous single supply designs, such as the LM124, LM158, OP-20, OP-21, OP-220, OP-221, OP-420:

a) When the input is more than a diode drop below ground, unlimited current will flow from the substrate (V^- terminal) to the input. This can destroy the unit. On the LT1013/1014, the 400Ω resistors, in series with the input (see schematic diagram), protect the devices even when the input is 5V below ground.

APPLICATIONS INFORMATION

(b) When the input is more than 400mV below ground (at 25°C), the input stage saturates (transistors Q3 and Q4) and phase reversal occurs at the output. This can cause lock-up in servo systems. Due to a unique phase reversal protection circuitry (Q21, Q22, Q27, Q28), the LT1013/1014's outputs do not reverse, as illustrated below, even when the inputs are at -1.5V.

There is one circumstance, however, under which the phase reversal protection circuitry does not function: when the other op amp on the LT1013, or one specific amplifier of the other three on the LT1014, is driven hard into negative saturation at the output.

Phase reversal protection does not work on amplifier:
 A when D's output is in negative saturation. B's and C's outputs have no effect.

B when C's output is in negative saturation. A's and D's outputs have no effect.

C when B's output is in negative saturation. A's and D's outputs have no effect.

D when A's output is in negative saturation. B's and C's outputs have no effect.

At the output, the aforementioned single supply designs either cannot swing to within 600mV of ground (OP-20) or cannot sink more than a few microamperes while swinging to ground (LM124, LM158). The LT1013/1014's all-NPN output stage maintains its low output resistance and high gain characteristics until the output is saturated.

In dual supply operations, the output stage is crossover distortion-free.

Comparator Applications

The single supply operation of the LT1013/1014 lends itself to its use as a precision comparator with TTL compatible output:

In systems using both op amps and comparators, the LT1013/1014 can perform multiple duties; for example, on the LT1014, two of the devices can be used as op amps and the other two as comparators.

Voltage Follower with Input Exceeding the Negative Common-Mode Range

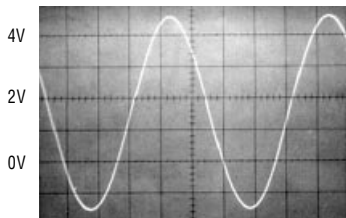

6Vp-p INPUT, -1.5V TO 4.5V

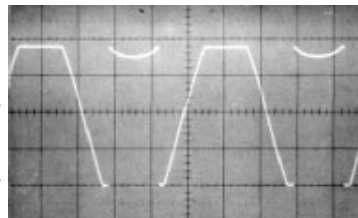

LM324, LM358, OP-20
EXHIBIT OUTPUT PHASE
REVERSAL

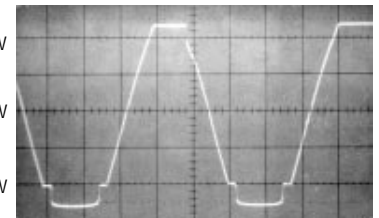

LT1013/LT1014
NO PHASE REVERSAL

Comparator Rise Response Time 10mV, 5mV, 2mV Overdrives

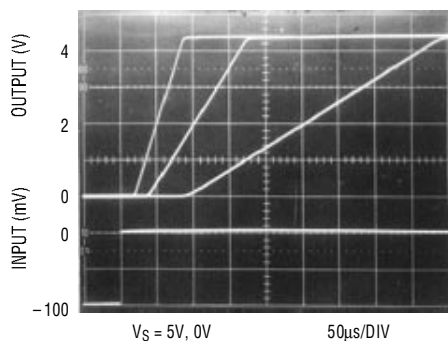

Comparator Fall Response Time to 10mV, 5mV, 2mV Overdrives

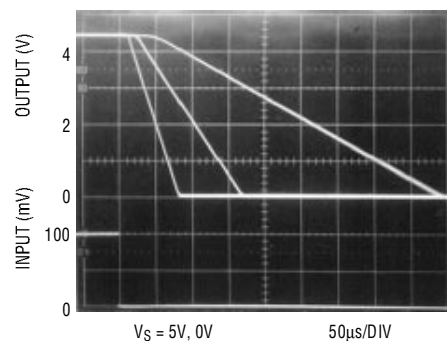

APPLICATIONS INFORMATION

Low Supply Operation

The minimum supply voltage for proper operation of the LT1013/1014 is 3.4V (three Ni-Cad batteries). Typical supply current at this voltage is 290 μ A, therefore power dissipation is only one milliwatt per amplifier.

Noise Testing

For applications information on noise testing and calculations, please see the LT1007 or LT1008 data sheet.

Test Circuit for Offset Voltage and Offset Drift with Temperature

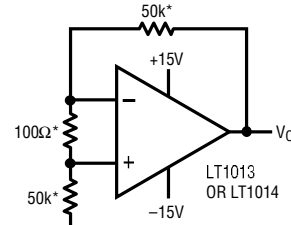

*RESISTOR MUST HAVE LOW THERMOELECTRIC POTENTIAL.
 **THIS CIRCUIT IS ALSO USED AS THE BURN-IN CONFIGURATION, WITH SUPPLY VOLTAGES INCREASED TO $\pm 20V$.
 $V_O = 1000V_{OS}$

TYPICAL APPLICATIONS

50MHz Thermal rms to DC Converter

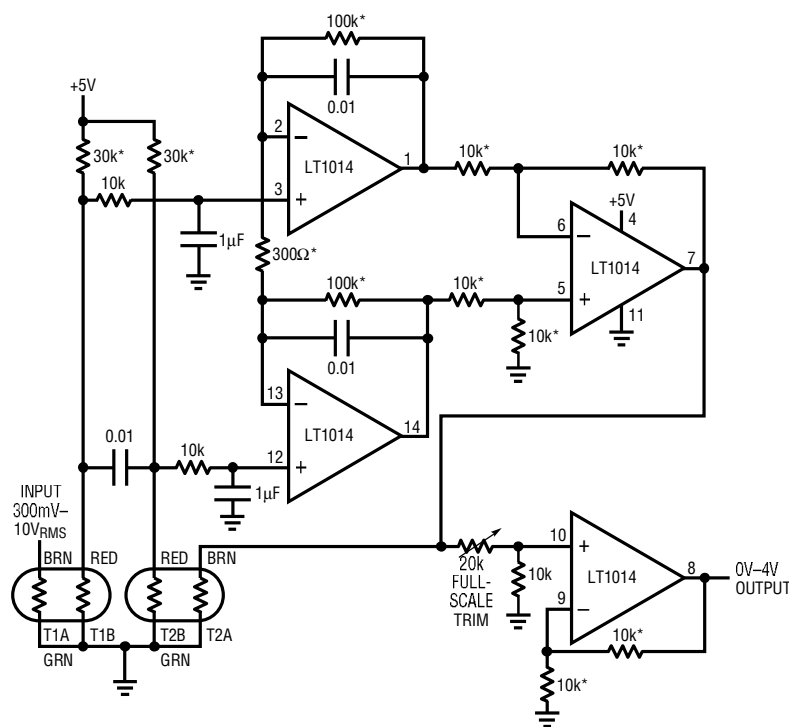

2% ACCURACY, DC-50MHz.
 100:1 CREST FACTOR CAPABILITY.
 * 0.1% RESISTOR.
 T1-T2 = YELLOW SPRINGS INST. CO. THERMISTOR COMPOSITE #44018.
 ENCLOSE T1 AND T2 IN STYROFOAM.
 7.5mW DISSIPATION.

5V Single Supply Dual Instrumentation Amplifier

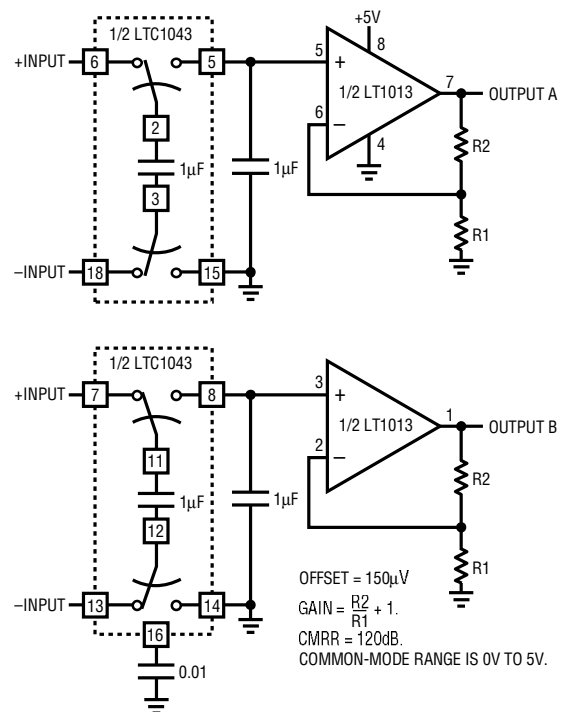

OFFSET = 150 μ V
 GAIN = $\frac{R2}{R1} + 1$.
 CMRR = 120dB.
 COMMON-MODE RANGE IS 0V TO 5V.

TYPICAL APPLICATIONS

Hot Wire Anemometer

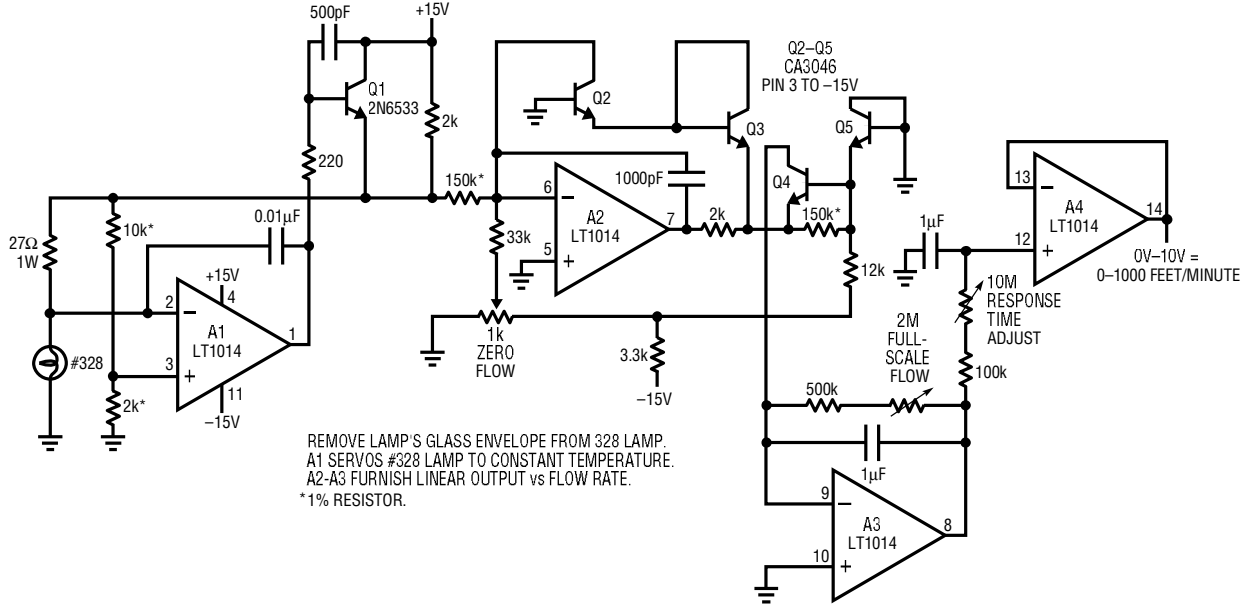

Liquid Flowmeter

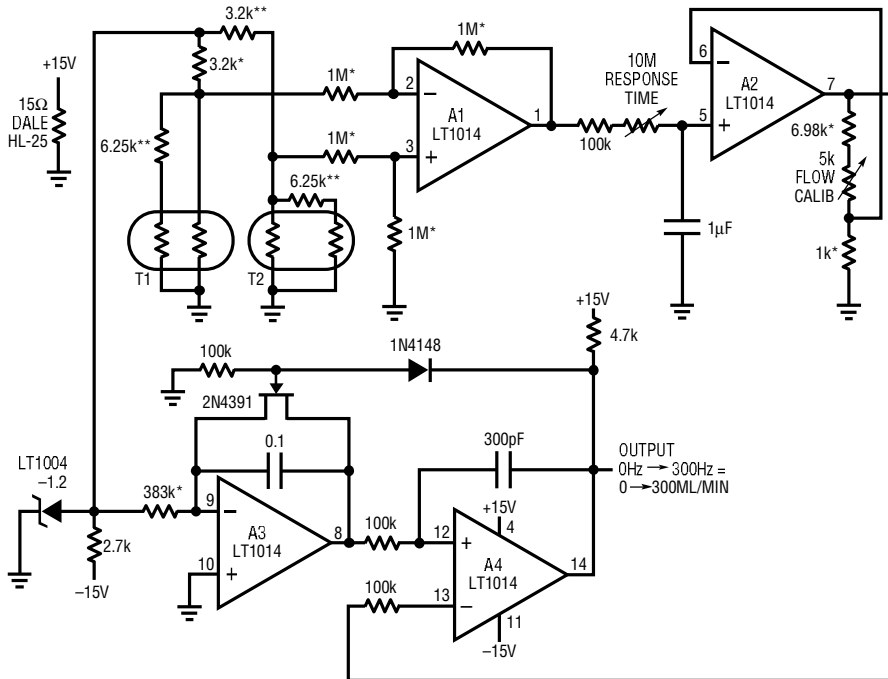

* 1% FILM RESISTOR.
 ** SUPPLIED WITH YSI THERMISTOR NETWORK. T1, T2 YSI THERMISTOR NETWORK = #44201. FLOW IN PIPE IS INVERSELY PROPORTIONAL TO RESISTANCE OF T1-T2 TEMPERATURE DIFFERENCE. A1-A2 PROVIDE GAIN. A3-A4 PROVIDE LINEARIZED FREQUENCY OUTPUT.

TYPICAL APPLICATIONS

5V Powered Precision Instrumentation Amplifier

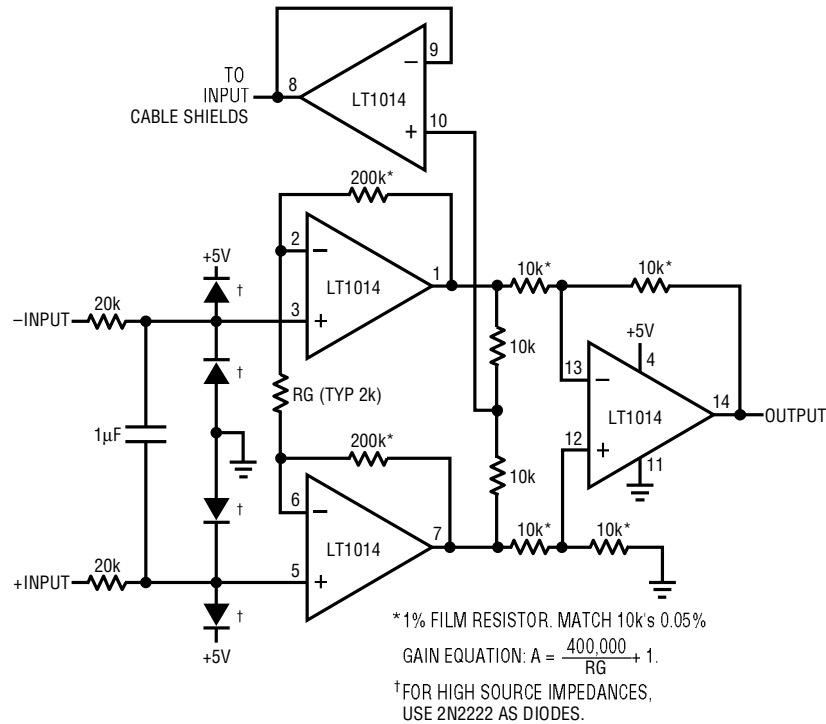

9V Battery Powered Strain Gauge Signal Conditioner

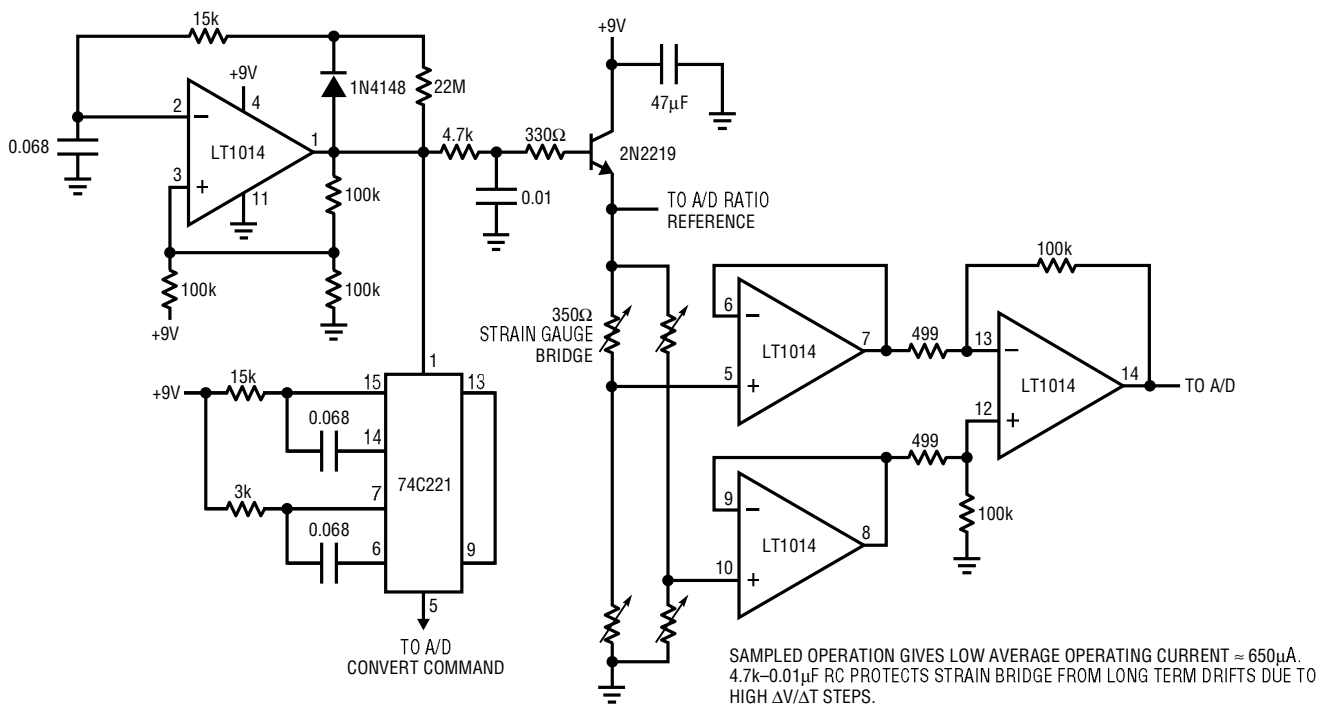

TYPICAL APPLICATIONS

**5V Powered Motor Speed Controller
No Tachometer Required**

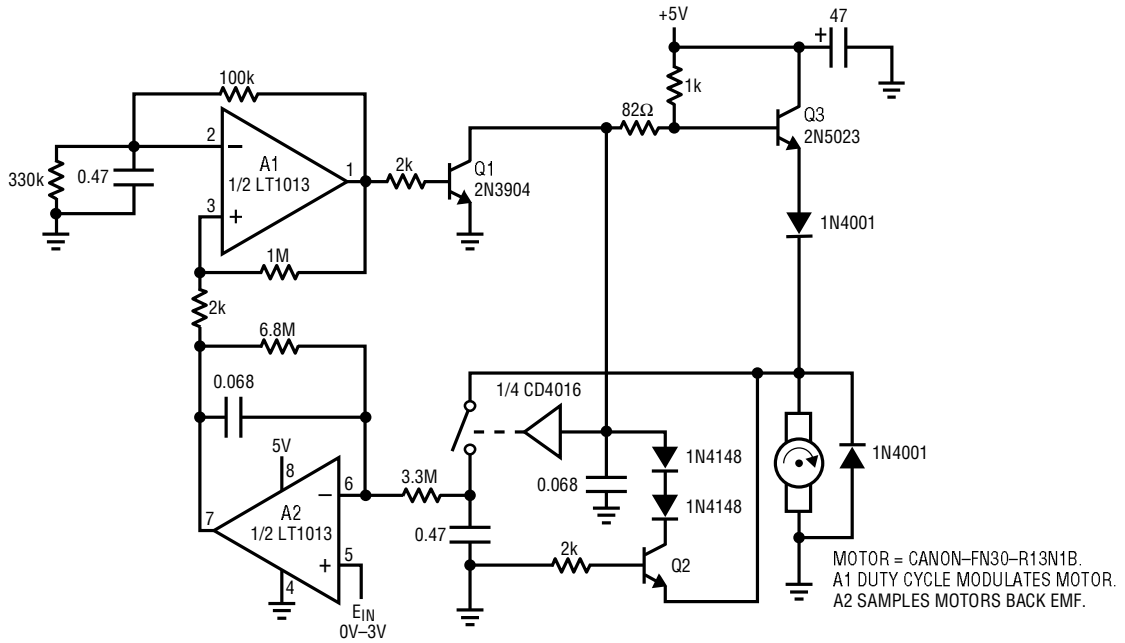

5V Powered EEPROM Pulse Generator

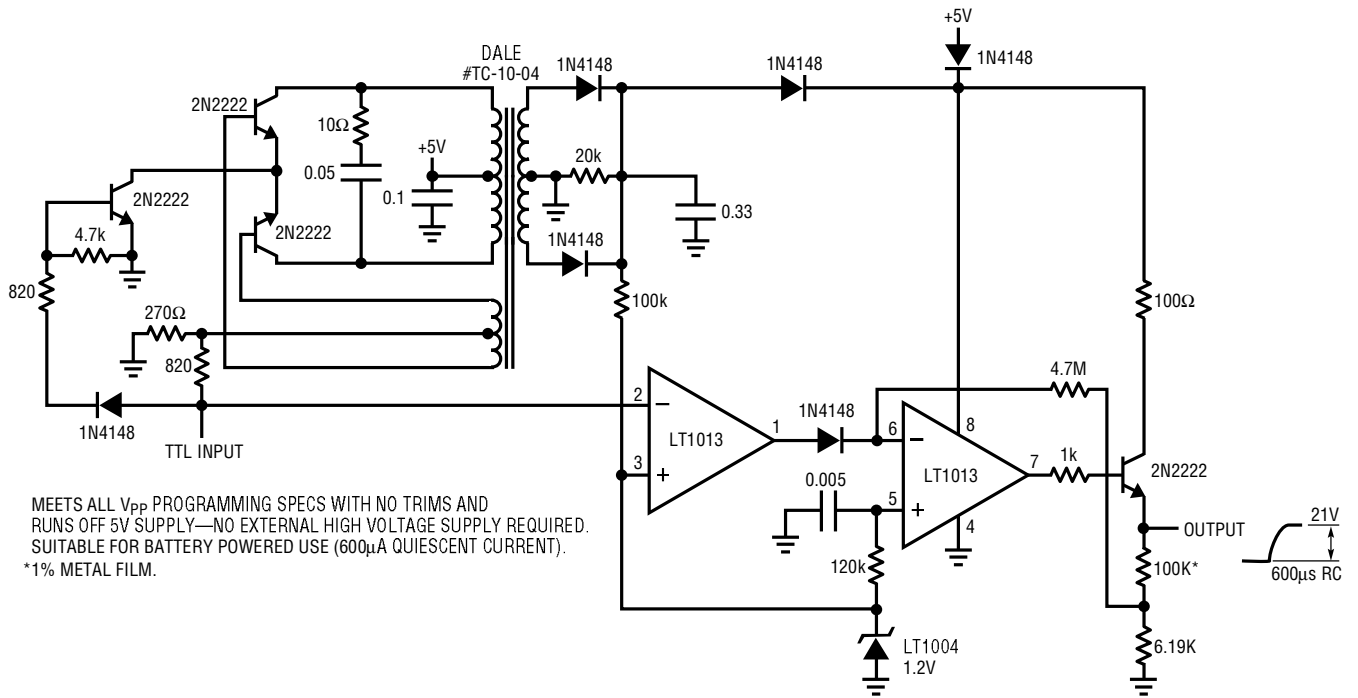

TYPICAL APPLICATIONS

Methane Concentration Detector with Linearized Output

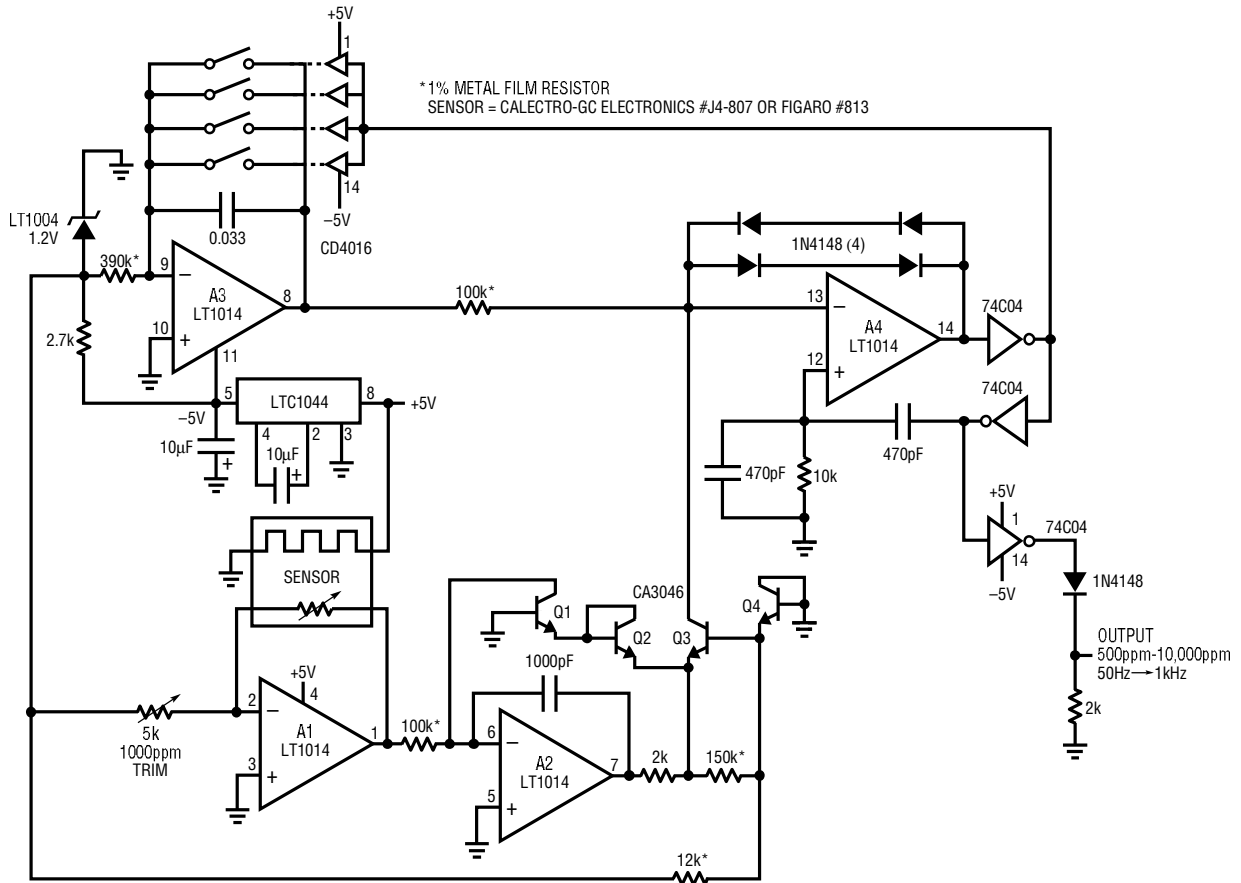

Low Power 9V to 5V Converter

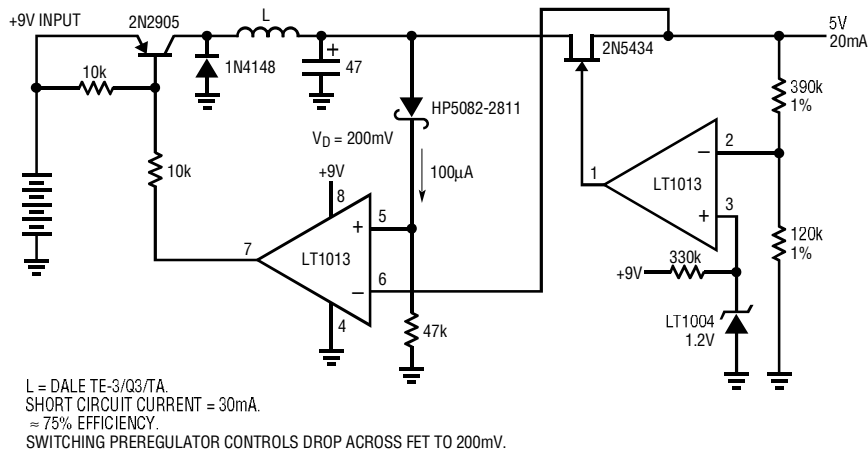

TYPICAL APPLICATIONS

5V Powered 4mA–20mA Current Loop Transmitter†

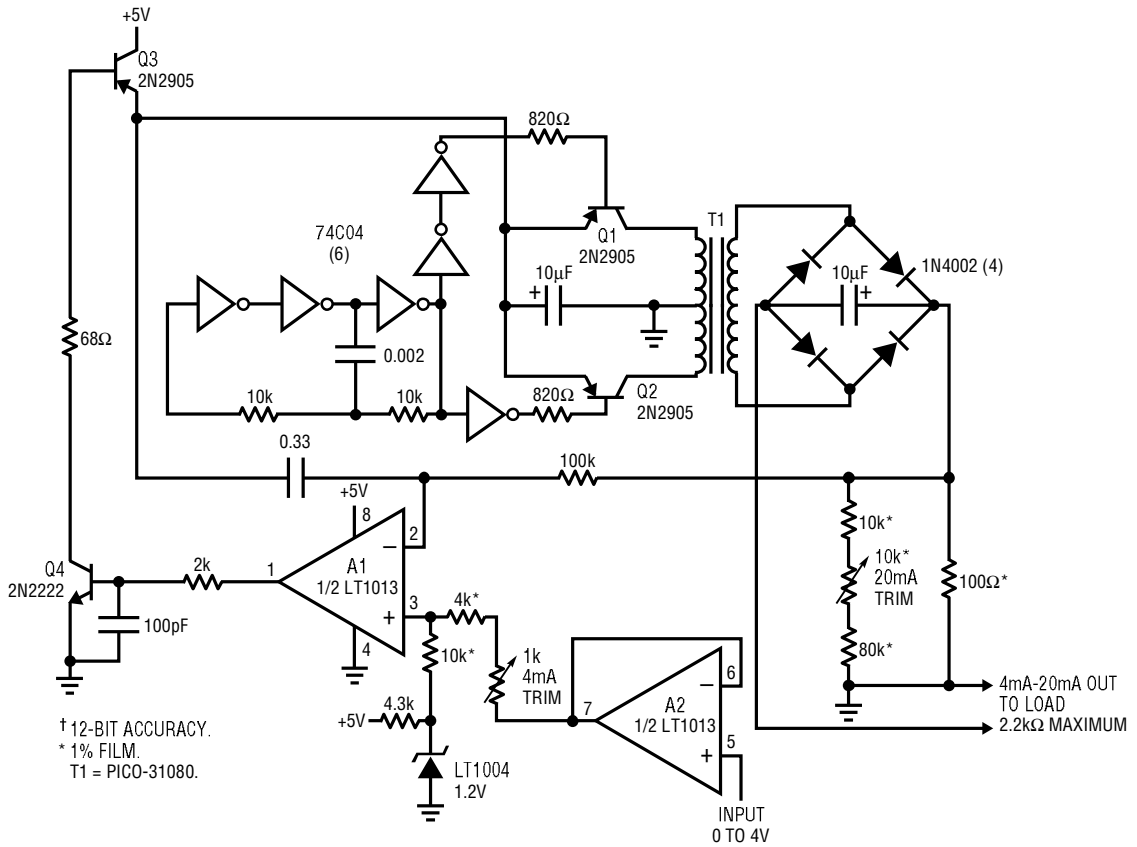

Fully Floating Modification to 4mA–20mA Current Loop†

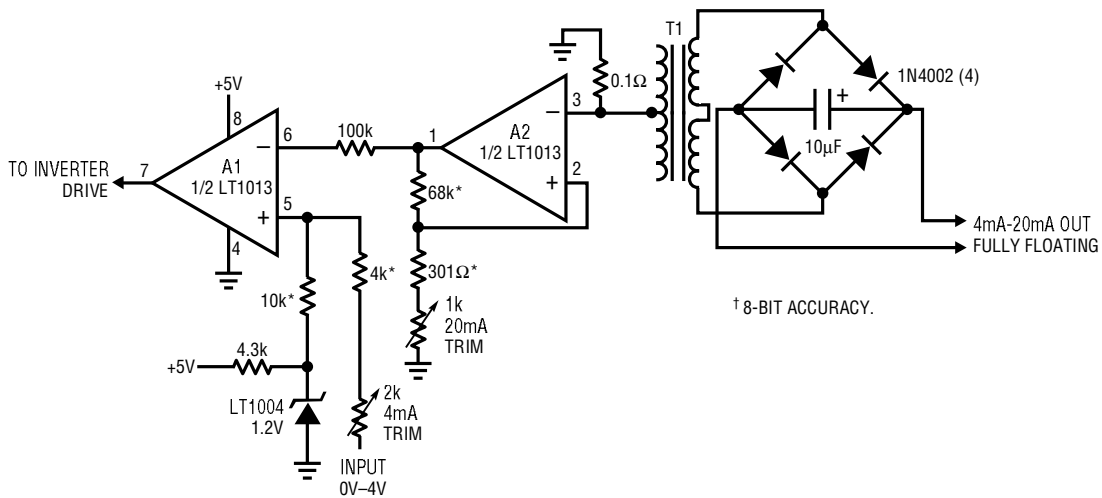

TYPICAL APPLICATIONS

5V Powered, Linearized Platinum RTD Signal Conditioner

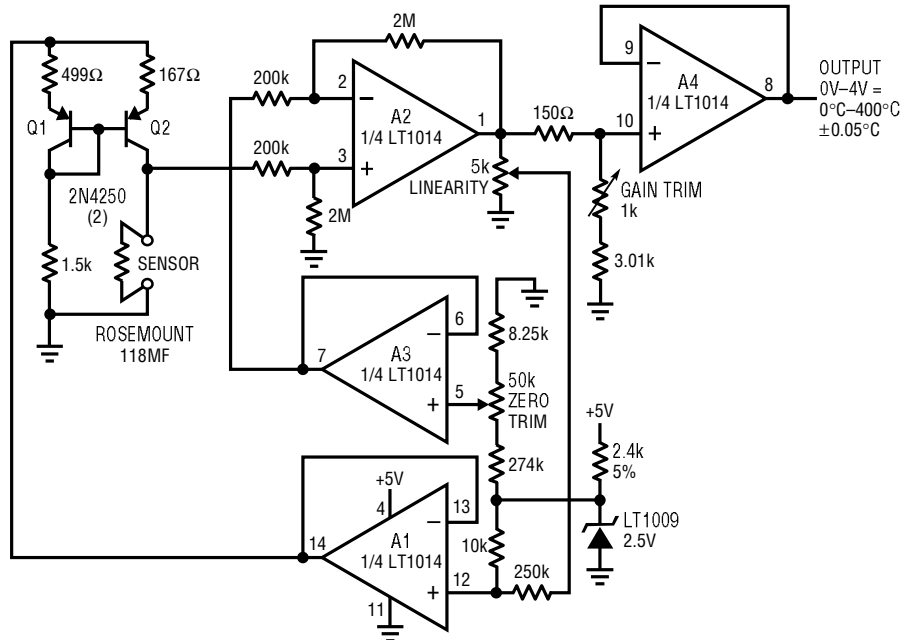

ALL RESISTORS ARE TRW-MAR-6 METAL FILM.
 RATIO MATCH 2M-200K ± 0.01%.
 TRIM SEQUENCE:
 SET SENSOR TO 0° VALUE.
 ADJUST ZERO FOR 0V OUT.
 SET SENSOR TO 100 °C VALUE.
 ADJUST GAIN FOR 1.000V OUT.
 SET SENSOR TO 400 °C.
 ADJUST LINEARITY FOR 4.000V OUT, REPEAT AS REQUIRED.

Strain Gauge Bridge Signal Conditioner

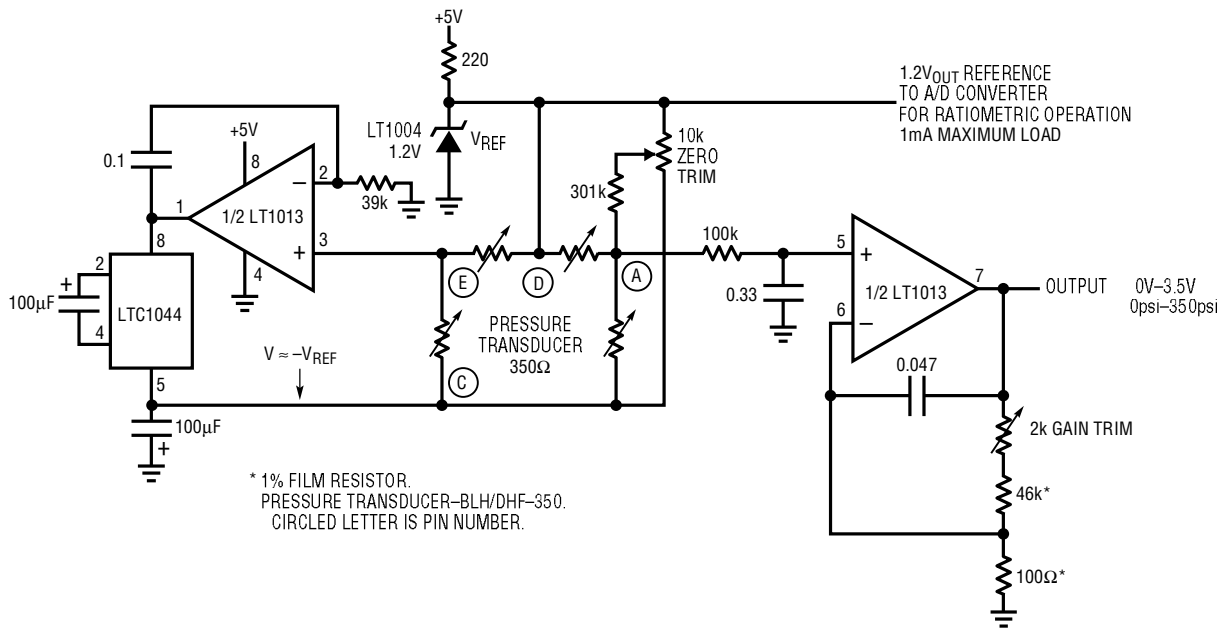

* 1% FILM RESISTOR.
 PRESSURE TRANSDUCER-BLH/DHF-350.
 CIRCLED LETTER IS PIN NUMBER.

TYPICAL APPLICATIONS

LVDT Signal Conditioner

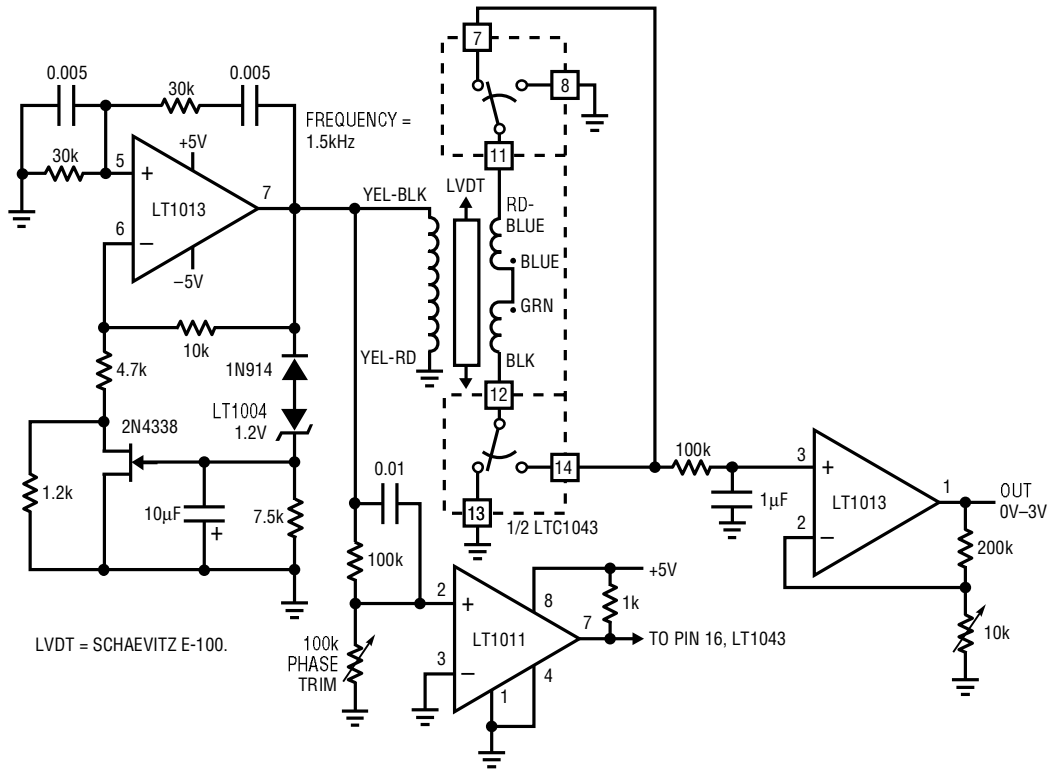

Triple Op Amp Instrumentation Amplifier with Bias Current Cancellation

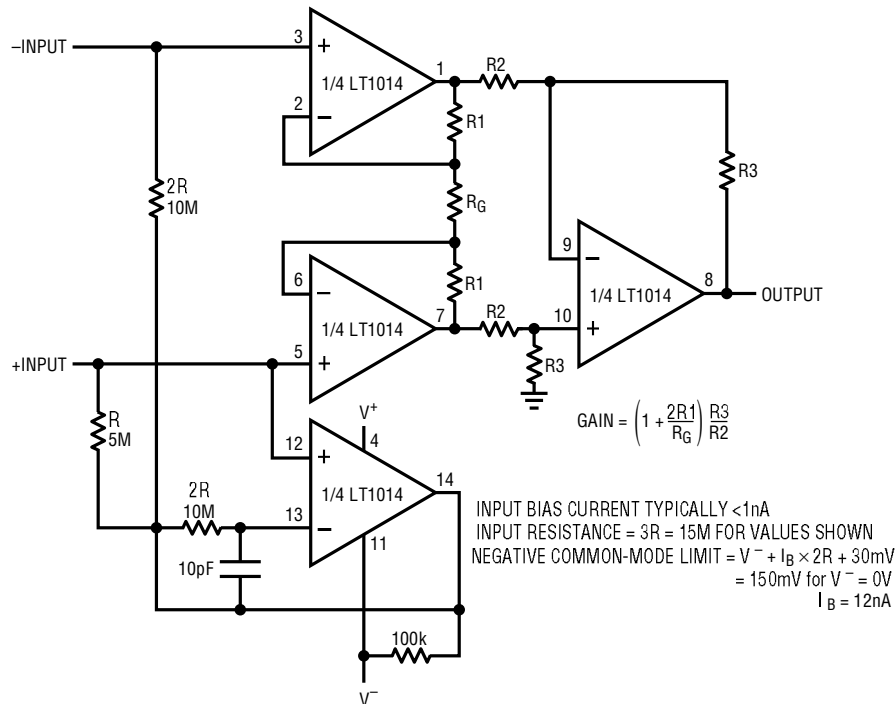

TYPICAL APPLICATIONS

Low Dropout Regulator for 6V Battery

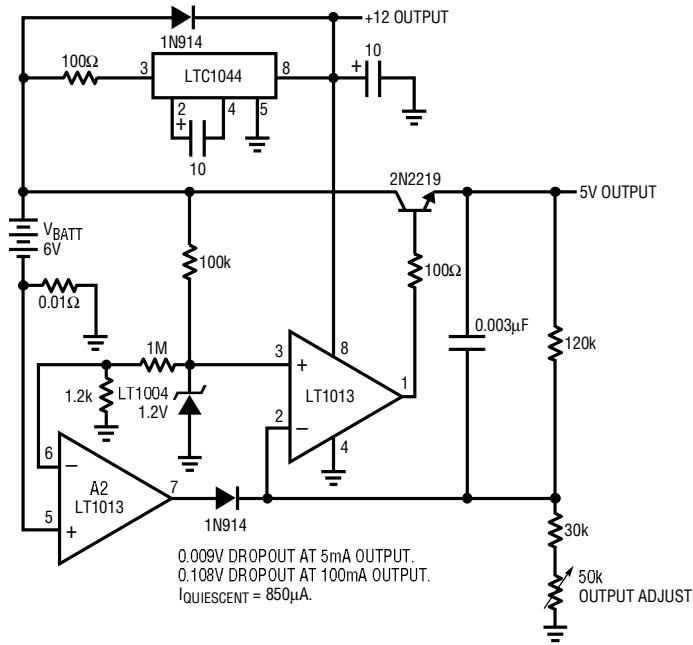

Voltage Controlled Current Source with Ground Referred Input and Output

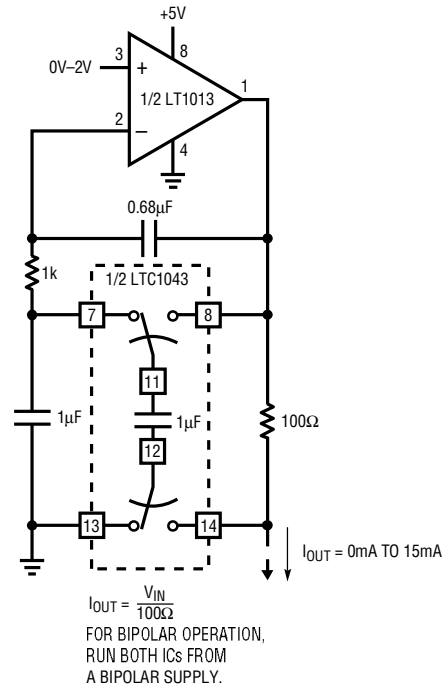

6V to ±15V Regulating Converter

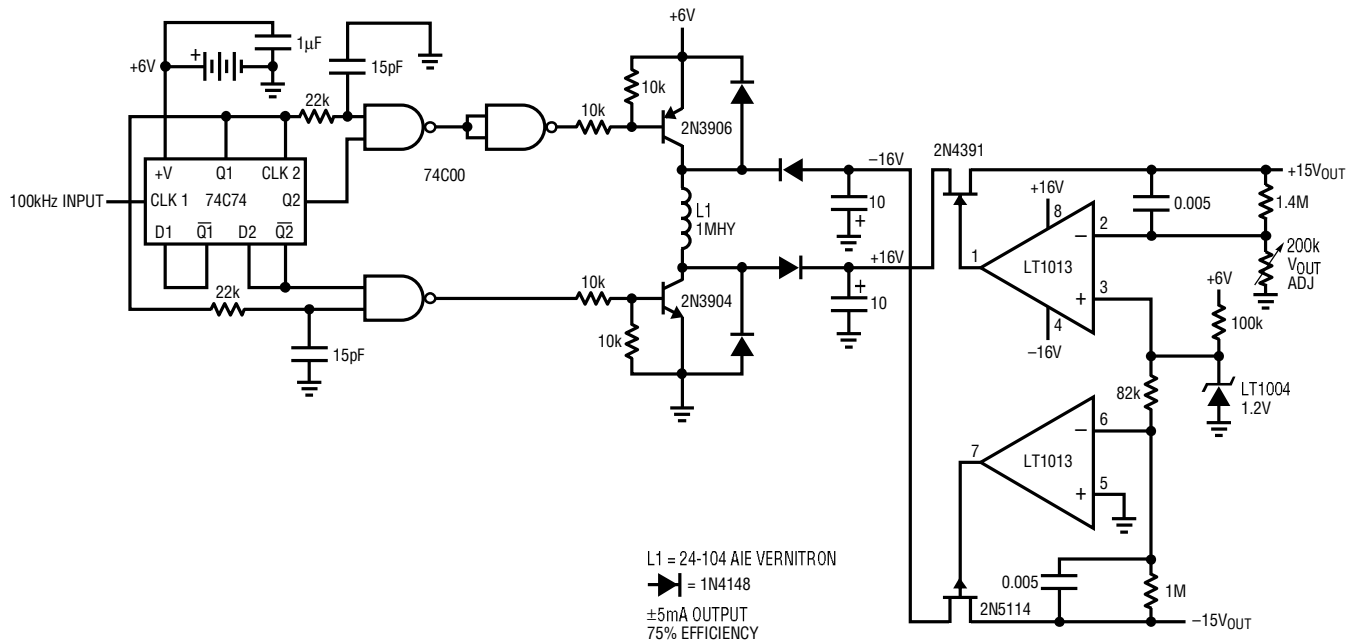

TYPICAL APPLICATIONS

Low Power, 5V Driven, Temperature Compensated Crystal Oscillator (TXCO)†

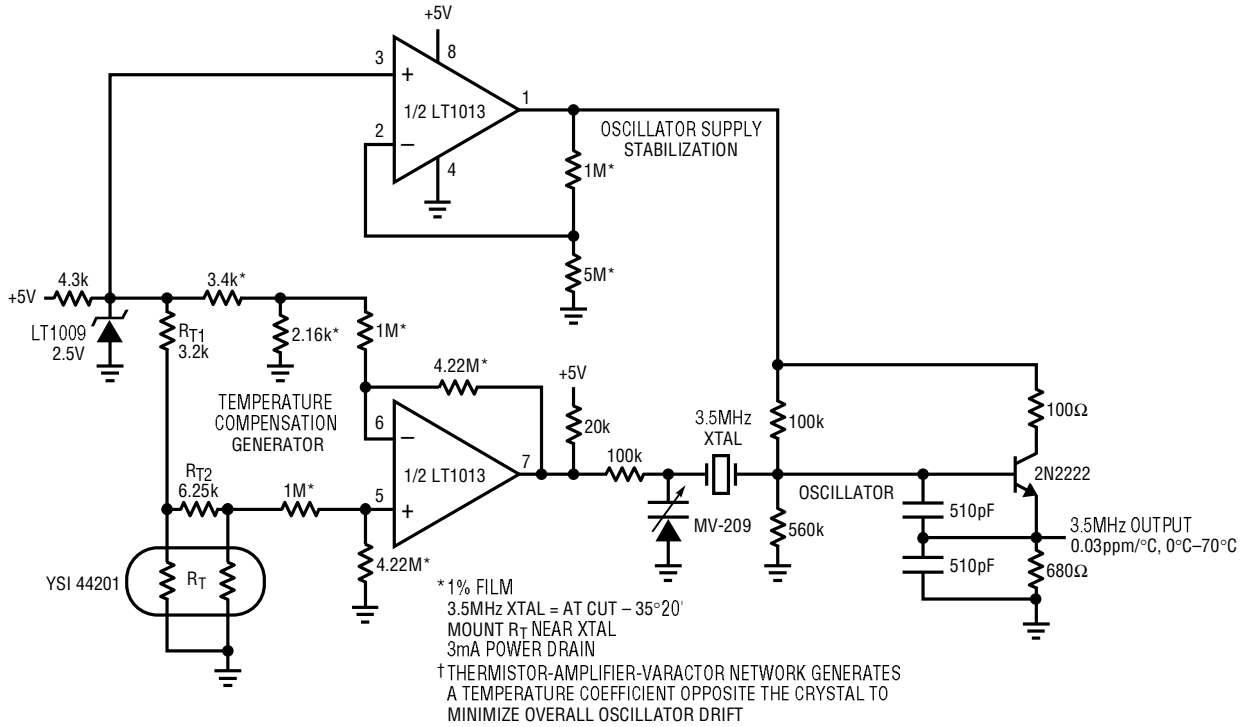

Step-Up Switching Regulator for 6V Battery

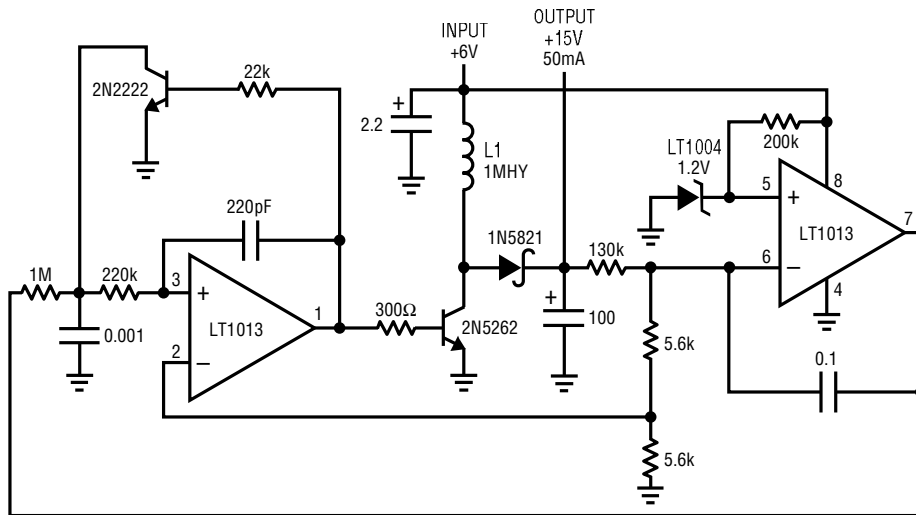

LT = AIE-VERNITRON 24-104
78% EFFICIENCY

SCHEMATIC DIAGRAM

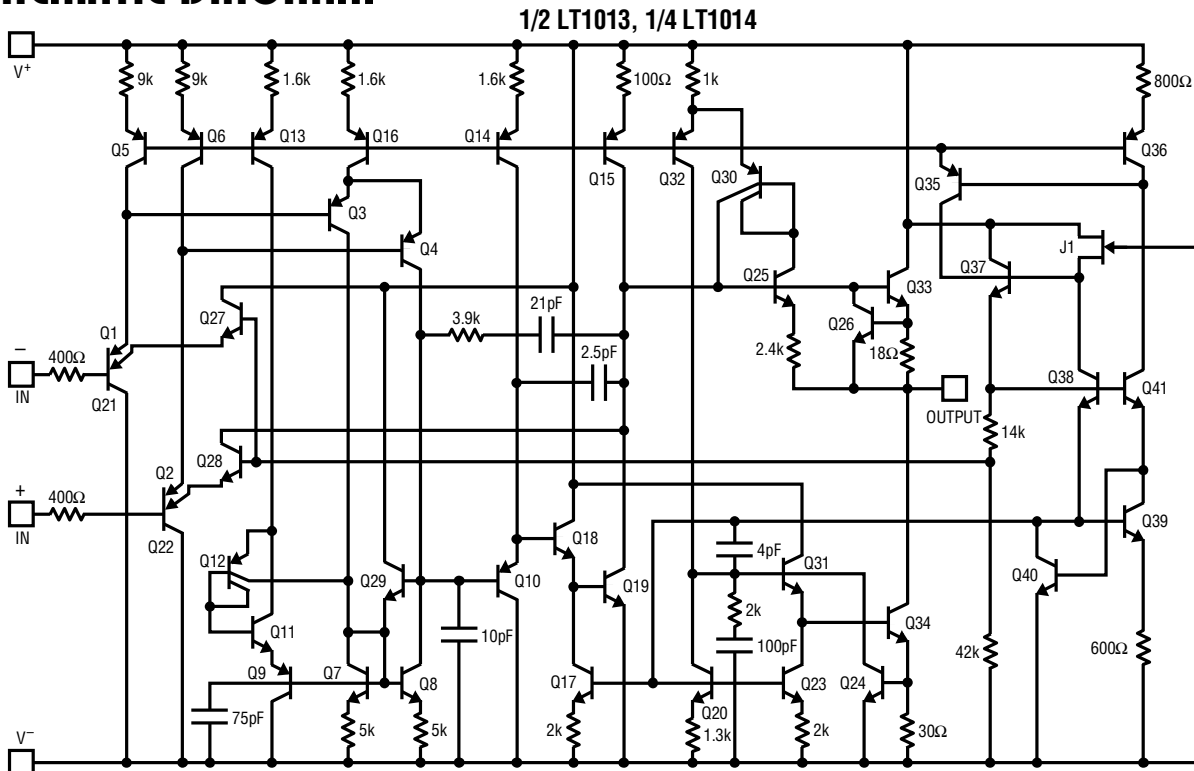

J8 Package
8-Lead CERDIP (Narrow 0.300, Hermetic)
 (LTC DWG # 05-08-1110)

N8 Package
8-Lead PDIP (Narrow 0.300)
 (LTC DWG # 05-08-1510)

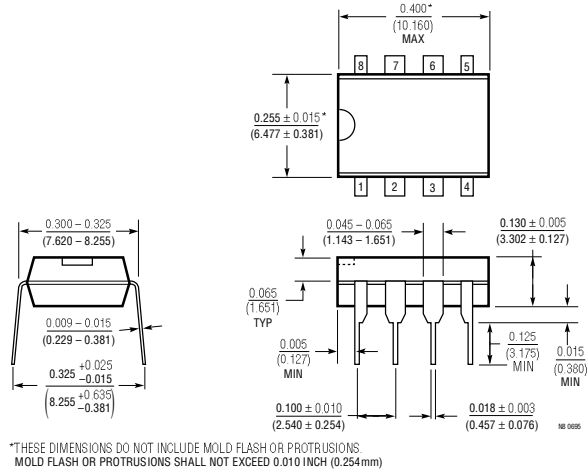
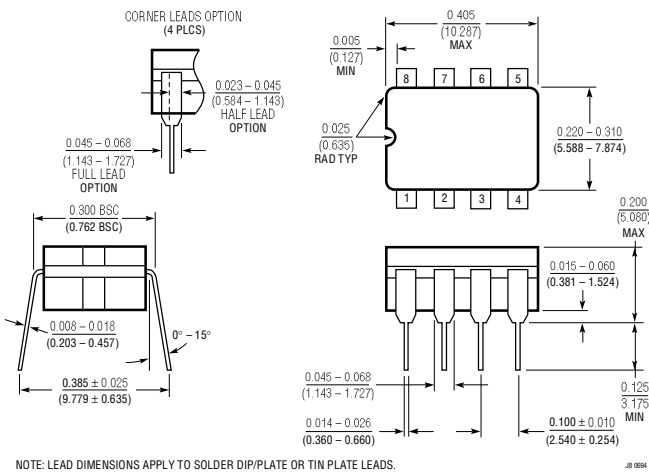

T_{jmax}	θ_{ja}
150°C	100°C/W

T_{jmax}	θ_{ja}
100°C	130°C/W

PACKAGE DESCRIPTION

H Package
8-Lead TO-5 Metal Can (0.200 PCD)
 (LTC DWG # 05-08-1320)

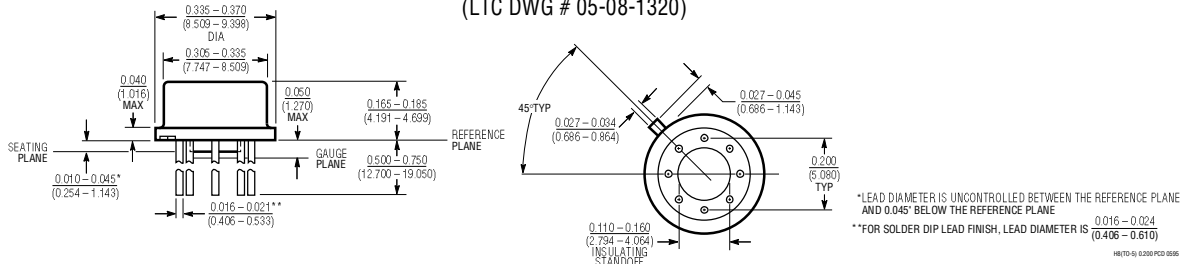

NOTE: DIMENSIONS IN INCHES (MILLIMETERS)

T_{max} 150°C	θ_{ja} 150°C/W	θ_{jc} 45°C/W
--------------------	--------------------------	-------------------------

J Package
14-Lead CERDIP (Narrow 0.300, Hermetic)
 (LTC DWG # 05-08-1110)

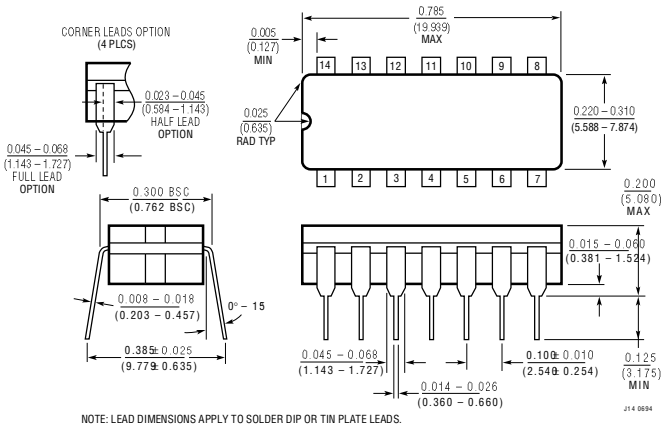

NOTE: LEAD DIMENSIONS APPLY TO SOLDER DIP OR TIN PLATE LEADS.

T_{max} 150°C	θ_{ja} 100°C/W
--------------------	--------------------------

N Package
14-Lead PDIP (Narrow 0.300)
 (LTC DWG # 05-08-1510)

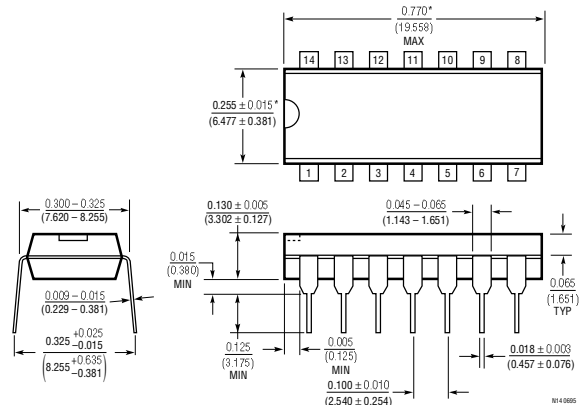

*THESE DIMENSIONS DO NOT INCLUDE MOLD FLASH OR PROTRUSIONS. MOLD FLASH OR PROTRUSIONS SHALL NOT EXCEED 0.010 INCH (0.254mm)

T_{max} 100°C	θ_{ja} 100°C/W
--------------------	--------------------------

S8 Package
8-Lead Plastic Small Outline (Narrow 0.150)
 (LTC DWG # 05-08-1610)

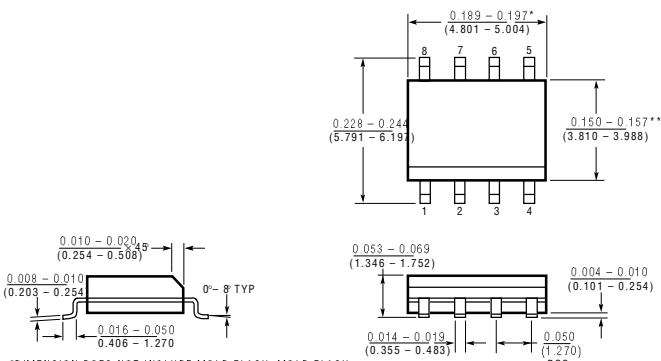

DIMENSION DOES NOT INCLUDE MOLD FLASH. MOLD FLASH SHALL NOT EXCEED 0.006 (0.152mm) PER SIDE
 **DIMENSION DOES NOT INCLUDE INTERLEAD FLASH. INTERLEAD FLASH SHALL NOT EXCEED 0.010* (0.254mm) PER SIDE

SW Package
16-Lead Plastic Small Outline (Wide 0.300)
 (LTC DWG # 05-08-1620)

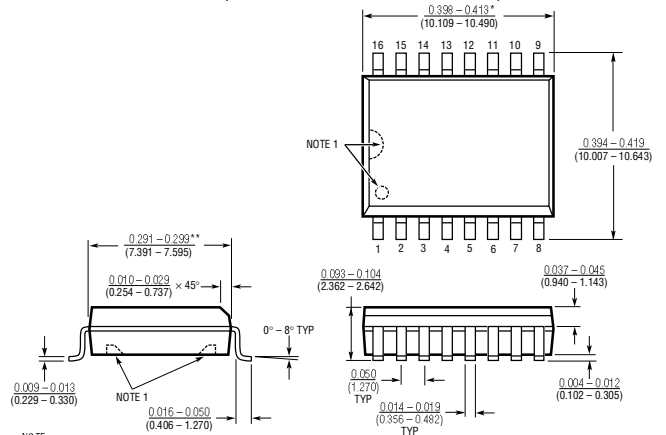

NOTE:
 1. PIN 1 IDENT. NOTCH ON TOP AND CAVITIES ON THE BOTTOM OF PACKAGES ARE THE MANUFACTURING OPTIONS. THE PART MAY BE SUPPLIED WITH OR WITHOUT ANY OF THE OPTIONS.
 DIMENSION DOES NOT INCLUDE MOLD FLASH. MOLD FLASH SHALL NOT EXCEED 0.006 (0.152mm) PER SIDE
 **DIMENSION DOES NOT INCLUDE INTERLEAD FLASH. INTERLEAD FLASH SHALL NOT EXCEED 0.010* (0.254mm) PER SIDE