

LMX9820 Bluetooth™ Serial Port Module

1.0 General Description

The National Semiconductor® LMX9820 Bluetooth™ Serial Port module is a highly integrated radio, baseband controller and memory device implemented on an LTCC (Low Temperature Co-fired Ceramic) substrate. All hardware and firmware is included to provide a complete solution from antenna through the complete lower and upper layers of the Bluetooth stack, up to the application including the Generic Access Profile (GAP), the Service Discovery Application Profile (SDAP), and the Serial Port Profile (SPP). The module includes a configurable service database to fulfil service requests for additional profiles on the host. The LMX9820 features a small form factor (10.1 x 14.0 x 1.9 mm) design; thus, solving many of the challenges associated with system integration. Moreover, the LMX9820 is pre-qualified as a Bluetooth Integrated Component. Conformance testing through the Bluetooth qualification program enables a short time to market after system integration by insuring a high probability of compliance and interoperability.

Based on National's CompactRISC™ 16-bit processor architecture and Digital Smart Radio technology, the LMX9820 is optimized to handle the data and link management processing requirements of a Bluetooth node.

The firmware supplied within this device offers a complete Bluetooth (v1.1) stack including profiles and command interface. This firmware features point-to-point and point-to-multipoint link management supporting data rates up to the theoretical maximum over RFSComm of 704 kbps. The internal memory supports up to three active Bluetooth links.

1.1 APPLICATIONS

- Personal Digital Assistants
- POS Terminals
- Data Logging Systems

2.0 Functional Block Diagram

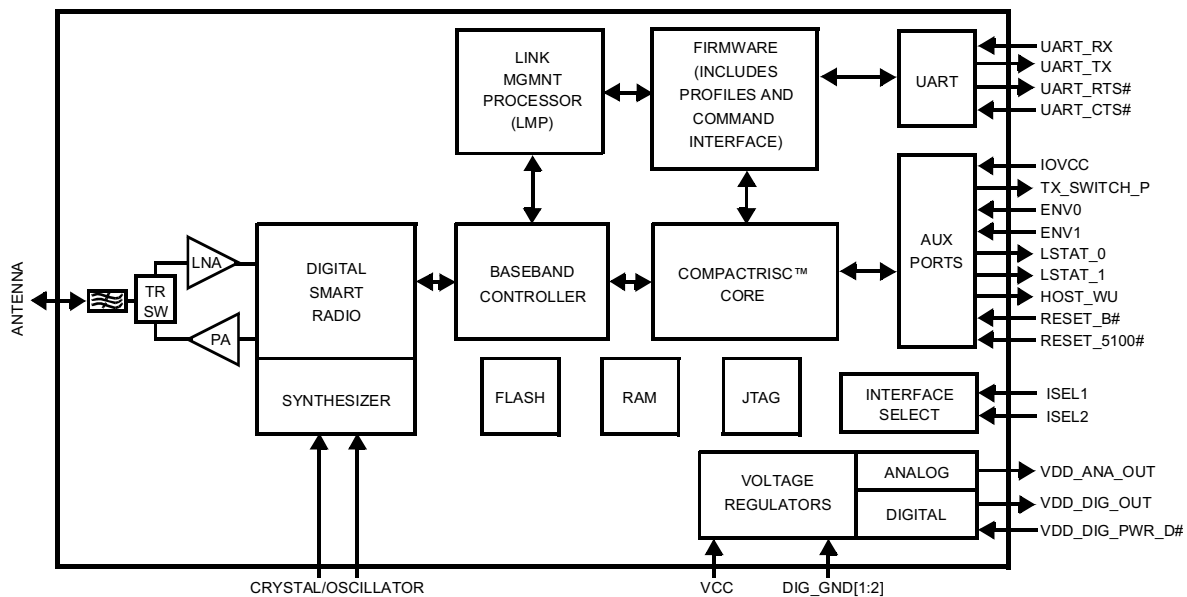

CompactRISC is a trademark of National Semiconductor Corporation.
Bluetooth is a trademark of Bluetooth SIG, Inc. and is used under license by National Semiconductor.

3.0 Features

- Bluetooth version 1.1 qualified
- Implemented in CMOS technology on LTCC substrate.
- Temperature Range: -40°C to +85°C

3.1 DIGITAL HARDWARE

- Baseband and Link Management processors
- CompactRISC Core
- Integrated Memory:
 - Flash
 - RAM
- UART Command/Data Port:
 - Support for up to 921.6k baud rate
- Auxiliary Host Interface Ports:
 - Link Status
 - Transceiver Status (Tx or Rx)
 - Operating Environment Control:
 - Default Bluetooth mode
 - In System Programming (ISP) mode
- Advanced Power Management (APM) features

3.2 FIRMWARE

- Complete Bluetooth Stack including:
 - Baseband and Link Manager
 - L2CAP, RFCOMM, SDP
 - Profiles:
 - GAP
 - SDAP
 - SPP
- Additional Profile support on Host for:
 - Dial Up Networking (DUN)
 - Facsimile Profile (FAX)
 - File Transfer Protocol (FTP)
 - Object Push Profile (OPP)
 - Synchronization Profile (SYNC)

- On-chip application including:
 - Command Interface:
 - Link setup and configuration (also Multipoint)
 - Configuration of the module
 - In system programming
 - Service database modifications
 - Default connections
 - UART Transparent mode
 - Different Operation modes:
 - Automatic mode
 - Command mode

3.3 DIGITAL SMART RADIO

- Accepts external clock or crystal input:
 - 12 MHz
 - 20 ppm cumulative clock error required for Bluetooth
- Synthesizer:
 - Integrated VCO and loop filter
 - Provides all clocking for radio and baseband functions
- Antenna Port (50 Ohms nominal impedance):
 - Embedded front-end filter for enhanced out of band performance
- Integrated transmit/receive switch (full duplex operation via antenna port)
- Embedded Balun
- Better than -77 dBm input sensitivity
- 0 dBm typical output power

3.4 PHYSICAL

- Compact size - 10.1mm x 14.0mm x 1.9mm
- Complete system interface provided in Land Grid Array on underside for surface mount assembly
- Metal shield included

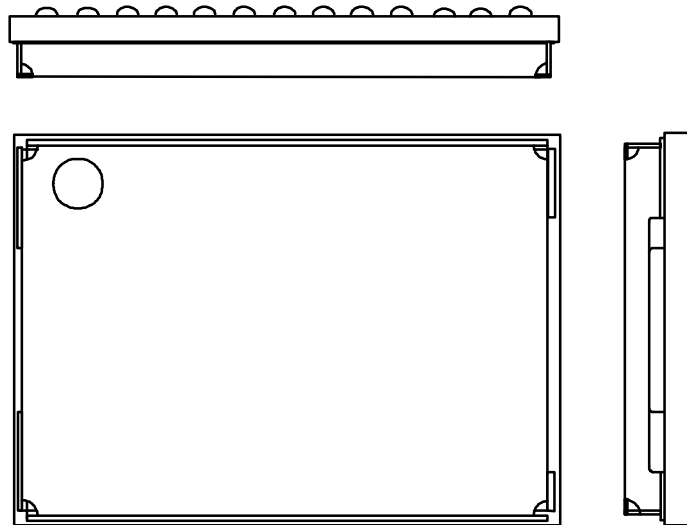
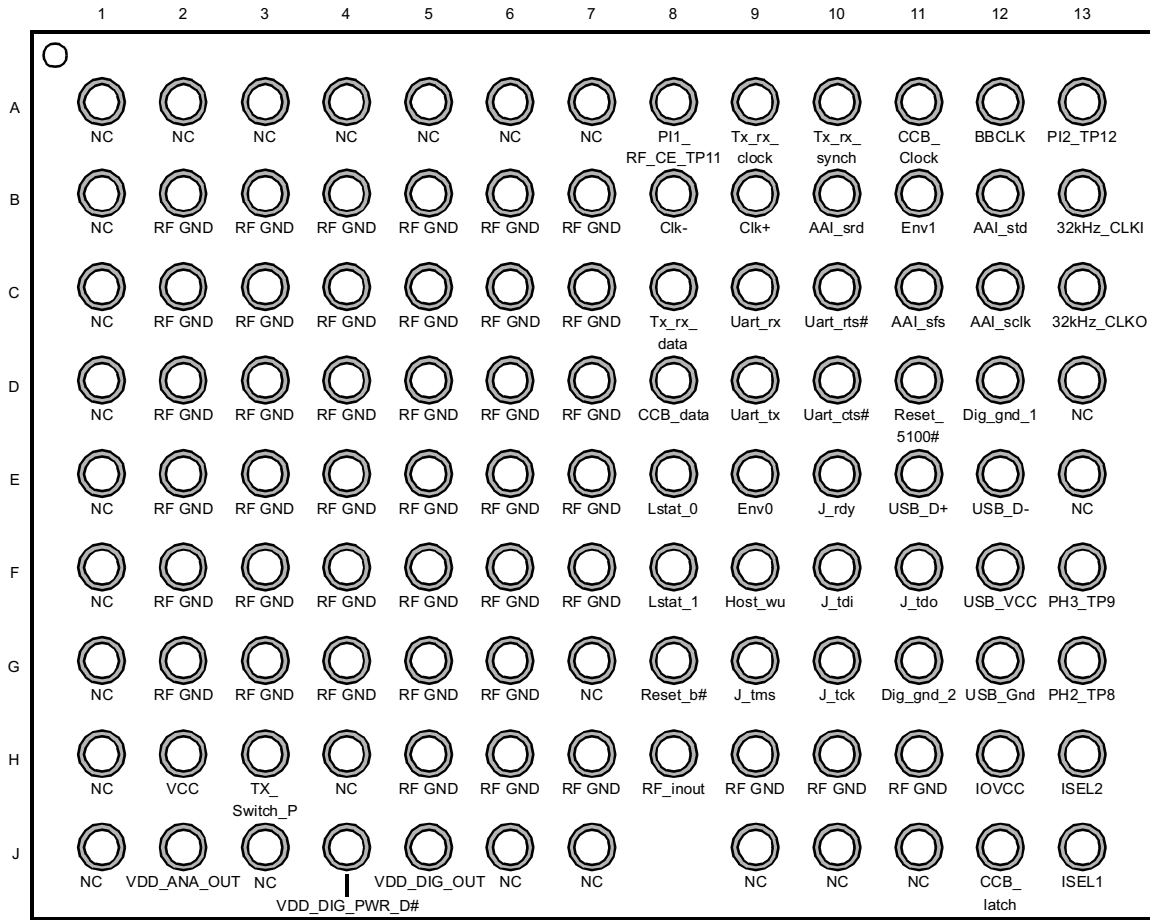

Figure 1. Physical Illustration

Table of Contents

1.0	General Description	1	9.0	System Power-Up Sequence	20
1.1	APPLICATIONS	1	10.0	Integrated Firmware	21
2.0	Functional Block Diagram	1	10.1	FEATURES	21
3.0	Features	2	10.1.1	Operation Modes	21
3.1	DIGITAL HARDWARE	2	10.1.2	Default Connections	21
3.2	FIRMWARE	2	10.1.3	Event Filter	21
3.3	DIGITAL SMART RADIO	2	10.1.4	Default Link Policy	21
3.4	PHYSICAL	2	11.0	Low Power Modes	23
4.0	Connection Diagram	4	11.1	POWER MODES	23
5.0	Pad Descriptions	5	11.2	ENABLING AND DISABLING UART TRANSPORT	23
6.0	Electrical Specifications	8	11.2.1	Hardware Wake up functionality	23
6.1	GENERAL SPECIFICATIONS	8	11.2.2	Disabling the UART transport layer	23
6.2	DC CHARACTERISTICS	9	11.2.3	LMX9820 enabling the UART interface	23
6.3	RF PERFORMANCE CHARACTERISTICS	10	11.2.4	Enabling the UART transport layer from the host	23
6.4	PERFORMANCE DATA (TYPICAL)	12	12.0	Command Interface	24
7.0	Functional Description	14	12.1	FRAMING	24
7.1	BASEBAND AND LINK MANAGEMENT PROCESSORS	14	12.1.1	Start and End Delimiter	24
7.1.1	Bluetooth Lower Link Controller	14	12.1.2	Packet Type ID	24
7.1.2	Bluetooth Upper Layer Stack	14	12.1.3	Opcode	24
7.1.3	Profile support	14	12.1.4	Data Length	24
7.1.4	Application with command interface	14	12.1.5	Checksum:	24
7.2	MEMORY	14	12.2	COMMAND SET OVERVIEW	25
7.3	CONTROL AND TRANSPORT PORT	15	13.0	Usage Scenarios	29
7.4	AUXILIARY PORTS	15	13.1	SCENARIO 1: POINT-TO-POINT CONNECTION	29
7.4.1	Reset_5100 and Reset_b	15	13.2	SCENARIO 2: AUTOMATIC POINT-TO-POINT CONNECTION	30
7.4.2	Operating Environment Pads (Env0 and Env1)	15	13.3	SCENARIO 3: POINT-TO-MULTIPOINT CONNEC- TION	31
7.4.3	Interface Select Inputs (ISEL1, ISEL2)	15	14.0	Application Information	32
7.4.4	Module and Link Status Outputs	15	14.1	MATCHING NETWORK	32
8.0	Digital Smart Radio	16	14.2	FILTERED POWER SUPPLY	32
8.1	RADIO RECEIVER	16	14.3	HOST INTERFACE	32
8.2	LOW NOISE AMPLIFIER (LNA)	16	14.4	CLOCK INPUT	32
8.3	RX MIXER	16	14.5	SCHEMATIC AND LAYOUT EXAMPLES	32
8.4	CHANNEL SELECT FILTER	16	15.0	Soldering	36
8.5	LIMITER	16	16.0	Datasheet Revision History	38
8.6	FM DISCRIMINATOR	16	17.0	Physical Dimensions	40
8.7	RECEIVE SIGNAL STRENGTH INDICATOR (RSSI)	16			
8.8	RADIO TRANSMITTER	16			
8.9	MODULATOR	16			
8.10	TRANSMIT FREQUENCY OUTPUT	16			
8.11	FREQUENCY SYNTHESIZERS	16			
8.12	CRYSTAL CIRCUIT	16			
8.13	EXTERNAL CRYSTAL OSCILLATORS	16			
8.13.1	Crystal	16			
8.13.2	TCXO (Temperature Compensated Crystal Oscillator)	19			

4.0 Connection Diagram



X-Ray (Top View)

Figure 2. Connection Diagram LMX9820

Table 1. Order Information

Order Number	Shipment Method
LMX9820SB	Tray
LMX9820SBX	Tape & Reel

5.0 Pad Descriptions

Table 2. System Interface Signals

Pad Name	Pad Location	Direction	Description
Clk-	B8	Input	Xtal g or Negative Clock Input. Typically connected along with XTAL_D to an external surface mount AT cut crystal. Can also be configured as a frequency input when using an external crystal oscillator. When configured as a frequency input, typically connected to Ground with a 10 pF capacitor.
Clk+	B9	Input	Xtal d or Positive Clock Input. Typically connected along with XTAL_G to an external surface mount AT cut crystal. Can also be configured as a frequency input when using an external crystal oscillator. When configured as a frequency input, is typically connected to an external Temperature Compensated Crystal Oscillator (TCXO) through an Alternating Current (AC) coupling capacitor.
32kHz_CLKI	B13	Input	32 kHz Clock input. Not supported. Place pad and do not connect to VCC or Ground.
32kHz_CLKO	C13	Output	32 kHz Clock Output. Not supported. Place pad and do not connect to VCC or Ground.
RF_inout	H8	Input/Output	RF Antenna Port. 50Ω nominal impedance. Typically connected to an antenna through a 6.8pF capacitor.
ISEL2	H13	Input	Module Interface Select Input Bit 1.
ISEL1	J13	Input	Module Interface Select Input Bit 0.

Table 3. USB Interface Signals (Not supported by lmx9820 firmware)

Pad Name	Pad Location	Direction	Description
USB_VCC	F12	Input	USB Transceiver Power Supply + ¹
USB_D+	E11	Input/Output	USB Data Positive ¹
USB_D-	E12	Input/Output	USB Data Negative ¹
USB_Gnd	G12	Input	USB Transceiver Ground ¹

1. Treat as No Connect, Pad required for mechanical stability.

Table 4. UART Interface Signals

Pad Name	Pad Location	Direction	Description
Uart_tx	D9	Output	UART Host Control Interface Transport, Transmit Data.
Uart_rx	C9	Input	UART Host Control Interface Transport, Receive Data.
Uart_rts#	C10	Output	UART Host Control Interface Transport, Request to Send.
Uart_cts#	D10	Input	UART Host Control Interface Transport, Clear to Send.

5.0 Pad Descriptions (Continued)

Table 5. Auxiliary Ports Interface Signals

Pad Name	Pad Location	Direction	Description
IOVCC	H12	Input	2.85V to 3.6V Logic Threshold Program Input.
Reset_b#	G8	Input	Reset Input for Smart Radio. Normally connected to Reset_5100.
Reset_5100#	D11	Input	Reset for Baseband and Link Management Processors. Active low.
Lstat_0	E8	Output	Link Status Bit 0.
Lstat_1	F8	Output	Link Status Bit 1.
Host_wu	F9	Output	Host Wakeup
Env0	E9	Input	Module Operating Environment Bit 0.
Env1	B11	Input	Module Operating Environment Bit 1.
TX_Switch_P	H3	Output	Transceiver Status, 0 = Receive; 1 = Transmit.

Table 6. Audio Port Interface Signals (not supported by LMX9820 Firmware)

Pad Name	Pad Location	Direction	Description
AAI_srd	B10	Input	Advanced Audio Interface Receive Data Input. ¹
AAI_std	B12	Output	Advanced Audio Interface Transmit Data Output. ¹
AAI_sfs	C11	Input/Output	Advanced Audio Interface Frame Synchronization. ¹
AAI_sclk	C12	Input/Output	Advanced Audio Interface Clock. ¹

1. Treat as No Connect, Pad required for mechanical stability.

Table 7. Test Interface Signals

Pad Name	Pad Location	Direction	Description
J_rdy	E10	Output	JTAG Ready. ¹
J_tdi	F10	Input	JTAG Test Data. ¹
J_tdo	F11	Input/Output	JTAG Test Data. ¹
J_tms	G9	Input/Output	JTAG Test Mode Select. ¹
J_tck	G10	Input	JTAG Test Clock. ¹
PI1_RFCE_TP1 1	A8	Testpin	Module Test Point. ¹
PI2_TP12	A13	Testpin	Module Test Point. ¹
Tx_rx_clock	A9	Testpin	Module Test Point. ¹
Tx_rx_data	C8	Testpin	Module Test Point. ¹
Tx_rx_synch	A10	Testpin	Module Test Point. ¹
CCB_Clock	A11	Testpin	Module Test Point. ¹
CCB_data	D8	Testpin	Module Test Point. ¹
CCB_latch	J12	Testpin	Module Test Point. ¹
BBCLK	A12	Testpin	Module Test Point. ¹

5.0 Pad Descriptions (Continued)

Table 7. Test Interface Signals (Continued)

Pad Name	Pad Location	Direction	Description
PH3_TP9	F13	Testpin	Module Test Point. ¹
PH2_TP8	G13	Testpin	Module Test Point. ¹

1. Treat as No Connect, Pad required for mechanical stability.

Table 8. Power, Ground, and No Connect Signals

Pad Name	Pad Location	Direction	Description
NC	A1, A2, A3, A4, A5, A6, A7, B1, C1, D1, D13, E1, E13, F1, G1, G7, H1, H4, J1, J3, J6, J7, J9, J10, J11	not connected	No Connect. Must have pad for mechanical stability.
RF GND ¹	B2, B3, B4, B5, B6, B7, C2, C3, C4, C5, C6, C7, D2, D3, D4, D5, D6, D7, E2, E3, E4, E5, E6, E7, F2, F3, F4, F5, F6, F7, G2, G3, G4, G5, G6, H5, H6, H7, H9, H10, H11	Input	Radio System Ground. Must be connected to RF Ground plane. Thermal relief required for proper soldering.
Dig_gnd_1 ¹	D12	Input	Digital Ground.
Dig_gnd_2 ¹	G11	Input	Digital Ground.
VCC	H2	Input	2.85V to 3.6V Input for the Internal Power Supply Regulators.
VDD_ANA_OUT	J2	Output	Voltage Regulator Output/Power Supply for Analog Circuitry. If not used, place pad and do not connect to VCC or Ground.
VDD_DIG_OUT	J5	Output	Voltage Regulator Output/Power Supply for Digital Circuitry. If not used, place pad and do not connect to VCC or Ground.
VDD_DIG_PWR_D#	J4	Input	Power Down for the Internal Power Supply Regulator for the Digital Circuitry. Place pad and do not connect to VCC or Ground.

1. Connect RF GND, Dig_gnd_1, and Dig_gnd_2 to single Ground plane.

6.0 Electrical Specifications

6.1 GENERAL SPECIFICATIONS

Absolute Maximum Ratings (see Table 9) indicate limits beyond which damage to the device may occur. Operating Ratings (see Table 10) indicate conditions for which the device is intended to be functional.

This device is a high performance RF integrated circuit and is ESD sensitive. Handling and assembly of this device should be performed at ESD free workstations.

The following conditions are true unless otherwise stated in the tables below:

- $T_A = -40^{\circ}\text{C}$ to $+85^{\circ}\text{C}$
- $V_{CC} = 3.3\text{V}$
- RF system performance specifications are guaranteed on National Semiconductor Austin Board rev1.0b reference design platform.

Table 9. Absolute Maximum Ratings

Symbol	Parameter	Min	Max	Unit
VCC	Core Logic Power Supply Voltage	2.25	3.6	V
IOVCC	I/O Power Supply Voltage	2.25	3.6	V
USB_VCC ¹	USB Power Supply Voltage	2.97	3.63	V
V _I	Voltage on any pad with GND = 0V	-0.5	VCC + 0.5	V
PinRF	RF Input Power		+15	dBm
T _S	Storage Temperature Range	-65	+150	°C
T _L	Lead Temperature (solder 4 sec)		+260	°C
ESD-HBM	ESD - Human Body Model		2000	V
ESD-MM	ESD - Machine Model		200	V

1. USB Interface not supported by LMX9820 firmware. Treat as no connect, place pad for mechanical stability.

Table 10. Recommended Operating Conditions¹

Symbol	Parameter	Min	Typ ²	Max	Unit
VCC	Module Power Supply Voltage	2.85	3.3	3.6	V
IOVCC	I/O Power Supply Voltage	2.85	3.3	3.6	V
USB_VCC ³	USB Power Supply Voltage	2.97	3.3	3.63	V
t _R	Module Power Supply Rise Time			50	ms
T _O	Operating Temperature Range	-40		+85	°C
HUM _{OP}	Humidity (operating, across operating temperature range)	10		90	%
HUM _{NONOP}	Humidity (non-operating, 38.7°C web bulb temperature)	5		95	%

1. Maximum voltage difference allowed between VCC and IOVCC is 500 mV.
2. Typical operating conditions are at 3.3V operating voltage and 25°C ambient temperature.
3. USB Interface not supported by LMX9820 firmware. Treat as no connect, place pad for mechanical stability.

Table 11. Power Supply Electrical Specifications: Analog and Digital LDOs

Symbol	Parameter	Min	Typ ¹	Max	Unit
VDD_ANA_OUT	Analog Voltage Output Range ²	2.20	2.54	2.75	V
VDD_DIG_OUT	Digital Voltage Output Range ³	2.40	2.60	2.75	V

1. Typical operating conditions are at 3.3V operating voltage and 25°C ambient temperature.
2. Set in factory at 2.5V nominal output.
3. Set in factory at 2.6V nominal output.

6.0 Electrical Specifications (Continued)

NOTE: The voltage regulators are optimized for the internal operation of the LMX9820. As any noise or coupling into those can have influence on the radio performance, it is

highly recommended to have no additional load on those outputs.

Table 12. Power Supply Requirements^{1,2,3}

Symbol	Parameter	Min	Typ	Max	Unit
I _{CC-TX}	Power supply current for continuous transmit		56	80	mA
I _{CC-RX}	Power supply current for continuous receive		62	78	mA
I _{RXSL}	Receive Data in SPP Link, Slave ⁴		33		mA
I _{RXM}	Receive Data in SPP Link, Master ⁴		27		mA
I _{SnM}	Sniff Mode, Sniffintervall 1 second ⁴		12.3		mA
I _{SC-TLDIS}	Scanning, No Active Link, TL Disabled ⁴		7		mA
I _{Idle}	Idle, Scanning Disabled, TL Disabled ⁴		5.7		mA

1. Power supply requirements based on Class II output power.
2. VCC = 3.0V, IOVCC = 3.3V, Ambient Temperature = +25 °C.
3. Based on UART Baudrate 115.2kbit/s.
4. Average values

6.2 DC CHARACTERISTICS

Table 13. Digital DC Characteristics

Symbol	Parameter	Condition	Min	Max	Units
VCC	Core Logic Supply Voltage		2.85	3.6	V
IOVCC	IO Supply Voltage		2.85	3.6	V
V _{IH}	Logical 1 Input Voltage		0.7*IOVCC	IOVCC + 0.5	V
V _{IL}	Logical 0 Input Voltage		-0.5	0.2*IOVCC	V
V _{XL2} ¹	32.768kHz Logical 0 Input Voltage	External 32.768kHz clock	-0.5	0.3*IOVCC	V
V _{XH2} ¹	32.768kHz Logical 1 Input Voltage	External 32.768kHz clock	0.7*IOVCC	IOVCC + 0.5	V
V _{HYS}	Hysteresis Loop Width ²		0.1*IOVCC		V
I _{OH}	Logical 1 Output Current	V _{OH} = 1.8V, IOVCC = 2.25V	-1.6		mA
I _{OL}	Logical 0 Output Current	V _{OL} = 0.45V, IOVCC = 2.25V	1.6		mA
I _{OHW}	Weak Pull-up Current	V _{OH} = 1.8V, IOVCC = 2.25V	-10		μA
I _{IH}	High-level Input Current	V _{IH} = IOVCC = 2.85V	-1.0	1.0	μA
I _{IL} ³	Low-level Input Current	V _{IL} = 0	-1.0	1.0	μA
I _L	High Impedance Input Leakage Current	0V ≤ V _{IN} ≤ IOVCC	-2.0	2.0	μA
I _{O(off)}	Output Leakage Current (I/O pins in input mode)	0V ≤ V _{OUT} ≤ VCC	-2.0	2.0	μA

1. Not supported, please place pad and leave unconnected.
2. Guaranteed by design.
3. Limit for I_{IL} for the pins Reset_b#, PI1_RFCE_TP & VDD_DIG_PWR_D# is +/-3uA.

6.0 Electrical Specifications (Continued)

6.3 RF PERFORMANCE CHARACTERISTICS

In the performance characteristics tables the following applies:

- All tests performed are based on Bluetooth Test Specification rev 0.91.

- All tests are measured at antenna port unless otherwise specified
- $T_A = -40^{\circ}\text{C}$ to $+85^{\circ}\text{C}$
- VCC = 3.3V unless otherwise specified
- RF system performance specifications are guaranteed on National Semiconductor Austin Board rev1.0b reference design platform.

Table 14. Receiver Performance Characteristics

Symbol	Parameter	Condition	Min	Typ ¹	Max	Unit
RX _{sense} ²	Receive Sensitivity	BER < 0.001	2.402 GHz	-77	-74	dBm
			2.441 GHz	-77	-74	dBm
			2.480 GHz	-77	-74	dBm
PinRF	Maximum Input Level		-20	0		dBm
C/I _{CCI}	Carrier to Interferer Ratio in the Presence of Co-channel Interferer	P _{inRF} = -60 dBm, BER < 0.001		9	11	dB
C/I _{ACI}	Carrier to Interferer Ratio in the Presence of Adjacent Channel Interferer	$\Delta F_{ACI} = \pm 1$ MHz, P _{inRF} = -60 dBm, BER < 0.001		-3	0	dB
		$\Delta F_{ACI} = + 2$ MHz, P _{inRF} = -60 dBm, BER < 0.001		-42	-30	dB
		$\Delta F_{ACI} = + 3$ MHz, P _{inRF} = -67 dBm, BER < 0.001		-46	-40	dB
C/I _{IMAGE}	Image Frequency Interference	$\Delta F = - 2$ MHz, P _{inRF} = -67 dBm, BER < 0.001		-20	-9	dB
C/I _{IMAGE - 1MHz}	Image Frequency Interference	$\Delta f = - 3$ MHz, P _{inRF} = -67 dBm, BER < 0.001		-32	-20	dB
IMP ³	Intermodulation Interference Performance	F ₁ = + 3 MHz, F ₂ = + 6 MHz, P _{inRF} = -64 dBm	-39	-31		dBm
Z _{RFIN} ⁴	Input Impedance of RF Port (RF_inout)	Single input impedance F _{in} = 2.5 GHz		50		Ω
Return Loss ⁵	Return Loss				-8	dB
OOB	Out Of Band Blocking Performance	P _{inRF} = -10 dBm, 30 MHz < F _{CWI} < 2 GHz, BER < 0.00	-10			dBm
		P _{inRF} = -27 dBm, 2000 MHz < F _{CWI} < 2399 MHz, BER < 0.001	-27			dBm
OOB	Out Of Band Blocking Performance (Continued)	P _{inRF} = -27 dBm, 2498 MHz < F _{CWI} < 3000 MHz, BER < 0.001	-27			dBm
		P _{inRF} = -10 dBm, 3000 MHz < F _{CWI} < 12.75 GHz, BER < 0.001	-10			dBm

- Typical operating conditions are at 3.3V operating voltage and 25°C ambient temperature.
- The receiver sensitivity is measured at the device interface.
- The f₀ = -64dBm Bluetooth modulated signal, f₁ = -39dBm sine wave, f₂ = -39dBm Bluetooth modulated signal, f₀ = 2f₁ - f₂, and |f₂ - f₁| = n * 1MHz, where n is 3, 4 or 5. For the typical case, n = 3.
- Reference Smith Chart Figure 8 on page 13.
- Reference chart Figure 9 on page 14.

6.0 Electrical Specifications (Continued)

Table 15. Transmitter Performance Characteristics

Symbol	Parameter	Condition	Min	Typ ¹	Max	Unit
P _{OUTRF} ²	Transmit Output Power	2.402 GHz	-3	+1	+4	dBm
		2.441 GHz	-3	+1	+4	dBm
		2.480 GHz	-3	+1	+4	dBm
Power Density	Power Density		-4	1	2	dBm
MOD ΔF _{1AVG}	Modulation Characteristics	Data = 00001111	140	165	175	kHz
MOD ΔF _{2MAX} ³	Modulation Characteristics	Data = 10101010	115	125		kHz
ΔF _{2AVG} /ΔF _{1AVG} ⁴	Modulation Characteristics		0.8			
ACP ⁵	Adjacent Channel Power (In-band Spurious)	± 500 kHz			-20	dBc
		M - N = 2	-50	-48	-20	dBm
		M - N ≥ 3	-53	-51	-40	dBm
P _{OUT2*f₀} ⁶	PA 2 nd Harmonic Suppression	Maximum gain setting: f ₀ = 2402 MHz, P _{out} = 4804 MHz		-77		dB
P _{OUT3*f₀} ³	PA 3 rd Harmonic Suppression	Maximum gain setting: f ₀ = 2402 MHz, P _{out} = 7206 MHz		-98		dB
Z _{RFOUT} ⁷	RF Output Impedance/In-put Impedance of RF Port (RF_inout)	P _{out} @ 2.5 GHz		50		Ω
Return Loss ⁸	Return Loss				-8	dB

1. Typical operating conditions are at 3.3V operating voltage and 25°C ambient temperature.
2. The output power is measured at the antenna port, including all front end losses for balun, TX/RX switch and filter.
3. ΔF_{2max} ≥ 115 kHz for at least 99.9% of all Δf_{2max}.
4. Modulation index set between 0.28 and 0.35.
5. Not tested in production.
6. Out-of-Band spurs only exist at 2nd and 3rd harmonics of the CW frequency for each channel. Performance of the radio is significantly better than BT 1.1 specification.
7. Reference Smith chart Figure 8 on page 13.
8. Reference chart Figure 9 on page 14.

Table 16. Synthesizer Performance Characteristics¹

Symbol	Parameter	Condition	Min	Typ	Max	Unit
f _{VCO}	VCO Frequency Range		2402		2480	MHz
t _{LOCK}	Lock Time	f ₀ ± 20 kHz		120		μs
Δf _{0offset}	Initial Carrier Frequency Tolerance	During preamble	-75	0	75	kHz
Δf _{0drift}	Initial Carrier Frequency Drift	DH1 data packet	-25	0	25	kHz
		DH3 data packet	-40	0	40	kHz
		DH5 data packet	-40	0	40	kHz
		Drift Rate	-20	0	20	kHz/50μs
t _{D-Tx}	Transmitter Delay Time	From Tx data to antenna		4		μs

1. Frequency accuracy dependent on crystal or oscillator chosen. Crystal/oscillator must have cumulative accuracy specifications of not more than ±20 ppm to meet the Bluetooth specification.

6.0 Electrical Specifications (Continued)

Table 17. Crystal/Oscillator Performance Characteristics

Symbol	Parameter	Condition	Min	Typ	Max	Unit
f_{OSC}	Crystal Oscillator Frequency			12		MHz
f_{ACC}^1	Frequency Accuracy	Cumulative over operating temperature range	-20		+20	ppm
t_{OSC-ON}	Oscillator Turn-On Time	VCC applied, $f_{OSC} = 12$ MHz, $C_{ext} = 0.1 \mu F$, settled to within f_{ACC}		4		ms
V_{OSC}	Oscillator Input Voltage	External XO input	0.6		2.0	Vpp
ESR	Equivalent Series Resistance			50	100	Ω
D_{CYCLE}	Duty Cycle		49		51	%
P_{NOISE}	Phase Noise	100Hz			-105	dBc/Hz
		1000Hz			-125	dBc/Hz
BBCLK	Baseband Clock Output Frequency			12		MHz

1. Frequency accuracy dependent on crystal or oscillator chosen. Crystal/oscillator must have cumulative accuracy specifications of ± 15 ppm to provide margin for frequency drift with ageing and temperature.

6.4 PERFORMANCE DATA (TYPICAL)

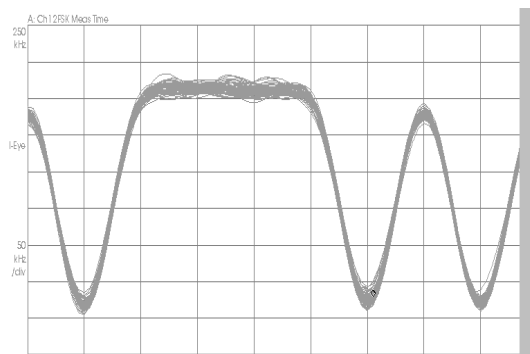

Figure 3. Modulation

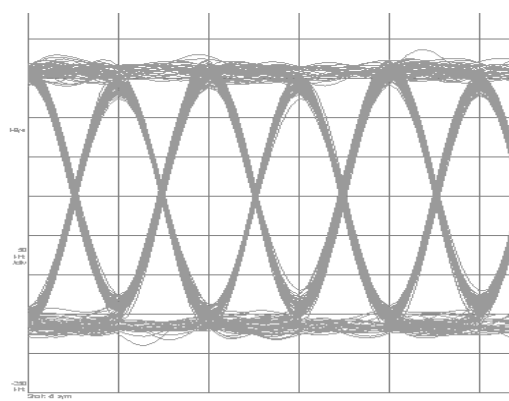

Figure 5. Corresponding Eye Diagram

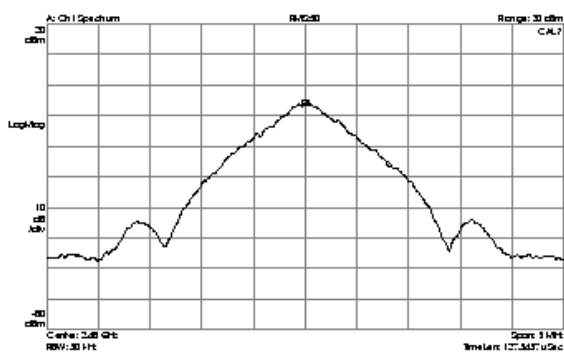

Figure 4. Transmit Spectrum

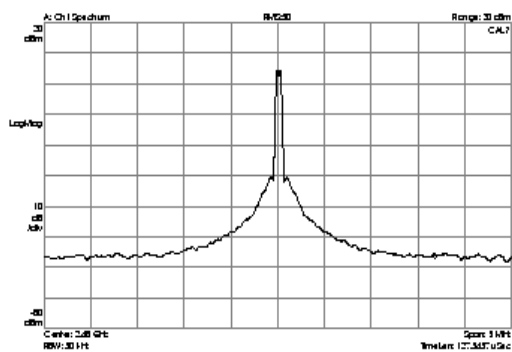

Figure 6. Synthesizer Phase Noise

6.0 Electrical Specifications (Continued)

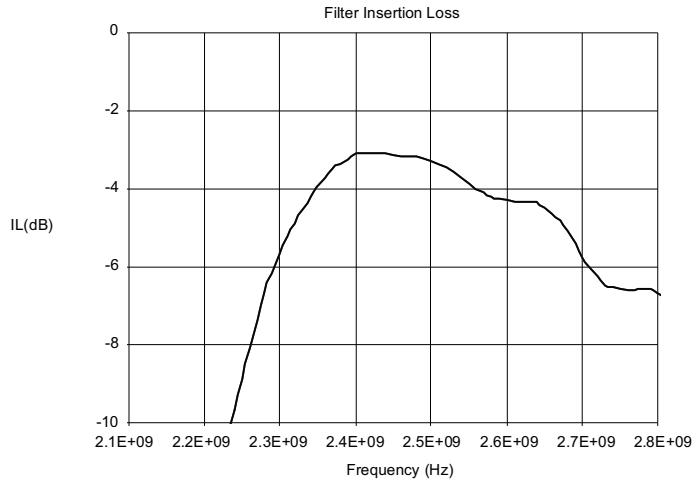

Figure 7. Front-End Bandpass Filter Response

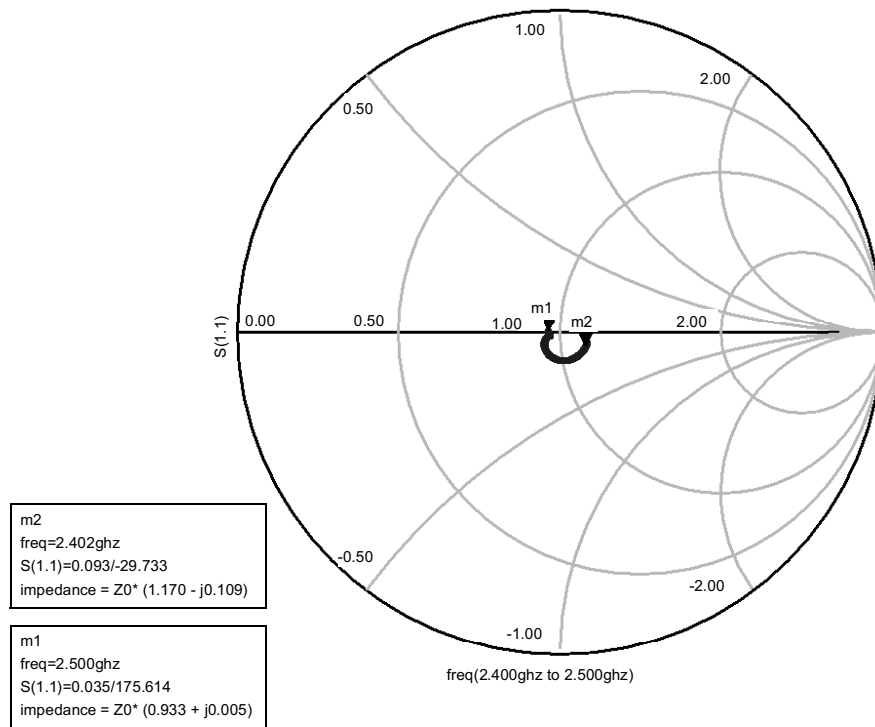

Figure 8. TX and RX Pin 50Ω Impedance Characteristics

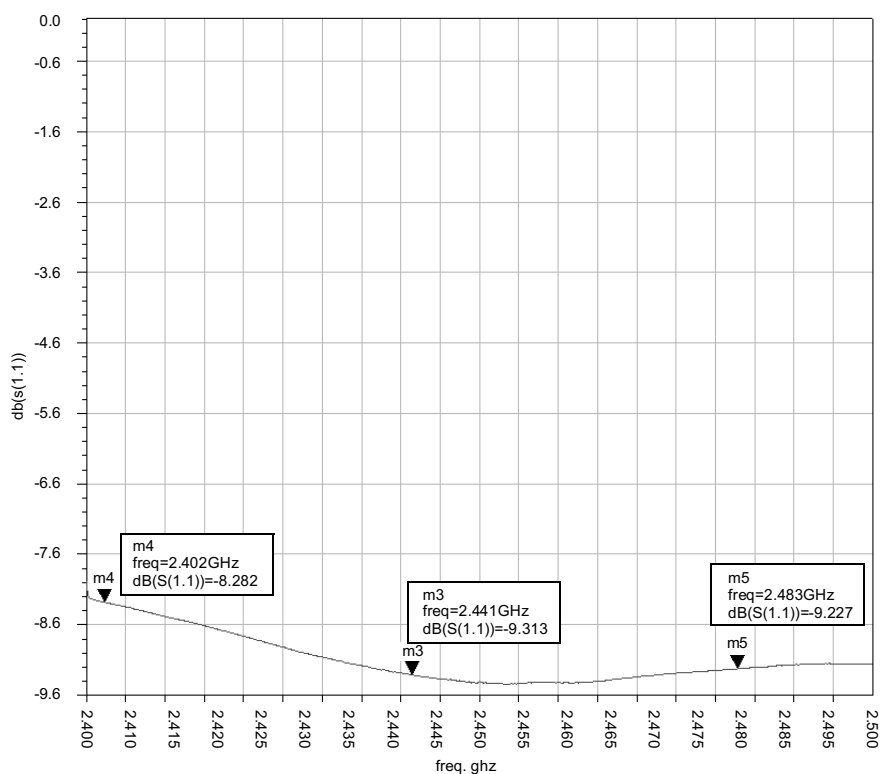

Figure 9. Transceiver Return Loss

7.0 Functional Description

7.1 BASEBAND AND LINK MANAGEMENT PROCESSORS

Baseband and Lower Link control functions are implemented using a combination of National Semiconductor's CompactRISC 16-bit processor and the Bluetooth Lower Link Controller. These processors operate from integrated Flash memory and RAM and execute on-board firmware implementing all Bluetooth functions.

7.1.1 Bluetooth Lower Link Controller

The integrated Bluetooth Lower Link Controller (LLC) complies with the Bluetooth Specification version 1.1 and implements the following functions:

- Support for 1, 3, and 5 slot packet types
- 79 Channel hop frequency generation circuitry
- Fast frequency hopping at 1600 hops per second
- Power management control
- Access code correlation and slot timing recovery

7.1.2 Bluetooth Upper Layer Stack

The integrated upper layer stack is prequalified and includes the following protocol layers:

- L2CAP
- RFCOMM
- SDP

7.1.3 Profile support

The on-chip application of the LMX9820 allows full stand-alone operation, without any Bluetooth protocol layer necessary outside the module. It supports the Generic Access Profile (GAP), the Service Discovery Application Profile (SDAP), and the Serial Port Profile (SPP).

The on-chip profiles can be used as interfaces to additional profiles executed on the host. The LMX9820 includes a configurable service database to answer requests with the profiles supported.

7.1.4 Application with command interface

The module supports automatic slave operation eliminating the need for an external control unit. The implemented transparent option enables the chip to handle incoming data raw, without the need for packaging in a special format. The device uses a fixed pin to block unallowed connections.

Acting as master, the application offers a simple but versatile command interface for standard Bluetooth operation like inquiry, service discovery, or serial port connection. The firmware supports up to three slaves. Default Link Policy settings and a specific master mode allow optimized configuration for the application specific requirements. See also Section "Integrated Firmware" on page 21.

7.2 MEMORY

The LMX9820 includes 256kB of programmable Flash memory that can be used for code and constant data. It allows single cycle read access from the CPU. In addition

to storing all algorithms and firmware, the on-board Flash also contains the IEEE 802 compliant Media Access Controller (MAC) address (BDADDR). The firmware and the BDADDR are programmed by National Semiconductor or can be programmed by the customer either before assembly into the host system or in system. Module firmware can be updated as well during manufacturing or by the consumer using the ISP capabilities of the LMX9820. The LMX9820 firmware uses the internal RAM for buffers and program variables.

7.3 CONTROL AND TRANSPORT PORT

The LMX9820 provides one Universal Asynchronous Receiver Transmitter (UART). It supports 8-bit data formats with or without parity and one or two stop bits. The baud rate is generated by hardware that is programmed at boot time. Alternatively, the speed and configuration settings can be read out of internal memory settings. The UART can operate at baud rates of 2.4k, 4.8k, 7.2k, 9.6k, 19.2k, 38.4k, 57.6k, 115.2k, 230.4k, 460.8k and 921.6k. It implements flow control logic (RTS, CTS) to provide hardware handshaking capability. The UART offers wakeup from the power save modes via the multi-input wakeup module. UART logic thresholds are set via the IOVCC pin.

7.4 AUXILIARY PORTS

7.4.1 Reset_5100 and Reset_b

Reset_5100 and Reset_b are active low reset inputs for the baseband controller and digital smart radio portions of the LMX9820, respectively. These pins are normally tied together and are connected to the host system so that the host can initialize the LMX9820 by asserting the reset inputs. Upon removal, the status of the module operating environment (Env) pads are sampled and the LMX9820 enters the corresponding operational mode.

7.4.2 Operating Environment Pads (Env0 and Env1)

The module provides two operating environments (see Table 18) depending on the state of the Env pads after the removal of the reset inputs. At power up of the module, Env0 and Env1 are checked to determine which operating environment straps are selected and operating.

The ISP mode allows end-of-line or field programming of the LMX9820 Flash memory by starting the baseband controller from the boot block of memory.

Table 18. Operating Environments

Operating Environment	Env1 (Pad B11)	Env0 (Pad E9)
ISP Mode	1	0
Run (Normal) Mode (Default)	1	1

7.4.3 Interface Select Inputs (ISEL1, ISEL2)

The interface selection pads are used for setting the UART speed and settings. As ISEL1 and ISEL2 are set by internal weak-pull-ups, the default baudrate is 921.6kbit/s. The settings for Stopbits, Startbit and Parity are stored as internal NVS parameter. If a baudrate different to the listed needs to be used, ISEL 1 and ISEL2 have to be set to 0. This forces the device to get also the UART speed from the parameter table. The default baudrate value set in NVS is

9.6kbit/s. Default configuration in NVS is 1 Stopbit, 1 Startbit and No parity.

Table 19 provides the ISEL1 and ISEL2 selection settings.

Table 19. UART Speed Selection

ISEL1 (Pad J13)	ISEL2 (Pad H13)	Interface Speed (baud)	UART Settings
1	1	921.6k	Check NVS
0	1	115.2k	Check NVS
1	0	9.6k	1Stop, 1Start, No Parity
0	0	Check NVS	Check NVS

7.4.4 Module and Link Status Outputs

The LMX9820 provides signals that the host can use to determine the real-time status of the radio link. The TX_Switch_P signal (pad H3) is a real-time indication of the current configuration (direction) of the transceiver. The link status lines (Lstat_0 and Lstat_1, pads E8 and F8, respectively) are GPIO lines controlled by the LMX9820 firmware. The Host Wakeup line (Host_wu, pad F9) is implemented using GPIO and firmware. It is used to bring the host processor out of Sleep mode when link activity calls for host processing. Host_wu can also be used by the host to check if link activity is present. If Host_wu is active, then link activity is present and the host loses network awareness if the operating system continues to allow the host processor to enter the Sleep mode. Table 20 presents the definitions of the various module and link status outputs.

Table 20. Module / Link Status Definitions

Lstat_0 (Pad E8)	Lstat_1 (Pad F8)	TX_Switch_P (Pad H3)	Host_wu (Pad F9)	Mode
x	1	x	x	At least 1 SPP link established
x	0	x	x	No SPP link
x	x	1	x	Transceiver = Transmit
x	x	0	x	Transceiver = Receive
x	x	x	0	Host can Sleep
x	x	x	1	Wakeup host/host shouldn't Sleep

8.0 Digital Smart Radio

The LMX9820 Digital Smart Radio includes a high performance, monolithic, radio transceiver optimized for Bluetooth communications systems.

The radio transceiver is a highly integrated design and includes the Low Noise Amplifier (LNA), mixer, on-chip filters, 2.5 GHz $\Delta\Sigma$ PLL, voltage controlled oscillator, Power Amplifier (PA) driver, and modem functions. Digital modulation and demodulation techniques are utilized for a robust manufacturable design. Power management includes control over individual chip functions and internal voltage regulation for optimum performance.

8.1 RADIO RECEIVER

The signal path of the RX architecture contains an internal LNA and quadrature RF downconverting mixer at 2.5 GHz. A low Intermediate Frequency (IF) receiver provides high performance at low cost and low current consumption. The IF demodulator is implemented digitally in combination with a limiting amplifier.

8.2 LOW NOISE AMPLIFIER (LNA)

The on-board LNA is a single-ended structure designed with a 50Ω input impedance for simple capacitive matching. The LNA is closely integrated with the mixer providing low noise and good immunity from blocking signals.

8.3 RX MIXER

The receive mixer is an image reject ring diode type mixer. An internal low noise gain block is incorporated prior to the mixer to achieve extremely low noise performance. A differential IF output improves noise immunity while maintaining a high intercept point.

8.4 CHANNEL SELECT FILTER

The IF circuitry is followed by an integrated complex active bandpass filter that provides the required channel selectivity and image rejection. The I and Q outputs of the filter are then converted to the digital domain using a limiter, discriminator, and A/D converter.

8.5 LIMITER

The limiter circuit consists of I and Q limiting amplifiers that provide the remaining gain in the receiver such that an acceptable signal level exists at the frequency modulation (FM) discriminator. Limiting amplification of the downconverted wanted signal minimizes the input range requirements of the A/D converter.

8.6 FM DISCRIMINATOR

The limited signal is translated to digital format by using an analog Frequency Shift Keying (FSK) demodulator and A/D converter. The A/D converter extracts the RX signal at a sample rate of 72.0 MHz.

8.7 RECEIVE SIGNAL STRENGTH INDICATOR (RSSI)

The receive signal strength indicator (RSSI) signal is derived from the input level to the limiter and covers a range low detector level = -59dBm and high detector level = -38dBm. The information is typically fed back to the baseband controller via the serial interface.

8.8 RADIO TRANSMITTER

The signal path of the TX architecture contains an internal modulator for 1 Mb/s GFSK (Gaussian Frequency Shift Keying) modulation of the 2.5 GHz VCO. Closed loop $\Delta\Sigma$ modulation is chosen since it is the most low power solution. The integrated pre-amplifier provides output levels sufficient for Class 2 Bluetooth operation.

8.9 MODULATOR

An internal digital Gaussian filter provides the FSK modulation waveform. A modulation input to the completely integrated 2.5 GHz $\Delta\Sigma$ PLL provides a consistent modulation deviation. This eliminates the risks of open loop modulation such as frequency drift and frequency offset.

8.10 TRANSMIT FREQUENCY OUTPUT

The transmit RF output is differential, and is connected to the antenna through an integrated passive balun.

8.11 FREQUENCY SYNTHESIZERS

The 2.4 to 2.5GHz RF range is provided by an on-chip voltage controlled oscillator (VCO). A programmable 2.5 GHz $\Delta\Sigma$ PLL selects the channel frequency. An internal crystal oscillator can be configured with 12MHz crystal, or for TCXO frequency input. Internal dividers provide internal clocks and clock outputs to the baseband controller.

8.12 CRYSTAL CIRCUIT

Due to the need for clock accuracy, the LMX9820 has a dedicated crystal oscillator. The LMX9820 uses the crystal to supply a 12 MHz clock source to the baseband controller. The 12 MHz is buffered, providing a receive data clock to the baseband controller. It is also possible to configure the crystal oscillator for input only when another high quality crystal oscillator is available in the system. The LMX9820 can accommodate 12 MHz crystal.

8.13 EXTERNAL CRYSTAL OSCILLATORS

The LMX9820 contains a crystal driver circuit. This circuit operates with an external crystal and capacitors to form an oscillator. See Figure 10 on page 17 and Figure 11 on page 17. The LMX9820 also can operate with an external TCXO (Temperature Compensated Crystal Oscillator).

8.13.1 Crystal

The crystal appears inductive near its resonant frequency. It forms a resonant circuit with its load capacitors. The resonant frequency may be trimmed with the crystal load capacitance.

1. Load Capacitance

For resonance at the correct frequency, the crystal should be loaded with its specified load capacitance, which is the value of capacitance used in conjunction with the crystal unit. Load capacitance is a parameter specified by the crystal, typically expressed in pF. The crystal circuit shown in Figure 11 is composed of:

- C1 (motional capacitance)
- R1 (motional resistance)
- L1 (motional inductance)
- C0 (static or shunt capacitance)

The LMX9820 provides some of the load with internal capacitors C_{int} . The remainder must come from the external capacitors labeled Ct1 and Ct2 as shown in Figure 10. Ct1 and Ct2 should have the same value for best noise

performance. Crystal load capacitance (C_L) is calculated as the following:

$$C_L = C_{int} + Ct1/Ct2$$

The C_L above does not include the crystal internal self-capacitance C_0 as shown in Figure 11 on page 17, so the total capacitance is:

$$C_{total} = C_L + C_0$$

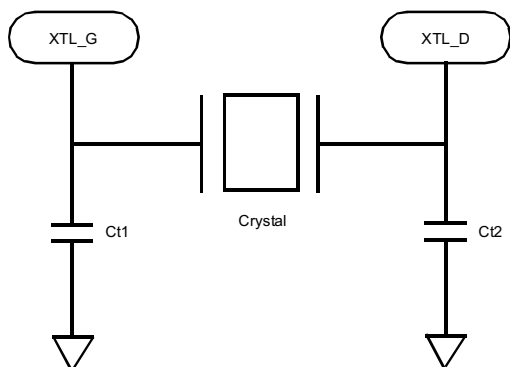

Figure 10. LMX9820 Crystal Recommended Circuit

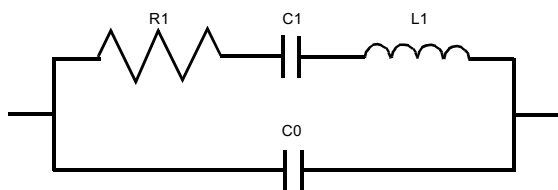

Figure 11. Crystal Equivalent Circuit

2. Crystal Pullability

Pullability is another important parameter for a crystal, which is the change in frequency of a crystal with units of ppm/pF, either from the natural resonant frequency to a load resonant frequency, or from one load resonant frequency to another. The frequency can be pulled in a parallel resonant circuit by changing the value of load capacitance. A decrease in load capacitance causes an increase in frequency, and an increase in load capacitance causes a decrease in frequency.

3. Frequency Tuning

Frequency Tuning is achieved by adjusting the crystal load capacitance with external capacitors. It is a Bluetooth requirement that the frequency is always within ± 20 ppm. Crystal/oscillator must have cumulative accuracy specifications of ± 15 ppm to provide margin for frequency drift with ageing and temperature.

4. Vite Crystal

The VXE4-1055 is a 12 MHz SMT crystal from Vite. National is using this crystal with the LMX9820. Table 21 on page 17 shows the specification of VXE4-1055.

Since the internal capacitance of the crystal circuit is 4-5 pF and the load capacitance is 9 pF, 10 pF is a good starting point for both Ct1 and Ct2. The 2480 MHz RF frequency offset is then tested. Figure 12 on page 18 shows the RF frequency offset test results.

Figure 12 shows the results are 100 kHz off the center frequency, which is -4 ppm. The pullability of the crystal is 24 ppm/pF, so the load capacitance must be decreased by about 0.2 pF. By changing Ct1 or Ct2 to 9 pF, the total load capacitance is increased by 0.26 pF. Figure 13 shows the frequency offset test results. The frequency offset is now zero with Ct1 = 9 pF, Ct2 = 10 pF.

5. Kinseki KSS CX-4025S

The LMX9820 has also been tested with the Kinseki KSS CX-4025S. See Table 22 on page 17.

Table 21. VXE4-1055-12M000

Specification	Value
Package	6.0x3.5x1.1 mm - 4 pads
Frequency	12.000 MHz
Mode	Fundamental
Stability	± 18 ppm at -20 to $+70^\circ\text{C}$ (inclusive of all conditions)
Load Capacitance	9 pF
ESR	40 Ω max, 20 Ω typ
Shunt Capacitance	7 pF max
Drive Level	10 to 100 μW
Pullability	24 ppm/pF min
Storage Temperature	-40 to $+85^\circ\text{C}$

Table 22. KSS CX-4025S

Specification	Value
Package	4.0x2.5x0.75 mm - 4 pads
Frequency	12.000 MHz
Mode	Fundamental
Stability	± 20 ppm at -30 to $+80^\circ\text{C}$ (inclusive of all conditions)
Load Capacitance	12pF
ESR	80 Ω max, 20 Ω typ
Shunt Capacitance	3 pF max
Drive Level	100 μW max
Storage Temperature	-40 to $+85^\circ\text{C}$

8.0 Digital Smart Radio (Continued)

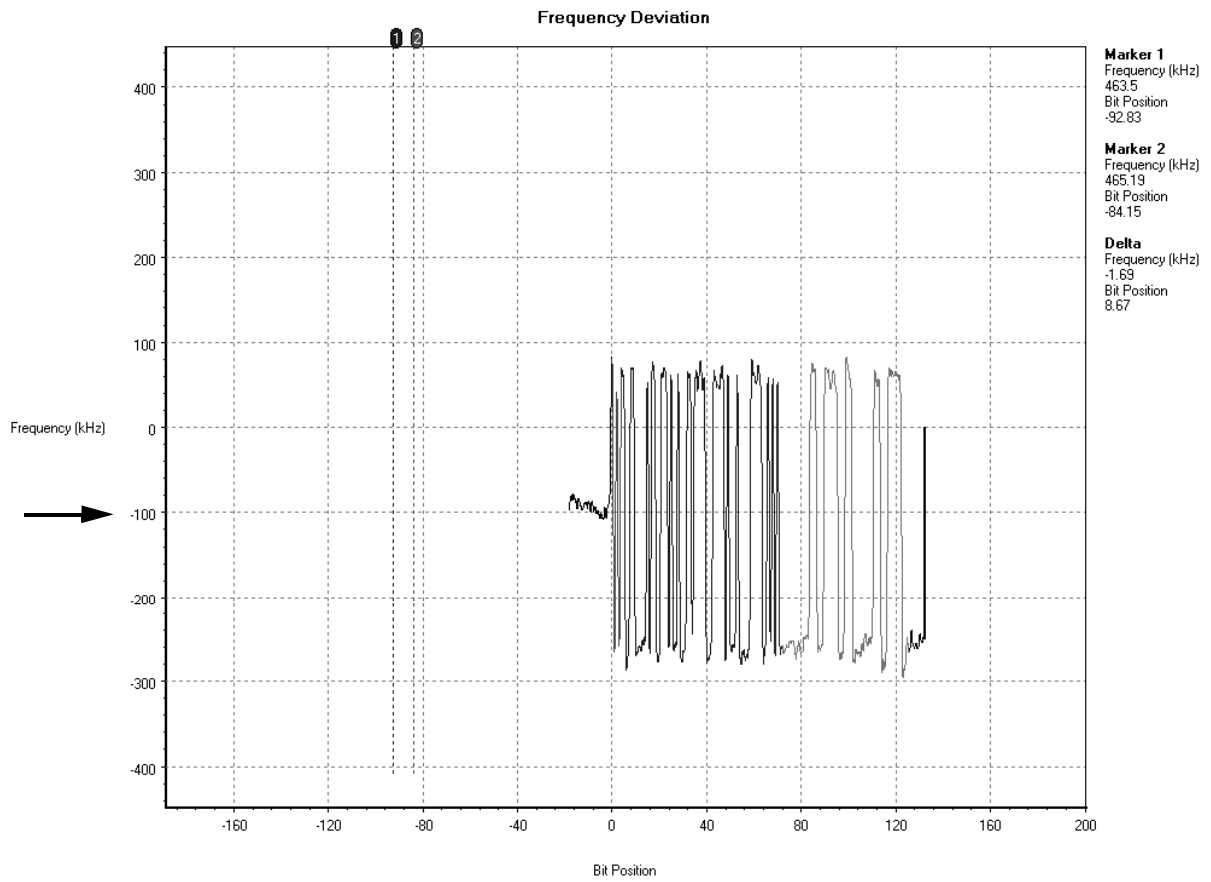
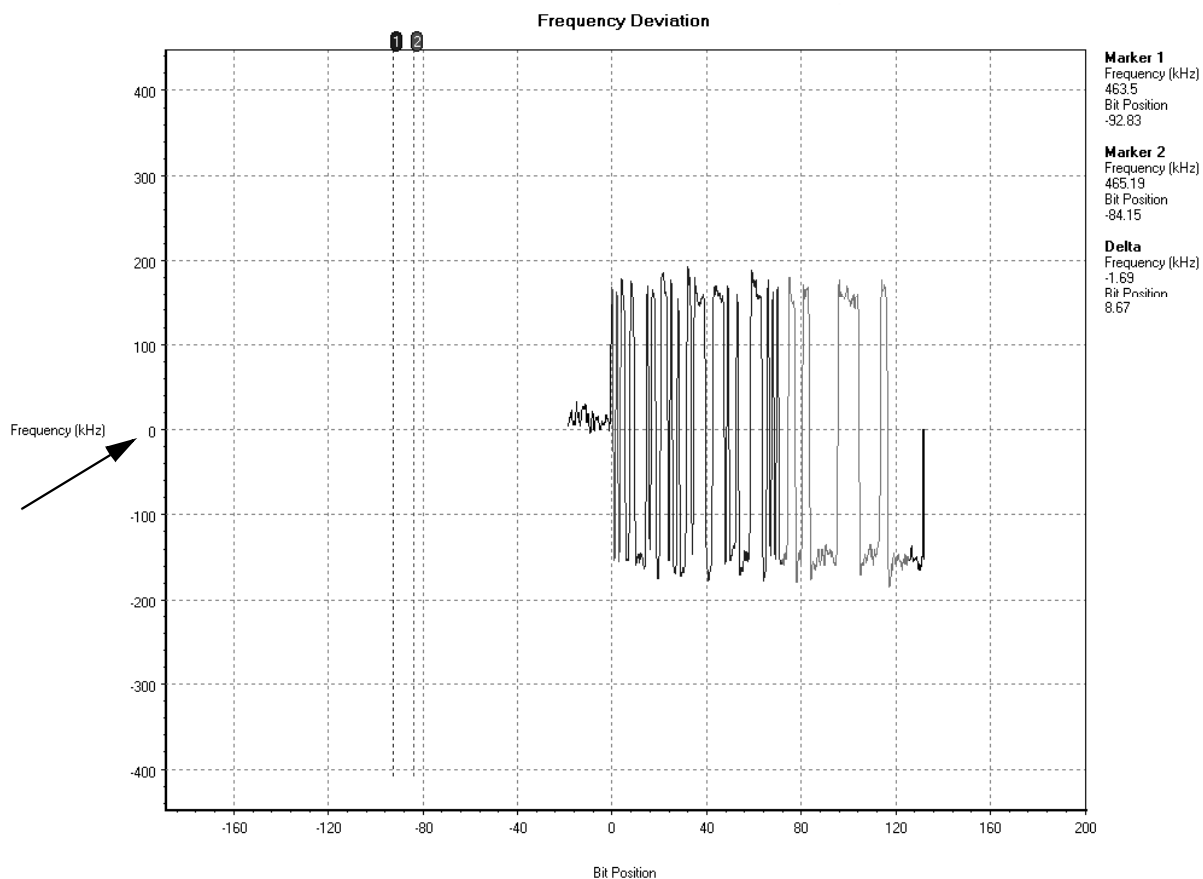

Figure 12. Frequency Offset with 10 pF // 10 pF Capacitors

8.0 Digital Smart Radio (Continued)



Created 6/27/2003 3:25:05 PM using BlueSuite PRO by Anritsu

Figure 13. Frequency Offset with 9 pF//10 pF Capacitors

8.13.2 TCXO (Temperature Compensated Crystal Oscillator)

The LMX9820 also can operate with an external TCXO (Temperature Compensated Crystal Oscillator). The TCXO signal is directly connected to the XTL_G.

Input Impedance

The LMX9820 XTL_G pin has in input impedance of 2pF capacitance in parallel with >400kΩ resistance.

NKG3184A TCXO

The LMX9820 has also been tested with the NKG3184A TCXO. See Table 23 on page 19.

Table 23. TCXO - NKG3184A

Specification	Value
Package	5.0x3.2x1.4 mm - 4 pads
Frequency	12.000 MHz
Stability	±18 ppm at -30 to +85°C (inclusive of all conditions)
Output Load	10kΩ // 13pF
Current Consumption	2.0mA
Output Level	0.3Vp-p to 2.0Vp-p
Storage Temperature	-40 to +85°C
DC Cut Capacitor	Included in VC-TCXO

9.0 System Power-Up Sequence

In order to correctly power-up the LMX9820 the following sequence must be performed:

Apply IOVCC and VCC to the LMX9820.

The Reset_b# and Reset_5100# of the LMX9820 should be driven high minimum of 2ms after the LMX9820 voltage rails are high. The LMX9820 is properly reset.

Reference Table 24 on page 20.

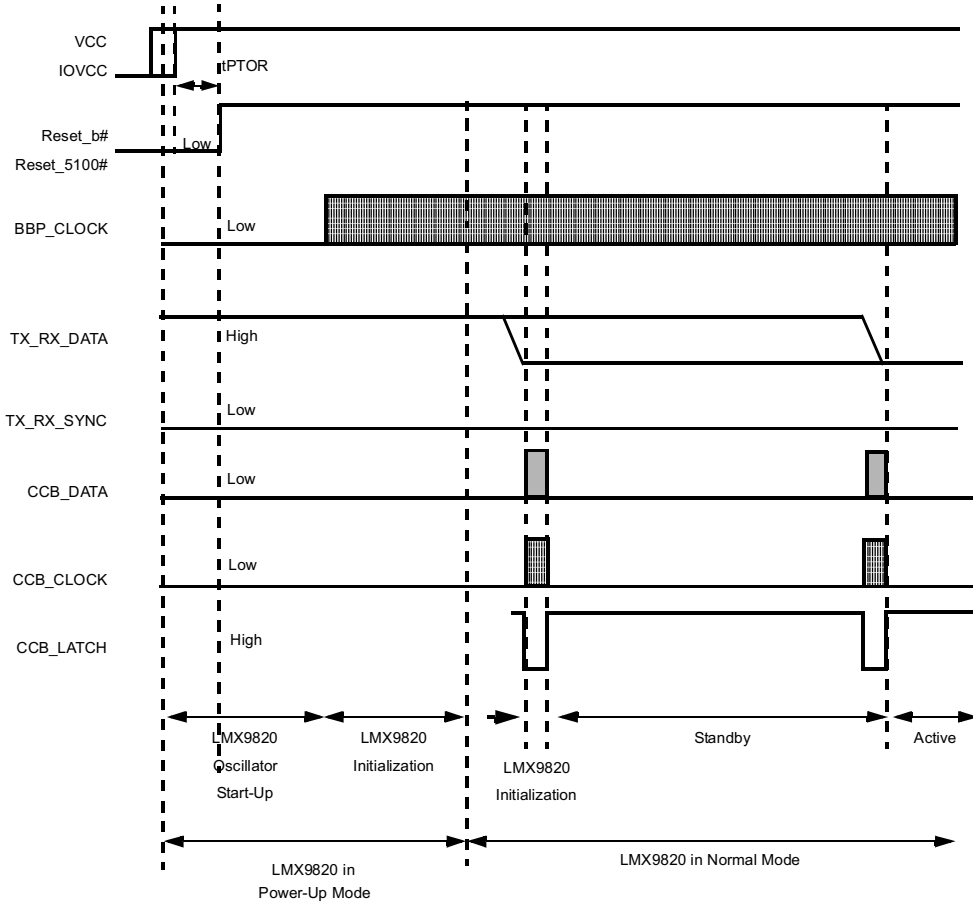

Figure 14. LMX9820 System Power-Up Sequence Timing

Table 24. LMX9820 System Power-up Sequence Timing

Symbol	Parameter	Condition	Min	Typ	Max	Unit
tPTOR	Power to Reset	V _{CC} and IO _{VCC} at operating voltage level to valid reset	2			ms

10.0 Integrated Firmware

The LMX9820 includes the full Bluetooth stack up to RFCOMM to support the following profiles:

- GAP (Generic Access Profile)
- SDAP (Service Discovery Application Profile)
- SPP (Serial Port Profile)

Figure 15 shows the Bluetooth protocol stack with command interpreter interface. The command interpreter offers a number of different commands to support the functionality given by the different profiles. Execution and interface timing is handled by the control application.

The chip has an internal data area in Flash that includes the parameters shown in Table 25 on page 22.

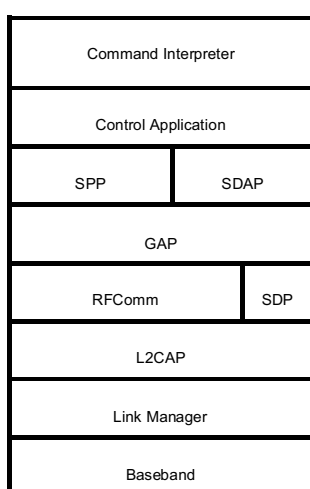

Figure 15. LMX9820 Software Implementation

10.1 FEATURES

10.1.1 Operation Modes

On boot-up, the application configures the module following the parameters in the data area.

Automatic Mode

No Default Connections Stored:

In Automatic mode the module is connectable and discoverable and automatically answers to service requests. The command interpreter listens to commands and links can be set up. The full command list is supported.

If connected by another device, the module sends an event back to the host, where the RFCOMM port has been connected, and switches to transparent mode.

Default Connections Stored:

If default connections were stored on a previous session, once the LMX9820 is reset, it will attempt to connect each device stored within the data Flash three times. The host will be notified about the success of the link setup via a link status event.

Command Mode

In Command mode, the LMX9820 does not check the default connections section within the Data Flash. If connected by another device, it will NOT switch to transparent mode and continue to interpret data sent on the UART.

Transparent Mode

The LMX9820 supports transparent data communication from the UART interface to a bluetooth link.

If activated, the module does not interpret the commands on the UART which normally are used to configure and control the module. The packages don't need to be formatted as described in Table 27 on page 24. Instead all data are directly passed through the firmware to the active bluetooth link and the remote device.

Transparent mode can only be supported on a point-to-point connection. To leave Transparent mode, the host must send a UART_BREAK signal to the module

Force Master Mode

In Force Master mode tries to act like an Accesspoint for multiple connections. For this it will only accept the link if a Master/slave role switch is accepted by the connecting device. After successful link establishment the LMX9820 will be Master and available for additional incoming links. On the first incoming link the LMX9820 will switch to transparent depending on the setting for automatic or command mode. Additional links will only be possible if the device is not in transparent mode.

10.1.2 Default Connections

The LMX9820 supports the storage of up to 3 devices within its NVS. Those connections can either be connected after reset or on demand using a specific command.

10.1.3 Event Filter

The LMX9820 uses events or indicators to notify the host about successful commands or changes at the bluetooth interface. Depending on the application the LMX9820 can be configured. The following levels are defined:

- No Events:
 - The LMX9820 is not reporting any events. Optimized for passive cable replacement solutions.
- Standard LMX9820 events:
 - only necessary events will be reported
- All events:
 - Additional to the standard all changes at the physical layer will be reported.

10.1.4 Default Link Policy

Each Bluetooth Link can be configured to support M/S role switch, Hold Mode, Sniff Mode and Park Mode. The default link policy defines the standard setting for incoming and outgoing connections.

Table 25. Operation Parameters Stored in LMX9820

Parameter	Default Value	Description
BDADDR	(Hard coded into Device)	Bluetooth device address
Local Name	Serial port device	
PinCode	0000	Bluetooth PinCode
Operation Mode	Automatic	Command or Automatic mode
Default Connections	0	Up to three default devices to connect on default
SDP Database	1 SPP entry: Name: COM1 Authentication and encryption enabled	Service discovery database, control for supported profiles
UART Speed	9600	Sets the speed of the physical UART interface to the host
UART Settings	1 Stop bit, parity disabled	Parity and stop bits on the hardware UART interface
Ports to Open	0000 0001	Defines the RFComm ports to open
Link Keys	No link keys	Link keys for paired devices
Security Mode	2	Security mode
Page Scan Mode	Connectable	Connectable/Not connectable for other devices
Inquiry Scan Mode	Discoverable	Discoverable/Not Discoverable/Limited Discoverable for other devices
Default Link Policy	All modes allowed	Configures modes allowed for incoming or outgoing connections (Role switch, Hold mode, Sniff mode, Park mode)
Default Link Timeout	20 seconds	Default link supervision timeout
Event Filter	Standard LMX9820 events reported	Defines the level of reporting on the UART - no events - standard events - standard including ACL link events

11.0 Low Power Modes

The LMX9820 supports different Low Power Modes to reduce power in different operating situations. The modular structure of the LMX9820 allows the firmware to power down unused modules.

The Low power modes have influence on:

- UART transport layer
 - enabling or disabling the interface
- Bluetooth Baseband activity
 - firmware disables LLC and Radio if possible

11.1 POWER MODES

The following LMX9820 power modes, which depend on the activity level of the UART transport layer and the radio activity are defined:

The radio activity level mainly depends on application requirements and is defined by standard bluetooth operations like inquiry/page scanning or an active link.

A remote device establishing or disconnecting a link may also indirectly change the radio activity level.

The UART transport layer by default is enabled on device power up. In order to disable the transport layer the command “Disable Transport Layer” is used. Thus only the Host side command interface can disable the transport layer. Enabling the transport layer is controlled by the HW Wakeup signalling. This can be done from either the Host and the LMX9820. See also “LMX9820 Software Users Guide” for detailed information on timing and implementation requirements.

Table 26. Power Mode activity

Power Mode	UART activity	Radio activity
PM0	OFF	OFF
PM1	ON	OFF
PM2	OFF	Scanning
PM3	ON	Scanning
PM4	OFF	SPP Link
PM5	ON	SPP Link

11.2 ENABLING AND DISABLING UART TRANSPORT

11.2.1 Hardware Wake up functionality

In certain usage scenarios the host is able to switch off the transport layer of the LMX9820 in order to reduce power consumption. Afterwards both devices, host and LMX9820 are able to shut down their UART interfaces.

In order to save system connections the UART interface is reconfigured to hardware wakeup functionality. For a detailed timing and command functionality please see also the “LMX9820 Software Users Guide”.

The interface between host and LMX9820 is defined as described in Figure 16.

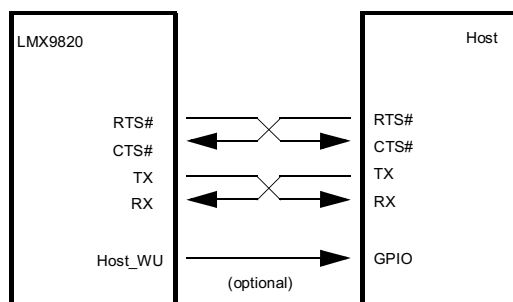

Figure 16. UART NULL modem connection

11.2.2 Disabling the UART transport layer

The Host can disable the UART transport layer by sending the “Disable Transport Layer” Command. The LMX9820 will empty its buffers, send the confirmation event and disable its UART interface. Afterwards the UART interface will be reconfigured to wake up on a falling edge of the CTS pin.

11.2.3 LMX9820 enabling the UART interface

As the Transport Layer can be disabled in any situation the LMX9820 must first make sure the transport layer is enabled before sending data to the host. Possible scenarios can be incoming data or incoming link indicators. If the UART is not enabled the LMX9820 assumes that the Host is sleeping and waking it up by activating RTS and setting HOST_WU to 1. To be able to react on that Wake up, the host has to monitor the CTS pin.

As soon as the host activates its RTS pin, the LMX9820 will first send a confirmation event and then start to transmit the events.

11.2.4 Enabling the UART transport layer from the host

If the host needs to send data or commands to the LMX9820 while the UART Transport Layer is disabled it must first assume that the LMX9820 is sleeping and wake it up using its RTS signal.

When the LMX9820 detects the Wake-Up signal it activates the UART HW and acknowledges the Wake-Up signal by settings its RTS and HOST_WU signal. Additionally the Wake up will be confirmed by a confirmation event. When the Host has received this “Transport Layer Enabled” event, the LMX9820 is ready to receive commands.

12.0 Command Interface

The LMX9820 offers Bluetooth functionality in either a self contained slave functionality or over a simple command interface. The interface is listening on the UART interface.

The following sections describe the protocol transported on the UART interface between the LMX9820 and the host in command mode (see Figure 17). In Transparent mode, no data framing is necessary and the device does not listen for commands.

12.1 FRAMING

The connection is considered “Error free”. But for packet recognition and synchronization, some framing is used.

All packets sent in both directions are constructed per the model shown in Table 27.

12.1.1 Start and End Delimiter

The “STX” char is used as start delimiter: STX = 0x02. ETX = 0x03 is used as end delimiter.

12.1.2 Packet Type ID

This byte identifies the type of packet. See Table 28 for details.

12.1.3 Opcode

The opcode identifies the command to execute. The opcode values can be found within the “LMX9820 Software User’s Guide” included within the LMX9820 Evaluation Board.

12.1.4 Data Length

Number of bytes in the Packet Data field. The maximum size is defined with 333 data bytes per packet.

12.1.5 Checksum:

This is a simple Block Check Character (BCC) checksum of the bytes “Packet type”, “Opcode” and “Data Length”. The BCC checksum is calculated as low byte of the sum of all bytes (e.g., if the sum of all bytes is 0x3724, the checksum is 0x24).

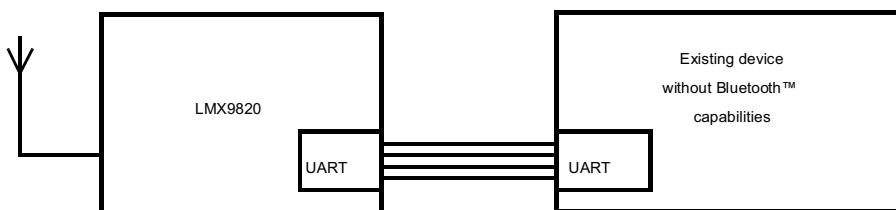

Figure 17. Bluetooth Functionality

Table 27. Package Framing

Start De-limiter	Packet Type ID	Opcode	Data Length	Checksum	Packet Data	End De-limiter
1 Byte	1 Byte	1 Byte	2 Bytes	1 Byte	<Data Length> Bytes	1 Byte
----- Checksum -----						

Table 28. Packet Type Identification

ID	Direction	Description
0x52 'R'	REQUEST (REQ)	A request sent to the Bluetooth module. All requests are answered by exactly one confirm.
0x43 'C'	Confirm (CFM)	The Bluetooth modules confirm to a request. All requests are answered by exactly one confirm.
0x69 'i'	Indication (IND)	Information sent from the Bluetooth module that is not a direct confirm to a request. Indicating status changes, incoming links, or unrequested events.
0x72 'r'	Response (RES)	An optional response to an indication. This is used to respond to some type of indication message.

12.2 COMMAND SET OVERVIEW

The LMX9820 has a well defined command set to:

- Configure the device:
 - Hardware settings
 - Local Bluetooth parameters
 - Service database
- Set up and handle links

Tables 29 through 38 show the actual command set and the events coming back from the device. A full documented description of the commands can be found in the “LMX9820 Software Users Guide”.

NOTE: For standard Bluetooth operation only commands from Table 29 through Table 31 will be used. Most of the remaining commands are for configuration purposes only.

Table 29. Device Discovery

Command	Event	Description
Inquiry	Inquiry Complete	Search for devices
	Device Found	Lists BDADDR and class of device
Remote Device Name	Remote Device Name Confirm	Get name of remote device

Table 30. SDAP Client Commands

Command	Event	Description
SDAP Connect	SDAP Connect Confirm	Create an SDP connection to remote device
SDAP Disconnect	SDAP Disconnect Confirm	Disconnect an active SDAP link
	Connection Lost	Notification for lost SDAP link
SDAP Service Browse	Service Browse Confirm	Get the services of the remote device
SDAP Service Search	SDAP Service Search Confirm	Search a specific service on a remote device
SDAP Attribute Request	SDAP Attribute Request Confirm	Searches for services with specific attributes

Table 31. SPP Link Establishment

Command	Event	Description
Establish SPP Link	Establishing SPP Link Confirm	Initiates link establishment to a remote device
	Link Established	Link successfully established
	Incoming Link	A remote device established a link to the local device
Release SPP Link	Release SPP Link Confirm	Initiate release of SPP link
SPP Send Data	SPP Send Data Confirm	Send data to specific SPP port
	Incoming Data	Incoming data from remote device
Get Link Timeout	Get Link Timeout Confirm	Get current Link Supervision timeout
Set Link Timeout	Set Link Timeout Confirm	Set Link Supervision timeout
Transparent Mode	Transparent Mode Confirm	Switch to Transparent mode on the UART

Table 32. Storing Default Connections

Command	Event	Description
Connect Default Connection	Connect Default Connection Confirm	Connects to either one or all stored default connections
Store Default Connection	Store Default Connection Confirm	Store device as default connection
Get list of Default Connections	List of Default Devices	
Delete Default Connections	Delete Default Connections Confirm	

12.0 Command Interface (Continued)

Table 33. Bluetooth Low Power Modes

Command	Event	Description
Set Default Link Policy	Set Default Link Policy Confirm	Defines the link policy used for any incoming or outgoing link.
Get Default Link Policy	Get Default Link Policy Confirm	Returns the stored default link policy
Set Link Policy	Set Link Policy Confirm	Defines the modes allowed for a specific link
Get Link Policy	Get Link Policy Confirm	Returns the actual link policy for the link
Enter Sniff Mode	Enter Sniff Mode Confirm	
Exit Sniff Mode	Exit Sniff Mode Confirm	
Enter Park Mode	Enter Park Mode Confirm	
Enter Hold Mode	Enter Hold Mode Confirm	
	Power Save Mode Changed	Remote device changed power save mode on the link

Table 34. Wake Up Functionality

Command	Event	Description
Disable Transport Layer	Transport Layer Enabled	Disabling the UART Transport Layer and activates the Hardware Wakeup function

Table 35. SPP Port Configuration and Status

Command	Event	Description
Set Port Config	Set Port Config Confirm	Set port setting for the “virtual” serial port link over the air
Get Port Config	Get Port Config Confirm	Read the actual port settings for a “virtual” serial port
	Port Config Changed	Notification if port settings were changed from remote device
SPP Get Port Status	SPP Get Port Status Confirm	Returns status of DTR, RTS (for the active RfComm link)
SPP Port Set DTR	SPP Port Set DTR Confirm	Sets the DTR bit on the specified link
SPP Port Set RTS	SPP Port Set RTS Confirm	Sets the RTS bit on the specified link
SPP Port BREAK	SPP Port BREAK	Indicates that the host has detected a break
SPP Port Overrun Error	SPP Port Overrun Error Confirm	Used to indicate that the host has detected an overrun error
SPP Port Parity Error	SPP Port Parity Error Confirm	Host has detected a parity error
SPP Port Framing Error	SPP Port Framing Error Confirm	Host has detected a framing error
	SPP Port Status Changed	Indicates that remote device has changed one of the port status bits

Table 36. Local Bluetooth Settings

Command	Event	Description
Read Local Name	Read Local Name Confirm	Read actual friendly name of the device

12.0 Command Interface (Continued)

Table 36. Local Bluetooth Settings (Continued)

Command	Event	Description
Write Local Name	Write Local Name Confirm	Set the friendly name of the device
Read Local BDADDR	Read Local BDADDR Confirm	
Change Local BDADDR	Change Local BDADDR Confirm	Note: Only use if you have your own BDADDR pool
Store Class of Device	Store Class of Device Confirm	
Set Scan Mode	Set Scan Mode Confirm	Change mode for discoverability and connectability
	Set Scan Mode Indication	Reports end of Automatic limited discoverable mode
Get Fixed Pin	Get Fixed Pin Confirm	Reads current PinCode stored within the device
Set Fixed Pin	Set Fixed Pin Confirm	Set the local PinCode
Set Default Link Timeout	Set Default Link Timeout Confirm	Set Default Link Supervision Timeout for all incoming an outgoing links
Get Default Link Timeout	Get Default Link Timeout Confirm	Read Default Link Supervision Timeout for all incoming an outgoing links
Get Security Mode	Get Security Mode Confirm	Get actual Security mode
Set Security Mode	Set Security Mode Confirm	Configure Security mode for local device (default 2)
Remove Pairing	Remove Pairing Confirm	Remove pairing with a remote device
List Paired Devices	List of Paired Devices	Get list of paired devices stored in the LMX9820 data memory
Force Master Role	Force Master Role Confirm	Enables/Disables the request for Master role at incoming connections

Table 37. Local Service Database Configuration

Command	Event	Description
Store SPP Record	Store SPP Record Confirm	Create a new SPP record within the service database
Store DUN Record	Store DUN Record Confirm	Create a new DUN record within the service database
Store FAX Record	Store FAX Record Confirm	Create a new FAX record within the service database
Store OPP Record	Store OPP Record Confirm	Create a new OPP record within the service database
Store FTP Record	Store FTP Record Confirm	Create a new FTP record within the service database
Store IrMCSync Record	Store IrMCSync Record Confirm	Create a new IrMCSync record within the service database
Enable SDP Record	Enable SDP Record Confirm	Enable or disable SDP records
Delete All SDP Records	Delete All SDP Records Confirm	
Ports to Open	Ports to Open Confirmed	Specify the RFCOMM Ports to open on startup

12.0 Command Interface (Continued)

Table 38. Local Hardware Commands

Command	Event	Description
Set Event Filter	Set Event Filter Confirm	Configures the reporting level of the command interface
Get Event Filter	Get Event Filter Confirm	Get the status of the reporting level
Read RSSI	Read RSSI Confirm	Returns an indicator for the incoming signal strength
Change UART Speed	Change UART Speed Confirm	Set specific UART speed; needs proper ISEL pin setting
Change UART Settings	Change UART Settings Confirm	Change configuration for parity and stop bits
Test Mode	Test Mode Confirm	Enable Bluetooth, EMI test, or local loopback
Restore Factory Settings	Restore Factory Settings Confirm	
Reset	Dongle Ready	Soft reset
Firmware Upgrade		Stops the bluetooth firmware and executes the In-system-programming code

13.0 Usage Scenarios

13.1 SCENARIO 1: POINT-TO-POINT CONNECTION

LMX9820 acts only as slave, no further configuration is required.

Example: Sensor with LMX9820; hand-held device with standard Bluetooth option.

The SPP conformance of the LMX9820 allows any device using the SPP to connect to the LMX9820.

Because of switching to Transparent automatically, the controller has no need for an additional protocol layer; data is sent raw to the other Bluetooth device.

On default, a PinCode is requested to block unallowed targeting.

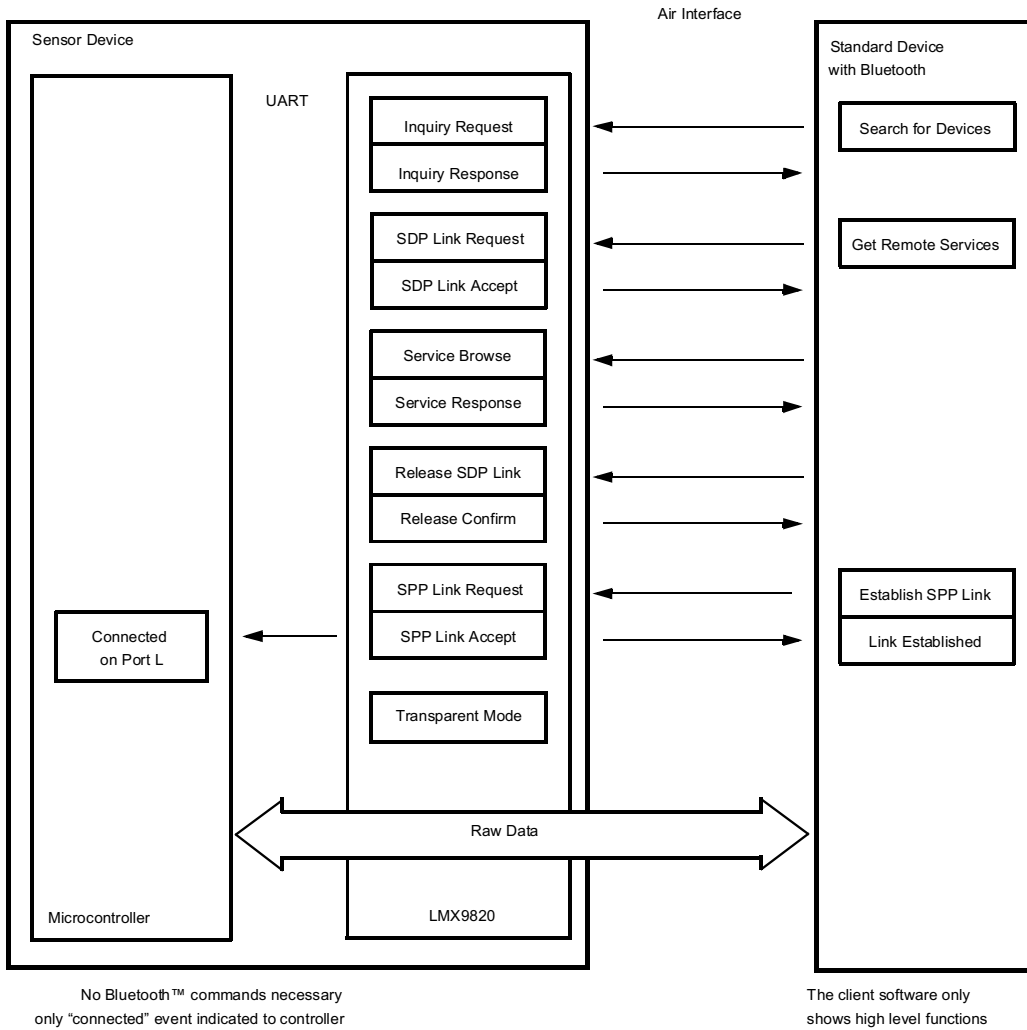

Figure 18. Point-to-Point Connection

13.0 Usage Scenarios (Continued)

13.2 SCENARIO 2: AUTOMATIC POINT-TO-POINT CONNECTION

LMX9820 at both sides.

Example: Serial Cable Replacement.

Device #1 controls the link setup with a few commands as described.

If step 5 is executed, the stored default device is connected (step 4) after reset (in Automatic mode only) or by sending the command "Connect to Default Device". The command can be sent to the device at any time.

If step 6 is left out, the microcontroller has to use the command "Send Data" instead of sending data directly to the module.

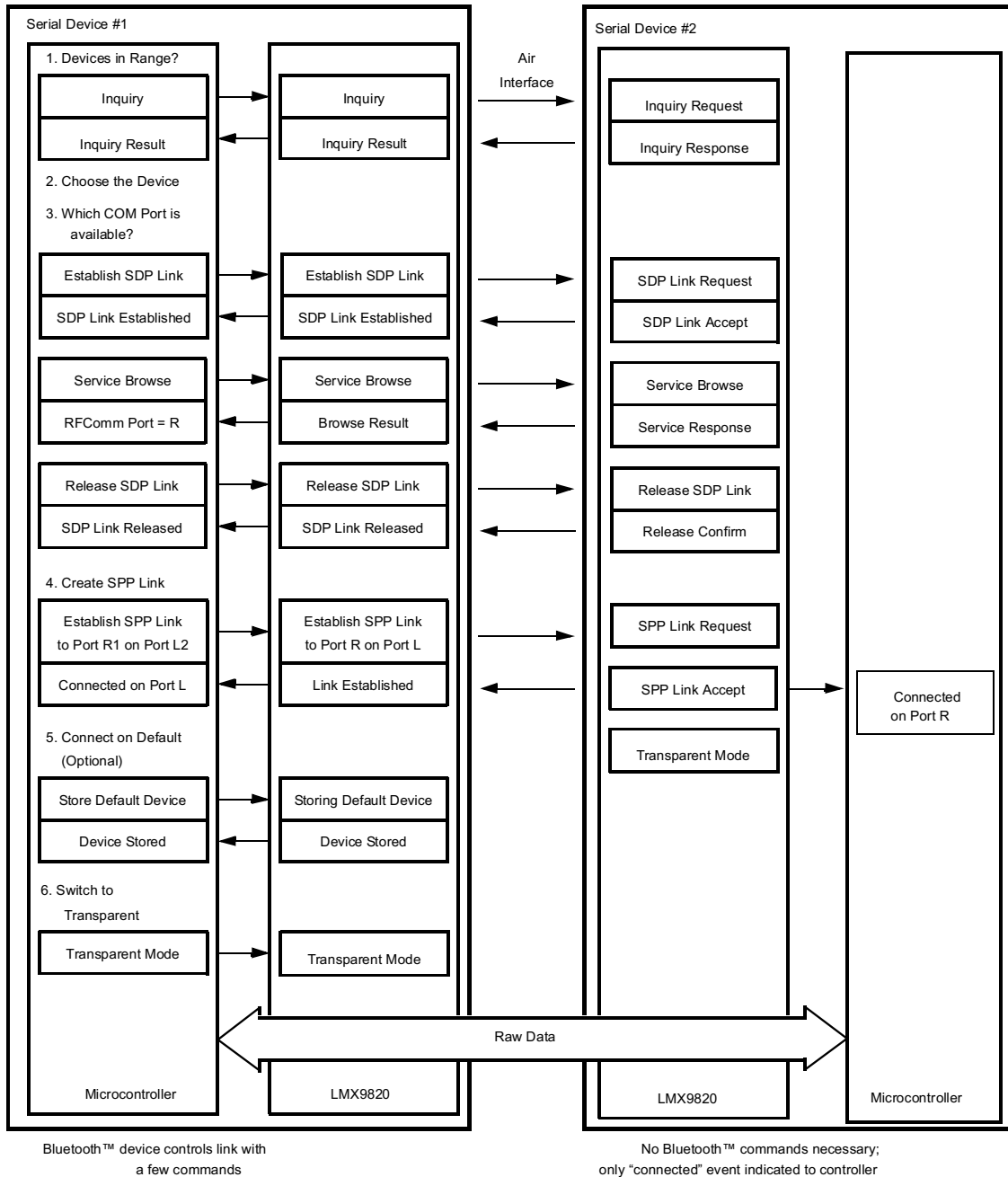

- 1. Port R indicates the remote RfComm channel to connect to. Usually the result of the SDP request.
- 2. Port L indicates the Local RfComm channel used for that connection.

Figure 19. Automatic Point-to-Point Connection

13.3 SCENARIO 3: POINT-TO-MULTIPOINT CONNECTION

LMX9820 acts as master for several slaves.

Example: Two sensors with LMX9820; one hand-held device with implemented LMX9820.

Serial Devices #2 and #3 establish the link automatically as soon as they are contacted by another device. No controller interaction is necessary for setting up the Bluetooth link. Both switch automatically into Transparent mode. The host sends raw data over the UART.

Serial Device #1 is acting as master for both devices. As the host has to decide to or from which device data is coming from, data must be sent using the "Send data command". If the device receives data from the other devices, it is packaged into an event called "Incoming data event". The event includes the device related port number.

If necessary, a link configuration can be stored as default in the master Serial Device #1 to enable the automatic reconnect after reset, power-up, or by sending the "connect default connection" command.

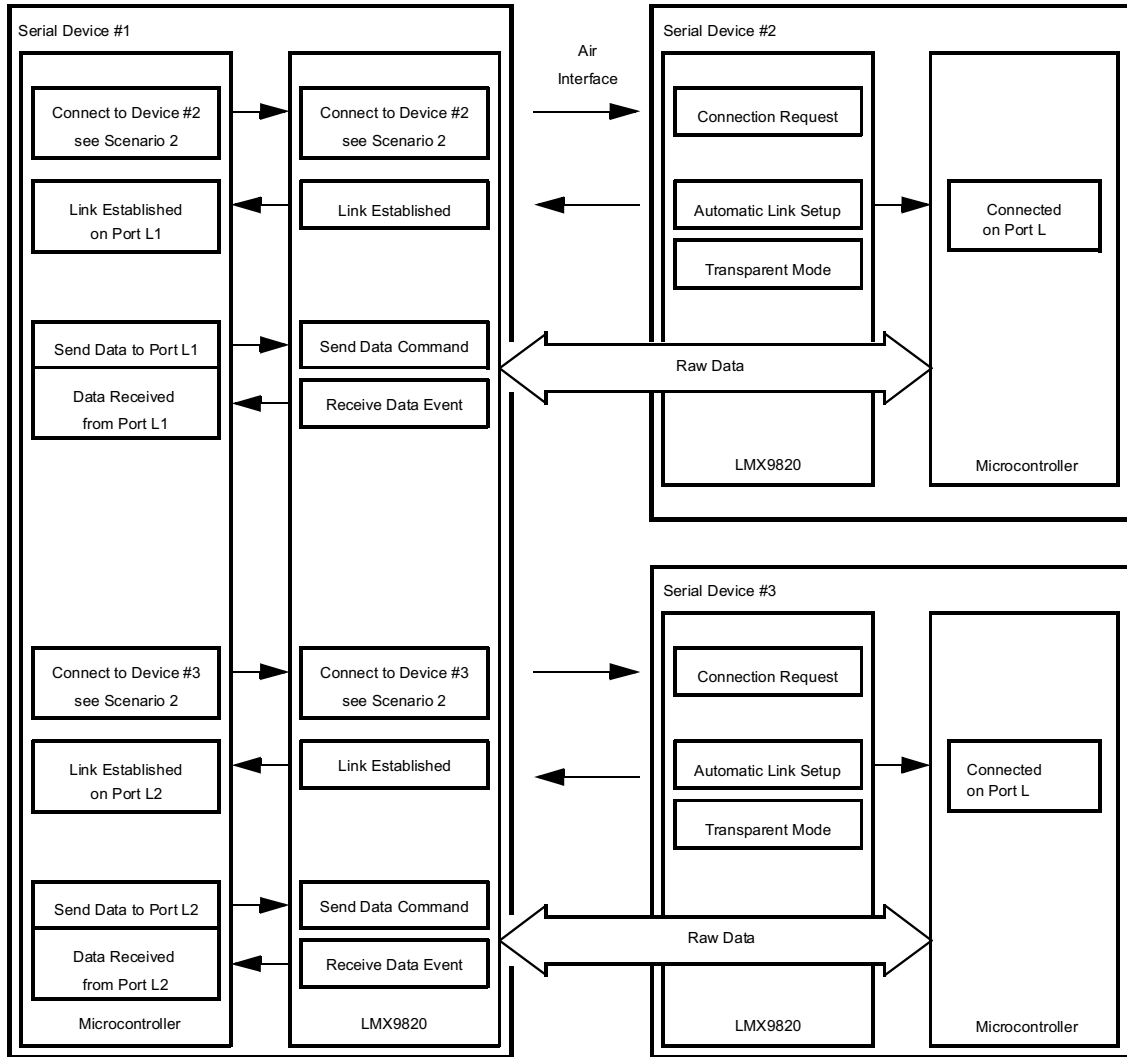

Figure 20. Point-to-Multipoint Connection

14.0 Application Information

Figure 21 on page 32 represents a typical system schematic for the LMX9820.

14.1 MATCHING NETWORK

The antenna matching network may or may not be required, depending upon the impedance of the antenna chosen. A 6.8pF blocking capacitor is recommended.

14.2 FILTERED POWER SUPPLY

It is imperative that the LMX9820 be provided with adequate Ground planes and a filtered power supply. It is highly recommended that a 0.1 μ F and a 10 pF bypass capacitor be placed as close as possible to VCC (pad H2) on the LMX9820.

14.3 HOST INTERFACE

To set the logic thresholds of the LMX9820 to match the host system, IOVCC (pad H12) must be connected to the logic power supply of the host system. It is highly recommended that a 10 pF bypass capacitor be placed as close as possible to the IOVCC pad on the LMX9820.

ISEL2 (pad H13) and ISEL1 (pad J13) can be strapped to the host logic 0 and 1 levels to set the host interface boot-up configuration. Alternatively both ISEL2 and ISEL1 can be hardwired over 10K Ω pull-up/pull-down resistors. Env0 (pad E9) and Env1 (pad B11) can be left unconnected (both are read as high) if no ISP capability is required. If the environment mode ISP needs to be activated by hardware (alternatively a firmware upgrade command can be used) then Env0 must be set to Logical Low and Reset needs to be set. Upon removal of Reset, the LMX9820 boots into the mode corresponding to the values present on Env0 and Env1.

14.4 CLOCK INPUT

The clock source must be placed as close as possible to the LMX9820. The quality of the radio performance is directly related to the quality of the clock source connected to the oscillator port on the LMX9820. Careful attention must be paid to the crystal/oscillator parameters or radio performance could be drastically reduced.

14.5 SCHEMATIC AND LAYOUT EXAMPLES

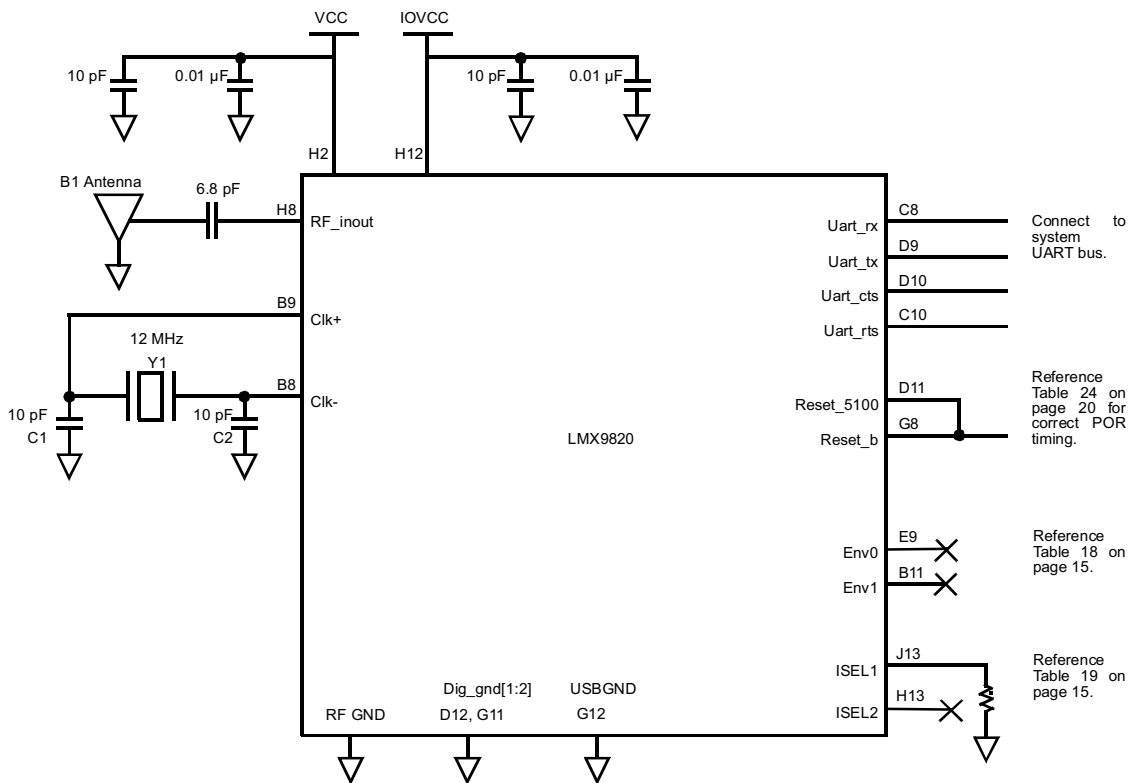

Notes:

Capacitor values, C1, C2, C31 & C32, may vary depending on board design crystal manufacturer specification. Single ground plane is used for both RF and Digital grounds.

Figure 21. Example System Schematic with pre-selected 115.2kbit/s UART speed

14.0 Application Information (Continued)

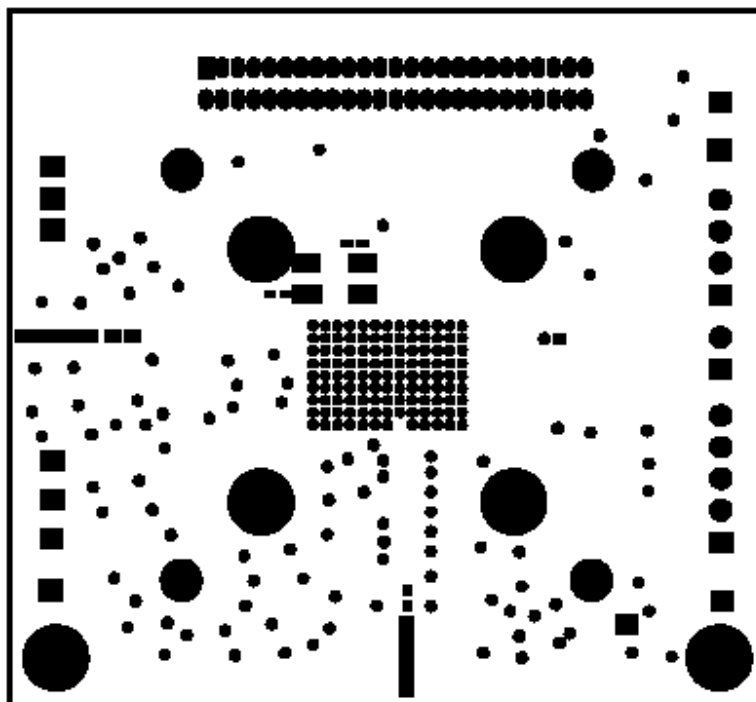
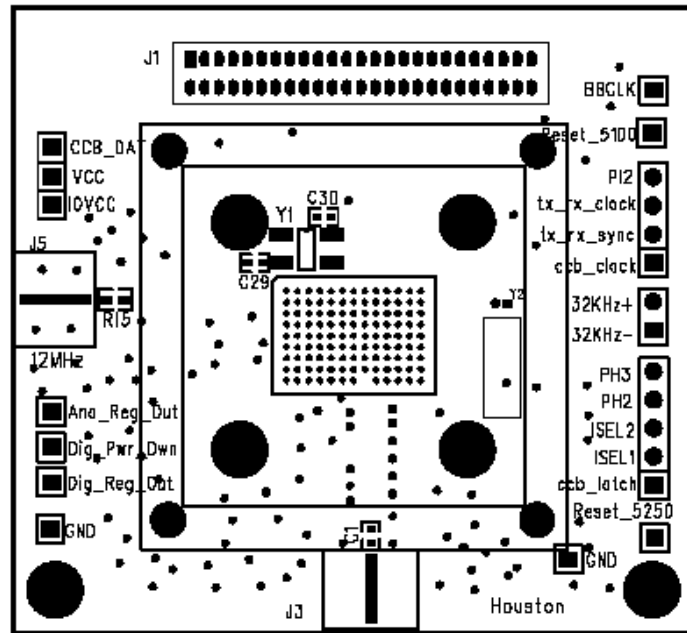

Figure 22. Component Placement - Layer 1

14.0 Application Information (Continued)

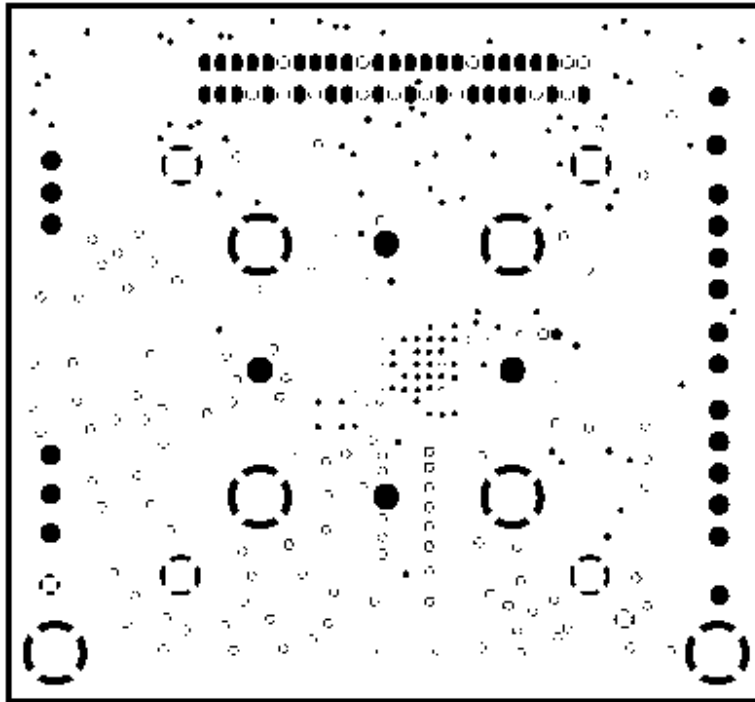

Figure 23. Solid Ground Plane - Layer 2

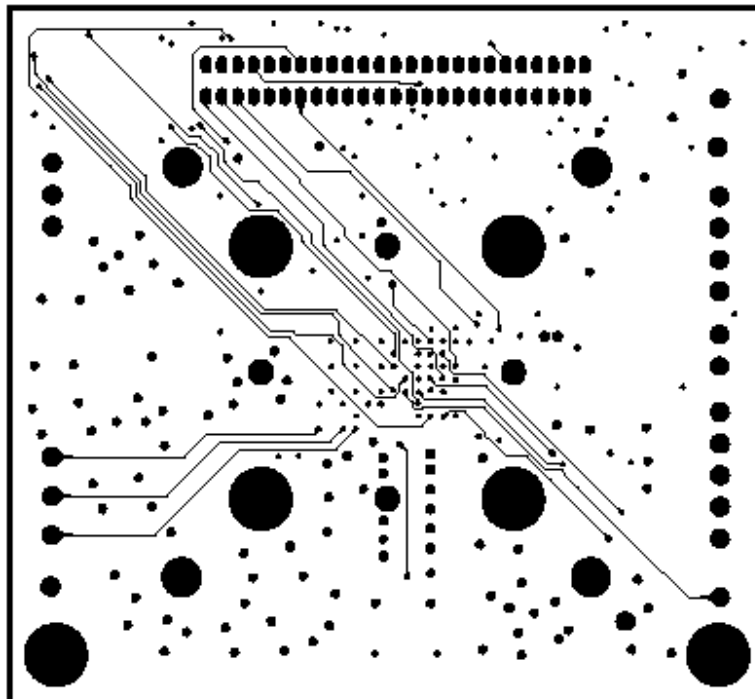

Figure 24. Signal Plane - Layer 3

14.0 Application Information (Continued)

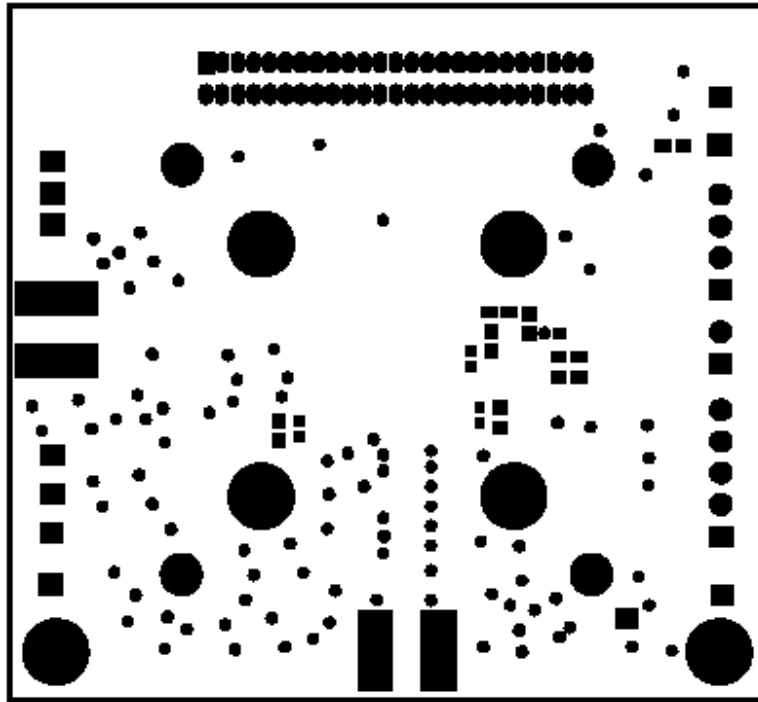

Figure 25. Component Layout Bottom - Layer 4

15.0 Soldering

The LMX9820 bumps are designed to melt as part of the Surface Mount Assembly (SMA) process. The LMX9820 is assembled with a high temperature solder alloy to ensure there are no re-reflow conditions imposed upon the module when reflowed to a PCB with these typical low temperature 60/40 (S = 183°C, L = 188°C), 62/36/2 (E = 179°C), or 63/37 (E = 183°C) solder alloys.

Where:

- S: Solidus
 - Denotes the points in a phase diagram representing the temperature at which the solder composition begins to melt during heating, or complete freezing during cooling.
- L: Liquidus
 - Denotes the points in a phase diagram representing

the temperature at which the solder has molten components. The temperature that melting starts at.

- E: Eutectic
 - Denotes solid to liquid without a plastic phase.

The low temperature solder alloy will reflow with the solder bump and provide the maximum allowable solder joint reliability.

Reflow at a peak of 215 --> 220°C (approximately 30 seconds at peak) [not to exceed 225°C; measured in close proximity of the modules] to avoid any potential re-reflow conditions.

Table 39 and Figure 26 on page 37 provide the soldering details required to properly solder the LMX9820 to standard PCBs. The illustration serves only as a guide and National is not liable if a selected profile does not work.

Table 39. Soldering Details

Parameter	Value
PCB Land Pad Diameter	24 mil
PCB Solder Mask Opening	30 mil
PCB Finish (HASL details)	63/37 (difference in thickness < 28 micron)
Stencil Aperture	28 mil
Stencil Thickness	5 mil
Solder Paste Used	Low temperature 60/40 (S = 183°C, L = 188°C), 62/36/2 (E = 179°C), or 63/37 (E = 183°C) solder alloys ¹
Flux Cleaning Process	No Clean Flux System ¹
Reflow Profiles	See Figure 26 on page 37

1. Typically defined by customer.

15.0 Soldering (Continued)

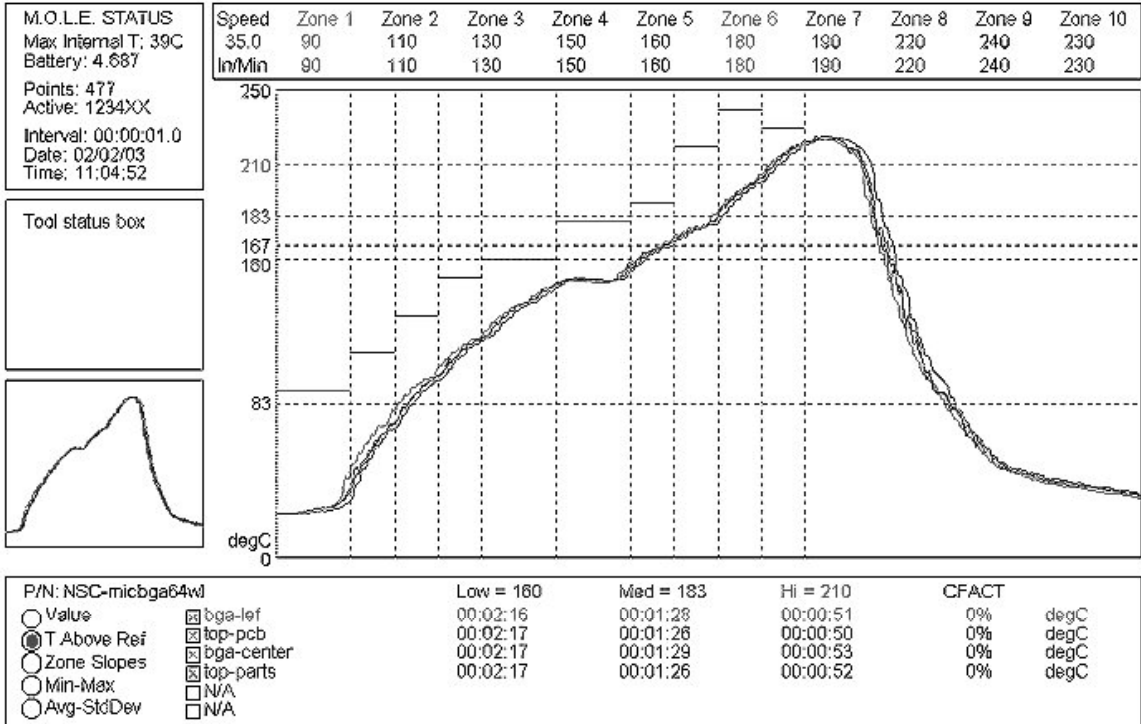

Profile #	Peak	Min	Max Rising Slope	Max Falling Slope	Rising Time 130	Time Between 130/160	Rising Time 160	Time Between 160/183	Total Time Above 183
1	213.9	32.8	2.50	-1.60	208.01	109.00	99.01	57.00	75.00
2	206.7	31.1	2.41	-1.73	213.01	121.01	92.00	53.00	64.00

Figure 26. Typical Reflow Profiles

16.0 Datasheet Revision History

This section is a report of the revision/creation process of the datasheet for the LMX9820. Table 40 provides the

stages/definitions of the datasheet. Table 41 lists the revision history and Table 42 lists the specific edits to create the current revision.

Table 40. Documentation Status Definitions

Datasheet Status	Product Status	Definition
Advance Information	Formative or in Design	This datasheet contains the design specifications for product development. Specifications may change in any manner without notice.
Preliminary	First Production	This datasheet contains preliminary data. Supplementary data will be published at a later date. National Semiconductor Corporation reserves the right to make changes at any time without notice in order to improve design and supply the best possible product.S
No Identification Noted	Full production	This datasheet contains final specifications. National Semiconductor Corporation reserves the right to make changes at any time without notice in order to improve design and supply the best possible product.
Obsolete	Not in Production	This datasheet contains specifications on a product that has been discontinued by National Semiconductor Corporation. The datasheet is printed for reference information only.

Table 41. Revision History

Revision # (PDF Date)	Revisions / Comments
0.3 (January 2003)	Third draft of preliminary datasheet. First pass through tech pubs.
0.4 (April 2003)	Datasheet revised to include new radio and additional functionality. Several edits have been made to functional, performance, and electrical details.
1.0 (February 2004)	Final datasheet. Several edits have been made to performance, electrical details and command interface. See Table 42 for details.

16.0 Datasheet Revision History (Continued)

Table 42. Edits to Current Revision

Section	Revisions / Comments
General Description	<ul style="list-style-type: none"> Section "General Description" on page 1 updated <ul style="list-style-type: none"> Text Description updated Features Updated Physical dimension changed to (10.1mm x 14.0mm x 1.9mm)
Pad Description	<ul style="list-style-type: none"> Table 2 "System Interface Signals" on page 5 updated <ul style="list-style-type: none"> changed information on 32_CLK pins
Electrical Specifications	<ul style="list-style-type: none"> Table "USB Transceiver" removed Table 10 "Recommended Operating Conditions" on page 8 updated <ul style="list-style-type: none"> USB_VCC Footnote added Table 11 "Power Supply Electrical Specifications: Analog and Digital LDOs" on page 8 added Table 12 "Power Supply Requirements" on page 9 updated Table 13 "Digital DC Characteristics" on page 9 updated Table 14 "Receiver Performance Characteristics" on page 10 updated Table 15 "Transmitter Performance Characteristics" on page 11 updated Figure 9 "Transceiver Return Loss" on page 14 added
Functional Description	<ul style="list-style-type: none"> Section 7.1.4 "Application with command interface" on page 14 updated Section 7.2 "Memory" on page 14 updated Section 7.4.3 "Interface Select Inputs (ISEL1, ISEL2)" on page 15 updated Section 7.4.4 "Module and Link Status Outputs" on page 15 updated Table 20 "Module / Link Status Definitions" on page 15 updated
Digital Smart Radio	<ul style="list-style-type: none"> Section 8.7 "Receive Signal Strength Indicator (RSSI)" on page 16 updated Section 8.11 "Frequency Synthesizers" on page 16 updated Section 8.13 "External Crystal Oscillators" on page 16 updated
System Power Up Sequence	<ul style="list-style-type: none"> New in this revision
Integrated Firmware	<ul style="list-style-type: none"> Section 10.1 "Features" on page 21 updated Table 25 "Operation Parameters Stored in LMX9820" on page 22 updated
Low Power Modes	<ul style="list-style-type: none"> New in this revision
Command Interface	<ul style="list-style-type: none"> Table 34 "Wake Up Functionality" on page 26 added Table 36 "Local Bluetooth Settings" on page 26 updated Table 38 "Local Hardware Commands" on page 28 updated
Application Information	<ul style="list-style-type: none"> Section 14.1 "MATCHING NETWORK" on page 32 updated Section 14.2 "FILTERED POWER SUPPLY" on page 32 updated Section 14.3 "HOST INTERFACE" on page 32 updated Figure 21 "Example System Schematic with pre-selected 115.2kbit/s UART speed" on page 32 updated
Soldering	<ul style="list-style-type: none"> Figure 26 "Typical Reflow Profiles" on page 37 updated

17.0 Physical Dimensions inches (millimeters) unless otherwise noted

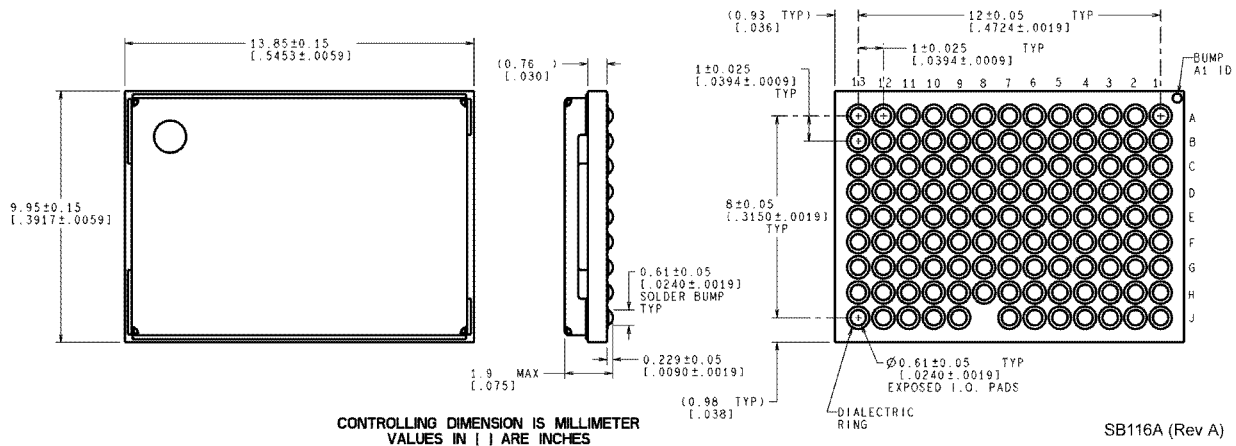

NOTES:

PAD PITCH IS 1.00 MILLIMETER (.0394") NON-ACCUMULATIVE.

UNLESS OTHERWISE SPECIFIED, ALL DIMENSIONS ARE IN INCHES.

TOLERANCE, UNLESS OTHERWISE SPECIFIED:

TWO PLACE (.00): ±.01

THREE PLACE (.000): ±.002

ANGULAR: ±1°

Figure 27. LTCC (Low Temperature Co-Fired Ceramic) Package SB116A (RevA)

LIFE SUPPORT POLICY

NATIONAL'S PRODUCTS ARE NOT AUTHORIZED FOR USE AS CRITICAL COMPONENTS IN LIFE SUPPORT DEVICES OR SYSTEMS WITHOUT THE EXPRESS WRITTEN APPROVAL OF THE PRESIDENT AND GENERAL COUNSEL OF NATIONAL SEMICONDUCTOR CORPORATION. As used herein:

- Life support devices or systems are devices or systems which, (a) are intended for surgical implant into the body, or (b) support or sustain life, and whose failure to perform, when properly used in accordance with instructions for use provided in the labeling, can be reasonably expected to result in a significant injury to the user.
- A critical component is any component of a life support device or system whose failure to perform can be reasonably expected to cause the failure of the life support device or system, or to affect its safety or effectiveness.

BANNED SUBSTANCE COMPLIANCE

National Semiconductor certifies that the products and packing materials meet the provisions of the Customer Products Stewardship Specification (CSP-9-111C2) and the Banned Substances and Materials of Interest Specification (CSP-9-111S2) and contain no "Banned Substances" as defined in CSP-9-111S2.



National Semiconductor Corporation
Tel: 1-800-272-9959
Fax: 1-800-737-7018
Email: support@nsc.com

National Semiconductor Europe
Fax: +49 (0) 180-530 85 86
Email: europe.support@nsc.com
Deutsch Tel: +49 (0) 69 9508 6208
English Tel: +44 (0) 870 24 0 2171
Francais Tel: +33 (0) 1 41 91 8790

National Semiconductor Asia Pacific Customer Response Group
Tel: 65-254-4466
Fax: 65-250-4466
Email: ap.support@nsc.com

National Semiconductor Japan Ltd.
Tel: 81-3-5639-7560
Fax: 81-3-5639-7507

www.national.com