

LMX2330A/LMX2331A/LMX2332A

PLLatinum™ Dual Frequency Synthesizer for RF Personal Communications

LMX2330A 2.5 GHz/510 MHz
LMX2331A 2.0 GHz/510 MHz
LMX2332A 1.2 GHz/510 MHz

The LMX233xA are available in a TSSOP 20-pin surface mount plastic package.

General Description

The LMX233xA family of monolithic, integrated dual frequency synthesizers, including prescalers, is to be used as a local oscillator for RF and first IF of a dual conversion transceiver. It is fabricated using National's ABiC IV silicon BiCMOS process.

The LMX233xA contains dual modulus prescalers. A 64/65 or a 128/129 prescaler (32/33 or 64/65 in the 2.5 GHz LMX2330A) can be selected for the RF synthesizer and a 8/9 or a 16/17 prescaler can be selected for the IF synthesizer. LMX233xA, which employs a digital phase locked loop technique, combined with a high quality reference oscillator and loop filters, provides the tuning voltages for voltage controlled oscillators to generate very stable low noise RF and IF local oscillator signals. Serial data is transferred into the LMX233xA via a three wire interface (Data, Enable, Clock). Supply voltage can range from 2.7V to 5.5V. The LMX233xA family features very low current consumption; LMX2330A—13 mA at 3V, LMX2331A—12 mA at 3V, LMX2332A—8 mA at 3V.

Features

- 2.7V to 5.5V operation
- Low current consumption
- Selectable powerdown mode: $I_{CC} = 1 \mu\text{A}$ typical at 3V
- Dual modulus prescaler:
 - LMX2330A (RF) 32/33 or 64/65
 - LMX2331A/32A (RF) 64/65 or 128/129
 - LMX2330A/31A/32A (IF) 8/9 or 16/17
- Selectable charge pump TRI-STATE® mode
- Selectable FastLock™ mode
- Small outline, plastic, surface mount TSSOP 0.173" wide package

Applications

- Portable Wireless Communications (PCS/PCN, cordless)
- Cordless and cellular telephone systems
- Wireless Local Area Networks (WLANs)
- Cable TV tuners (CATV)
- Other wireless communication systems

Functional Block Diagram

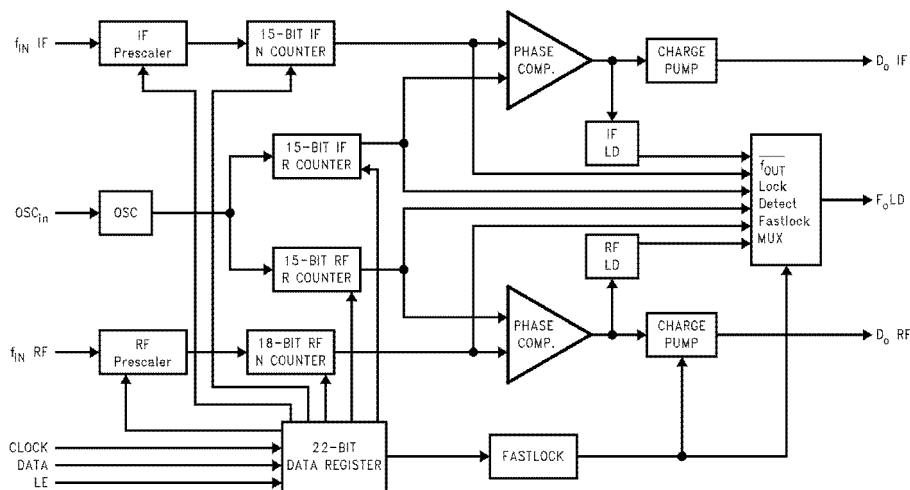

DS012331-1

TRI-STATE® is a registered trademark of National Semiconductor Corporation.
 Fastlock™, MICROWIRE™ and PLLatinum™ are trademarks of National Semiconductor Corporation.

Connection Diagram

Thin Shrink Small Outline Package (TM)

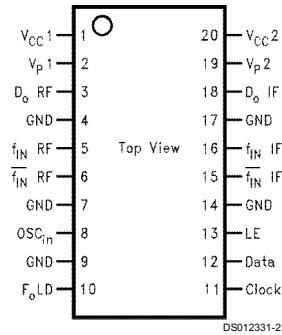

Order Number **LMX2330ATM, LMX2331ATM or LMX2332ATM**
NS Package Number **MTC20**

Pin Description

Pin No.	Pin Name	I/O	Description
1	V _{CC} 1	—	Power supply voltage input for RF analog and RF digital circuits. Input may range from 2.7V to 5.5V. V _{CC} 1 must equal V _{CC} 2. Bypass capacitors should be placed as close as possible to this pin and be connected directly to the ground plane.
2	V _P 1	—	Power Supply for RF charge pump. Must be $\geq V_{CC}$.
3	D _o RF	O	Internal charge pump output. For connection to a loop filter for driving the input of an external VCO.
4	GND	—	Ground for RF digital circuitry.
5	f _{IN} RF	I	RF prescaler input. Small signal input from the VCO.
6	f _{IN} RF	I	RF prescaler complementary input. A bypass capacitor should be placed as close as possible to this pin and be connected directly to the ground plane. Capacitor is optional with some loss of sensitivity.
7	GND	—	Ground for RF analog circuitry.
8	OSC _{in}	I	Oscillator input. The input has a V _{CC} /2 input threshold and can be driven from an external CMOS or TTL logic gate.
9	GND	—	Ground for IF digital, MICROWIRE™, F _o LD, and oscillator circuits.
10	F _o LD	O	Multiplexed output of the RF/IF programmable or reference dividers, RF/IF lock detect signals and Fastlock mode. CMOS output (<i>see Programmable Modes</i>).
11	Clock	I	High impedance CMOS Clock input. Data for the various counters is clocked in on the rising edge, into the 22-bit shift register.
12	Data	I	Binary serial data input. Data entered MSB first. The last two bits are the control bits. High impedance CMOS input.
13	LE	I	Load enable high impedance CMOS input. When LE goes HIGH, data stored in the shift registers is loaded into one of the 4 appropriate latches (control bit dependent).
14	GND	—	Ground for IF analog circuitry.
15	f _{IN} IF	I	IF prescaler complementary input. A bypass capacitor should be placed as close as possible to this pin and be connected directly to the ground plane. Capacitor is optional with some loss of sensitivity.
16	f _{IN} IF	I	IF prescaler input. Small signal input from the VCO.
17	GND	—	Ground for IF digital, MICROWIRE, F _o LD, and oscillator circuits.
18	D _o IF	O	IF charge pump output. For connection to a loop filter for driving the input of an external VCO.
19	V _P 2	—	Power Supply for IF charge pump. Must be $\geq V_{CC}$.

(Continued)

Pin Description (Continued)

Pin No.	Pin Name	I/O	Description
20	V _{CC2}	—	Power supply voltage input for IF analog, IF digital, MICROWIRE, F _o LD, and oscillator circuits. Input may range from 2.7V to 5.5V. V _{CC2} must equal V _{CC1} . Bypass capacitors should be placed as close as possible to this pin and be connected directly to the ground plane.

Block Diagram

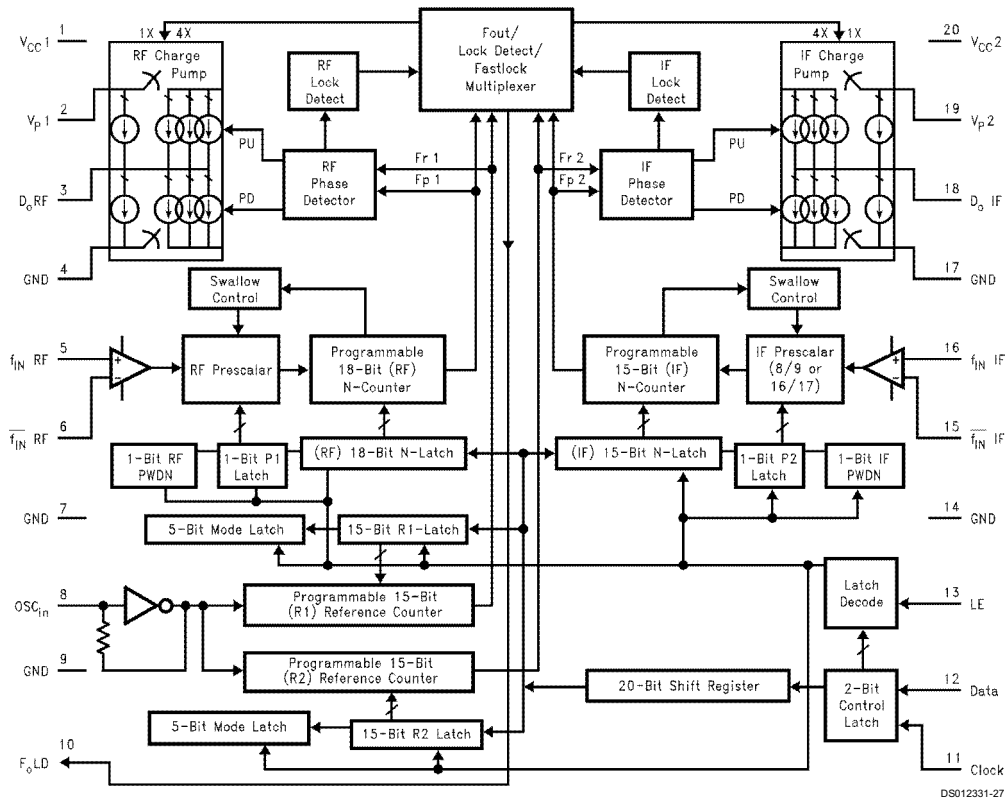

Notes:

The RF prescaler for the LMX2331A/32A is either 64/65 or 128/129, while the prescaler for the LMX2330A is 32/33 or 64/65.

V_{CC1} supplies power to the RF prescaler, N-counter, R-counter and phase detector. V_{CC2} supplies power to the IF prescaler, N-counter, phase detector, R-counter along with the OSC_{in} buffer, MICROWIRE, and F_oLD. V_{CC1} and V_{CC2} are clamped to each other by diodes and must be run at the same voltage level.

V_{P1} and V_{P2} can be run separately as long as V_P ≥ V_{CC}.

Absolute Maximum Ratings (Notes 1, 2)

If Military/Aerospace specified devices are required, please contact the National Semiconductor Sales Office/ Distributors for availability and specifications.

Power Supply Voltage

V_{CC}	-0.3V to +6.5V
V_P	-0.3V to +6.5V

Voltage on Any Pin

with GND = 0V (V_I)	-0.3V to $V_{CC}+0.3V$
-------------------------	------------------------

Storage Temperature Range (T_S)

	-65°C to +150°C
--	-----------------

Lead Temperature (solder 4 sec.) (T_L)

+260°C

Recommended Operating Conditions

Power Supply Voltage

V_{CC}	2.7V to 5.5V
V_P	V_{CC} to +5.5V

Operating Temperature (T_A)

-40°C to +85°C

Electrical Characteristics

$V_{CC} = 3.0V$, $V_P = 3.0V$; -40°C < T_A < 85°C, except as specified

Symbol	Parameter		Conditions	Value			Units
				Min	Typ	Max	
I_{CC}	Power Supply Current	LMX2330A RF + IF	$V_{CC} = 2.7V$ to 5.5V		13	16.5	mA
		LMX2330A RF Only			10	13	
		LMX2331A RF + IF			12	15.5	
		LMX2331A RF Only			9	12	
		LMX2332A IF + RF			8	10.5	
		LMX2332A RF Only			5	7	
		LMX233XA IF Only			3	3.5	
$I_{CC-PWDN}$	Powerdown Current				1	25	µA
$f_{IN\ RF}$	Operating Frequency	LMX2330A		0.5		2.5	GHz
		LMX2331A		0.2		2.0	
		LMX2332A		0.1		1.2	
$f_{IN\ IF}$	Operating Frequency	LMX233XA		45		510	MHz
f_{OSC}	Oscillator Frequency			5		40	MHz
f_{ϕ}	Phase Detector Frequency					10	MHz
$Pf_{IN\ RF}$	RF Input Sensitivity		$V_{CC} = 3.0V$	-15		+4	dBm
			$V_{CC} = 5.0V$	-10		+4	
$Pf_{IN\ IF}$	IF Input Sensitivity		$V_{CC} = 2.7V$ to 5.5V	-10		+4	dBm
V_{OSC}	Oscillator Sensitivity		OSC_{in}	0.5			V_{PP}
V_{IH}	High-Level Input Voltage		*	0.8 V_{CC}			V
V_{IL}	Low-Level Input Voltage		*			0.2 V_{CC}	V
I_{IH}	High-Level Input Current		$V_{IH} = V_{CC} = 5.5V^*$	-1.0		1.0	µA
I_{IL}	Low-Level Input Current		$V_{IL} = 0V$, $V_{CC} = 5.5V^*$	-1.0		1.0	µA
I_{IH}	Oscillator Input Current		$V_{IH} = V_{CC} = 5.5V$			100	µA
I_{IL}	Oscillator Input Current		$V_{IL} = 0V$, $V_{CC} = 5.5V$	-100			µA
V_{OH}	High-Level Output Voltage		$I_{OH} = -500\ \mu A$	$V_{CC} - 0.4$			V
V_{OL}	Low-Level Output Voltage		$I_{OL} = 500\ \mu A$			0.4	V
t_{CS}	Data to Clock Set Up Time		See Data Input Timing	50			ns
t_{CH}	Data to Clock Hold Time		See Data Input Timing	10			ns
t_{CWH}	Clock Pulse Width High		See Data Input Timing	50			ns
t_{CWL}	Clock Pulse Width Low		See Data Input Timing	50			ns
t_{ES}	Clock to Load Enable Set Up Time		See Data Input Timing	50			ns
t_{EW}	Load Enable Pulse Width		See Data Input Timing	50			ns

*Clock, Data and LE. Does not include $f_{IN\ RF}$, $f_{IN\ IF}$ and OSC_{IN} .

Note 1: Absolute Maximum Ratings indicate limits beyond which damage to the device may occur. Recommended Operating Conditions indicate conditions for which the device is intended to be functional, but do not guarantee specific performance limits. For guaranteed specifications and test conditions, see the Electrical Characteristics. The guaranteed specifications apply only for the test conditions listed.

Note 2: This device is a high performance RF integrated circuit with an ESD rating < 2 keV and is ESD sensitive. Handling and assembly of this device should only be done at ESD protected workstations.

Charge Pump Characteristics

$V_{CC} = 3.0V$, $V_P = 3.0V$; $-40^{\circ}C < T_A < 85^{\circ}C$, except as specified

Symbol	Parameter	Conditions	Value			Units
			Min	Typ	Max	
$I_{D_O-SOURCE}$	Charge Pump Output Current	$V_{D_O} = V_P/2$, $I_{CP_O} = HIGH^{**}$		-4.5		mA
I_{D_O-SINK}		$V_{D_O} = V_P/2$, $I_{CP_O} = HIGH^{**}$		4.5		mA
$I_{D_O-SOURCE}$		$V_{D_O} = V_P/2$, $I_{CP_O} = LOW^{**}$		-1.125		mA
I_{D_O-SINK}		$V_{D_O} = V_P/2$, $I_{CP_O} = LOW^{**}$		1.125		mA
I_{D_O-TRI}	Charge Pump TRI-STATE Current	$0.5V \leq V_{D_O} \leq V_P - 0.5V$ $-40^{\circ}C < T_A < 85^{\circ}C$	-2.5		2.5	nA
I_{D_O-SINK} vs $I_{D_O-SOURCE}$	CP Sink vs Source Mismatch (Note 4)	$V_{D_O} = V_P/2$ $T_A = 25^{\circ}C$		3	10	%
I_{D_O} vs V_{D_O}	CP Current vs Voltage (Note 3)	$0.5V \leq V_{D_O} \leq V_P - 0.5V$ $T_A = 25^{\circ}C$		10	15	%
I_{D_O} vs T_A	CP Current vs Temperature (Note 5)	$V_{D_O} = V_P/2$ $-40^{\circ}C < T_A < 85^{\circ}C$		10		%

** See PROGRAMMABLE MODES for I_{CP_O} description.

Note 3: See charge pump current specification definitions below.

Note 4: See charge pump current specification definitions below.

Note 5: See charge pump current specification definitions below.

Charge Pump Current Specification Definitions

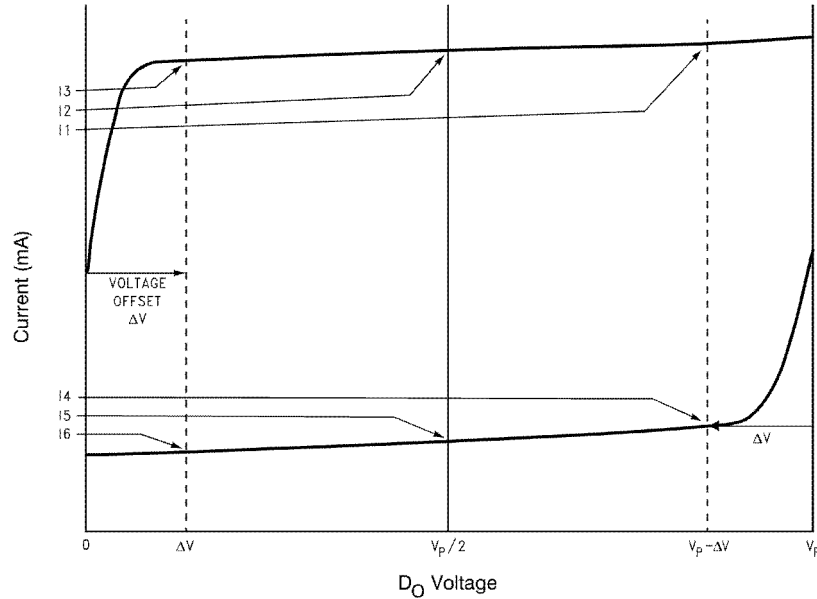

DS012331-25

- I1 = CP sink current at $V_{D0} = V_P - \Delta V$
- I2 = CP sink current at $V_{D0} = V_P/2$
- I3 = CP sink current at $V_{D0} = \Delta V$
- I4 = CP source current at $V_{D0} = V_P - \Delta V$
- I5 = CP source current at $V_{D0} = V_P/2$
- I6 = CP source current at $V_{D0} = \Delta V$

ΔV = Voltage offset from positive and negative rails. Dependent on VCO tuning range relative to V_{CC} and ground. Typical values are between 0.5V and 1.0V.

3. I_{D0} vs V_{D0} = Charge Pump Output Current magnitude variation vs Voltage = $[\frac{1}{2} * (I1 - I3)] / [\frac{1}{2} * (I1 + I3)] * 100\%$ and $[\frac{1}{2} * (I4 - I6)] / [\frac{1}{2} * (I4 + I6)] * 100\%$
4. $I_{D0-sink}$ vs $I_{D0-source}$ = Charge Pump Output Current Sink vs Source Mismatch = $|(I2 - I5)| / [\frac{1}{2} * (I2 + I5)] * 100\%$
5. I_{D0} vs T_A = Charge Pump Output Current magnitude variation vs Temperature = $|(I2 @ temp) - I2 @ 25^\circ C| / I2 @ 25^\circ C * 100\%$ and $|(I5 @ temp) - I5 @ 25^\circ C| / I5 @ 25^\circ C * 100\%$

RF Sensitivity Test Block Diagram

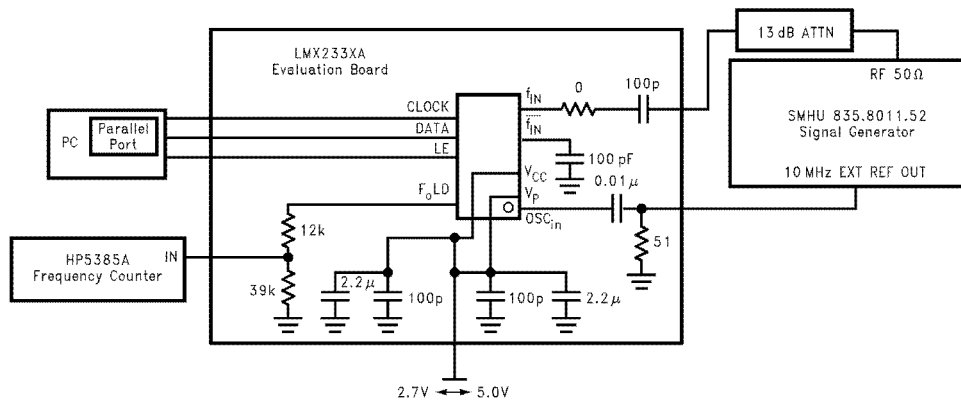

DS012331-28

Note: $N = 10,000$ $R = 50$ $P = 64$

Note: Sensitivity limit is reached when the error of the divided RF output, F_{oLD} , is ≥ 1 Hz.

Typical Performance Characteristics

I_{CC} vs V_{CC}
LMX2330A

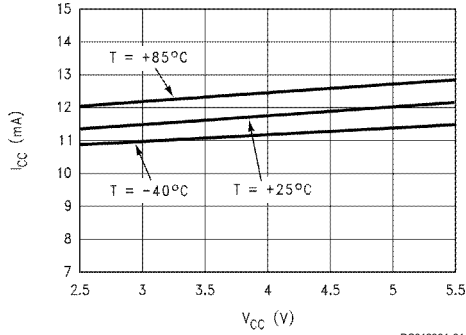

DS012331-31

I_{CC} vs V_{CC}
LMX2331A

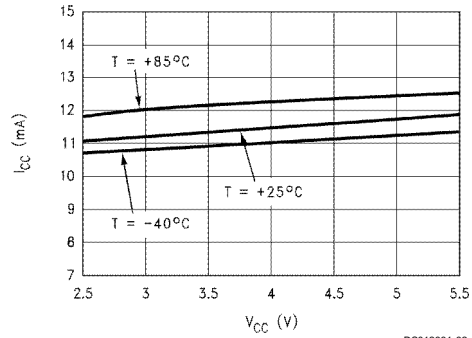

DS012331-32

I_{CC} vs V_{CC}
LMX2332A

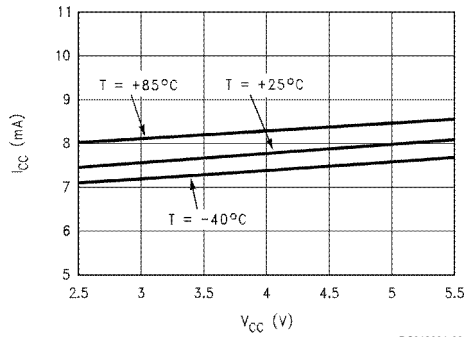

DS012331-33

I_{D_0} TRI-STATE
vs D_0 Voltage

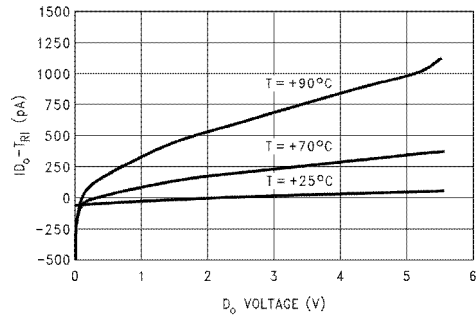

DS012331-4

Charge Pump Current vs D_0 Voltage
 $I_{CP} = \text{HIGH}$

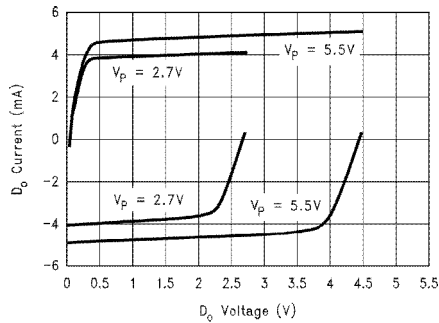

DS012331-34

Charge Pump Current vs D_0 Voltage
 $I_{CP} = \text{LOW}$

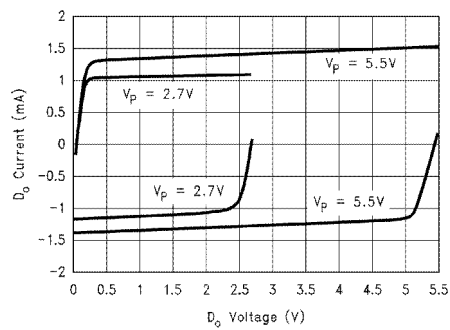

DS012331-35

Typical Performance Characteristics (Continued)

Charge Pump Current Variation (See Note 3 under Charge Pump Current Specification Definitions)

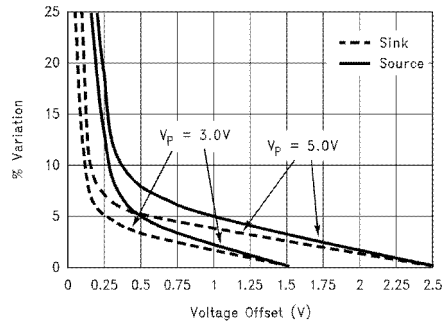

Sink vs Source Mismatch (See Note 4 under Charge Pump Current Specification Definitions)

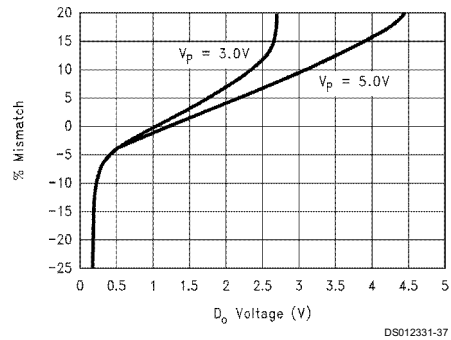

RF Input Impedance $V_{CC} = 2.7V$ to $5.5V$, $f_{IN} = 50$ MHz to 3 GHz

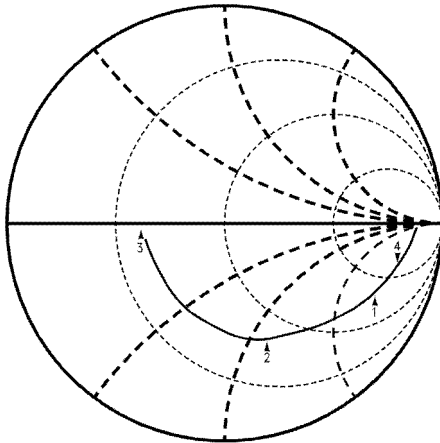

Marker 1 = 1 GHz, Real = 101, Imag. = -144
 Marker 2 = 2 GHz, Real = 37, Imag. = -54
 Marker 3 = 3 GHz, Real = 22, Imag. = -2
 Marker 4 = 500 MHz, Real = 209, Imag. = -232

IF Input Impedance $V_{CC} = 2.7V$ to $5.5V$, $f_{IN} = 10$ MHz to 1000 MHz

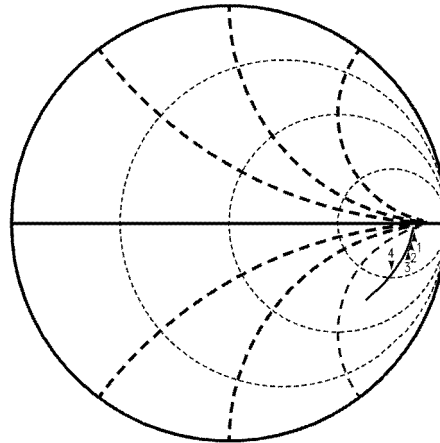

Marker 1 = 100 MHz, Real = 589, Imag. = -209
 Marker 2 = 200 MHz, Real = 440, Imag. = -286
 Marker 3 = 300 MHz, Real = 326, Imag. = -287
 Marker 4 = 500 MHz, Real = 202, Imag. = -234

Typical Performance Characteristics (Continued)

LMX2330A RF Sensitivity vs Frequency

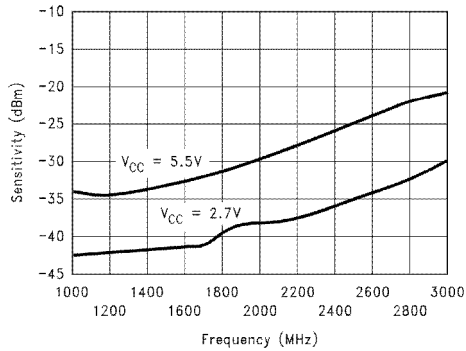

DS012331-40

LMX2331A RF Sensitivity vs Frequency

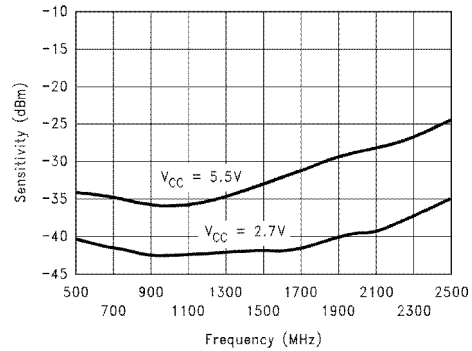

DS012331-41

LMX2332A RF Sensitivity vs Frequency

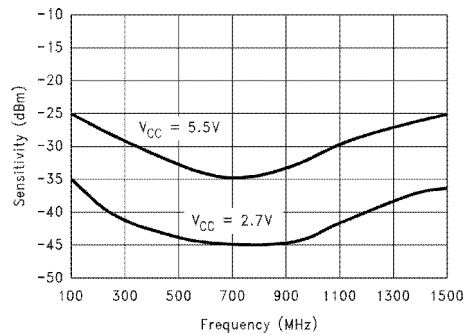

DS012331-42

IF Input Sensitivity vs Frequency

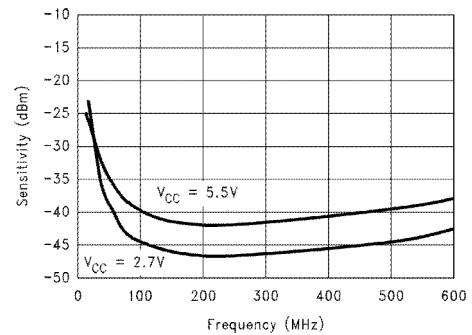

DS012331-43

Oscillator Input Sensitivity vs Frequency

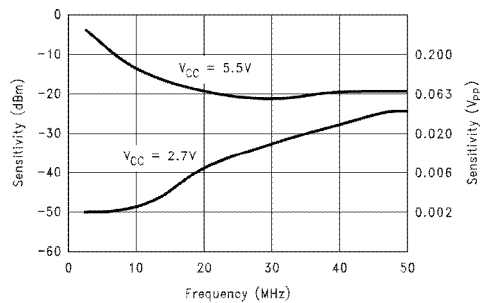

DS012331-44

Functional Description

The simplified block diagram below shows the 22-bit data register, two 15-bit R Counters and the 15- and 18-bit N Counters (intermediate latches are not shown). The DATA stream is clocked (on the rising edge of Clock) into the DATA register, MSB first. The data stored in the shift register is loaded into one of 4 appropriate latches on the rising edge of LE. The last two bits are the Control Bits. The DATA is transferred into the counters as follows:

Control Bits		DATA Location
C1	C2	
0	0	IF R Counter
0	1	RF R Counter
1	0	IF N Counter
1	1	RF N Counter

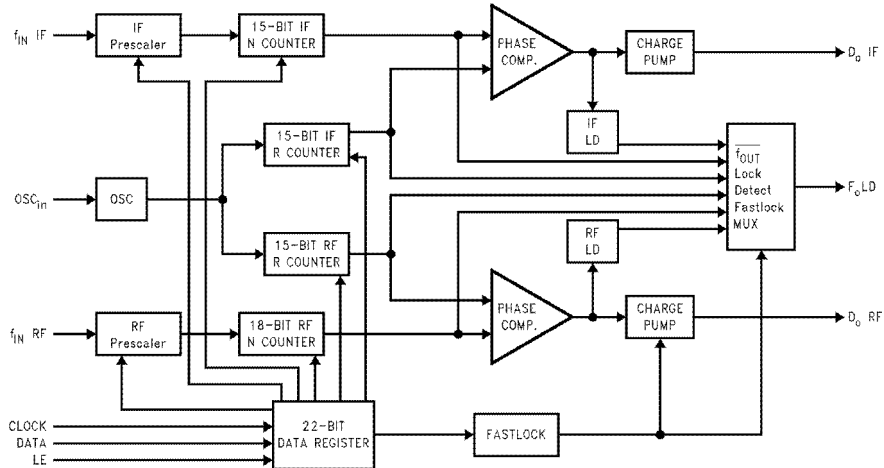

PROGRAMMABLE REFERENCE DIVIDERS (IF AND RF R COUNTERS)

If the Control Bits are 00 or 01 (00 for IF and 01 for RF) data is transferred from the 22-bit shift register into a latch which sets the 15-bit R Counter. Serial data format is shown below.

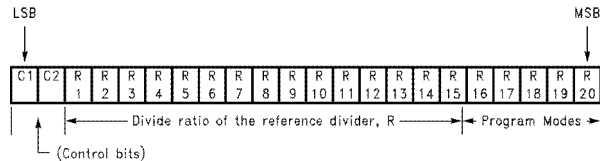

15-BIT PROGRAMMABLE REFERENCE DIVIDER RATIO (R COUNTER)

Divide Ratio	R 15	R 14	R 13	R 12	R 11	R 10	R 9	R 8	R 7	R 6	R 5	R 4	R 3	R 2	R 1
3	0	0	0	0	0	0	0	0	0	0	0	0	0	1	1
4	0	0	0	0	0	0	0	0	0	0	0	0	1	0	0
•	•	•	•	•	•	•	•	•	•	•	•	•	•	•	•
32767	1	1	1	1	1	1	1	1	1	1	1	1	1	1	1

Notes:

Divide ratios less than 3 are prohibited.

Divide ratio: 3 to 32767

R1 to R15: These bits select the divide ratio of the programmable reference divider.

Data is shifted in MSB first.

Functional Description (Continued)

PROGRAMMABLE DIVIDER (N COUNTER)

The N counter consists of the 7-bit swallow counter (A counter) and the 11-bit programmable counter (B counter). If the Control Bits are 10 or 11 (10 for IF counter and 11 for RF counter) data is transferred from the 22-bit shift register into a 4-bit or 7-bit latch (which sets the Swallow (A) Counter) and an 11-bit latch (which sets the 11-bit programmable (B) Counter), MSB first. Serial data format is shown below. **For the IF N counter bits 5, 6, and 7 are don't care bits.** The RF N counter does not have don't care bits.

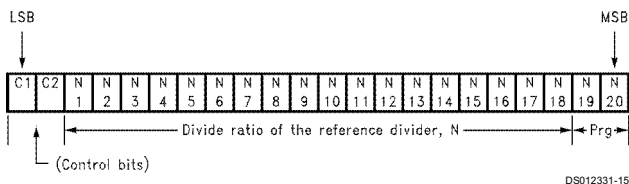

7-BIT SWALLOW COUNTER DIVIDE RATIO (A COUNTER)

RF

Divide Ratio A	N 7	N 6	N 5	N 4	N 3	N 2	N 1
0	0	0	0	0	0	0	0
1	0	0	0	0	0	0	1
•	•	•	•	•	•	•	•
127	1	1	1	1	1	1	1

Note: Divide ratio: 0 to 127
B ≥ A

IF

Divide Ratio A	N 7	N 6	N 5	N 4	N 3	N 2	N 1
0	X	X	X	0	0	0	0
1	X	X	X	0	0	0	1
•	•	•	•	•	•	•	•
15	X	X	X	1	1	1	1

X = DONT CARE condition

11-BIT PROGRAMMABLE COUNTER DIVIDE RATIO (B COUNTER)

Divide Ratio B	N 18	N 17	N 16	N 15	N 14	N 13	N 12	N 11	N 10	N 9	N 8
3	0	0	0	0	0	0	0	0	0	1	1
4	0	0	0	0	0	0	0	0	1	0	0
•	•	•	•	•	•	•	•	•	•	•	•
2047	1	1	1	1	1	1	1	1	1	1	1

Note: Divide ratio: 3 to 2047 (Divide ratios less than 3 are prohibited)
B ≥ A

PULSE SWALLOW FUNCTION

$$f_{VCO} = [(P \times B) + A] \times f_{OSC} / R$$

f_{VCO} : Output frequency of external voltage controlled oscillator (VCO)

B: Preset divide ratio of binary 11-bit programmable counter (3 to 2047)

A: Preset divide ratio of binary 7-bit swallow counter

(0 ≤ A ≤ 127 {RF}, 0 ≤ A ≤ 15 {IF}, A ≤ B)

f_{OSC} : Output frequency of the external reference frequency oscillator

R: Preset divide ratio of binary 15-bit programmable reference counter (3 to 32767)

P: Preset modulus of dual modulus prescaler (for IF; P = 8 or 16;

for RF; LMX2330A: P = 32 or 64 LMX2331A/32A: P = 64 or 128)

PROGRAMMABLE MODES

Several modes of operation can be programmed with bits R16–R20 including the phase detector polarity, charge pump TRI-STATE and the output of the F_{oLD} pin. The prescaler and powerdown modes are selected with bits N19 and N20. The programmable modes are shown in Table 1. Truth table for the programmable modes and F_{oLD} output are shown in Table 2 and Table 3.

Functional Description (Continued)

TABLE 1. Programmable Modes

C1	C2	R16	R17	R18	R19	R20
0	0	IF Phase Detector Polarity	IF I _{CP0}	IF D ₀ TRI-STATE	IF LD	IF F ₀
0	1	RF Phase Detector Polarity	RF I _{CP0}	RF D ₀ TRI-STATE	RF LD	RF F ₀

C1	C2	N19	N20
1	0	IF Prescaler	Pwdn IF
1	1	RF Prescaler	Pwdn RF

TABLE 2. Mode Select Truth Table

	Phase Detector Polarity	D ₀ TRI-STATE	I _{CP0} (Note 6)	IF Prescaler	2330A RF Prescaler	2331A/32A RF Prescaler	Pwdn (Note 7)
0	Negative	Normal Operation	LOW	8/9	32/33	64/65	PwrD Up
1	Positive	TRI-STATE	HIGH	16/17	64/65	128/129	PwrD Dn

Note 6: The I_{CP0} LOW current state = 1/4 x I_{CP0} HIGH current.

Note 7: Activation of the IF PLL or RF PLL powerdown modes result in the disabling of the respective N counter divider and debiasing of its respective f_N inputs (to a high impedance state). The powerdown function is gated by the charge pump to prevent unwanted frequency jumps. Once the powerdown program mode is loaded, the part will go into powerdown mode when the charge pump reaches a TRI-STATE condition. The R counter functionality does not become disabled until both IF and RF powerdown bits are activated. The MICROWIRE control register remains active and capable of loading and latching data during all of the powerdown modes.

TABLE 3. The F₀LD (Pin 10) Output Truth Table

RF R[19] (RF LD)	IF R[19] (IF LD)	RF R[20] (RF F ₀)	IF R[20] (IF F ₀)	F ₀ Output State
0	0	0	0	Disabled (Note 8)
0	1	0	0	IF Lock Detect (Note 9)
1	0	0	0	RF Lock Detect (Note 9)
1	1	0	0	RF/IF Lock Detect (Note 9)
X	0	0	1	IF Reference Divider Output
X	0	1	0	RF Reference Divider Output
X	1	0	1	IF Programmable Divider Output
X	1	1	0	RF Programmable Divider Output
0	0	1	1	Fastlock (Note 10)
0	1	1	1	For Internal Use Only
1	0	1	1	For Internal Use Only
1	1	1	1	Counter Reset (Note 11)

X = don't care condition

Note 8: When the F₀LD output is disabled, it is actively pulled to a low logic state.

Note 9: Lock detect output provided to indicate when the VCO frequency is in "lock." When the loop is locked and a lock detect mode is selected, the pins output is HIGH, with narrow pulses LOW. In the RF/IF lock detect mode a locked condition is indicated when RF and IF are both locked.

Note 10: The Fastlock mode utilizes the F₀LD output pin to switch a second loop filter damping resistor to ground during fastlock operation. Activation of Fastlock occurs whenever the RF loop's I_{cp0} magnitude bit #17 is selected HIGH (while the #19 and #20 mode bits are set for Fastlock).

Note 11: The Counter Reset mode bits R19 and R20 when activated reset all counters. Upon removal of the Reset bits then N counter resumes counting in "close" alignment with the R counter. (The maximum error is one prescaler cycle.) If the Reset bits are activated the R counter is also forced to Reset, allowing smooth acquisition upon powering up.

Functional Description (Continued)

PHASE DETECTOR POLARITY

Depending upon VCO characteristics, R16 bit should be set accordingly: (see figure right)

When VCO characteristics are positive like (1), R16 should be set HIGH;

When VCO characteristics are negative like (2), R16 should be set LOW.

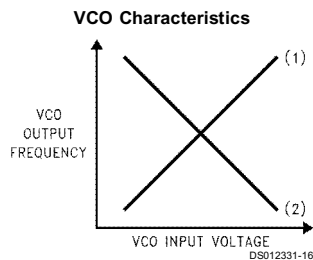

SERIAL DATA INPUT TIMING

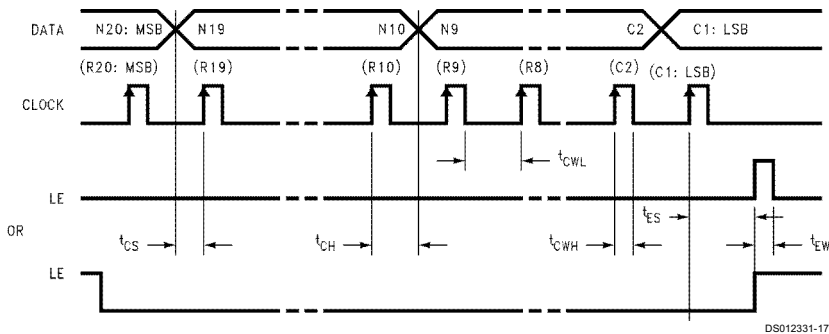

Notes: Parenthesis data indicates programmable reference divider data.

Data shifted into register on clock rising edge.

Data is shifted in MSB first.

Test Conditions: The Serial Data Input Timing is tested using a symmetrical waveform around $V_{CC}/2$. The test waveform has an edge rate of 0.6V/ns with amplitudes of 2.2V @ $V_{CC} = 2.7V$ and 2.6V @ $V_{CC} = 5.5V$.

PHASE COMPARATOR AND INTERNAL CHARGE PUMP CHARACTERISTICS

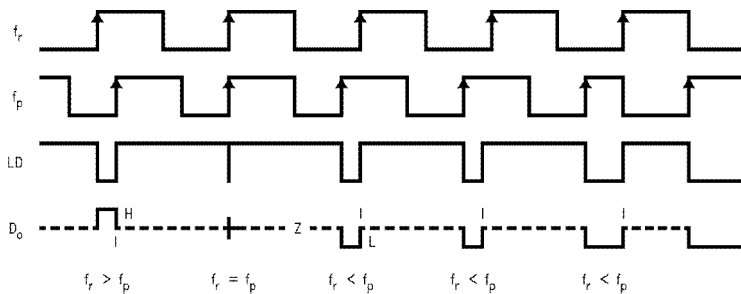

Notes: Phase difference detection range: -2π to $+2\pi$

The minimum width pump up and pump down current pulses occur at the D_o pin when the loop is locked.

R16 = HIGH

Typical Application Example

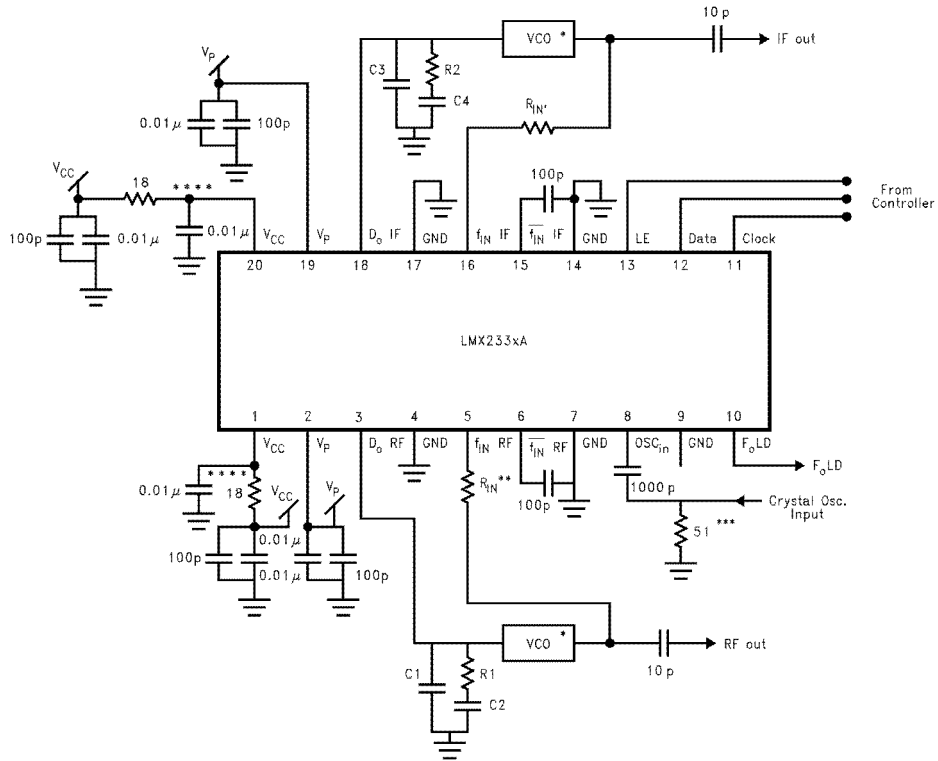

DS012331-19

Operational Notes:

- * VCO is assumed AC coupled.
- ** R_{IN} increases impedance so that VCO output power is provided to the load rather than the PLL. Typical values are 10Ω to 200Ω depending on the VCO power level. f_{IN} RF impedance ranges from 40Ω to 100Ω. f_{IN} IF impedances are higher.
- *** 50Ω termination is often used on test boards to allow use of external reference oscillator. For most typical products a CMOS clock is used and no terminating resistor is required. OSC_{in} may be AC or DC coupled. AC coupling is recommended because the input circuit provides its own bias. (See Figure below)
- **** Adding RC filters to the V_{CC} line is recommended to reduce loop-to-loop noise coupling.

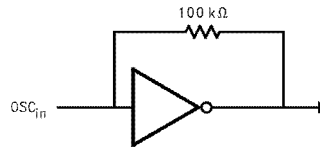

DS012331-20

Proper use of grounds and bypass capacitors is essential to achieve a high level of performance. Crosstalk between pins can be reduced by careful board layout.

This is an electrostatic sensitive device. It should be handled only at static free work stations.

Application Information

A block diagram of the basic phase locked loop is shown in *Figure 1*.

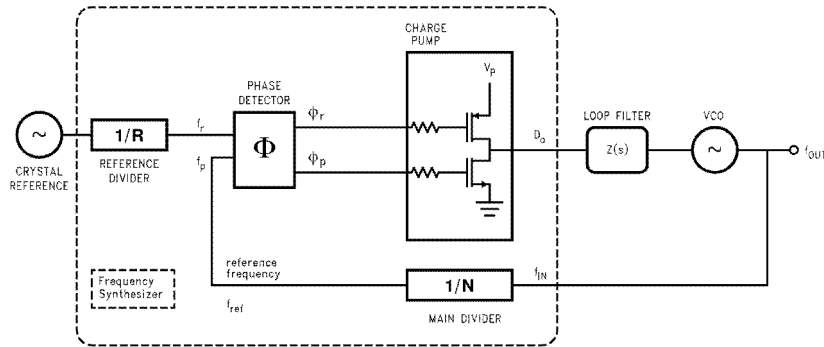

FIGURE 1. Basic Charge Pump Phase Locked Loop

LOOP GAIN EQUATIONS

A linear control system model of the phase feedback for a PLL in the locked state is shown in *Figure 2*. The open loop gain is the product of the phase comparator gain ($K\phi$), the VCO gain (K_{VCO}/s), and the loop filter gain $Z(s)$ divided by the gain of the feedback counter modulus (N). The passive loop filter configuration used is displayed in *Figure 3*, while the complex impedance of the filter is given in *Equation (2)*.

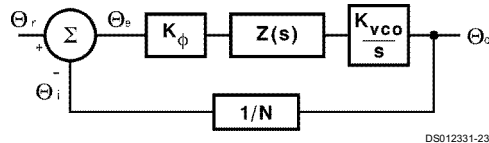

FIGURE 2. PLL Linear Model

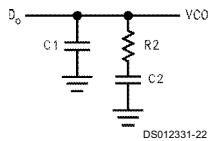

FIGURE 3. Passive Loop Filter

$$\text{Open loop gain} = H(s)G(s) = \frac{\Theta_i}{\Theta_e} = \frac{K_\phi Z(s)K_{VCO}}{Ns} \quad (1)$$

$$Z(s) = \frac{s(C2 \cdot R2) + 1}{s^2(C1 \cdot C2 \cdot R2) + sC1 + sC2} \quad (2)$$

The time constants which determine the pole and zero frequencies of the filter transfer function can be defined as

$$T1 = R2 \cdot \frac{C1 \cdot C2}{C1 + C2} \quad (3)$$

and

$$T2 = R2 \cdot C2 \quad (4)$$

The 3rd order PLL Open Loop Gain can be calculated in terms of frequency, ω , the filter time constants $T1$ and $T2$, and the design constants K_ϕ , K_{VCO} , and N .

$$G(s) \cdot H(s) \Big|_{s=j\omega} = \frac{-K_\phi \cdot K_{VCO} (1 + j\omega \cdot T2)}{\omega^2 C1 \cdot N(1 + j\omega \cdot T1)} \cdot \frac{T1}{T2} \quad (5)$$

From *Equation (3)* we can see that the phase term will be dependent on the single pole and zero such that the phase margin is determined in *Equation (6)*.

$$\phi(\omega) = \tan^{-1}(\omega \cdot T2) - \tan^{-1}(\omega \cdot T1) + 180^\circ \quad (6)$$

A plot of the magnitude and phase of $G(s)H(s)$ for a stable loop, is shown in *Figure 4* with a solid trace. The parameter ϕ_p shows the amount of phase margin that exists at the point the gain drops below zero (the cutoff frequency ω_p of the loop). In a critically damped system, the amount of phase margin would be approximately 45 degrees.

If we were now to redefine the cut off frequency, ω_p' , as double the frequency which gave us our original loop bandwidth, ω_p , the loop response time would be approximately halved. Because the filter attenuation at the comparison frequency also diminishes, the spurs would have increased by approximately 6 dB. In the proposed Fastlock scheme, the higher spur levels and wider loop filter conditions would exist only during the initial lock-on phase—just long enough to reap the benefits of locking faster. The objective would be to open up the loop bandwidth but not introduce any additional complications or compromises related to our original design criteria. We would ideally like to momentarily shift the curve of *Figure 4* over to a different cutoff frequency, illustrated by the dotted line, without affecting the relative open loop gain and phase relationships. To maintain the same gain/phase relationship at twice the original cutoff frequency, other terms in the gain and phase *Equations (5), (6)* will have to compensate by the corresponding “ $1/\omega$ ” or “ $1/\omega^2$ ” factor. Examination of *Equations (3), (4), (6)* indicates the damping resistor variable $R2$ could be chosen to compensate the “ ω ” terms for the phase margin. This implies that another resistor of equal value to $R2$ will need to be switched in parallel with $R2$ during the initial lock period. We must also ensure that the magnitude of the open loop gain, $H(s)G(s)$ is equal to zero at $\omega_p' = 2\omega_p$. K_{VCO} , K_ϕ , N , or the net product of these terms can be changed by a factor of 4, to counteract the ω^2 term present in the denominator of *Equations (3), (4)*. The K_ϕ term was chosen to complete the transformation because it can readily be switch between 1X and 4X values. This is accomplished by increasing the charge pump output current from 1 mA in the standard mode to 4 mA in Fastlock.

Application Information (Continued)

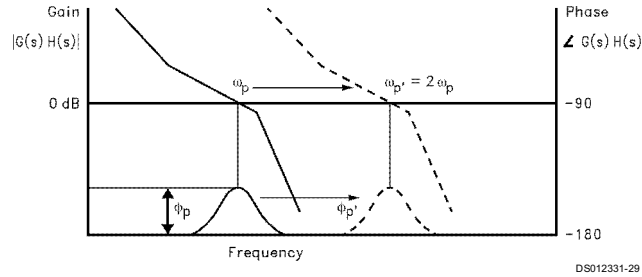

FIGURE 4. Open Loop Response Bode Plot

FASTLOCK CIRCUIT IMPLEMENTATION

A diagram of the Fastlock scheme as implemented in National Semiconductors LMX233xA PLL is shown in *Figure 5*. When a new frequency is loaded, and the RF lcp_o bit is set high the charge pump circuit receives an input to deliver 4 times the normal current per unit phase error while an open drain NMOS on chip device switches in a second R2 resistor element to ground. The user calculates the loop filter component values for the normal steady state considerations. The device configuration ensures that as long as a second iden-

tical damping resistor is wired in appropriately, the loop will lock faster without any additional stability considerations to account for. Once locked on the correct frequency, the user can return the PLL to standard low noise operation by sending a MICROWIRE instruction with the RF lcp_o bit set low. This transition does not affect the charge on the loop filter capacitors and is enacted synchronous with the charge pump output. This creates a nearly seamless change between Fastlock and standard mode.

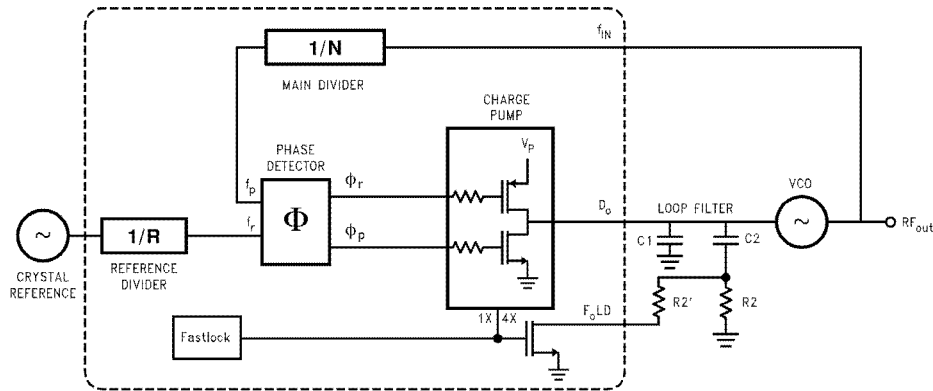
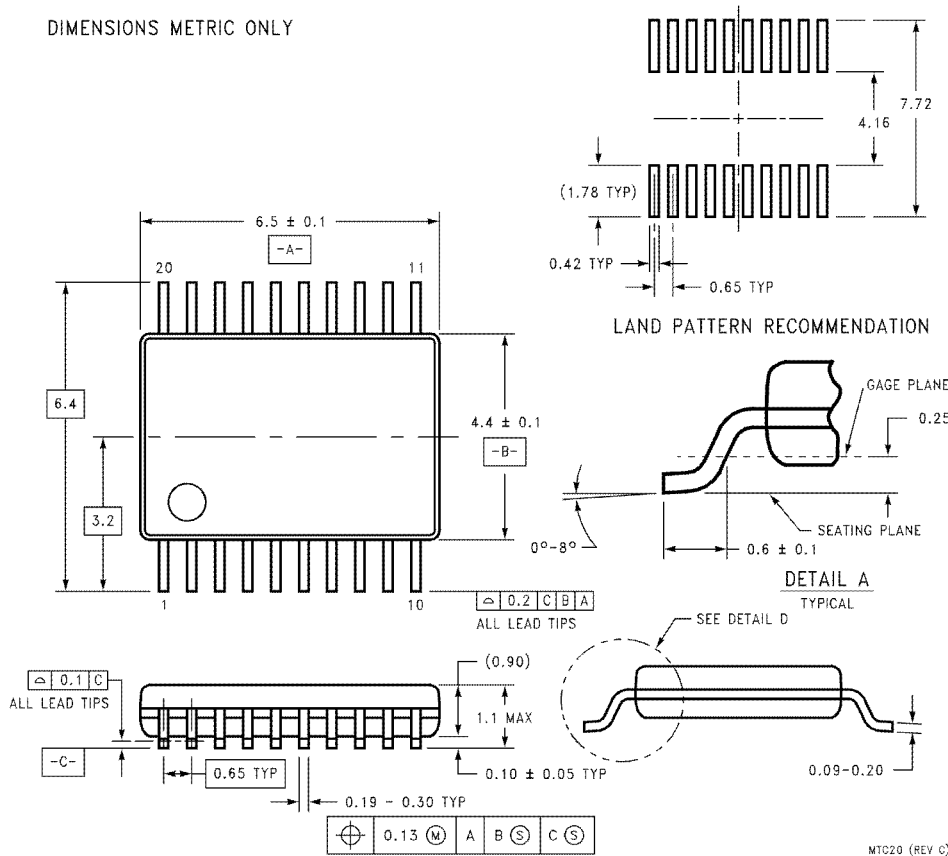

FIGURE 5. Fastlock PLL Architecture

Physical Dimensions inches (millimeters) unless otherwise noted

DIMENSIONS METRIC ONLY



20-Lead (0.173" Wide) Thin Shrink Small Outline Package (TM)
Order Number LMX2330ATM, LMX2331ATM or LMX2332ATM
 * For Tape and Reel (2500 units per reel)
Order Number LMX2330ATMX, LMX2331ATMX or LMX2332ATMX
NS Package Number MTC20

LIFE SUPPORT POLICY

NATIONAL'S PRODUCTS ARE NOT AUTHORIZED FOR USE AS CRITICAL COMPONENTS IN LIFE SUPPORT DEVICES OR SYSTEMS WITHOUT THE EXPRESS WRITTEN APPROVAL OF THE PRESIDENT AND GENERAL COUNSEL OF NATIONAL SEMICONDUCTOR CORPORATION. As used herein:

- Life support devices or systems are devices or systems which, (a) are intended for surgical implant into the body, or (b) support or sustain life, and whose failure to perform when properly used in accordance with instructions for use provided in the labeling, can be reasonably expected to result in a significant injury to the user.
- A critical component is any component of a life support device or system whose failure to perform can be reasonably expected to cause the failure of the life support device or system, or to affect its safety or effectiveness.

National Semiconductor Corporation
 Americas
 Tel: 1-800-272-9959
 Fax: 1-800-737-7018
 Email: support@nsc.com
 www.national.com

National Semiconductor Europe
 Fax: +49 (0) 1 80-530 85 86
 Email: europe.support@nsc.com
 Deutsch Tel: +49 (0) 1 80-530 85 85
 English Tel: +49 (0) 1 80-532 78 32
 Français Tel: +49 (0) 1 80-532 93 58
 Italiano Tel: +49 (0) 1 80-534 16 80

National Semiconductor Asia Pacific Customer Response Group
 Tel: 65-2544466
 Fax: 65-2504466
 Email: sea.support@nsc.com

National Semiconductor Japan Ltd.
 Tel: 81-3-5639-7560
 Fax: 81-3-5639-7507