

KA334

Dual Power Operational Amplifier

Features

- Output Current upto 0.7A
- Operates at Low Voltage ($V_{S(MIN)}=4V$)
- Low Saturation Voltage ($I_p=0.5A, V_O=1.5V$)
- Thermal Shutdown (TSD=160°C)
- Ground Compatible Inputs
- Large Common mode & Differential mode Range

Applications

- Servo Amplifier
- Power Supply
- Compact Disc
- VCR
- Monitor

Description

The KA334 is a high-power dual operational amplifier provided as a 8-DIP and 16-SOP package. The operational amplifier is designed for low impedance loads and will deliver output current upto 0.7A. The KA334 can be used in a wide range of applications including power supply, VCR, monitor, servo amplifier, compact disc, etc

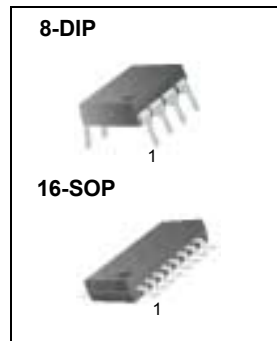

Internal Block Diagram

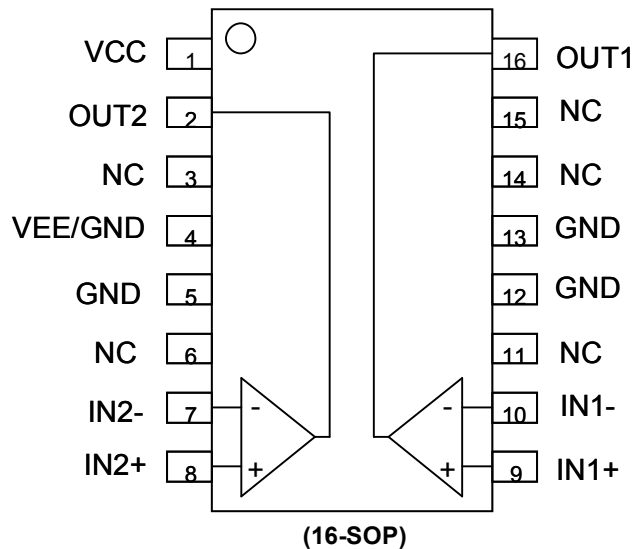
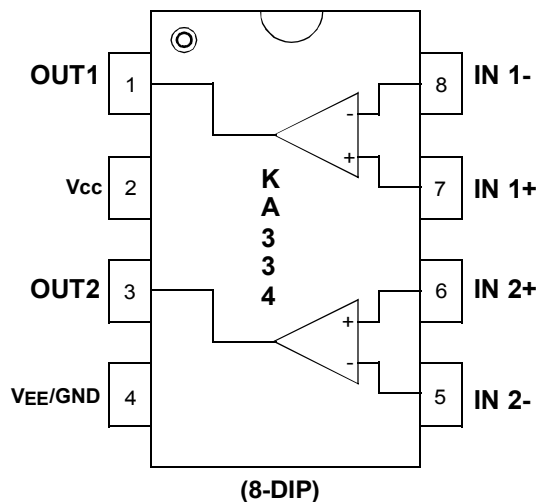

PIN Definitions

Pin Number		Pin Name	Pin Function Description
8-DIP	16-SOP		
1	16	OUTPUT1	Amp Output 1
2	1	VCC	Positive Supply Voltage
3	2	OUTPUT2	Amp Output 2
4	4/5/12/13	VEE/GND	Negative Supply Voltage (GND)
5	7	INPUT-2	Amp Negative Input 2
6	8	INPUT+2	Amp Positive Input 2
7	9	INPUT+1	Amp Positive Input 1
8	10	INPUT-1	Amp Negative Input 1

Absolute Maximum Ratings

Parameter	Symbol	Value	Unit
Supply Voltage	VCC	40	V
Input Voltage	VI	VS	V
Differential Input Voltage	VI(DIFF)	±VS	V
DC Output Current	IO	0.7	A
Peak Output Current (non repetitive)	IP	1	A
Power dissipation at: Tamb=50°C	Ptot	1	W
Operating Temperature Range	Top	-25 to 85	°C
Storage and Junction Temperature	Tstg, Tj	-40 to 150	°C

Thermal Data

Parameter	Symbol	Value	Unit
Thermal Resistance Junction-Ambient Max. 8-DIP 16-SOP	Rθja	100 190	°C/W

Electrical Characteristics

($V_{CC} = +12V$, $V_{EE} = -12V$, $T_a = 25^{\circ}C$ unless otherwise specified)

Parameter	Symbol	Conditions	Min.	Typ.	Max.	Unit
Supply Voltage ($V_{CC} - V_{EE}$)	V_S		4	-	28	V
Supply Current	I_S	$V_O = V_{CC}/2$ $V_{CC}=24V, V_{EE}=0V$ $V_{CC}=12V, V_{EE}=0V$	-	8 7.5	12 11	mA mA
Input Bias Current	I_{BIAS}	-	-	0.3	2.5	μA
Input Offset Voltage	V_{IO}	-	-	15	60	mV
Input Offset Current	I_{IO}	-	-	50	250	nA
Slew Rate	SR	$V_{in} = 1V_{pp}$, Unit Gain	-	1	-	V/ μs
Gain-Bandwidth Product	GBW	-	-	350	-	KHz
Input Resistance	R_I	-	500	-	-	K Ω
Large Signal	G_V	$V_{O(pp)} = \pm 10V$	65	75	-	dB
Input Noise Voltage	e_N	$B = 20KHz$	-	10	-	μV
Input Noise Current	I_N	$B = 20KHz$	-	200	-	pA
Common Mode Rejection Ratio	CMRR	-	60	75	-	dB
Supply Voltage Rejection Ratio	PSRR	$V_{CC} = +15V, V_{EE} = -15V$ $V_{CC} = +5V, V_{EE} = -5V$	54	62	-	dB
Output Voltage Swing	V_O	$V_{CC} = 24V, V_{EE} = 0V$ $I_p = 0.1A$ $I_p = 0.5A$	21 21	23 22.5	- -	V V
Channel Separation	C_S	$f = 1kHz; R_L = 10\Omega,$ $G_V = 30dB$	-	60	-	dB
Total Harmonic Distortion	THD	$f = 1kHz, G_V = 1dB, R_L = \infty$	-	0.5	-	%
Thermal shutdown Temperature (Note1)	TSD	-	-	160	-	$^{\circ}C$

Note :

1. Guaranteed by design. Not 100% tested in production.

Typical Performance Characteristics

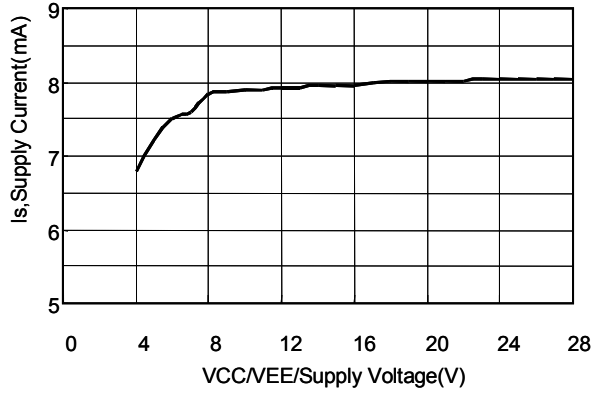

Figure 1. Supply Voltage vs Supply Current with No Load

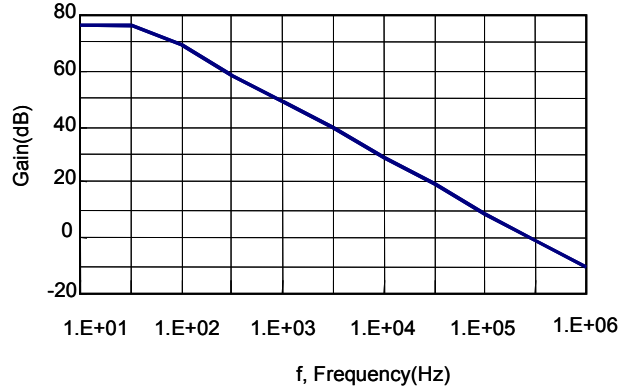

Figure 2. Open Loop Voltage Gain

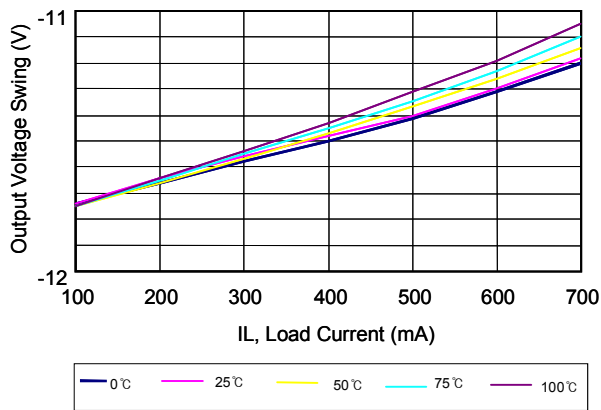

Figure 3-1. Output Voltage Swing vs Load Current

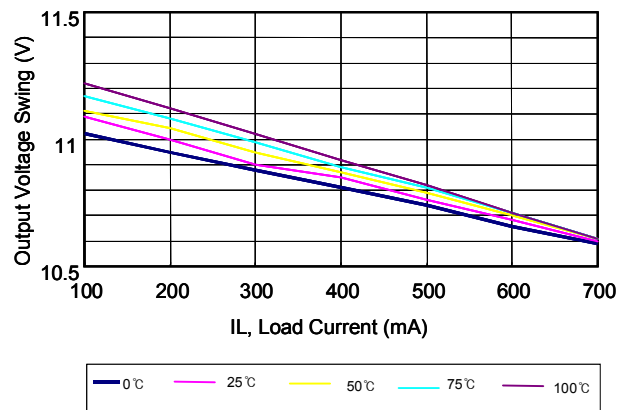

Figure 3-2. Output Voltage Swing vs Load Current

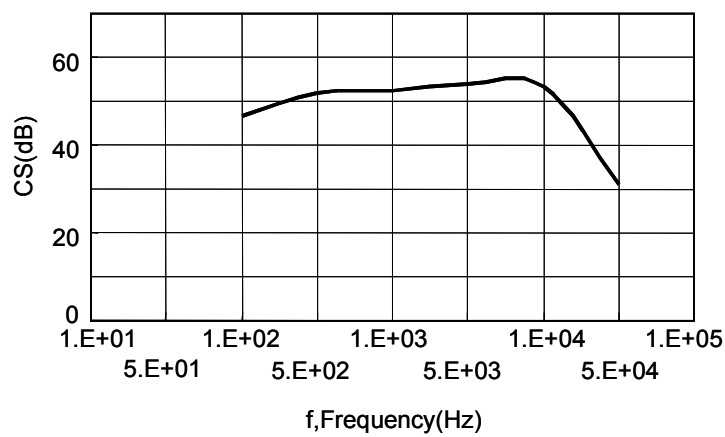
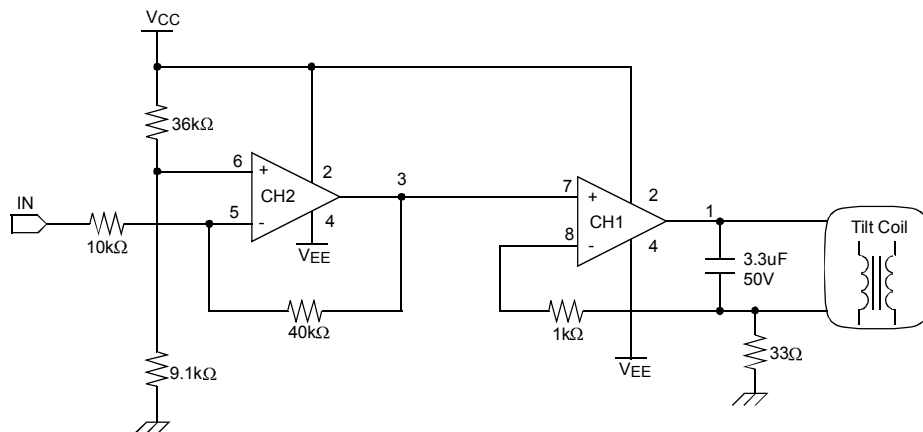

Figure 6. Channel Separation vs Frequency

Applications



< Tilt Coil Current Control Circuit in Monitor, 8-DIP Package >

Mechanical Dimensions

Package

Dimensions in millimeters

8-DIP

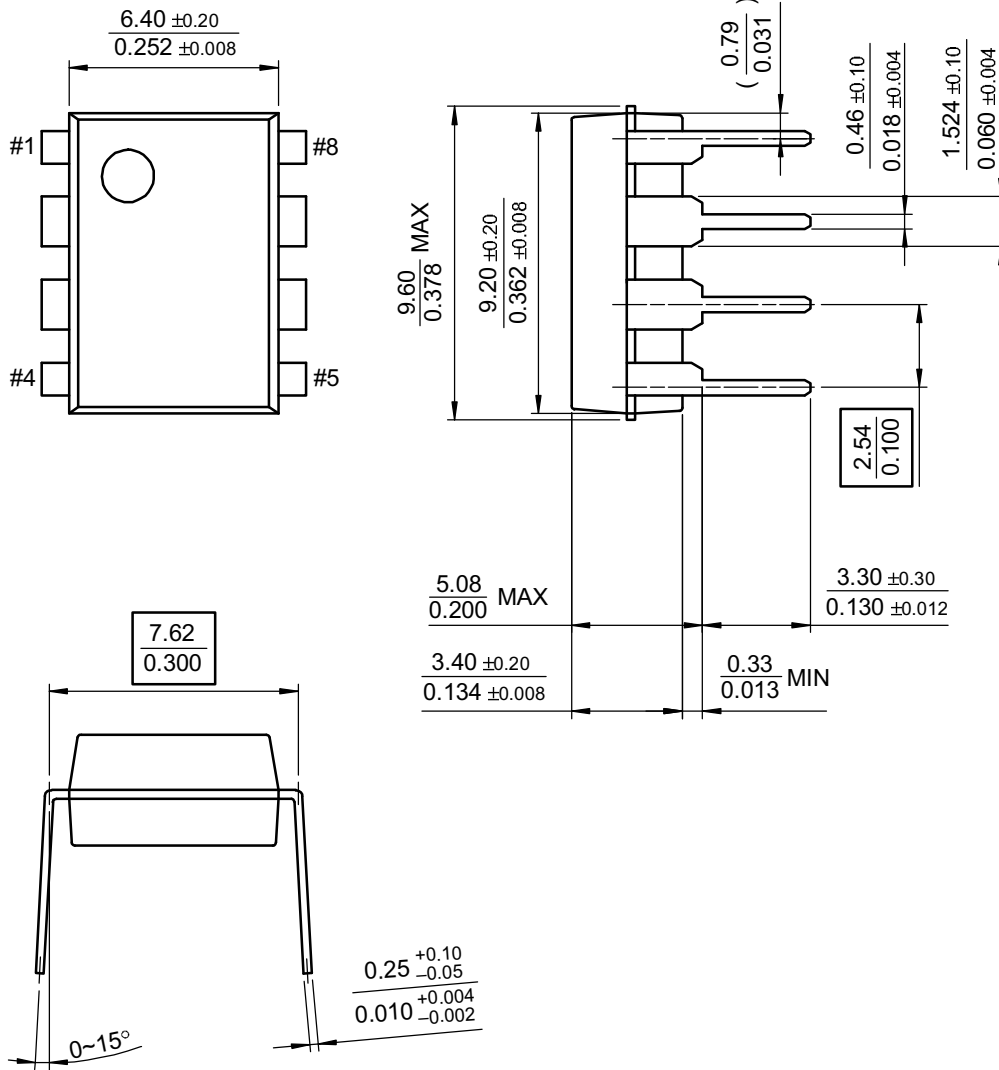

Mechanical Dimensions

Package

Dimensions in millimeters

16-SOP

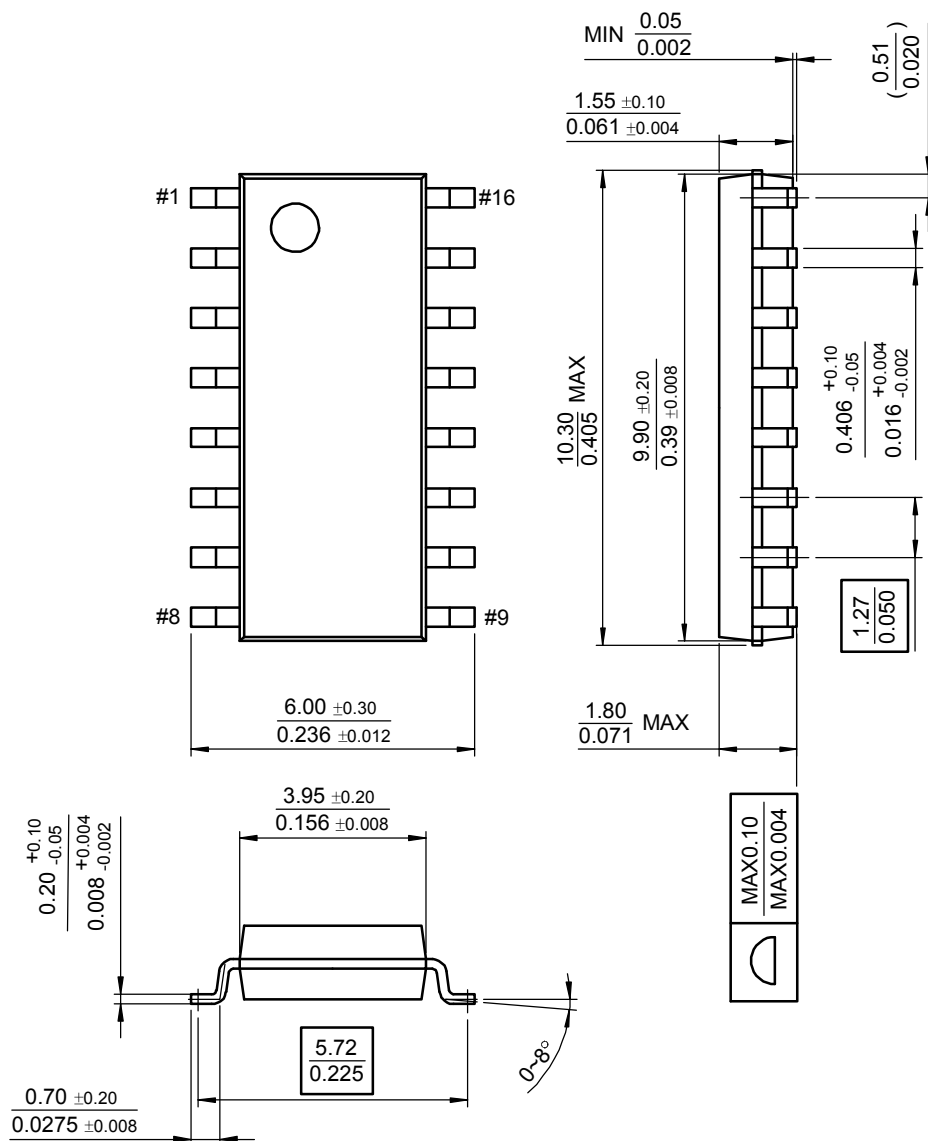

Ordering Information

Product Number	Package	Operating Temperature
KA334	8-DIP	-25°C ~ +85°C
KA334D	16-SOP	

DISCLAIMER

FAIRCHILD SEMICONDUCTOR RESERVES THE RIGHT TO MAKE CHANGES WITHOUT FURTHER NOTICE TO ANY PRODUCTS HEREIN TO IMPROVE RELIABILITY, FUNCTION OR DESIGN. FAIRCHILD DOES NOT ASSUME ANY LIABILITY ARISING OUT OF THE APPLICATION OR USE OF ANY PRODUCT OR CIRCUIT DESCRIBED HEREIN; NEITHER DOES IT CONVEY ANY LICENSE UNDER ITS PATENT RIGHTS, NOR THE RIGHTS OF OTHERS.

LIFE SUPPORT POLICY

FAIRCHILD'S PRODUCTS ARE NOT AUTHORIZED FOR USE AS CRITICAL COMPONENTS IN LIFE SUPPORT DEVICES OR SYSTEMS WITHOUT THE EXPRESS WRITTEN APPROVAL OF THE PRESIDENT OF FAIRCHILD SEMICONDUCTOR CORPORATION. As used herein:

1. Life support devices or systems are devices or systems which, (a) are intended for surgical implant into the body, or (b) support or sustain life, and (c) whose failure to perform when properly used in accordance with instructions for use provided in the labeling, can be reasonably expected to result in a significant injury of the user.
2. A critical component in any component of a life support device or system whose failure to perform can be reasonably expected to cause the failure of the life support device or system, or to affect its safety or effectiveness.