

**Document Title****256Kx16 bit Low Power and Low Voltage CMOS Static RAM****Revision History**

<b><u>Revision No</u></b>	<b><u>History</u></b>	<b><u>Draft Date</u></b>	<b><u>Remark</u></b>
0.0	Initial draft	January 13, 1998	Advance
0.1	Revise - Speed bin change Commercial: 70/85ns to 70/85/100ns Industrial: 85/100ns to 70/85/100ns - DC Characteristics change Icc: 5mA at read/write to 4mA at read Icc1: 5mA to 6mA Icc2: 50mA to 45mA Isb: 0.5mA to 0.3mA Isb1: 10µA to 15µA for commercial parts	June 12, 1998	Preliminary
0.11	Errata correction	August 13, 1998	
1.0	Finalize	November 16, 1998	Final
2.0	Revise - Add K6T4016V3C-TB55 product	June 26, 2001	Final
2.01	Revise - Improved VOH(output high voltage) from 2.2V to 2.4V.	October 15, 2001	Final

The attached datasheets are provided by SAMSUNG Electronics. SAMSUNG Electronics CO., LTD. reserve the right to change the specifications and products. SAMSUNG Electronics will answer to your questions about device. If you have any questions, please contact the SAMSUNG branch offices.

## 256Kx16 bit Low Power and Low Voltage CMOS Static RAM

### FEATURES

- Process Technology: TFT
- Organization: 256K x16
- Power Supply Voltage
  - K6T4016V3C Family: 3.0~3.6V
  - K6T4016U3C Family: 2.7~3.3V
- Low Data Retention Voltage: 2V(Min)
- Three State Outputs
- Package Type: 44-TSOP2-400F/R

### GENERAL DESCRIPTION

The K6T4016V3C and K6T4016U3C families are fabricated by SAMSUNG's advanced CMOS process technology. The families support various operating temperature ranges and have various package types for user flexibility of system design. The families also support low data retention voltage for battery back-up operation with low data retention current.

### PRODUCT FAMILY

Product Family	Operating Temperature	Vcc Range	Speed(ns)	Power Dissipation		PKG Type
				Standby (I <sub>SB1</sub> , Max)	Operating (I <sub>CC2</sub> , Max)	
K6T4016V3C-B	Commercial(0~70°C)	3.0~3.6V	55 <sup>1)</sup> /70 <sup>1)</sup> /85/100	15μA	45mA	44-TSOP2-400F/R
K6T4016U3C-B		2.7~3.3V				
K6T4016V3C-F	Industrial(-40~85°C)	3.0~3.6V	70 <sup>1)</sup> /85/100	20μA		
K6T4016U3C-F		2.7~3.3V				

1. The parameter is measured with 30pF test load.

### PIN DESCRIPTION

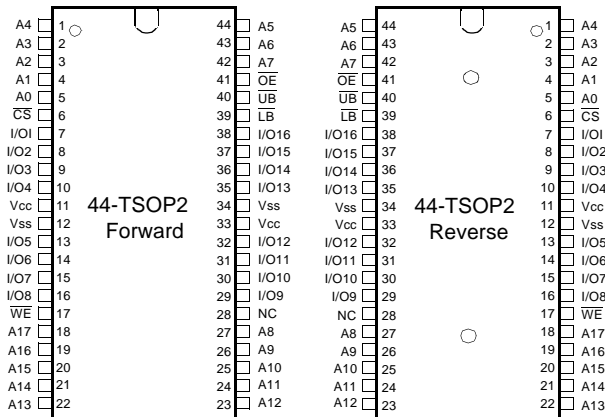

Name	Function	Name	Function
$\overline{CS}$	Chip Select Input	Vcc	Power
$\overline{OE}$	Output Enable Input	Vss	Ground
$\overline{WE}$	Write Enable Input	$\overline{LB}$	Lower Byte (I/O1-8)
A0~A17	Address Inputs	$\overline{UB}$	Upper Byte (I/O9-16)
I/O1~I/O16	Data Input/Output	NC	No Connection

### FUNCTIONAL BLOCK DIAGRAM

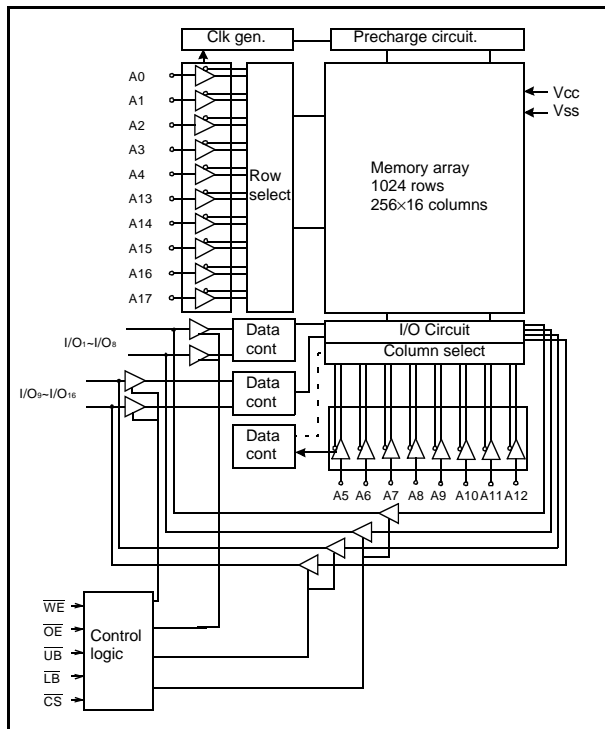

SAMSUNG ELECTRONICS CO., LTD. reserves the right to change products and specifications without notice.

## PRODUCT LIST

Commercial Temperature Product(0~70°C)		Industrial Temperature Products(-40~85°C)	
Part Name	Function	Part Name	Function
K6T4016V3C-TB55	44-TSOP2-F, 55ns, 3.3V, LL	K6T4016V3C-TF70	44-TSOP2-F, 70ns, 3.3V, LL
K6T4016V3C-TB70	44-TSOP2-F, 70ns, 3.3V, LL	K6T4016V3C-TF85	44-TSOP2-F, 85ns, 3.3V, LL
K6T4016V3C-TB85	44-TSOP2-F, 85ns, 3.3V, LL	K6T4016V3C-TF10	44-TSOP2-F, 100ns, 3.3V, LL
K6T4016V3C-TB10	44-TSOP2-F, 100ns, 3.3V, LL	K6T4016V3C-RF70	44-TSOP2-R, 70ns, 3.3V, LL
K6T4016V3C-RB70	44-TSOP2-R, 70ns, 3.3V, LL	K6T4016V3C-RF85	44-TSOP2-R, 85ns, 3.3V, LL
K6T4016V3C-RB85	44-TSOP2-R, 85ns, 3.3V, LL	K6T4016V3C-RF10	44-TSOP2-R, 100ns, 3.3V, LL
K6T4016V3C-RB10	44-TSOP2-R, 100ns, 3.3V, LL		
K6T4016U3C-TB70	44-TSOP2-F, 70ns, 3.0V, LL	K6T4016U3C-TF70	44-TSOP2-F, 70ns, 3.0V, LL
K6T4016U3C-TB85	44-TSOP2-F, 85ns, 3.0V, LL	K6T4016U3C-TF85	44-TSOP2-F, 85ns, 3.0V, LL
K6T4016U3C-TB10	44-TSOP2-F, 100ns, 3.0V, LL	K6T4016U3C-TF10	44-TSOP2-F, 100ns, 3.0V, LL
K6T4016U3C-RB70	44-TSOP2-R, 70ns, 3.0V, LL	K6T4016U3C-RF70	44-TSOP2-R, 70ns, 3.0V, LL
K6T4016U3C-RB85	44-TSOP2-R, 85ns, 3.0V, LL	K6T4016U3C-RF85	44-TSOP2-R, 85ns, 3.0V, LL
K6T4016U3C-RB10	44-TSOP2-R, 100ns, 3.0V, LL	K6T4016U3C-RF10	44-TSOP2-R, 100ns, 3.0V, LL

## FUNCTIONAL DESCRIPTION

CS	OE	WE	LB	UB	I/O <sub>1-8</sub>	I/O <sub>9-16</sub>	Mode	Power
H	X <sup>1)</sup>	X <sup>1)</sup>	X <sup>1)</sup>	X <sup>1)</sup>	High-Z	High-Z	Deselected	Standby
L	H	H	X <sup>1)</sup>	X <sup>1)</sup>	High-Z	High-Z	Output Disabled	Active
L	X <sup>1)</sup>	X <sup>1)</sup>	H	H	High-Z	High-Z	Output Disabled	Active
L	L	H	L	H	Dout	High-Z	Lower Byte Read	Active
L	L	H	H	L	High-Z	Dout	Upper Byte Read	Active
L	L	H	L	L	Dout	Dout	Word Read	Active
L	X <sup>1)</sup>	L	L	H	Din	High-Z	Lower Byte Write	Active
L	X <sup>1)</sup>	L	H	L	High-Z	Din	Upper Byte Write	Active
L	X <sup>1)</sup>	L	L	L	Din	Din	Word Write	Active

1. X means don't care. (Must be in low or high state)

## ABSOLUTE MAXIMUM RATINGS<sup>1)</sup>

Item	Symbol	Ratings	Unit	Remark
Voltage on any pin relative to Vss	V <sub>IN</sub> , V <sub>OUT</sub>	-0.5 to V <sub>CC</sub> +0.5	V	-
Voltage on Vcc supply relative to Vss	V <sub>CC</sub>	-0.3 to 4.6	V	-
Power Dissipation	P <sub>D</sub>	1.0	W	-
Storage temperature	T <sub>STG</sub>	-65 to 150	°C	-
Operating Temperature	T <sub>A</sub>	0 to 70	°C	K6T4016V3C-B, K6T4016U3C-B
		-40 to 85	°C	K6T4016V3C-F, K6T4016U3C-F

1. Stresses greater than those listed under "Absolute Maximum Ratings" may cause permanent damage to the device. Functional operation should be restricted to recommended operating condition. Exposure to absolute maximum rating conditions for extended periods may affect reliability.

## RECOMMENDED DC OPERATING CONDITIONS<sup>1)</sup>

Item	Symbol	Product	Min	Typ	Max	Unit
Supply voltage	V <sub>CC</sub>	K6T4016V3C Family K6T4016U3C Family	3.0 2.7	3.3 3.0	3.6 3.3	V
Ground	V <sub>SS</sub>	All Family	0	0	0	V
Input high voltage	V <sub>IH</sub>	K6T4016V3C, K6T4016U3C Family	2.2	-	V <sub>CC</sub> +0.3 <sup>2)</sup>	V
Input low voltage	V <sub>IL</sub>	K6T4016V3C, K6T4016U3C Family	-0.3 <sup>3)</sup>	-	0.6	V

Note:

- Commercial Product: T<sub>A</sub>=0 to 70°C, otherwise specified  
Industrial Product: T<sub>A</sub>=-40 to 85°C, otherwise specified
- Overshoot: V<sub>CC</sub>+2.0V in case of pulse width ≤ 30ns
- Undershoot: -2.0V in case of pulse width ≤ 30ns
- Overshoot and undershoot are sampled, not 100% tested.

## CAPACITANCE<sup>1)</sup> (f=1MHz, T<sub>A</sub>=25°C)

Item	Symbol	Test Condition	Min	Max	Unit
Input capacitance	C <sub>IN</sub>	V <sub>IN</sub> =0V	-	8	pF
Input/Output capacitance	C <sub>IO</sub>	V <sub>IO</sub> =0V	-	10	pF

- Capacitance is sampled, not 100% tested

## DC AND OPERATING CHARACTERISTICS

Item	Symbol	Test Conditions	Min	Typ	Max	Unit
Input leakage current	I <sub>LI</sub>	V <sub>IL</sub> =V <sub>SS</sub> to V <sub>CC</sub>	-1	-	1	μA
Output leakage current	I <sub>LO</sub>	$\overline{CS}$ =V <sub>IH</sub> or $\overline{OE}$ =V <sub>IH</sub> or $\overline{WE}$ =V <sub>IL</sub> V <sub>IO</sub> =V <sub>SS</sub> to V <sub>CC</sub>	-1	-	1	μA
Operating power supply current	I <sub>CC</sub>	I <sub>IO</sub> =0mA, $\overline{CS}$ =V <sub>IL</sub> , V <sub>IN</sub> =V <sub>IL</sub> or V <sub>IH</sub> , Read	-	-	4	mA
Average operating current	I <sub>CC1</sub>	Cycle time=1μs, 100% duty, I <sub>IO</sub> =0mA $\overline{CS}$ ≤0.2V, V <sub>IN</sub> ≤0.2V or V <sub>IN</sub> ≥V <sub>CC</sub> -0.2V	-	-	6	mA
	I <sub>CC2</sub>	Cycle time=Min <sup>2)</sup> , 100% duty, I <sub>IO</sub> =0mA, $\overline{CS}$ =V <sub>IL</sub> , V <sub>IN</sub> =V <sub>IH</sub> or V <sub>IL</sub>	-	-	45	mA
Output low voltage	V <sub>OL</sub>	I <sub>OL</sub> =2.1mA	-	-	0.4	V
Output high voltage	V <sub>OH</sub>	I <sub>OH</sub> =-1.0mA	2.4	-	-	V
Standby Current(TTL)	I <sub>SB</sub>	$\overline{CS}$ =V <sub>IH</sub> , Other inputs=V <sub>IL</sub> or V <sub>IH</sub>	-	-	0.3	mA
Standby Current(CMOS)	I <sub>SB1</sub>	$\overline{CS}$ ≥V <sub>CC</sub> -0.2V, Other inputs=0~V <sub>CC</sub>	-	-	15 <sup>1)</sup>	μA

- Industrial product = 20μA
- Cycle time = 70ns

## AC OPERATING CONDITIONS

### TEST CONDITIONS (Test Load and Input/Output Reference)

Input pulse level: 0.4 to 2.2V  
 Input rising and falling time: 5ns  
 Input and output reference voltage: 1.5V  
 Output load(see right):  $C_L=100\text{pF}+1\text{TTL}$   
 $C_L=30\text{pF}+1\text{TTL}$

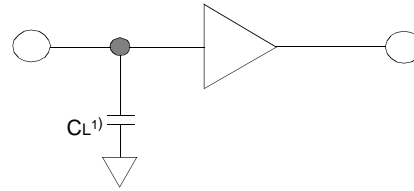

1. Including scope and jig capacitance

## AC CHARACTERISTICS (K6T4016V3C Family: $V_{CC}=3.0\sim 3.6\text{V}$ , K6T4016U3C Family: $V_{CC}=2.7\sim 3.3\text{V}$ Commercial product: $T_A=0$ to $70^\circ\text{C}$ , Industrial product: $T_A=-40$ to $85^\circ\text{C}$ )

Parameter List		Symbol	Speed Bins								Units
			55ns		70ns		85ns		100ns		
			Min	Max	Min	Max	Min	Max	Min	Max	
Read	Read cycle time	t <sub>RC</sub>	55	-	70	-	85	-	100	-	ns
	Address access time	t <sub>AA</sub>	-	55	-	70	-	85	-	100	ns
	Chip select to output	t <sub>CO</sub>	-	55	-	70	-	85	-	100	ns
	Output enable to valid output	t <sub>OE</sub>	-	25	-	35	-	40	-	50	ns
	$\overline{\text{LB}}$ , $\overline{\text{UB}}$ valid to data output	t <sub>BA</sub>	-	25	-	35	-	40	-	50	ns
	Chip select to low-Z output	t <sub>LZ</sub>	10	-	10	-	10	-	10	-	ns
	Output enable to low-Z output	t <sub>OLZ</sub>	5	-	5	-	5	-	5	-	ns
	$\overline{\text{LB}}$ , $\overline{\text{UB}}$ enable to low-Z output	t <sub>BLZ</sub>	5	-	5	-	5	-	5	-	ns
	Output hold from address change	t <sub>OH</sub>	10	-	10	-	10	-	15	-	ns
	Chip disable to high-Z output	t <sub>HZ</sub>	0	20	0	25	0	25	0	30	ns
	$\overline{\text{OE}}$ disable to high-Z output	t <sub>OHZ</sub>	0	20	0	25	0	25	0	30	ns
$\overline{\text{LB}}$ , $\overline{\text{UB}}$ disable to high-Z output	t <sub>BHZ</sub>	0	20	0	25	0	25	0	30	ns	
Write	Write cycle time	t <sub>WC</sub>	55	-	70	-	85	-	100	-	ns
	Chip select to end of write	t <sub>CW</sub>	45	-	60	-	70	-	80	-	ns
	Address set-up time	t <sub>AS</sub>	0	-	0	-	0	-	0	-	ns
	Address valid to end of write	t <sub>AW</sub>	45	-	60	-	70	-	80	-	ns
	Write pulse width	t <sub>WP</sub>	40	-	55	-	60	-	70	-	ns
	Write recovery time	t <sub>WR</sub>	0	-	0	-	0	-	0	-	ns
	Write to output high-Z	t <sub>WHZ</sub>	0	20	0	25	0	25	0	30	ns
	Data to write time overlap	t <sub>DW</sub>	25	-	30	-	35	-	40	-	ns
	Data hold from write time	t <sub>DH</sub>	0	-	0	-	0	-	0	-	ns
	End write to output low-Z	t <sub>OW</sub>	5	-	5	-	5	-	5	-	ns
$\overline{\text{LB}}$ , $\overline{\text{UB}}$ valid to end of write	t <sub>BW</sub>	45	-	60	-	70	-	80	-	ns	

## DATA RETENTION CHARACTERISTICS

Item	Symbol	Test Condition	Min	Typ	Max	Unit
V <sub>CC</sub> for data retention	V <sub>DR</sub>	$\overline{\text{CS}} \geq V_{CC}-0.2\text{V}$	2.0	-	3.6	V
Data retention current	I <sub>DR</sub>	$V_{CC}=3.0\text{V}$ , $\overline{\text{CS}} \geq V_{CC}-0.2\text{V}$	-	0.5	15 <sup>1)</sup>	μA
Data retention set-up time	t <sub>SDR</sub>	See data retention waveform	0	-	-	ms
Recovery time	t <sub>RDR</sub>		5	-	-	

1. Industrial product = 20μA



TIMING WAVEFORM OF WRITE CYCLE(1) ( $\overline{WE}$  Controlled)

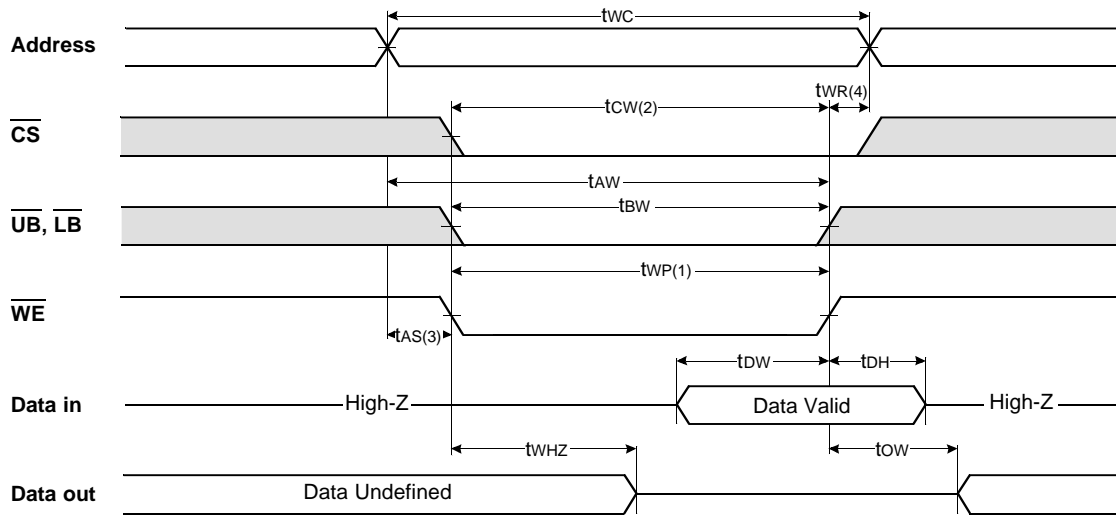

TIMING WAVEFORM OF WRITE CYCLE(2) ( $\overline{CS}$  Controlled)

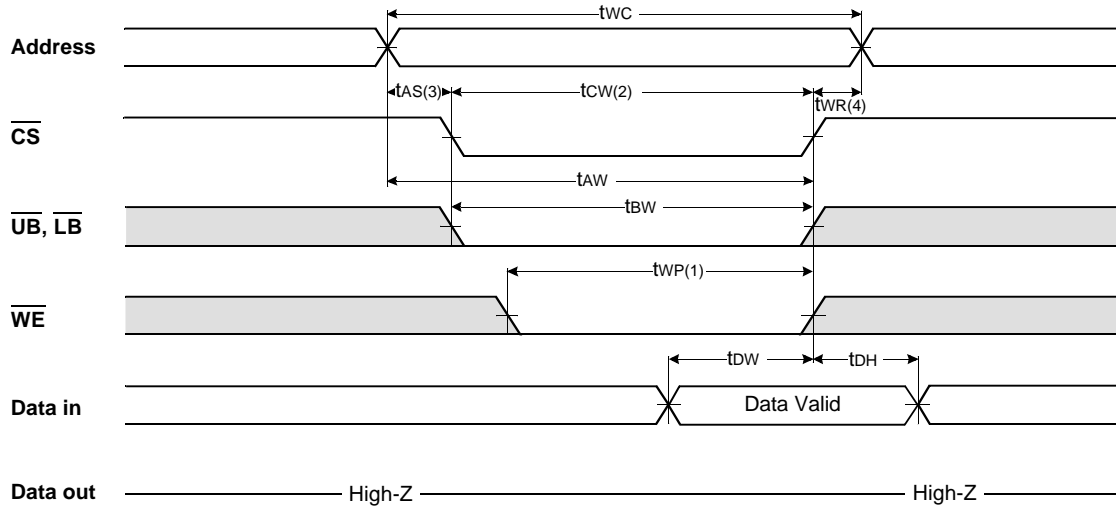

## TIMING WAVEFORM OF WRITE CYCLE(3) ( $\overline{UB}$ , $\overline{LB}$ Controlled)

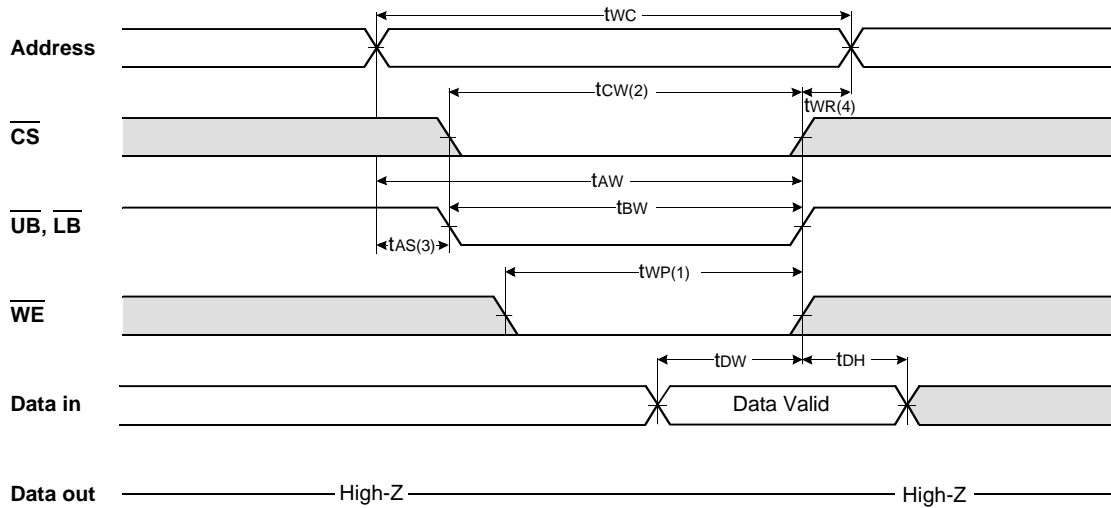

### NOTES (WRITE CYCLE)

1. A write occurs during the overlap( $t_{WP}$ ) of low  $\overline{CS}$  and low  $\overline{WE}$ . A write begins when  $\overline{CS}$  goes low and  $\overline{WE}$  goes low with asserting  $\overline{UB}$  or  $\overline{LB}$  for single byte operation or simultaneously asserting  $\overline{UB}$  and  $\overline{LB}$  for double byte operation. A write ends at the earliest transition when  $\overline{CS}$  goes high and  $\overline{WE}$  goes high. The  $t_{WP}$  is measured from the beginning of write to the end of write.
2.  $t_{CW}$  is measured from the  $\overline{CS}$  going low to the end of write.
3.  $t_{AS}$  is measured from the address valid to the beginning of write.
4.  $t_{WR}$  is measured from the end of write to the address change.  $t_{WR}$  is applied in case a write ends with  $\overline{CS}$  or  $\overline{WE}$  going high.

## DATA RETENTION WAVE FORM

### $\overline{CS}$ controlled

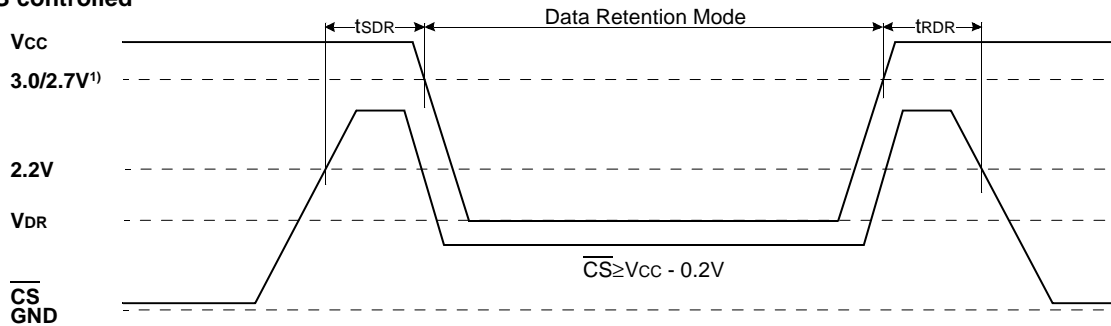

1. 3.0V for K6T4016V3C Family, 2.7V for K6T4016U3C Family

## PACKAGE DIMENSIONS

Unit: millimeter(inch)

### 44 PIN THIN SMALL OUTLINE PACKAGE TYPE II (400F)

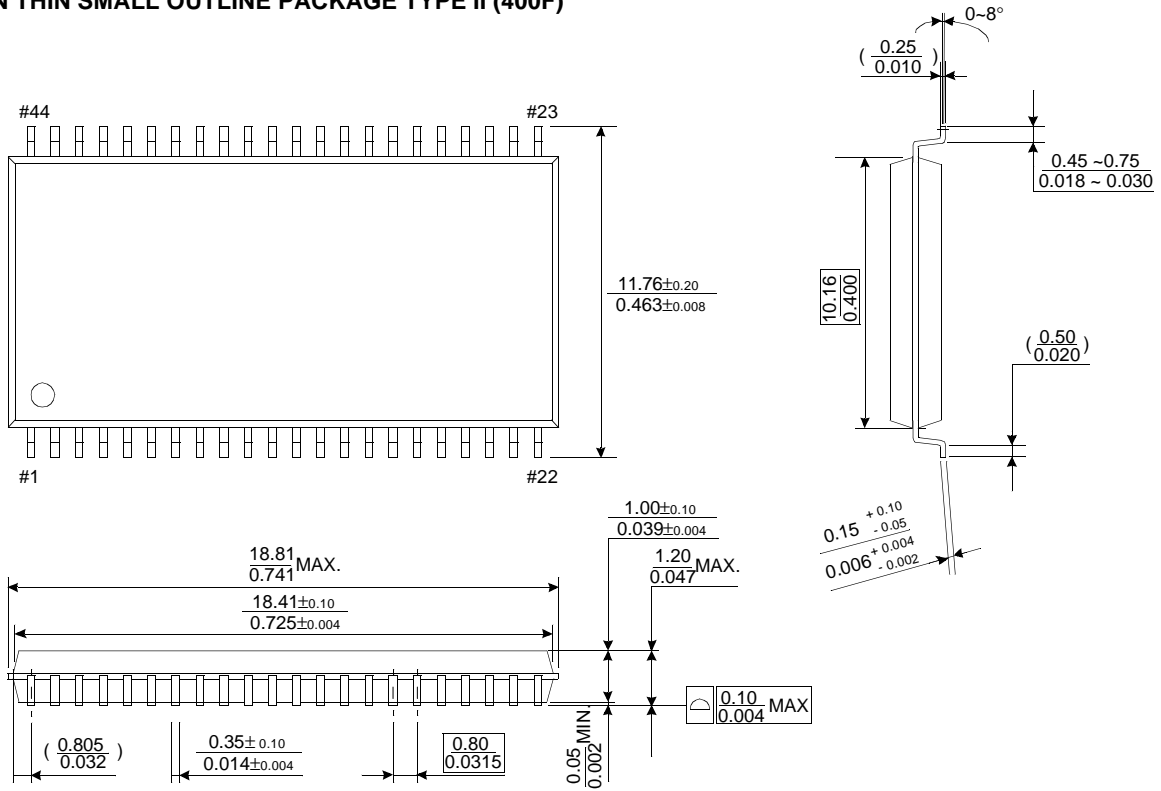

### 44 PIN THIN SMALL OUTLINE PACKAGE TYPE II (400R)

