

# 16Mb H-die SDRAM Specification

Revision 1.5

August 2004

Samsung Electronics reserves the right to change products or specification without notice.

## Revision History

### Revision 0.0 (May, 2003)

- Target spec release.

### Revision 0.1 (October, 2003)

- Modified tRDL from 1CLK to 2CLK.

### Revision 0.2 (October, 2003)

- Deleted AC parameter notes 5.

### Revision 0.3 (October, 2003)

- Modified tRDL & deleted speed 200MHz.

### Revision 1.0 (November, 2003)

- Revision 1.0 spec. release.

### Revision 1.1 (December, 2003)

- Corrected PKG dimension.

### Revision 1.2 (January, 2004)

- Deleted -10(10ns) speed.
- Modified load cap 50pF -> 30pF.
- Modified DC current .

### Revision 1.3 (January, 2004)

- Corrected typo

### Revision 1.4 (May, 2004)

- Added Note 8. sentence of tRDL parameter.

### Revision 1.5 (August, 2004)

- Modified CLK cycle time(tcc) parameter in AC Characteristics.  
( If you want use of CL=2 not CL=3, the maximum operating frequency is 100MHz regardless of its speed bin.)

**512K x 16Bit x 2 Banks SDRAM****FEATURES**

- 3.3V power supply
- LVTTTL compatible with multiplexed address
- two banks operation
- MRS cycle with address key programs
  - CAS Latency ( 2 & 3)
  - Burst Length (1, 2, 4, 8 & full page)
  - Burst Type (Sequential & Interleave)
- All inputs are sampled at the positive going edge of the system clock
- Burst Read Single-bit Write operation
- DQM for masking
- Auto & self refresh
- 32ms refresh period (2K cycle)

**GENERAL DESCRIPTION**

The K4S161622H is 16,777,216 bits synchronous high data rate Dynamic RAM organized as 2 x 524,288 words by 16 bits, fabricated with SAMSUNG's high performance CMOS technology. Synchronous design allows precise cycle control with the use of system clock I/O transactions are possible on every clock cycle. Range of operating frequencies, programmable burst length and programmable latencies allow the same device to be useful for a variety of high bandwidth, high performance memory system applications.

**ORDERING INFORMATION**

Part NO.	MAX Freq.	Interface	Package
K4S161622H-TC55	183MHz	LVTTTL	50pin TSOP(II)
K4S161622H-TC60	166MHz		
K4S161622H-TC70	143MHz		
K4S161622H-TC80	125MHz		

Organization	Row Address	Column Address
1Mx16	A0~A10	A0-A7

Row & Column address configuration

Package Physical Dimension

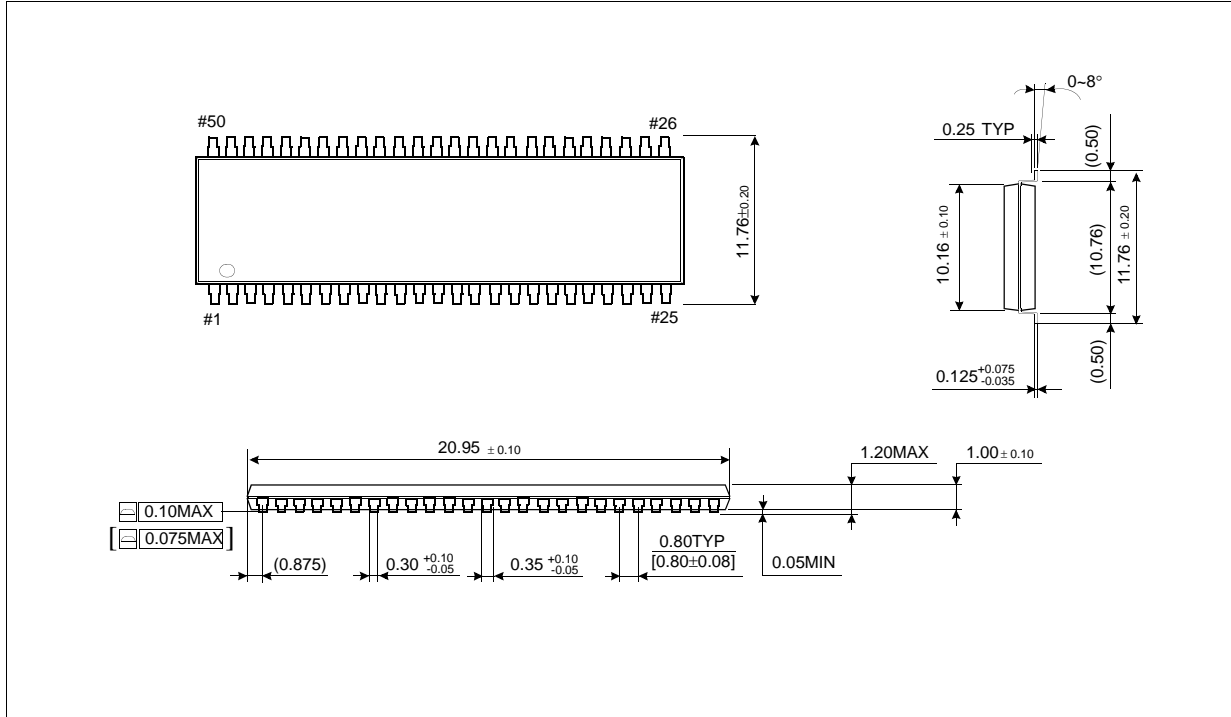

50Pin TSOP(II) Package Dimension

**FUNCTIONAL BLOCK DIAGRAM**

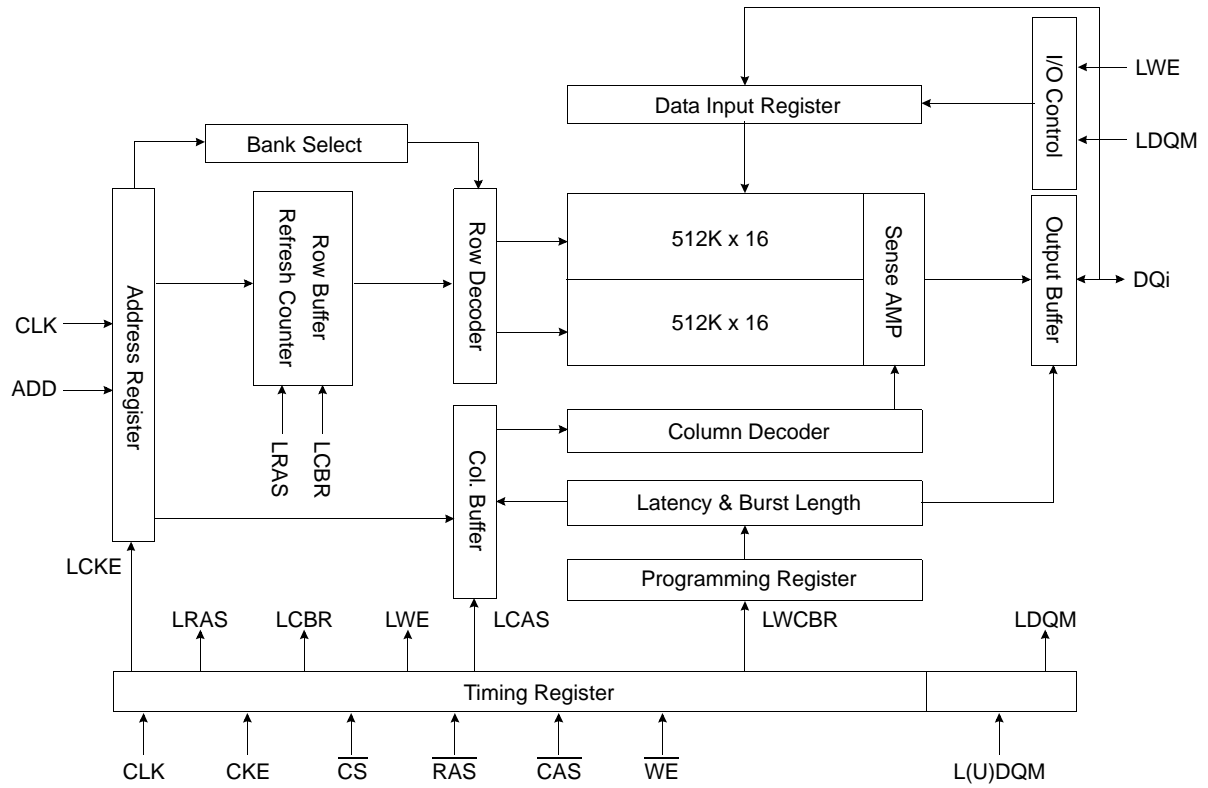

\* Samsung Electronics reserves the right to change products or specification without notice.

# SDRAM 16Mb H-die(x16)

# CMOS SDRAM

## PIN CONFIGURATION (TOP VIEW)

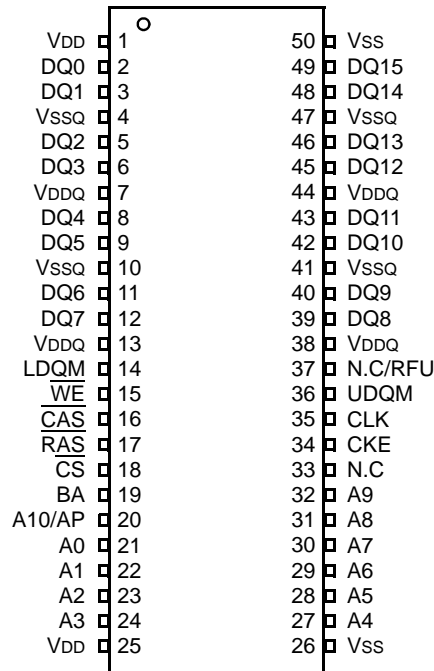

50PIN TSOP (II)  
(400mil x 825mil)  
(0.8 mm PIN PITCH)

## PIN FUNCTION DESCRIPTION

Pin	Name	Input Function
CLK	<i>System Clock</i>	Active on the positive going edge to sample all inputs.
$\overline{CS}$	<i>Chip Select</i>	Disables or enables device operation by masking or enabling all inputs except CLK, CKE and L(U)DQM
CKE	<i>Clock Enable</i>	Masks system clock to freeze operation from the next clock cycle. CKE should be enabled at least one cycle prior to new command. Disable input buffers for power down in standby.
A <sub>0</sub> ~ A <sub>10/AP</sub>	<i>Address</i>	Row / column addresses are multiplexed on the same pins. Row address : RA <sub>0</sub> ~ RA <sub>10</sub> , column address : CA <sub>0</sub> ~ CA <sub>7</sub>
BA	<i>Bank Select Address</i>	Selects bank to be activated during row address latch time. Selects bank for read/write during column address latch time.
$\overline{RAS}$	<i>Row Address Strobe</i>	Latches row addresses on the positive going edge of the CLK with $\overline{RAS}$ low. Enables row access & precharge.
$\overline{CAS}$	<i>Column Address Strobe</i>	Latches column addresses on the positive going edge of the CLK with $\overline{CAS}$ low. Enables column access.
$\overline{WE}$	<i>Write Enable</i>	Enables write operation and row precharge. Latches data in starting from $\overline{CAS}$ , $\overline{WE}$ active.
L(U)DQM	<i>Data Input/Output Mask</i>	Makes data output Hi-Z, tSHZ after the clock and masks the output. Blocks data input when L(U)DQM active.
DQ <sub>0</sub> ~ 15	<i>Data Input/Output</i>	Data inputs/outputs are multiplexed on the same pins.
VDD/VSS	<i>Power Supply/Ground</i>	Power and ground for the input buffers and the core logic.
VDDQ/VSSQ	<i>Data Output Power/Ground</i>	Isolated power supply and ground for the output buffers to provide improved noise immunity.
N.C/RFU	<i>No Connection/ Reserved for Future Use</i>	This pin is recommended to be left No Connection on the device.

## ABSOLUTE MAXIMUM RATINGS

Parameter	Symbol	Value	Unit
Voltage on any pin relative to Vss	V <sub>IN</sub> , V <sub>OUT</sub>	-1.0 ~ 4.6	V
Voltage on VDD supply relative to Vss	VDD, VDDQ	-1.0 ~ 4.6	V
Storage temperature	T <sub>STG</sub>	-55 ~ +150	°C
Power dissipation	P <sub>D</sub>	1	W
Short circuit current	I <sub>OS</sub>	50	mA

**Note :** Permanent device damage may occur if ABSOLUTE MAXIMUM RATINGS are exceeded.  
Functional operation should be restricted to recommended operating condition.  
Exposure to higher than recommended voltage for extended periods of time could affect device reliability.

## DC OPERATING CONDITIONS

Recommended operating conditions (Voltage referenced to Vss = 0V, T<sub>A</sub> = 0 to 70°C)

Parameter	Symbol	Min	Typ	Max	Unit	Note
Supply voltage	VDD, VDDQ	3.0	3.3	3.6	V	
Input logic high voltage	V <sub>IH</sub>	2.0	3.0	VDDQ+0.3	V	1
Input logic low voltage	V <sub>IL</sub>	-0.3	0	0.8	V	2
Output logic high voltage	V <sub>OH</sub>	2.4	-	-	V	I <sub>OH</sub> = -2mA
Output logic low voltage	V <sub>OL</sub>	-	-	0.4	V	I <sub>OL</sub> = 2mA
Input leakage current	I <sub>LI</sub>	-10	-	10	uA	3

**Note :** 1. V<sub>IH</sub> (max) = 5.6V AC. The overshoot voltage duration is ≤ 3ns.  
2. V<sub>IL</sub> (min) = -2.0V AC. The undershoot voltage duration is ≤ 3ns.  
3. Any input 0V ≤ V<sub>IN</sub> ≤ VDDQ.  
Input leakage currents include HI-Z output leakage for all bi-directional buffers with Tri-State outputs.

CAPACITANCE (VDD = 3.3V, T<sub>A</sub> = 23°C, f = 1MHz, VREF = 1.4V ± 200 mV)

Pin	Symbol	Min	Max	Unit
Clock	CCLK	2	4	pF
$\overline{\text{RAS}}$ , $\overline{\text{CAS}}$ , $\overline{\text{WE}}$ , $\overline{\text{CS}}$ , $\overline{\text{CKE}}$ , L(U)DQM	C <sub>IN</sub>	2	4	pF
Address	C <sub>ADD</sub>	2	4	pF
DQ <sub>0</sub> ~ DQ <sub>15</sub>	C <sub>OUT</sub>	3	5	pF

## DC CHARACTERISTICS

(Recommended operating condition unless otherwise noted, T<sub>A</sub> = 0 to 70°C )

Parameter	Symbol	Test Condition	Version				Unit	Note
			55	60	70	80		
Operating Current (One Bank Active)	I <sub>CC1</sub>	Burst Length =1 t <sub>RC</sub> ≥ t <sub>RC</sub> (min) I <sub>o</sub> = 0 mA	120	115	105	95	mA	2
Precharge Standby Current in power-down mode	I <sub>CC2P</sub>	CKE ≤ V <sub>IL</sub> (max), t <sub>CC</sub> = 10ns	2				mA	
	I <sub>CC2PS</sub>	CKE & CLK ≤ V <sub>IL</sub> (max), t <sub>CC</sub> = ∞	2					
Precharge Standby Current in non power-down mode	I <sub>CC2N</sub>	CKE ≥ V <sub>IH</sub> (min), $\overline{CS}$ ≥ V <sub>IH</sub> (min), t <sub>CC</sub> = 10ns Input signals are changed one time during 30ns	15				mA	
	I <sub>CC2NS</sub>	CKE ≥ V <sub>IH</sub> (min), CLK ≤ V <sub>IL</sub> (max), t <sub>CC</sub> = ∞ Input signals are stable	5					
Active Standby Current in power-down mode	I <sub>CC3P</sub>	CKE ≤ V <sub>IL</sub> (max), t <sub>CC</sub> = 10ns	3				mA	
	I <sub>CC3PS</sub>	CKE & CLK ≤ V <sub>IL</sub> (max), t <sub>CC</sub> = ∞	3					
Active Standby Current in non power-down mode (One Bank Active)	I <sub>CC3N</sub>	CKE ≥ V <sub>IH</sub> (min), $\overline{CS}$ ≥ V <sub>IH</sub> (min), t <sub>CC</sub> = 10ns Input signals are changed one time during 30ns	25				mA	
	I <sub>CC3NS</sub>	CKE ≥ V <sub>IH</sub> (min), CLK ≤ V <sub>IL</sub> (max), t <sub>CC</sub> = ∞ Input signals are stable	15					
Operating Current (Burst Mode)	I <sub>CC4</sub>	I <sub>o</sub> = 0 mA Page Burst 2Banks Activated t <sub>CCD</sub> = 2CLKs	155	150	140	130	mA	2
Refresh Current	I <sub>CC5</sub>	t <sub>RC</sub> ≥ t <sub>RC</sub> (min)	105	100	90	90	mA	3
Self Refresh Current	I <sub>CC6</sub>	CKE ≤ 0.2V	1				mA	

**Note** : 1. Unless otherwise notes, Input level is CMOS(V<sub>IH</sub>/V<sub>IL</sub>=V<sub>DDQ</sub>/V<sub>SSQ</sub>) in LVTTTL.

2. Measured with outputs open. Addresses are changed only one time during t<sub>CC</sub>(min).

3. Refresh period is 32ms. Addresses are changed only one time during t<sub>CC</sub>(min).

4. K4S161622H-TC

# SDRAM 16Mb H-die(x16)

# CMOS SDRAM

## AC OPERATING TEST CONDITIONS (V<sub>DD</sub> = 3.3V±0.3V, T<sub>A</sub> = 0 to 70°C)

Parameter	Value	Unit
Input levels (V <sub>ih</sub> /V <sub>il</sub> )	2.4 / 0.4	V
Input timing measurement reference level	1.4	V
Input rise and fall time	t <sub>r</sub> / t <sub>f</sub> = 1 / 1	ns
Output timing measurement reference level	1.4	V
Output load condition	See Fig. 2	

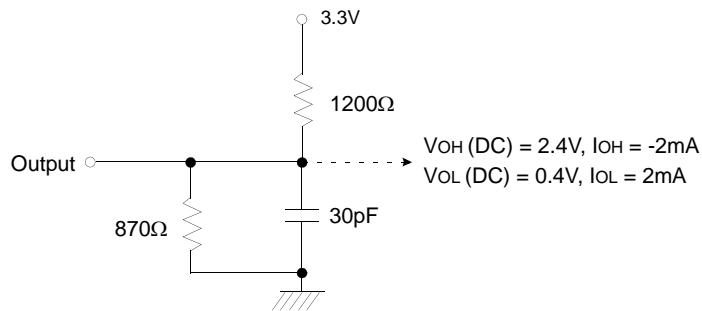

(Fig. 1) DC Output Load Circuit

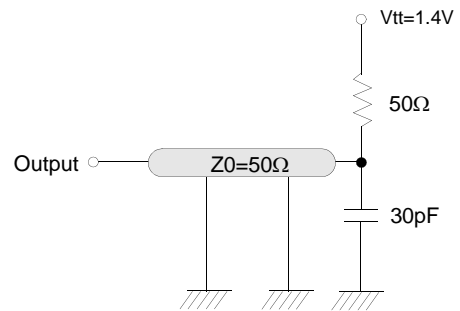

(Fig. 2) AC Output Load Circuit

## AC CHARACTERISTICS

(AC operating conditions unless otherwise noted)

Parameter	Symbol	55		60		70		80		Unit	Note
		Min	Max	Min	Max	Min	Max	Min	Max		
CLK cycle time	CAS Latency=3	5.5	1000	6	1000	7	1000	8	1000	ns	1
	CAS Latency=2	10		10		10		10			
Row active to row active delay	t <sub>RRD</sub> (min)	11	-	12	-	14	-	16	-	ns	
RAS to $\overline{\text{CAS}}$ delay	t <sub>RCD</sub> (min)	16.5	-	18	-	20	-	20	-	ns	
Row precharge time	t <sub>RP</sub> (min)	16.5	-	18	-	20	-	20	-	ns	
Row active time	t <sub>RAS</sub> (min)	38.5	-	42	-	49	-	48	-	ns	
	t <sub>RAS</sub> (max)	-	100	-	100	-	100	-	100	us	
Row cycle time	t <sub>RC</sub> (min)	55	-	60	-	69	-	70	-	ns	
Last data in to row precharge	t <sub>RDL</sub> (min)	2		<b>1</b>						CLK	2,8
Last data in to new col.address delay	t <sub>CDL</sub> (min)	1						CLK	2		
Last data in to burst stop	t <sub>BDL</sub> (min)	1						CLK	2		
Col. address to col. address delay	t <sub>CCD</sub> (min)	1						CLK			
Mode Register Set cycle time	t <sub>MRS</sub> (min)	2						CLK			
Number of valid output data	CAS Latency=3	2						ea	4		
	CAS Latency=2	1									

# SDRAM 16Mb H-die(x16)

# CMOS SDRAM

(AC operating conditions unless otherwise noted)

Parameter		Symbol	55		60		-70		-80		Unit	Note
			Min	Max	Min	Max	Min	Max	Min	Max		
CLK cycle time	CAS Latency=3	tCC	5.5	1000	6	1000	7	1000	8	1000	ns	5
	CAS Latency=2		10		10		10		10			
CLK to valid output delay	CAS Latency=3	tSAC	-	5	-	5.5	-	5.5	-	6	ns	5, 6
	CAS Latency=2		-	6	-	6	-	6	-	6		
Output data		tOH	2	-	2.5	-	2.5	-	2.5	-	ns	6
CLK high pulse width	CAS Latency=3	tCH	2	-	2.5	-	3	-	3	-	ns	7
	CAS Latency=2		3		3		3					
CLK low pulse width	CAS Latency=3	tCL	2	-	2.5	-	3	-	3	-	ns	7
	CAS Latency=2		3		3		3					
Input setup time	CAS Latency=3	tSS	1.5	-	1.5	-	1.75	-	2	-	ns	7
	CAS Latency=2		2		2		2					
Input hold time		tSH	1	-	1	-	1	-	1	-	ns	7
CLK to output in Low-Z		tSLZ	1	-	1	-	1	-	1	-	ns	6
CLK to output in Hi-Z	CAS Latency=3	tSHZ	-	5	-	5.5	-	5.5	-	6	ns	
	CAS Latency=2		-	6	-	6	-	6	-	6		

- Notes :**
- The minimum number of clock cycles is determined by dividing the minimum time required with clock cycle time and then rounding off to the next higher integer. Refer to the following clock unit based AC conversion table
  - Minimum delay is required to complete write.
  - All parts allow every cycle column address change.
  - In case of row precharge interrupt, auto precharge and read burst stop.
  - Parameters depend on programmed CAS latency.
  - If clock rising time is longer than 1ns,  $(tr/2-0.5)ns$  should be added to the parameter.
  - Assumed input rise and fall time ( $tr$  &  $tf$ )=1ns.  
If  $tr$  &  $tf$  is longer than 1ns, transient time compensation should be considered, i.e.,  $[(tr + tf)/2-1]ns$  should be added to the parameter.
  - In 100MHz and below 100MHz operating conditions,  $tRDL=1CLK$  and  $tDAL=1CLK + 20ns$  is also supported. SAMSUNG recommends  $tRDL=2CLK$  and  $tDAL=2CLK + tRP$ .

**SIMPLIFIED TRUTH TABLE**

COMMAND		CKEn-1	CKEn	$\overline{CS}$	$\overline{RAS}$	$\overline{CAS}$	$\overline{WE}$	DQM	BA	A10/AP	A9~ A0	Note
Register	Mode Register Set	H	X	L	L	L	L	X	OP CODE			1, 2
Refresh	Auto Refresh	H	H	L	L	L	H	X	X			3
	Entry		L									3
	Self Refresh	L	H	L	H	H	H	X	X			3
				Exit	H	X	X					3
Bank Active & Row Addr.		H	X	L	L	H	H	X	V	Row Address		
Read & Column Address	Auto Precharge Disable	H	X	L	H	L	H	X	V	L	Column Address	4
	Auto Precharge Enable									H		4, 5
Write & Column Address	Auto Precharge Disable	H	X	L	H	L	L	X	V	L	Column Address	4
	Auto Precharge Enable									H		4, 5
Burst Stop		H	X	L	H	H	L	X	X			6
Precharge	Bank Selection	H	X	L	L	H	L	X	V	L	X	
	Both Banks								X	H		
Clock Suspend or Active Power Down	Entry	H	L	H	X	X	X	X	X			
				L	V	V	V					
Precharge Power Down Mode	Entry	H	L	H	X	X	X	X	X			
				L	H	H	H					
	Exit	L	H	H	X	X	X	X				
				L	V	V	V					
DQM		H	X					V	X		7	
No Operation Command		H	X	H	X	X	X	X	X			
				L	H	H	H					

(V=Valid, X=Don't Care, H=Logic High, L=Logic Low)

**Note :** 1. OP Code : Operand Code

A0 ~ A10/AP, BA : Program keys. (@MRS)

2. MRS can be issued only at both banks precharge state.

A new command can be issued after 2 clock cycle of MRS.

3. Auto refresh functions are as same as CBR refresh of DRAM.

The automatical precharge without row precharge command is meant by "Auto".

Auto/self refresh can be issued only at both banks precharge state.

4. BA : Bank select address.

If "Low" at read, write, row active and precharge, bank A is selected.

If "High" at read, write, row active and precharge, bank B is selected.

If A10/AP is "High" at row precharge, BA is ignored and both banks are selected.

5. During burst read or write with auto precharge, new read/write command can not be issued.

Another bank read/write command can be issued after the end of burst.

New row active of the associated bank can be issued at tRP after the end of burst.

6. Burst stop command is valid at every burst length.

7. DQM sampled at positive going edge of a CLK masks the data-in at the very CLK (Write DQM latency is 0), but makes Hi-Z state the data-out of 2 CLK cycles after. (Read DQM latency is 2)