



ISP1301

Universal Serial Bus On-The-Go transceiver

Rev. 01 — 14 April 2004

Product data

1. General description

The ISP1301 is a Universal Serial Bus (USB) On-The-Go (OTG) transceiver device that is fully compliant with *Universal Serial Bus Specification Rev. 2.0* and *On-The-Go Supplement to the USB Specification Rev. 1.0a*. The ISP1301 can transmit and receive serial data at both full-speed (12 Mbit/s) and low-speed (1.5 Mbit/s) data rates.

It is ideal for use in portable electronics devices, such as mobile phones, digital still cameras, digital video cameras, Personal Digital Assistants (PDAs) and digital audio players. It allows USB Application Specific Integrated Circuits (ASICs), Programmable Logic Devices (PLDs) and any system chip set (with the USB host or device function built-in but without the USB physical layer) to interface to the physical layer of the USB.

The ISP1301 can interface to devices with digital I/O voltages in the range of 1.65 V to 3.6 V.

The ISP1301 is available in HVQFN24 package.

2. Features

- Fully complies with:
 - ◆ *Universal Serial Bus Specification Rev. 2.0*
 - ◆ *On-The-Go Supplement to the USB 2.0 Specification Rev. 1.0a*
 - ◆ *On-The-Go Transceiver Specification (CEA-2011) Rev. 1.0*
- Can transmit and receive serial data at both full-speed (12 Mbit/s) and low-speed (1.5 Mbit/s) data rates
- Ideal for system ASICs or chip sets with built-in USB OTG dual-role core
- Supports mini USB analog car kit interface
- Supports various serial data interface protocols; transparent general-purpose buffer mode allows you to control the direction of data transfer
- Supports data line and V_{BUS} pulsing session request
- Contains Host Negotiation Protocol (HNP) command and status registers
- Supports serial I²C-bus™ interface for OTG status and command controls
- 2.7 V to 4.5 V power supply input range for the ISP1301
- Built-in charge pump regulator outputs 5 V at current greater than 8 mA
- Supports external charge pump
- Supports wide range interfacing I/O voltage ($V_{DD_LGC} = 1.65\text{ V to }3.6\text{ V}$) for digital control logics



PHILIPS

- 8 kV built-in electrostatic discharge (ESD) protection on the DP, DM, V_{BUS} and ID lines
- Full industrial grade operation from –40 °C to +85 °C
- Available in a small HVQFN24 (4 × 4 mm²) halogen-free and lead-free package.

3. Applications

- Mobile phone
- Digital camera
- Personal digital assistant
- Digital video recorder.

4. Abbreviations

ASIC — Application-Specific Integrated Circuit
ATX — Analog USB transceiver
HNP — Host Negotiation Protocol
ESD — ElectroStatic Discharge
I²C-bus — Inter IC-bus
IC — Integrated Circuit
OTG — On-The-Go
PDA — Personal Digital Assistant
SE0 — Single-Ended zero
SOF — Start-of-Frame
SRP — Session Request Protocol
USB — Universal Serial Bus
USB-IF — USB Implementers Forum.

5. Ordering information

Table 1: Ordering information

Type number	Package		
	Name	Description	Version
ISP1301BS	HVQFN24	plastic thermal enhanced very thin quad flat package; no leads; 24 terminals; body 4 × 4 × 0.85 mm	SOT616-1

6. Block diagram

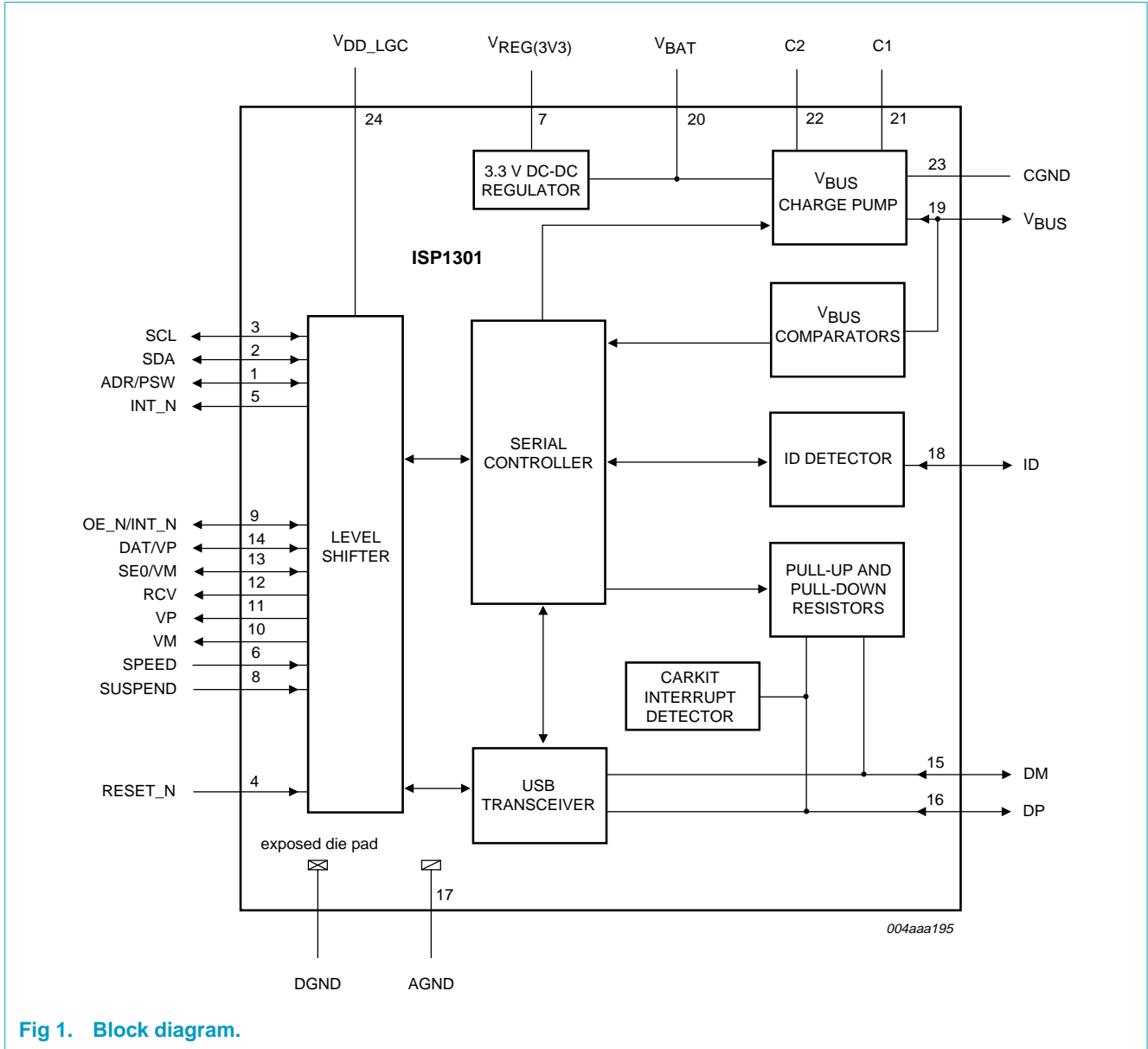
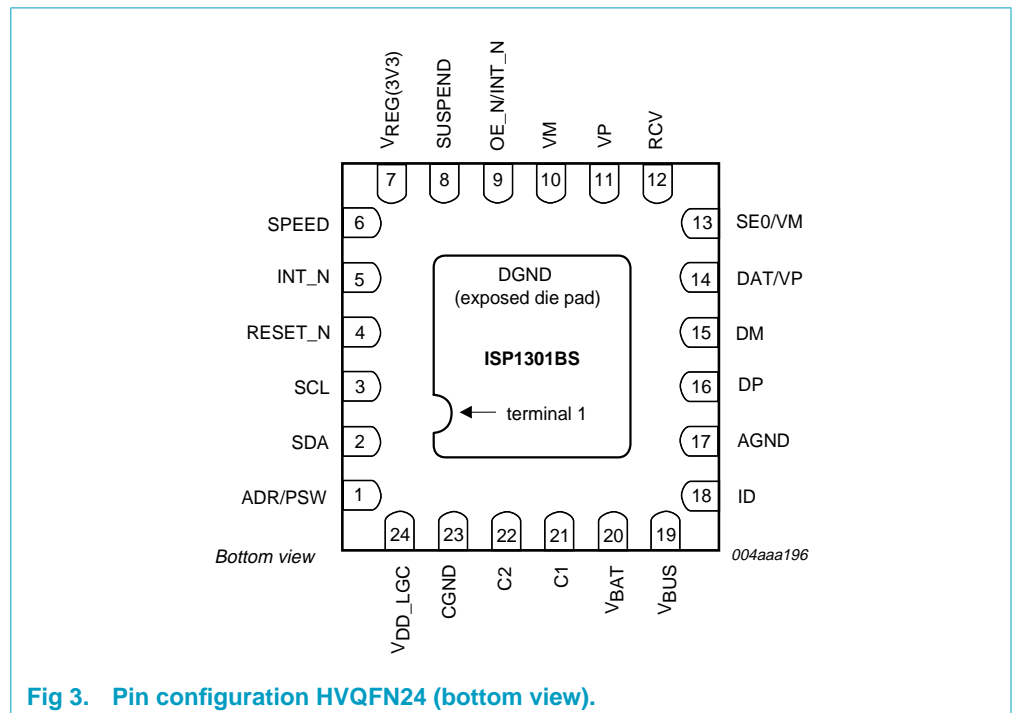
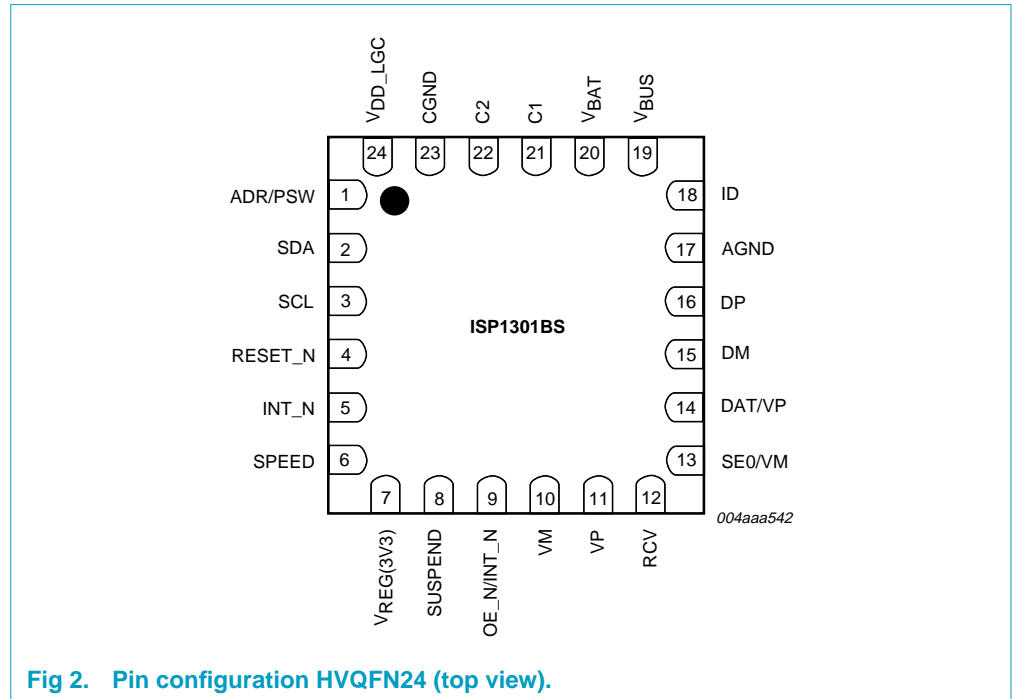

Fig 1. Block diagram.

7. Pinning information

7.1 Pinning



7.2 Pin description

Table 2: Pin description^[1]

Symbol ^[2]	Pin	Type ^[3]	Reset value	Description
ADR/PSW	1	I/O	high-Z	<p>ADR input — sets the least-significant I²C-bus address bit of the ISP1301; latched-on reset (including power-on reset)</p> <p>PSW output — enables or disables the external charge pump after reset</p> <p>bidirectional; push-pull input; three-state output</p>
SDA	2	I/OD	high-Z	<p>serial I²C-bus data input and output</p> <p>bidirectional; push-pull input; open-drain output</p>
SCL	3	I/OD	high-Z	<p>serial I²C-bus clock input and output</p> <p>bidirectional; push-pull input; open-drain output</p>
RESET_N	4	I	-	<p>asynchronous reset; active LOW</p> <p>push-pull input</p>
INT_N	5	OD	high-Z	<p>interrupt output; active LOW</p> <p>open-drain output</p>
SPEED	6	I	-	<p>speed selection input for the ATX; effective when bit SPD_SUSP_CTRL = 0:</p> <ul style="list-style-type: none"> • LOW: low-speed • HIGH: full-speed. <p>push-pull input</p>
V _{REG(3V3)}	7	P	-	<p>output of the internal voltage regulator; an external decoupling capacitor of 0.1 μF is required</p>
SUSPEND	8	I	-	<p>suspend selection input for ATX; effective when bit SPD_SUSP_CTRL = 0:</p> <ul style="list-style-type: none"> • LOW: normal operating • HIGH: suspend. <p>push-pull input</p>
OE_N/ INT_N	9	I/O	high-Z	<p>OE_N input — enable driving DP and DM when in the USB mode</p> <p>INT_N output — interrupt (push pull) when suspended and bit OE_INT_EN = 1</p> <p>bidirectional; push-pull input; three-state output</p>
VM	10	O	-	<p>single-ended DM receiver output</p> <p>push-pull output</p>
VP	11	O	-	<p>single-ended DP receiver output</p> <p>push-pull output</p>
RCV	12	O	0	<p>differential receiver output; reflects the differential value of DP and DM</p> <p>push-pull output</p>

Table 2: Pin description^[1]...continued

Symbol ^[2]	Pin	Type ^[3]	Reset value	Description
SE0/VM	13	I/O	- ^[4]	SE0 (input and output) — SE0 function in DAT_SE0 USB mode VM (input and output) — VM function in VP_VM USB mode bidirectional; push-pull input; three-state output
DAT/VP	14	I/O	- ^[4]	DAT (input and output) — DAT function in DAT_SE0 USB mode VP (input and output) — VP function in VP_VM USB mode bidirectional; push-pull input; three-state output
DM	15	A/O	-	USB data minus pin (D-)
DP	16	A/O	-	USB data plus pin (D+)
AGND	17	P	-	analog ground
ID	18	A/O	-	identification detector input and output; connected to the ID pin of the USB mini receptacle
V _{BUS}	19	A/O	-	V _{BUS} line input and output of the USB interface; place an external decoupling capacitor of 0.1 μF close to this pin
V _{BAT}	20	P	-	supply voltage (2.7 V to 4.5 V)
C1	21	A/O	-	charge pump capacitor pin 1; typically use a 100 nF capacitor between pins C1 and C2
C2	22	A/O	-	charge pump capacitor pin 2; typically use a 100 nF capacitor between pins C1 and C2
CGND	23	P	-	ground for the charge pump
V _{DD_LGC}	24	P	-	supply voltage for the interface logic signals (1.65 V to 3.6 V)
DGND	exposed die pad	P	-	digital ground

[1] A detailed description of these pins can be found in [Section 8.9](#).
 [2] Symbol names ending with underscore N (for example, NAME_N) indicate active LOW signals.
 [3] I = input; O = output; I/O = digital input/output; OD = open-drain output; A/O = analog input/output; P = power or ground pin.
 [4] High-Z when pin OE_N/INT_N is LOW. Driven LOW when pin OE_N/INT_N is HIGH.

8. Functional description

8.1 Serial controller

The serial controller includes the following functions:

- I²C-bus slave interface
- Interrupt generator
- Mode Control registers
- OTG registers
- Interrupt related registers
- Device identification registers.

The serial controller acts as an I²C-bus slave, and uses the SCL and SDA pins to communicate with the OTG controller.

For more details on serial controller, see [Section 11](#).

8.2 V_{BUS} charge pump

The charge pump supplies current to the V_{BUS} line. It can operate in any of the following modes:

- Output 5 V at current greater than 8 mA
- Pull-up V_{BUS} to 3.3 V through a resistor (R_{VBUS(PU)}) for initiating V_{BUS} pulsing SRP
- Pull-down V_{BUS} to ground through a resistor (R_{VBUS(PD)}) for discharging V_{BUS} before initiating SRP.

8.3 V_{BUS} comparators

V_{BUS} comparators provide indications regarding the voltage level on V_{BUS}.

8.3.1 V_{BUS} valid comparator

This comparator is used by an A-device to determine whether or not the voltage on V_{BUS} is at a valid level for operation. The minimum threshold for the V_{BUS} valid comparator is 4.4 V. Any voltage on V_{BUS} below this threshold is considered to be a fault. During power up, it is expected that the comparator output will be ignored.

8.3.2 Session valid comparator

The session valid comparator is a TTL-level input that determines when V_{BUS} is high enough for a session to start. Both the A-device and the B-device use this comparator to detect when a session is being started. The A-device also uses this comparator to indicate when a session is completed. The session valid threshold of the ISP1301 is between 0.8 V and 2.0 V.

8.3.3 Session end comparator

The session end comparator determines when V_{BUS} is below the B-device session end threshold of 0.2 V to 0.8 V.

8.4 ID detector

In either the active or suspended power mode, the ID detector senses the condition of the ID line and differentiates between the following three conditions:

- Pin ID is floating; bit ID_FLOAT = 1
- Pin ID is shorted to ground; bit ID_GND = 1
- Pin ID is connected to ground through resistor R_{ACC_ID}; bit ID_FLOAT = 0 and bit ID_GND = 0.

The ID detector also has a switch that can be used to ground pin ID. This switch is controlled by bit ID_PULLDOWN in the serial controller.

8.5 Pull-up and pull-down resistors

The pull-up and pull-down resistors include the following switchable resistors:

- Pin DP pull-up
- Pin DP pull-down
- Pin DM pull-up
- Pin DM pull-down.

The pull-up resistor is a context variable as described in the *ECN_27%_Resistor* document. The variable pull-up resistor hardware is implemented to meet the USB ECN_27% specification.

8.6 USB transceiver (ATX)

The behavior of the USB transceiver depends on the operation mode of the ISP1301:

- In the USB mode, the USB transceiver block performs USB full-speed or low-speed transceiver functions. This includes differential driver, differential receiver and single-ended receivers.
- In the transparent general purpose buffer mode or the UART mode, the USB transceiver block functions as a level shifter between the pins DAT/VP and SE0/VM and the pins DP and DM.

8.7 3.3 V DC-DC regulator

The built-in 3.3 V DC-DC regulator conditions the supply voltage (V_{BAT}) for use in the ISP1301:

- $V_{BAT} = 3.6\text{ V to }4.5\text{ V}$: the regulator will output $3.3\text{ V} \pm 10\%$
- $V_{BAT} < 3.6\text{ V}$: the regulator will be bypassed.

The output of the regulator can be monitored on the $V_{REG(3V3)}$ pin.

8.8 Car kit interrupt detector

The car kit interrupt detector is a comparator that detects when the DP line is below the car kit interrupt threshold $V_{PH_CR_INT}$ (0.4 V to 0.6 V). The car kit interrupt detector is enabled in the audio mode only (bit AUDIO_EN = 1).

8.9 Detailed description of pins

8.9.1 ADR/PSW

The ADR/PSW pin has two functions. On reset (including power-on reset), the level on this pin is latched as ADR_REG, which represents the least significant bit (LSB) of the I²C address of the ISP1301. If bit ADR_REG = 0, the I²C-bus address for the ISP1301 is 0101100 (0x2C); if bit ADR_REG = 1, the I²C-bus address for the ISP1301 is 0101101 (0x2D).

After reset, the ADR/PSW pin can be programmed as an output. If in the Mode Control 2 register bit PSW_OE = 1, then the ADR/PSW output will be enabled. The logic level will be determined by bit ADR_REG. If bit ADR_REG = 0, then the ADR/PSW pin will drive HIGH. If bit ADR_REG = 1, then the ADR/PSW pin will drive LOW.

The ADR/PSW pin can be used to turn on or off the external charge pump. The ISP1301 built-in charge pump supports V_{BUS} current at 8 mA. If the application needs more current support (for example, 50 mA), an external charge pump may be needed. In this case, the ADR/PSW pin can act as a power switch for the external charge pump. Figure 4 shows an example of using external charge pump.

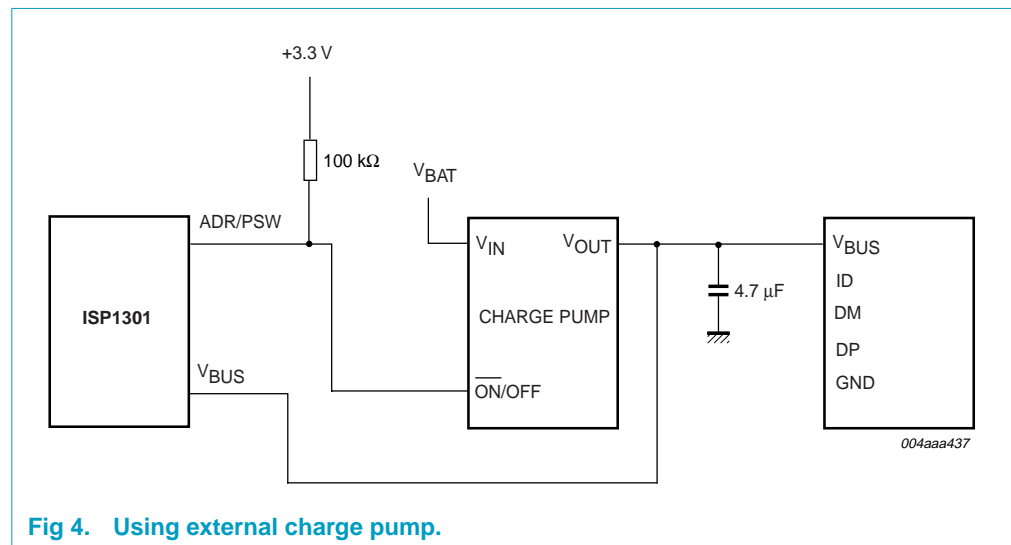

Fig 4. Using external charge pump.

8.9.2 SCL and SDA

The SCL (serial clock) and SDA (serial data) signals implement a two-wire serial I²C-bus.

8.9.3 RESET_N

Active LOW asynchronous reset for all digital logic. Either connect this pin to V_{DD_LGC} for power-on reset or apply a minimum of 10 μ s LOW pulse for hardware reset.

8.9.4 INT_N

The INT_N (interrupt) pin is asserted while an interrupt condition exists. It is deasserted when the Interrupt Latch register is cleared. The INT_N pin is open-drain, and, therefore, can be connected using a wired-AND with other interrupt signals.

8.9.5 OE_N/INT_N

Pin OE_N/INT_N is normally an input to the ISP1301.

When bit TRANSP_EN = 0 and bit UART_EN = 0, the OE_N/INT_N pin controls the direction of DAT/VP, SE0/VM, DP and DM as indicated in Table 4.

When suspended (either pin SUSPEND = HIGH or bit SUSPEND_REG = 1) and bit OE_INT_EN = 1, pin OE_N/INT_N becomes a push-pull output (active LOW) to indicate the interrupt condition.

8.9.6 SE0/VM, DAT/VP, RCV, VM and VP

The ISP1301 transmits USB data on the USB line under the following conditions:

- Bit TRANSP_EN = 0
- Bit UART_EN = 0
- Pin OE_N/INT_N = LOW.

Table 10 shows the operation of the SE0/VM and DAT/VP pins during the transmit operation. The RCV pin is not used during transmit.

The ISP1301 receives USB data from the USB line under the following conditions:

- Bit TRANSP_EN = 0
- Bit UART_EN = 0
- Pin OE_N/INT_N = HIGH.

Table 12 shows the operation of the SE0/VM, DAT/VP and RCV pins during the receive operation.

The VP and VM pins are single-ended receiver outputs of the DP and DM pins, respectively.

8.9.7 DP and DM

The DP (data plus) and DM (data minus) pins implement the USB data signals. When in the transparent general-purpose buffer mode, the ISP1301 operates as a level shifter between the (DAT/VP, SE0/VM) and (DP, DM) pins.

8.9.8 ID

The ID (identification) pin is connected to the ID pin on the USB mini receptacle. An internal pull-up resistor (to $V_{REG(3V3)}$) is connected to this pin. When bit ID_PULLDOWN is set, the ID pin will be shorted to ground.

8.9.9 V_{BUS}

This pin acts as an input to the V_{BUS} comparator or an output from the charge pump.

When the VBUS_DRV bit of the OTG Control register is asserted, the ISP1301 tries to drive V_{BUS} to a voltage of 4.4 V to 5.25 V with an output current capability of at least 8 mA.

8.9.10 V_{BAT}

This pin is an input and supplies power to the ISP1301. The ISP1301 operates when V_{BAT} is between 2.7 V and 4.5 V.

8.9.11 C1 and C2

The C1 and C2 pins are for connecting the flying capacitor of the charge pump. The output current capacity of the charge pump depends on the value of the capacitor. For maximum efficiency, place capacitors as close as possible to the pins.

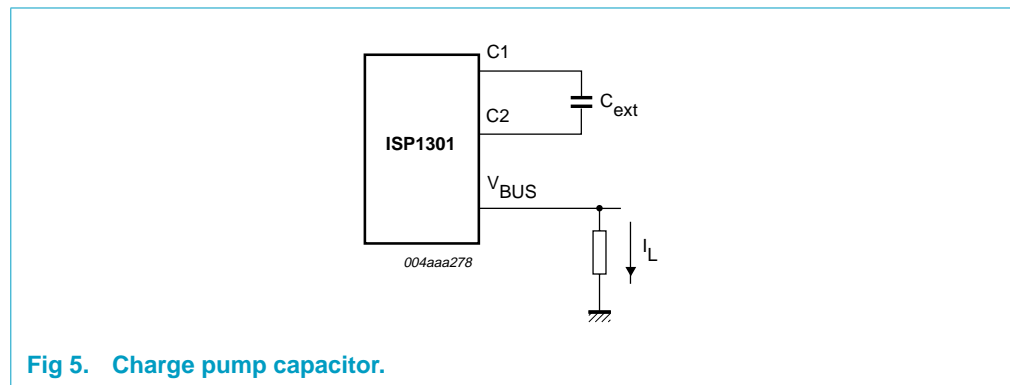

Fig 5. Charge pump capacitor.

Table 3: Recommended charge pump capacitor value

C _{ext}	I _L (max) ^[1]
47 nF	8 mA
100 nF	18 mA ^[2]

[1] For output voltage V_{BUS} > 4.7 V (bit VBUS_VLD = 1).

[2] For V_{BAT} = 3.0 V to 4.5 V.

8.9.12 V_{DD_LGC}

This pin is an input and sets logic thresholds. It also powers the pads of the following logic pins:

- ADR/PSW
- DAT/VP, SE0/VM and RCV
- VM and VP
- INT_N
- OE_N/INT_N
- RESET_N
- SPEED
- SUSPEND
- SCL and SDA.

8.9.13 AGND, CGND and DGND

AGND, CGND and DGND are ground pins for analog, charge pump and digital circuits, respectively. These pins can be connected separately or together depending on the system performance requirements.

9. Modes of operation

There are four types of modes in the ISP1301:

- Power modes
- Direct I²C-bus mode
- USB modes
- Transparent modes.

9.1 Power modes

The power modes of the ISP1301 are as follows:

- Active power mode: power is on.
- USB suspend mode: to reduce power consumption, the USB differential receiver is powered down.
- Global power-down mode: set bit GLOBAL_PWR_DN = 1 of the Mode Control 2 register; the differential transmitter and receiver, clock generator, charge pump, and all biasing circuits are turned off to reduce power consumption to the minimum possible; for details on waking up the clock, see [Section 12](#).

9.2 Direct I²C-bus mode

In the direct I²C-bus mode, an external I²C-bus master (OTG controller) directly communicates with the serial controller through the SCL and SDA lines. The serial controller has a built-in I²C-bus slave function.

In this mode, an external I²C-bus master can access the internal registers of the device (Status, Control, Interrupt, and so on) through the I²C-bus interface.

The supported I²C-bus bit rate is 100 kbit/s (maximum).

The ISP1301 is in the direct I²C-bus mode when either bit TRANSP_EN bit = 0 or pin OE_N/INT_N is deasserted.

9.3 USB modes

The four USB modes of the ISP1301 are:

- VP_VM unidirectional mode
- VP_VM bidirectional mode
- DAT_SE0 unidirectional mode
- DAT_SE0 bidirectional mode.

In the VP_VM USB mode, the DAT/VP pin is used for the VP function, the SE0/VM pin is used for the VM function, and the RCV pin is used for the RCV function.

In the DAT_SE0 USB mode, the DAT/VP pin is used for the DAT function, the SE0/VM pin is used for the SE0 function, and the RCV pin is not used.

In the unidirectional mode, the DAT/VP and SE0/VM pins are always inputs. In the bidirectional mode, the direction of these signals depends on the OE_N/INT_N input.

Table 6 specifies the functionality of the device during the four USB modes.

The ISP1301 is in the USB mode when both the TRANSP_EN and UART_EN bits are cleared.

9.4 Transparent modes

9.4.1 Transparent general-purpose buffer mode

In the transparent general-purpose buffer mode, the DAT/VP and SE0/VM pins are connected to the DP and DM pins, respectively. Using bits TRANSP_BDIR1 and TRANSP_BDIR0 of the Mode Control 2 register as specified in Table 8, you can control the direction of data transfer. The ISP1301 is in the transparent general-purpose buffer mode if bit TRANSP_EN = 1 and bit DAT_SE0 = 1.

9.4.2 Transparent UART mode

When in the transparent UART mode, the ATX behaves as two logic level translator between the following pins:

- For TxD signal: from SE0/VM (V_{DD_LGC} level) to DM (+3.3 V level)
- For RxD signal: from DP (+3.3 V level) to DAT/VP (V_{DD_LGC} level).

In the UART mode, the OTG controller is allowed to connect a UART to the DAT/VP and SE0/VM pins of the ISP1301.

The UART mode is entered by setting the UART_EN bit in the Mode Control 1 register. The UART mode is equivalent to one of the transparent general purpose buffer mode (bit TRANSP_BDIR1 = 1, bit TRANSP_BDIR0 = 0).

9.4.3 Summary tables

Table 4: Device operating modes

Mode	USB suspend condition ^[1]	Bit DAT_SE0	Pin OE_N/INT_N	Bit TRANSP_EN	Bit UART_EN	Description
Direct I²C-bus mode						
Direct I ² C-bus mode	X	X	X	0	X	
	X	X	HIGH	1	X	
	X	1	X	1	X	
USB modes						
USB suspend mode	1	X	X	0	0	see Table 5 and Table 7
USB functional mode	0	X	X	0	0	ATX is fully functional; see Table 6
Transparent modes						
Transparent general-purpose buffer mode	X	1	X	1	0	ATX is not functional; see Table 8
Transparent UART mode	X	X	X	X	1	DAT/VP <= DP (RxD signal of UART) SE0/VM => DM (TxD signal of UART); ATX is not functional

[1] Conditions:

- bit SPD_SUSP_CTRL = 0 and pin SUSPEND = HIGH, or
- bit SPD_SUSP_CTRL = 1 and bit SUSPEND_REG = 0.

Table 5: USB suspend mode: I/O

Pin	Function
DP as output	can be driven if pin OE_N/INT_N is active LOW, otherwise high-Z ^[1]
DM as output	can be driven if pin OE_N/INT_N is active LOW, otherwise high-Z ^[1]
V _{BUS}	can be driven depending on bit VBUS_DRV
SCL	connected to SCL I/O of the I ² C-bus slave
SDA	connected to SDA I/O of the I ² C-bus slave

[1] In the USB suspend mode, the ISP1301 can drive the DP and DM lines, if the OE_N/INT_N input (when the OE_INT_EN bit is not set) is LOW. In such a case, these outputs are driven as in the USB functional modes, but with the full-speed characteristics, irrespective of the value of the SPEED input pin or the SPEED_REG bit.

Table 6: USB functional modes: I/O values^[1]

USB mode		Bit		Pin					
		DAT_SE0	BI_DI	OE_N/INT_N	DAT/VP	SE0/VM	VP	VM	RCV
VP_VM	unidirectional	0	0	X	TxD+ ^[2]	TxD- ^[2]	RxD+ ^[3]	RxD- ^[3]	RxD ^[3]
	bidirectional	0	1	LOW	TxD+ ^[2]	TxD- ^[2]			
		0	1	HIGH	RxD+ ^[3]	RxD- ^[3]			
DAT_SE0	unidirectional	1	0	X	TxD ^[4]	FSE0 ^[5]			
	bidirectional	1	1	LOW	TxD ^[4]	FSE0 ^[5]			
		1	1	HIGH	RxD ^[6]	RSE0 ^[7]			

[1] Some of the modes and signals are provided to achieve backward compatibility with IP cores.

[2] TxD+ and TxD- are single-ended inputs for driving the DP and DM outputs, respectively, in the single-ended mode.

[3] RxD+ and RxD- are the outputs of the single-ended receivers connected to DP and DM, respectively.

[4] TxD is the input for driving DP and DM in the DAT_SE0 mode.

[5] FSE0 is for forcing an SE0 on the DP and DM lines in the DAT_SE0 mode.

[6] RxD is the output of the differential receiver.

[7] RSE0 is an output indicating that an SE0 has been received on the DP and DM lines.

Table 7: USB suspend mode: I/O values

USB suspend mode	Input pin		Output pin				
	DP	DM	DAT/VP	SE0/VM	VP	VM	RCV
DAT_SE0 (bit DAT_SE0 = 1)	LOW	LOW	LOW	HIGH	LOW	LOW	LOW
	HIGH	LOW	HIGH	LOW	HIGH	LOW	LOW
	LOW	HIGH	LOW	LOW	LOW	HIGH	LOW
	HIGH	HIGH	HIGH	LOW	HIGH	HIGH	LOW
VP_VM (bit DAT_SE0 = 0)	LOW	LOW	LOW	LOW	LOW	LOW	LOW
	HIGH	LOW	HIGH	LOW	HIGH	LOW	LOW
	LOW	HIGH	LOW	HIGH	LOW	HIGH	LOW
	HIGH	HIGH	HIGH	HIGH	HIGH	HIGH	LOW

Table 8: Transparent general-purpose buffer mode

Bit TRANSP_BDIR[1:0]	Direction of the data flow	
00	DAT/VP => DP	SE0/VM => DM
01	DAT/VP => DP	SE0/VM <= DM
10	DAT/VP <= DP	SE0/VM => DM
11	DAT/VP <= DP	SE0/VM <= DM

10. USB transceiver

10.1 Differential driver

The operation of the driver is described in [Table 9](#). The register bits and the pins used in the column heading are described in [Section 11.1](#) and [Section 8.9](#), respectively.

Table 9: Transceiver driver operation setting

Suspend ^[1]	Bit TRANSP_EN	Pin OE_N/ INT_N	Bit DAT_SE0	Differential driver
0	0	LOW	0	output value from DAT/VP to DP and SE0/VM to DM
0	0	LOW	1	output value from DAT/VP to DP and DM if SE0/VM is 0; otherwise, drive both DP and DM LOW
1	0	LOW	X	output value from DAT/VP to DP and DM
X	X	HIGH	X	high-Z
X	1	X	X	high-Z

[1] Can be controlled by using either the SUSPEND pin or the SUSPEND_REG bit.

Table 10: USB functional mode: transmit operation

USB mode	Input pin		Output pin	
	DAT/VP	SE0/VM	DP	DM
DAT_SE0	LOW	LOW	LOW	HIGH
	HIGH	LOW	HIGH	LOW
	LOW	HIGH	LOW	LOW
	HIGH	HIGH	LOW	LOW
VP_VM	LOW	LOW	LOW	LOW
	HIGH	LOW	HIGH	LOW
	LOW	HIGH	LOW	HIGH
	HIGH	HIGH	HIGH	HIGH

10.2 Differential receiver

[Table 11](#) describes the operation of the differential receiver. The register bits and the pins used in the column heading are described in [Section 11.1](#) and [Section 8.9](#), respectively.

The detailed behavior of the receive transceiver operation is given in [Table 12](#).

Table 11: Differential receiver operation settings

Suspend ^[1]	Bit TRANSP_EN	Pin OE_N/INT_N	Bit DAT_SE0	Differential receiver
1	X	X	X	0
X	X	LOW	X	0
X	1	X	X	0
0	0	HIGH	1	output differential value from DP and DM to DAT/VP and RCV
0	0	HIGH	0	output differential value from DP and DM to RCV

[1] Can be controlled by using either the SUSPEND pin or the SUSPEND_REG bit.

Table 12: USB functional mode: receive operation

USB mode	Suspend ^[1]	Input pin		Output pin		
		DP	DM	DAT/VP	SE0/VM	RCV
DAT_SE0	0	LOW	LOW	RCV	HIGH	last value of RCV
DAT_SE0	0	HIGH	LOW	HIGH	LOW	HIGH
DAT_SE0	0	LOW	HIGH	LOW	LOW	LOW
DAT_SE0	0	HIGH	HIGH	RCV	LOW	last value of RCV
DAT_SE0	1	LOW	LOW	LOW	HIGH	LOW
DAT_SE0	1	HIGH	LOW	HIGH	LOW	LOW
DAT_SE0	1	LOW	HIGH	LOW	LOW	LOW
DAT_SE0	1	HIGH	HIGH	HIGH	LOW	LOW
VP_VM	0	LOW	LOW	LOW	LOW	last value of RCV
VP_VM	0	HIGH	LOW	HIGH	LOW	HIGH
VP_VM	0	LOW	HIGH	LOW	HIGH	LOW
VP_VM	0	HIGH	HIGH	HIGH	HIGH	last value of RCV
VP_VM	1	LOW	LOW	LOW	LOW	LOW
VP_VM	1	HIGH	LOW	HIGH	LOW	LOW
VP_VM	1	LOW	HIGH	LOW	HIGH	LOW
VP_VM	1	HIGH	HIGH	HIGH	HIGH	LOW

[1] Can be controlled by using either the SUSPEND pin or the SUSPEND_REG bit.

11. Serial controller

11.1 Register map

Table 13 provides an overview of the serial controller registers.

Table 13: Serial controller registers

Register	Width (bits)	Access ^[1]	Memory address	Functionality	Reference
Vendor ID	16	R	00–01H	device identification registers	Section 11.1.1 on page 17
Product ID	16	R	02–03H		
Version ID	16	R	14–15H		
Mode Control 1	8	R/S/C	Set — 04H Clear — 05H	mode control registers	Section 11.1.2 on page 18
Mode Control 2	8	R/S/C	Set — 12H Clear — 13H		
OTG Control	8	R/S/C	Set — 06H Clear — 07H	OTG registers	Section 11.1.3 on page 19
OTG Status	8	R	10H		
Interrupt Source	8	R	08H	interrupt related registers	Section 11.1.4 on page 20
Interrupt Latch	8	R/S/C	Set — 0AH Clear — 0BH		
Interrupt Enable Low	8	R/S/C	Set — 0CH Clear — 0DH		
Interrupt Enable High	8	R/S/C	Set — 0EH Clear — 0FH		

[1] The R/S/C access type represents a field that can be read, set or cleared (set to 0). A register can be read from either of the indicated addresses—set or clear. Writing logic 1 to the set address causes the associated bit to be set. Writing logic 1 to the clear address causes the associated bit to be cleared. Writing logic 0 to an address has no effect.

11.1.1 Device identification registers

Vendor ID register (Read: 00H–01H): Table 14 provides the bit allocation of the Vendor ID register.

Table 14: Vendor ID register: bit description

Bit	Symbol	Access	Value	Description
15 to 0	VENDORID [15:0]	R	04CCH	Philips Semiconductors' Vendor ID

Product ID register (Read: 02H–03H): The bit allocation of this register is given in Table 15.

Table 15: Product ID register: bit description

Bit	Symbol	Access	Value	Description
15 to 0	PRODUCTID [15:0]	R	1301H	Product ID of the ISP1301

Version ID register (Read: 14H–15H): Table 16 shows the bit allocation of this register.

Table 16: Version ID register: bit description

Bit	Symbol	Access	Value	Description
15 to 0	VERSIONID [15:0]	R	0210H	Version number of the ISP1301

11.1.2 Mode control registers

Mode Control 1 register (Set/Clear: 04H/05H): The bit allocation of the Mode Control 1 register is given in Table 17.

Table 17: Mode Control 1 register: bit allocation

Bit	7	6	5	4	3	2	1	0
Symbol	-	UART_EN	OE_INT_EN	BDIS_ACON_EN	TRANSP_EN	DAT_SE0	SUSPEND_REG	SPEED_REG
Reset	-	0	0	0	0	0	0	0
Access	R/S/C	R/S/C	R/S/C	R/S/C	R/S/C	R/S/C	R/S/C	R/S/C

Table 18: Mode Control 1 register: bit description

Bit	Symbol	Description
7	-	reserved
6	UART_EN	When set, the ATX is in the transparent UART mode.
5	OE_INT_EN	When set and when in the suspend mode, pin OE_N/INT_N becomes an output and is asserted when an interrupt occurs.
4	BDIS_ACON_EN	Enables the A-device to connect if the B-device disconnect is detected; see Section 11.3
3	TRANSP_EN	When set, the ATX is in the transparent mode.
2	DAT_SE0	0 — VP_VM mode 1 — DAT_SE0 mode; see Table 6 and Table 7
1	SUSPEND_REG	Sets the ISP1301 in the suspend mode, if bit SPD_SUSP_CTRL = 1. 0 — active-power mode 1 — USB suspend mode
0	SPEED_REG	Sets the rise time and the fall time of the transmit driver in USB modes, if bit SPD_SUSP_CTRL = 1. 0 — USB low-speed mode 1 — USB full-speed mode

Mode Control 2 register (Set/Clear: 12H/13H): For the bit allocation of this register, see Table 19.

Table 19: Mode Control 2 register: bit allocation

Bit	7	6	5	4	3	2	1	0
Symbol	EN2V7	PSW_OE	AUDIO_EN	TRANSP_BDIR1	TRANSP_BDIR0	BI_DI	SPD_SUSP_CTRL	GLOBAL_PWR_DN
Reset	0	0	0	0	0	1	0	0
Access	R/S/C	R/S/C	R/S/C	R/S/C	R/S/C	R/S/C	R/S/C	R/S/C

Table 20: Mode Control 2 register: bit description

Bit	Symbol	Description
7	EN2V7	0 — $V_{BAT} = 3.0\text{ V}$ to 4.5 V 1 — $V_{BAT} = 2.7\text{ V}$ to 4.5 V
6	PSW_OE	0 — ADR/PSW pin acts as an input 1 — ADR/PSW pin is driven
5	AUDIO_EN	0 — SE receiver is enabled; cr_int detector is disabled 1 — SE receiver is turned off (pin VP = LOW, pin VM = LOW); cr_int detector is enabled
4 to 3	TRANSP_BDIR[1:0]	controls the direction of data transfer in the transparent general-purpose buffer mode; see Table 8
2	BI_DI	0 — direction of DAT/VP and SE0/VM are fixed (transmit only) 1 — direction of DAT/VP and SE0/VM are controlled by pin OE_N/INT_N; see Table 6
1	SPD_SUSP_CTRL	control of speed and suspend in USB modes: 0 — controlled by pins SPEED and SUSPEND 1 — controlled by bit SPEED_REG and bit SUSPEND_REG of the Mode Control 1 register
0	GLOBAL_PWR_DN	0 — normal operation 1 — sets the ISP1301 to the power down mode Activities on the I ² C-bus or any OTG event can wake up the chip; see Section 12

11.1.3 OTG registers

OTG Control register (Set/Clear: 06H/07H): [Table 21](#) provides the bit allocation of the OTG Control register.

Table 21: OTG Control register: bit allocation

Bit	7	6	5	4	3	2	1	0
Symbol	VBUS_CHRG	VBUS_DISCHRG	VBUS_DRV	ID_PULL_DOWN	DM_PULL_DOWN	DP_PULL_DOWN	DM_PULL_UP	DP_PULL_UP
Reset	0	0	0	0	1	1	0	0
Access	R/S/C	R/S/C	R/S/C	R/S/C	R/S/C	R/S/C	R/S/C	R/S/C

Table 22: OTG Control register: bit description

Bit	Symbol	Description
7	VBUS_CHRG	charge V_{BUS} through a resistor to 3.3 V
6	VBUS_DISCHRG	discharge V_{BUS} through a resistor to ground
5	VBUS_DRV	drive V_{BUS} to 5 V through the charge pump
4	ID_PULLDOWN	connect the ID pin to ground
3	DM_PULLDOWN	connect DM pull-down resistor to ground
2	DP_PULLDOWN	connect DP pull-down resistor to ground
1	DM_PULLUP	connect DM pull-up resistor to 3.3 V
0	DP_PULLUP	connect DP pull-up resistor to 3.3 V

OTG Status register (Read: 10H): Table 23 shows the bit allocation of the OTG Status register.

Table 23: OTG Status register: bit allocation

Bit	7	6	5	4	3	2	1	0
Symbol	B_SESS_VLD	B_SESS_END	reserved					
Reset	0	0	0	0	0	0	0	0
Access	R	R	R	R	R	R	R	R

Table 24: OTG Status register: bit description

Bit	Symbol	Description
7	B_SESS_VLD	set when the V_{BUS} voltage is above the B-device session valid threshold (2.0 V to 4.0 V)
6	B_SESS_END	set when the V_{BUS} voltage is below the B-device session end threshold (0.2 V to 0.8 V)
5 to 0	-	reserved

11.1.4 Interrupt related registers

Interrupt Source register (Read: 08H): This register indicates the current state of the signals that can generate an interrupt. The bit allocation of the Interrupt Source register is given in Table 25.

Table 25: Interrupt Source register: bit allocation

Bit	7	6	5	4	3	2	1	0
Symbol	CR_INT	BDIS_ACON	ID_FLOAT	DM_HI	ID_GND	DP_HI	SESS_VLD	VBUS_VLD
Reset	0	0	0	0	0	0	0	0
Access	R	R	R	R	R	R	R	R

Table 26: Interrupt Source register: bit description

Bit	Symbol	Description
7	CR_INT	DP pin is above the car kit interrupt threshold (0.4 V to 0.6 V)
6	BDIS_ACON	set when bit BDIS_ACON_EN is set, and the ISP1301 asserts bit DP_PULLUP after detecting the B-device disconnect
5	ID_FLOAT	ID pin is floating
4	DM_HI	DM pin is HIGH
3	ID_GND	ID pin is connected to ground
2	DP_HI	DP pin is HIGH
1	SESS_VLD	session valid comparator; threshold = 0.8 V to 2.0 V
0	VBUS_VLD	A-device V _{BUS} valid comparator; threshold > 4.4 V

Interrupt Latch register (Set/Clear: 0AH/0BH): This register indicates the source that generated the interrupt. The bit allocation of the Interrupt Latch register is given in [Table 27](#).

Table 27: Interrupt Latch register: bit allocation

Bit	7	6	5	4	3	2	1	0
Symbol	CR_INT	BDIS_ACON	ID_FLOAT	DM_HI	ID_GND	DP_HI	SESS_VLD	VBUS_VLD
Reset	0	0	0	0	0	0	0	0
Access	R/S/C	R/S/C	R/S/C	R/S/C	R/S/C	R/S/C	R/S/C	R/S/C

Table 28: Interrupt Latch register: bit description

Bit	Symbol	Description
7	CR_INT	interrupt for CR_INT status change
6	BDIS_ACON	interrupt for BDIS_ACON status change
5	ID_FLOAT	interrupt for ID_FLOAT status change
4	DM_HI	interrupt for DM_HI status change
3	ID_GND	interrupt for ID_GND status change
2	DP_HI	interrupt for DP_HI status change
1	SESS_VLD	interrupt for SESS_VLD status change
0	VBUS_VLD	interrupt for VBUS_VLD status change

Interrupt Enable Low register (Set/Clear: 0CH/0DH): This register enables interrupts on transition from true to false. For the bit allocation of this register, see [Table 29](#).

Table 29: Interrupt Enable Low register: bit allocation

Bit	7	6	5	4	3	2	1	0
Symbol	CR_INT	BDIS_ACON	ID_FLOAT	DM_HI	ID_GND	DP_HI	SESS_VLD	VBUS_VLD
Reset	0	0	0	0	0	0	0	0
Access	R/S/C	R/S/C	R/S/C	R/S/C	R/S/C	R/S/C	R/S/C	R/S/C

Table 30: Interrupt Enable Low register: bit description

Bit	Symbol	Description
7	CR_INT	interrupt enable for CR_INT status change from 1 to 0
6	BDIS_ACON	interrupt enable for BDIS_ACON status change from 1 to 0
5	ID_FLOAT	interrupt enable for ID_FLOAT status change from 1 to 0
4	DM_HI	interrupt enable for DM_HI status change from 1 to 0
3	ID_GND	interrupt enable for ID_GND status change from 1 to 0
2	DP_HI	interrupt enable for DP_HI status change from 1 to 0
1	SESS_VLD	interrupt enable for SESS_VLD status change from 1 to 0
0	VBUS_VLD	interrupt enable for VBUS_VLD status change from 1 to 0

Interrupt Enable High register (Set/Clear: 0EH/0FH): The Interrupt Enable High register enables interrupts on transition from FALSE to TRUE. [Table 31](#) provides the bit allocation of this register.

Table 31: Interrupt Enable High register: bit allocation

Bit	7	6	5	4	3	2	1	0
Symbol	CR_INT	BDIS_ACON	ID_FLOAT	DM_HI	ID_GND	DP_HI	SESS_VLD	VBUS_VLD
Reset	0	0	0	0	0	0	0	0
Access	R/S/C	R/S/C	R/S/C	R/S/C	R/S/C	R/S/C	R/S/C	R/S/C

Table 32: Interrupt Enable High register: bit description

Bit	Symbol	Description
7	CR_INT	interrupt enable for CR_INT status change from 0 to 1
6	BDIS_ACON	interrupt enable for BDIS_ACON status change from 0 to 1
5	ID_FLOAT	interrupt enable for ID_FLOAT status change from 0 to 1
4	DM_HI	interrupt enable for DM_HI status change from 0 to 1
3	ID_GND	interrupt enable for ID_GND status change from 0 to 1
2	DP_HI	interrupt enable for DP_HI status change from 0 to 1
1	SESS_VLD	interrupt enable for SESS_VLD status change from 0 to 1
0	VBUS_VLD	interrupt enable for VBUS_VLD status change from 0 to 1

11.2 Interrupts

[Table 26](#) indicates the signals that can generate interrupts. Any of the signals given in [Table 26](#) can generate an interrupt when the signal becomes either LOW or HIGH. After an interrupt has been generated, the OTG controller should be able to read the status of each signal and the bit that indicates whether or not that signal generated the interrupt.

A bit in the Interrupt Latch register is set when any of these occurs:

- Writing logic 1 to its set address causes the corresponding bit to be set
- The corresponding bit in the Interrupt Enable High register is set, and the associated signal changes from LOW to HIGH
- The corresponding bit in the Interrupt Enable Low register is set, and the associated signal changes from HIGH to LOW.

The Interrupt Latch register bit is cleared by writing logic 1 to its clear address.

11.3 Autoconnect

The Host Negotiation Protocol (HNP) in the OTG supplement specifies the following sequence of events to transfer the role of the host from the A-device to the B-device:

1. The A-device puts the bus in the suspend state
2. The B-device simulates a disconnect by deasserting its DP pull-up
3. The A-device detects SE0 on the bus, and asserts its DP pull-up
4. The B-device detects that the DP line is HIGH, and takes the role of the host.

The OTG supplement specifies that the time between the B-device deasserting its DP pull-up and the A-device asserting its pull-up must be less than 3 ms. For an A-device with a slow interrupt response time, 3 ms may not be enough time to write an I²C-bus command to the ISP1301 to assert the DP pull-up. An alternative method is for the A-device transceiver to automatically assert the DP pull-up after detecting an SE0 from the B-device.

The sequence of events is as follows:

After finishing data transfers between the A-device and the B-device and before suspending the bus, the A-device sends SOFs. The B-device receives these SOFs, and does not transmit any packet back to the A-device. During this time, the A-device sets the BDIS_ACON_EN bit in the ISP1301. This enables the ISP1301 to look for SE0 whenever the A-device is not transmitting (that is, whenever the OE_N/INT_N pin of the ISP1301 is not asserted). After the BDIS_ACON_EN bit is set, the A-device stops transmitting SOFs and allows the bus to go to the idle state. If the B-device disconnects, the bus goes to SE0, and the ISP1301 logic automatically turns on the A-device pull-up.

12. Clock wake up scheme

This section explains the ISP1301 clock stop timing, events triggering the clock to wake up, and the timing of the clock wake up.

12.1 Power down event

The clock is stopped when the GLOBAL_PWR_DN bit is set. It takes approximately 8 ms for the clock to stop from the time the power down condition is detected. The clock always stops at its falling edge. The waveform is given in [Figure 6](#).

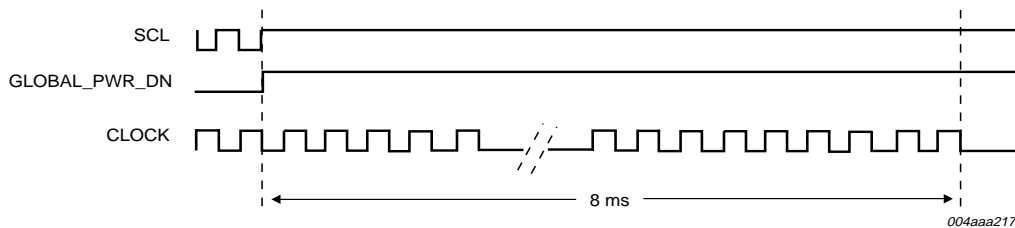

Fig 6. Clock stopped using the GLOBAL_PWR_DN bit.

12.2 Clock wake up events

The clock wakes up when any of the following events occur on the ISP1301 pins:

- SCL goes LOW
- V_{BUS} goes above the session valid threshold (0.8 V to 2.0 V), provided the SESS_VLD bit in the Interrupt Enable High register is set.
- ID changes when mini-A plug is inserted, provided the ID_FLOAT bit in the Interrupt Enable Low register is set.
- ID changes when mini-A plug is removed, provided the ID_FLOAT bit in the Interrupt Enable High register is set.
- DP goes HIGH, provided the DP_HI bit in the Interrupt Enable High register is set.
- DM goes HIGH, provided the DM_HI bit in the Interrupt Enable High register is set.

The event triggers the clock to start and a stable clock is guaranteed after about six clock periods, which is approximately 8 μ s. The startup analog clock time is 10 μ s. Therefore, the total estimated start time after a triggered event is about 20 μ s. The clock will always start at its rising edge.

Waveforms of the clock wake up because of different events are given in [Figure 7](#), [Figure 8](#), [Figure 9](#), [Figure 10](#) and [Figure 11](#).

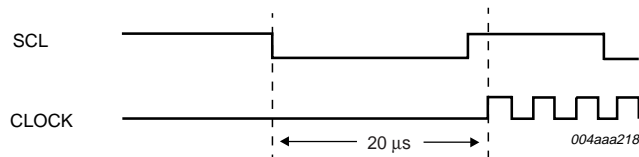

Fig 7. Clock wake up using SCL.

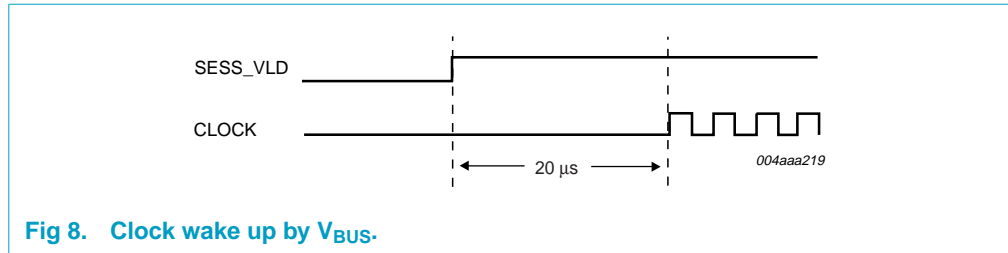

Fig 8. Clock wake up by VBUS.

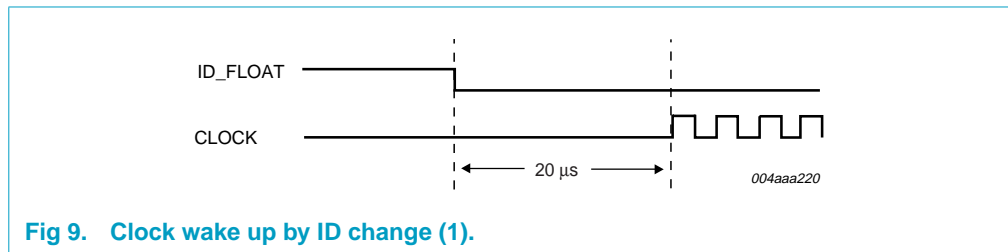

Fig 9. Clock wake up by ID change (1).

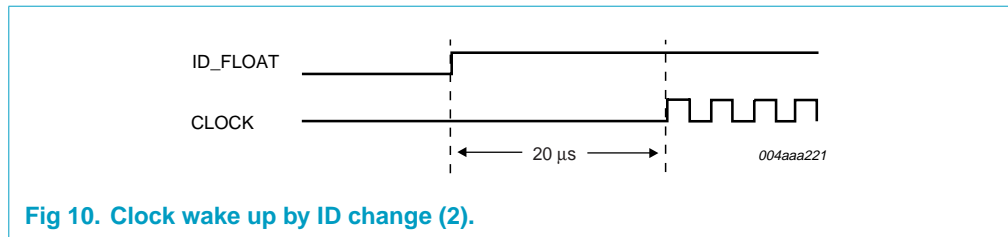

Fig 10. Clock wake up by ID change (2).

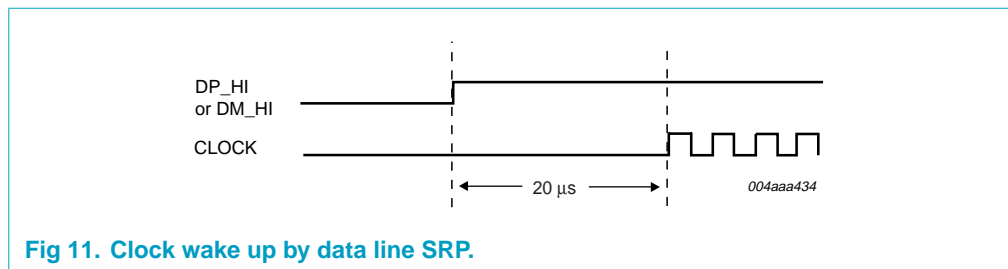

Fig 11. Clock wake up by data line SRP.

When an event is triggered and the clock is started, it will remain active for 8 ms. If the GLOBAL_PWR_DN bit is not cleared within this 8 ms period, the clock will stop. If the clock wakes up because of any event other than SCL going LOW, an interrupt will be generated once the clock is active.

13. I²C-bus protocol

For detailed information, refer to *The I²C-bus specification; version 2.1*.

13.1 I²C-bus byte transfer format

Table 33: I²C-bus byte transfer format^[1]

S	Byte 1	A	Byte 2	A	Byte 3	A	...	A	P
	8 bits		8 bits		8 bits		...		

[1] S = Start; A = Acknowledge; P = Stop.

13.2 I²C-bus device address

Table 34: Device address byte 1

Bit	7	6	5	4	3	2	1	0
	device address							-
Name	A6	A5	A4	A3	A2	A1	A0	R/W
Value	0	1	0	1	1	0	X	X

Table 35: Bit description

Bit	Symbol	Description
7 to 1	A[6:0]	Device address: The device address of the ISP1301 is: 0101 10 (A0). The value of A0 (LSB) is loaded from pin ADR/PSW during reset (including power-on reset). If pin ADR/PSW = HIGH, bit A0 = 1; otherwise bit A0 = 0.
0	R/W	Read/write command. 0 — write 1 — read.

13.3 Write format

A write operation can be performed as:

- One-byte write to the specified register address
- Multi-byte write to N consecutive registers, starting from the specified start address. N defines the number of registers to write. If N = 1, only the start register is written.

13.3.1 One-byte write

Figure 12 illustrates the byte sequence.

Table 36: Transfer format description for one-byte write

Byte	Description
S	master starts with a START condition
Device select	master transmits device address and write command bit R/W = 0
ACK	slave generates an acknowledgment
Register address K	master transmits address of register K

Table 36: Transfer format description for one-byte write...continued

Byte	Description
ACK	slave generates an acknowledgment
Write data K	master writes data to register K
ACK	slave generates an acknowledgment
P	master generates a STOP condition

13.3.2 Multiple-byte write

Figure 12 illustrates the byte sequence.

Table 37: Transfer format description for multiple-byte write

Byte	Description
S	master starts with a START condition
Device select	master transmits device address and write command bit R/W = 0
ACK	slave generates an acknowledgment
Register address K	master transmits address of register K. This is the start address for writing multiple data bytes to consecutive registers. After a byte is written, the register address is automatically incremented by 1. Remark: If the master writes to a non-existent register, the slave must send a 'not ACK' and also must not increment the index address.
ACK	slave generates an acknowledgment
Write data K	master writes data to register K
ACK	slave generates an acknowledgment
Write data K + 1	master writes data to register K + 1
ACK	slave generates an acknowledgment
:	:
Write data K + N - 1	master writes data to register K + N - 1. When the incremented address K + N - 1 becomes > 255, the register address rolls over to 0. Therefore, it is possible that some registers may be overwritten, if the transfer is not stopped before the rollover.
ACK	slave generates an acknowledgment
P	master generates a STOP condition

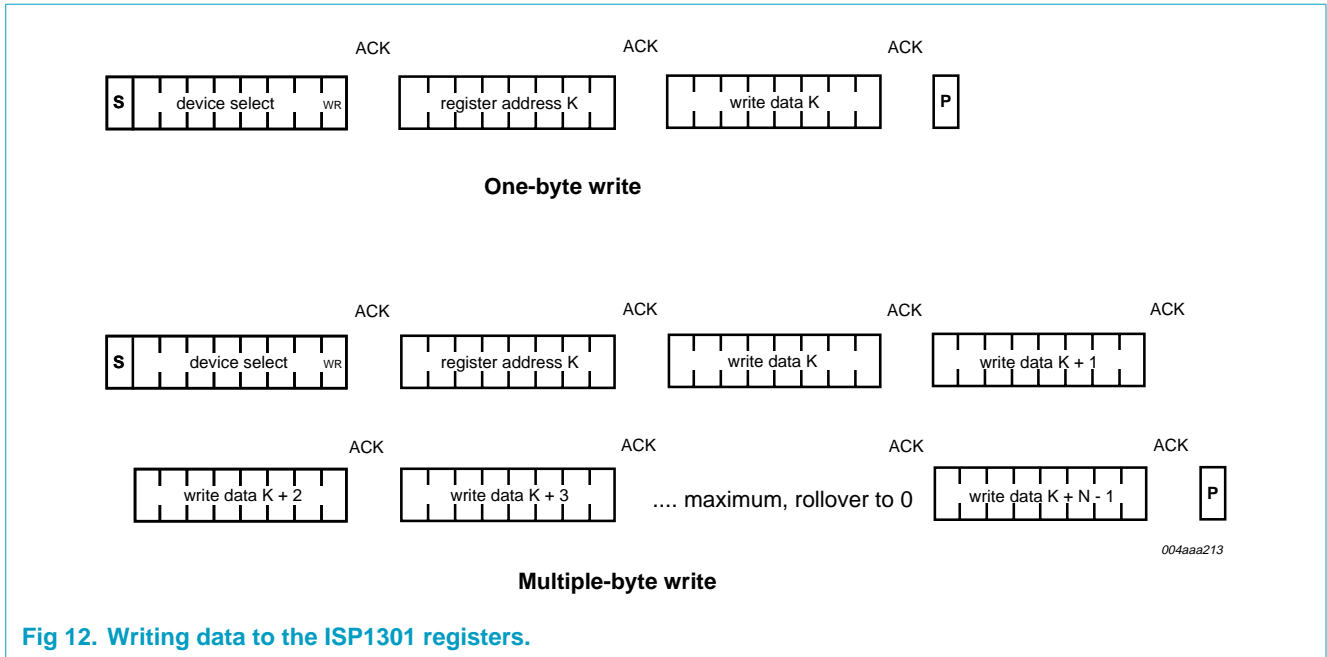

Fig 12. Writing data to the ISP1301 registers.

13.4 Read format

A read operation can be performed in two ways:

- Current address read: to read the register at the current address.
 - Single register read.
- Random address read: to read N registers starting at a specified address. N defines the number of registers to be read. If N = 1, only the start register is read.
 - Single register read
 - Multiple register read.

13.4.1 Current address read

Figure 13 illustrates the byte sequence.

Table 38: Transfer format description for current address read

Byte	Description
S	master starts with a START condition
Device select	master transmits device address and read command bit R/W = 1
ACK	slave generates an acknowledgment
Read data K	slave transmits and master reads data from register K. If the start address is not specified, the read operation starts from where the index register is pointing to because of a previous read or write operation.
No ACK	master terminates the read operation by generating a No Acknowledge
P	master generates a stop condition

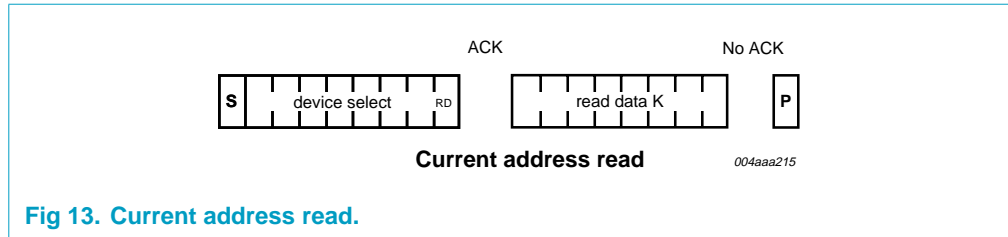

Fig 13. Current address read.

13.4.2 Random address read

Single read: Figure 14 illustrates the byte sequence.

Table 39: Transfer format description for single-byte read

SDA line	Description
S	master starts with a START condition
Device select	master transmits device address and writes command bit R/W = 0
ACK	slave generates an acknowledgment
Register address K	master transmits (start) address of register K to be read from
ACK	slave generates an acknowledgment
Device select	master transmits device address and read command bit R/W = 1
ACK	slave generates an acknowledgment
Read data K	slave transmits and master reads data from register K
No ACK	master terminates the read operation by generating a No Acknowledge
P	master generates a STOP condition

Multiple read: Figure 14 illustrates the byte sequence.

Table 40: Transfer format description for multiple-byte read

SDA line	Description
S	master starts with a START condition
Device select	master transmits device address and write command bit R/W = 0
ACK	slave generates an acknowledgment
Register address K	master transmits (start) address of register K to be read from
ACK	slave generates an acknowledgment
Device select	master transmits device address and read command bit R/W = 1
ACK	slave generates an acknowledgment
Read data K	slave transmits and master reads data from register K. After a byte is read, the address is automatically incremented by 1.
ACK	slave generates an acknowledgment
Read data K + 1	slave transmits and master reads data from register K + 1
ACK	slave generates an acknowledgment
:	:
Read data K + N - 1	slave transmits and master reads data register K + N - 1. This is the last register to read. After incrementing, the address rolls over to 0. Here, N represents the number of addresses available in the slave.
No ACK	master terminates the read operation by generating a No Acknowledge
P	master generates a STOP condition

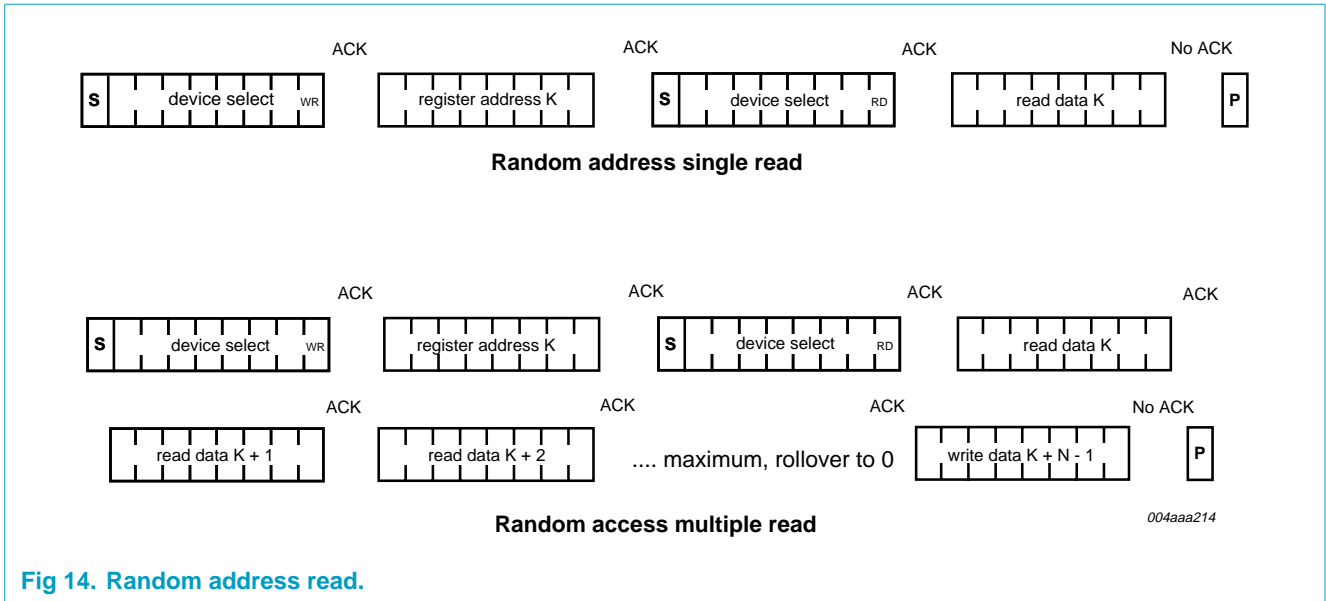

Fig 14. Random address read.

14. Limiting values

Table 41: Absolute maximum ratings

In accordance with the Absolute Maximum Rating System (IEC 60134).

Symbol	Parameter	Conditions	Min	Max	Unit
V_{BAT}	supply voltage		-0.5	+5.5	V
V_{DD_LGC}	I/O supply voltage		-0.5	+4.6	V
V_I	input voltage	$V_I = -1.8\text{ V to }+5.4\text{ V}$	-0.5	$V_{DD_LGC} + 0.5$	V
I_{lu}	latch-up current		-	100	mA
V_{esd}	electrostatic discharge voltage	$I_{LI} < 1\ \mu\text{A}$			
		pins DP, DM, ID, V_{BUS} , AGND, CGND and DGND	[1] -8	+8	kV
		all other pins	-2	+2	kV
T_{stg}	storage temperature		-60	+125	°C

[1] Equivalent to discharging a 100 pF capacitor through a 1.5 k Ω resistor (Human Body Model). A 4.7 μF capacitor is needed from $V_{REG(3V3)}$ and V_{BUS} to ground.

15. Recommended operating conditions

Table 42: Recommended operating conditions

Symbol	Parameter	Conditions	Min	Typ	Max	Unit
V_{BAT}	supply voltage		2.7	-	4.5	V
V_{DD_LGC}	I/O supply voltage		[1] 1.65	-	3.6	V
V_I	input voltage		0	-	V_{DD_LGC}	V
$V_{I(AI/O)}$	input voltage on analog I/O pins DP and DM		0	-	3.6	V
$V_{O(OD)}$	open-drain output pull-up voltage on pins SCL, SDA and INT_N		0	-	3.6	V
T_{amb}	ambient temperature		-40	-	+85	°C

[1] V_{DD_LGC} should be less than or equal to V_{BAT} .

16. Static characteristics

Table 43: Static characteristics: supply pins

$V_{BAT} = 2.7\text{ V to }4.5\text{ V}$; $V_{DD_LGC} = 1.65\text{ V to }3.6\text{ V}$; $T_{amb} = -40\text{ }^{\circ}\text{C to }+85\text{ }^{\circ}\text{C}$; unless otherwise specified.

Symbol	Parameter	Conditions	Min	Typ	Max	Unit
Charge pump disabled						
$V_{REG(3V3)}$	regulated supply voltage output	$V_{BAT} = 3.0\text{ V to }4.5\text{ V}$	[1] 3.0	-	3.6	V
		$V_{BAT} = 2.7\text{ V to }3.0\text{ V}$	2.7	-	3.0	V
I_{BAT}	operating supply current	transmitting and receiving at 12 Mbit/s; $C_L = 50\text{ pF}$ on pins DP and DM	[2] -	4	8	mA
I_{DD_LGC}	operating I/O supply current	transmitting and receiving at 12 Mbit/s	[2] -	1	2	mA
$I_{BAT(idle)}$	supply current during full-speed idle and SE0	idle: $V_{DP} > 2.7\text{ V}$, $V_{DM} < 0.3\text{ V}$; SE0: $V_{DP} < 0.3\text{ V}$, $V_{DM} < 0.3\text{ V}$	[3] -	-	300	μA
$I_{DD_LGC(static)}$	static I/O supply current	idle, SE0 or suspend	-	-	20	μA
$I_{BAT(pd)}$	power down mode supply current	bit GLOBAL_PWR_DN = 1	[3] -	-	20	μA
Charge pump enabled						
$I_{BAT(cp)}$	operating supply current for the charge pump	$I_{LOAD} = 8\text{ mA}$; ATX is idle	-	-	20	mA
		$I_{LOAD} = 0\text{ mA}$; ATX is idle	-	-	300	μA

[1] In the suspend mode, the minimum voltage is 2.7 V.

[2] Maximum value characterized only, not tested in production.

[3] Excluding any load current to the 1.5 k Ω and 15 k Ω pull-up and pull-down resistors (200 μA typical).

Table 44: Static characteristics: digital pins

$V_{BAT} = 2.7\text{ V to }4.5\text{ V}$; $V_{DD_LGC} = 1.65\text{ V to }3.6\text{ V}$; $T_{amb} = -40\text{ }^{\circ}\text{C to }+85\text{ }^{\circ}\text{C}$; unless otherwise specified.

Symbol	Parameter	Conditions	Min	Typ	Max	Unit
Input levels						
V_{IL}	LOW-level input voltage		-	-	$0.3V_{DD_LGC}$	V
V_{IH}	HIGH-level input voltage		$0.6V_{DD_LGC}$	-	-	V
Output levels						
V_{OL}	LOW-level output voltage	$I_{OL} = 2\text{ mA}$	-	-	0.4	V
		$I_{OL} = 100\text{ }\mu\text{A}$	-	-	0.15	V
V_{OH}	HIGH-level output voltage	$I_{OH} = 2\text{ mA}$	[1] $V_{DD_LGC} - 0.4$	-	-	V
		$I_{OH} = 100\text{ }\mu\text{A}$	$V_{DD_LGC} - 0.15$	-	-	V
Leakage current						
I_{LI}	input leakage current		-1	-	+1	μA
Open-drain outputs						
I_{OZ}	OFF-state output current		-5	-	+5	μA
Capacitance						
C_{IN}	input capacitance	pin to GND	-	-	10	pF

[1] Not applicable for open-drain outputs.

Table 45: Static characteristics: analog I/O pins DP and DM $V_{BAT} = 2.7\text{ V to }4.5\text{ V}$; $V_{DD_LGC} = 1.65\text{ V to }3.6\text{ V}$; $T_{amb} = -40\text{ }^{\circ}\text{C to }+85\text{ }^{\circ}\text{C}$; unless otherwise specified.

Symbol	Parameter	Conditions	Min	Typ	Max	Unit
Input levels						
V_{DI}	differential input sensitivity	$ V_{I(DP)} - V_{I(DM)} $	0.2	-	-	V
V_{CM}	differential common mode voltage	includes V_{DI} range	0.8	-	2.5	V
V_{IL}	LOW-level input voltage		-	-	0.8	V
V_{IH}	HIGH-level input voltage		2.0	-	-	V
Output levels						
V_{OL}	LOW-level output voltage	R_L of 1.5 k Ω to +3.6 V	-	-	0.3	V
V_{OH}	HIGH-level output voltage	R_L of 15 k Ω to GND				
		$V_{BAT} = 3.0\text{ V to }4.5\text{ V}$	2.8	-	3.6	V
		$V_{BAT} = 2.7\text{ V to }3.0\text{ V}$	2.6	-	3.0	V
Leakage current						
I_{LZ}	OFF-state leakage current		-1	-	+1	μA
Capacitance						
C_{IN}	transceiver capacitance	pin to GND	-	-	10	pF
Resistance						
R_{PD}	pull-down resistor on pins DP and DM		14.25	-	24.8	k Ω
R_{PU_DP}	pull-up resistor on pin DP	bus idle	900	-	1575	Ω
		bus driven	1425	-	3090	Ω
R_{PU_DM}	pull-up resistor on pin DM	bus idle	900	-	1575	Ω
		bus driven	1425	-	3090	Ω
Z_{DRV}	driver output impedance	steady-state drive	[1] 34	-	44	Ω
Z_{INP}	input impedance		10	-	-	M Ω
Termination						
V_{TERM}	termination voltage for the upstream port pull-up resistor (R_{PU})		3.0	-	3.6	V

[1] Includes external series resistors of 33 $\Omega \pm 1\%$ each on DP and DM.**Table 46: Static characteristics: analog I/O pin ID** $V_{BAT} = 2.7\text{ V to }4.5\text{ V}$; $V_{DD_LGC} = 1.65\text{ V to }3.6\text{ V}$; $T_{amb} = -40\text{ }^{\circ}\text{C to }+85\text{ }^{\circ}\text{C}$; unless otherwise specified.

Symbol	Parameter	Conditions	Min	Typ	Max	Unit
Resistance						
R_{PU_ID}	pull-up resistor on pin ID to $V_{REG(3V3)}$		77	-	130	k Ω
R_{PD_ID}	impedance to GND	bit ID_PULLDOWN = 1	-	-	10	Ω

Table 46: Static characteristics: analog I/O pin ID...continued $V_{BAT} = 2.7\text{ V to }4.5\text{ V}$; $V_{DD_LGC} = 1.65\text{ V to }3.6\text{ V}$; $T_{amb} = -40\text{ }^{\circ}\text{C to }+85\text{ }^{\circ}\text{C}$; unless otherwise specified.

Symbol	Parameter	Conditions	Min	Typ	Max	Unit
R_{A_ID}	A-device ID impedance to GND	bit ID_GND = 1	-	-	1	k Ω
R_{B_ID}	B-device ID impedance to GND	bit ID_FLOAT = 1	800	-	-	k Ω
R_{ACC_ID}	Accessory device ID impedance to GND	bit ID_GND = 0; bit ID_FLOAT = 0	20	-	200	k Ω

Table 47: Static characteristics: charge pump $V_{BAT} = 2.7\text{ V to }4.5\text{ V}$; $V_{DD_LGC} = 1.65\text{ V to }3.6\text{ V}$; $T_{amb} = -40\text{ }^{\circ}\text{C to }+85\text{ }^{\circ}\text{C}$; unless otherwise specified.

Symbol	Parameter	Conditions	Min	Typ	Max	Unit
Current						
I_{LOAD}	maximum load current	$C_{ext} = 100\text{ nF}$; $V_{BUS} = 4.7\text{ V}$	-	-	8.0	mA
Voltage						
V_{BUS}	regulated V_{BUS} output voltage	$I_{LOAD} = 8\text{ mA}$; $C_{ext} = 100\text{ nF}$	4.65	5	5.25	V
$V_{BUS(LEAK)}$	V_{BUS} leakage voltage	charge pump disabled	-	-	0.2	V
$V_{th(VBUSVLD)}$	V_{BUS} valid threshold		4.4	-	4.65	V
$V_{th(SESEND)}$	V_{BUS} session end comparator threshold		0.2	-	0.8	V
$V_{hys(SESEND)}$	V_{BUS} session end comparator hysteresis		-	150	-	mV
$V_{th(SESSVLD)}$	V_{BUS} session valid comparator threshold		0.8	-	2.0	V
$V_{hys(SESSVLD)}$	V_{BUS} session valid comparator hysteresis		-	200	-	mV
$V_{th(BSESSVLD)}$	V_{BUS} session valid comparator threshold	for the B-device	2.0	-	4.0	V
$V_{hys(BSESSVLD)}$	V_{BUS} session valid comparator hysteresis	for the B-device	-	200	-	mV
E	efficiency when loaded	$I_{LOAD} = 8\text{ mA}$; $V_{BAT} = 3\text{ V}$	-	75	-	%
Resistance						
$R_{VBUS(PU)}$	V_{BUS} pull-up resistor	connect to $V_{REG(3V3)}$ when $VBUS_CHRG = 1$	460	-	1000	Ω
$R_{VBUS(PD)}$	V_{BUS} pull-down resistor	connect to GND when $VBUS_DISCHRG = 1$	660	-	1200	Ω
$R_{VBUS(IDLE_A)}$	V_{BUS} idle impedance for A-device	ID pin connected to GND	40	-	100	k Ω

17. Dynamic characteristics

Table 48: Dynamic characteristics: reset and clock

$V_{BAT} = 2.7\text{ V to }4.5\text{ V}$; $V_{DD_LGC} = 1.65\text{ V to }3.6\text{ V}$; $T_{amb} = -40\text{ }^{\circ}\text{C to }+85\text{ }^{\circ}\text{C}$; unless otherwise specified.

Symbol	Parameter	Conditions	Min	Typ	Max	Unit
Reset						
$t_{W(\text{RESET_N})}$	pulse width on input RESET_N		10	-	-	μs
Internal clock						
f_{clk}	clock frequency	bit GLOBAL_PWR_DN = 0	700	1000	1300	kHz

Table 49: Dynamic characteristics: digital I/O pins

$V_{BAT} = 2.7\text{ V to }4.5\text{ V}$; $V_{DD_LGC} = 1.65\text{ V to }3.6\text{ V}$; $C_L = 50\text{ pF}$; $R_{PU} = 1.5\text{ k}\Omega$ on DP to V_{TERM} ; $T_{amb} = -40\text{ }^{\circ}\text{C to }+85\text{ }^{\circ}\text{C}$; unless otherwise specified.

Symbol	Parameter	Conditions	Min	Typ	Max	Unit
t_{TOI}	bus turnaround time (OE_N/INT_N to DAT/VP and SE0/VM)	output-to-input; see Figure 19	0	-	5	ns
t_{TIO}	bus turnaround time (OE_N/INT_N to DAT/VP and SE0/VM)	input-to-output; see Figure 19	0	-	5	ns

Table 50: Dynamic characteristics: analog I/O pins DP and DM

$V_{BAT} = 2.7\text{ V to }4.5\text{ V}$; $V_{DD_LGC} = 1.65\text{ V to }3.6\text{ V}$; $C_L = 50\text{ pF}$; $R_{PU} = 1.5\text{ k}\Omega$ on DP to V_{TERM} ; $T_{amb} = -40\text{ }^{\circ}\text{C to }+85\text{ }^{\circ}\text{C}$; unless otherwise specified.

Symbol	Parameter	Conditions	Min	Typ	Max	Unit
Driver characteristics						
t_{FR}	rise time	$C_L = 50\text{ pF to }125\text{ pF}$; 10 % to 90 % of $ V_{OH} - V_{OL} $; see Figure 15	4	-	20	ns
t_{FF}	fall time	$C_L = 50\text{ pF to }125\text{ pF}$; 90 % to 10 % of $ V_{OH} - V_{OL} $; see Figure 15	4	-	20	ns
FRFM	differential rise/fall time matching (t_{FR}/t_{FF})	excluding the first transition from idle state	90	-	111.1	%
V_{CRS}	output signal crossover voltage	excluding the first transition from idle state; see Figure 16	[1] 1.3	-	2.0	V

Driver timing

$t_{PLH(\text{drv})}$	driver propagation delay (DAT/VP, SE0/VM to DP, DM)	LOW-to-HIGH; see Figure 16 and Figure 20	-	-	18	ns
$t_{PHL(\text{drv})}$	driver propagation delay (DAT/VP, SE0/VM to DP, DM)	HIGH-to-LOW; see Figure 16 and Figure 20	-	-	18	ns
t_{PHZ}	driver disable delay (OE_N/INT_N to DP, DM)	HIGH-to-OFF; see Figure 17 and Figure 21	-	-	15	ns
t_{PLZ}	driver disable delay (OE_N/INT_N to DP, DM)	LOW-to-OFF; see Figure 17 and Figure 21	-	-	15	ns
t_{PZH}	driver enable delay (OE_N/INT_N to DP, DM)	OFF-to-HIGH; see Figure 17 and Figure 21	-	-	15	ns

Table 50: Dynamic characteristics: analog I/O pins DP and DM...continued

$V_{BAT} = 2.7\text{ V to }4.5\text{ V}$; $V_{DD_LGC} = 1.65\text{ V to }3.6\text{ V}$; $C_L = 50\text{ pF}$; $R_{PU} = 1.5\text{ k}\Omega$ on DP to V_{TERM} ; $T_{amb} = -40\text{ }^\circ\text{C to }+85\text{ }^\circ\text{C}$; unless otherwise specified.

Symbol	Parameter	Conditions	Min	Typ	Max	Unit
t_{PZL}	driver enable delay (OE_N/INT_N to DP, DM)	OFF-to-LOW; see Figure 17 and Figure 21	-	-	15	ns
Receiver timing						
Differential receiver						
$t_{PLH(rcv)}$	propagation delay (DP, DM to RCV)	LOW-to-HIGH; see Figure 18 and Figure 22	-	-	15	ns
$t_{PHL(rcv)}$	propagation delay (DP, DM to RCV)	HIGH-to-LOW; see Figure 18 and Figure 22	-	-	15	ns
Single-ended receiver						
$t_{PLH(se)}$	propagation delay (DP, DM to VP and DAT/VP, VM and SE0/VM)	LOW-to-HIGH; see Figure 18 and Figure 22	-	-	18	ns
$t_{PHL(se)}$	propagation delay (DP, DM to VP and DAT/VP, VM and SE0/VM)	HIGH-to-LOW; see Figure 18 and Figure 22	-	-	18	ns

[1] Characterized only; not tested. Limits guaranteed by design.

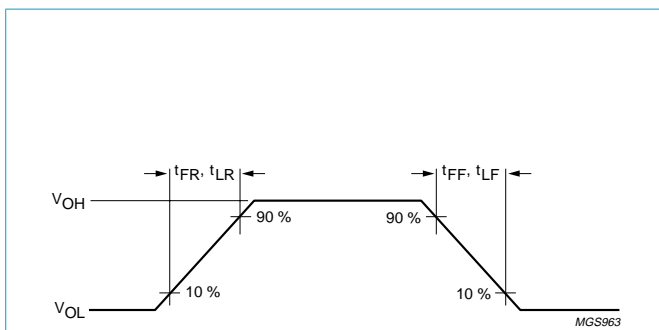

Fig 15. Rise and fall times.

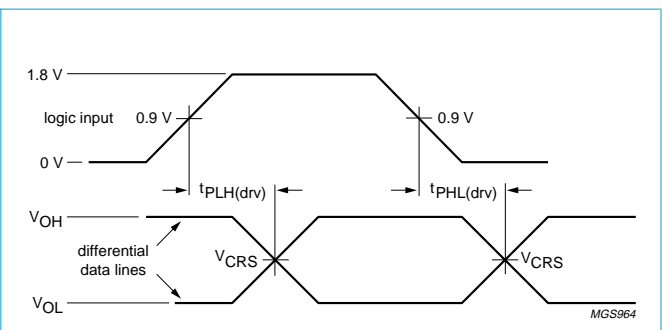

Fig 16. Timing of DAT/VP and SE0/VM to DP and DM.

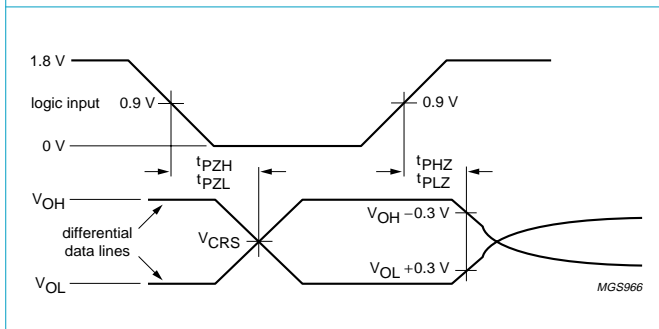

Fig 17. Timing of OE_N/INT_N to DP and DM.

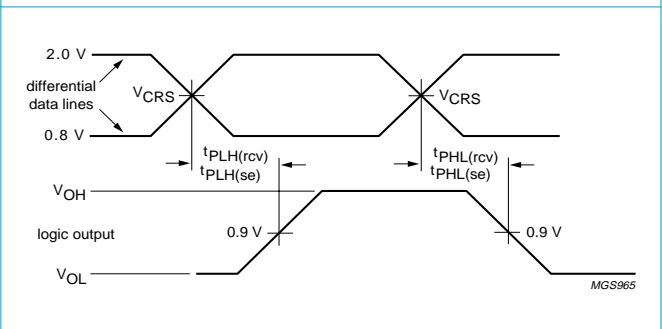

Fig 18. Timing of DP and DM to RCV, VP or DAT/VP and VM or SE0/VM.

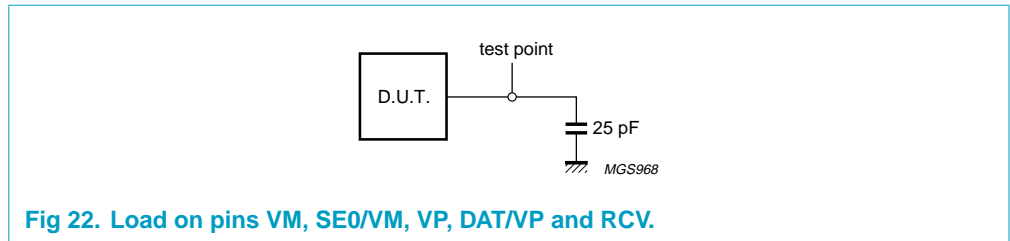
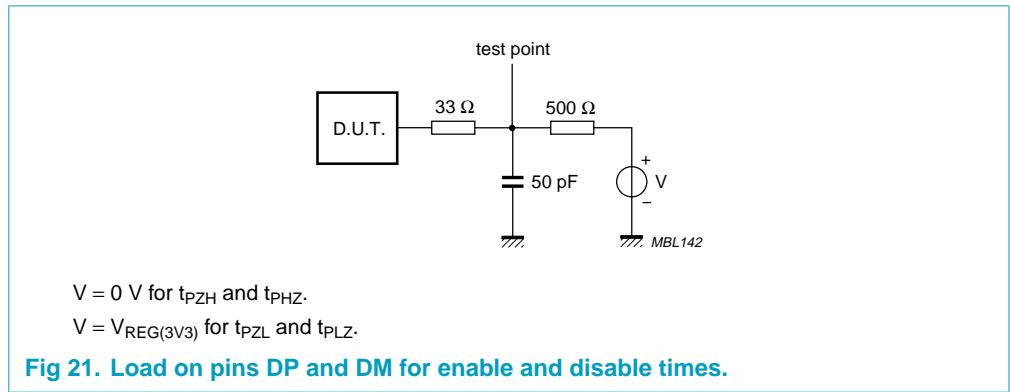
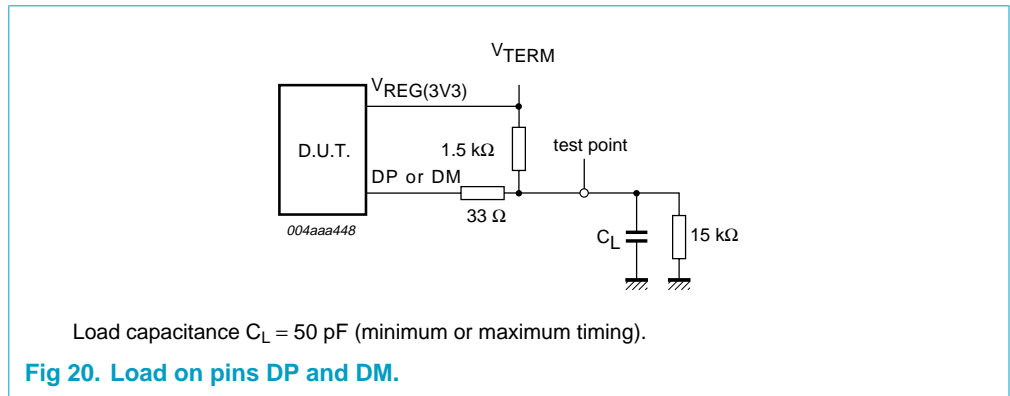
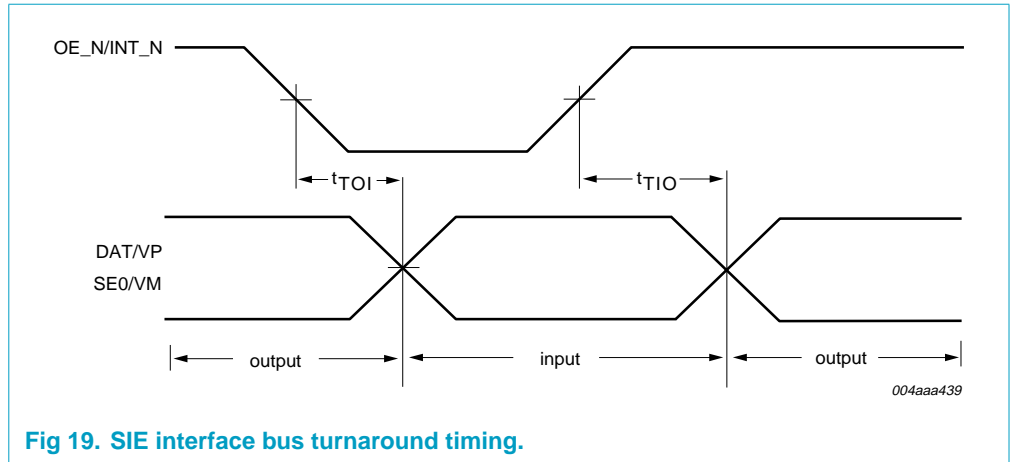

Table 51: Characteristics of I/O stages of I²C-bus lines (SDA, SCL)

Symbol	Parameter	Standard mode		Unit
		Min	Max	
f_{SCL}	SCL clock frequency	-	100	kHz
$t_{HD;STA}$	hold time for the START condition	4.0	-	μ s
t_{LOW}	LOW period of the SCL clock	4.7	-	μ s
t_{HIGH}	HIGH period of the SCL clock	4.0	-	μ s
$t_{SU;STA}$	set-up time for the START condition	4.7	-	μ s
$t_{SU;DAT}$	data set-up time	250	-	ns
$t_{HD;DAT}$	data hold time	0	-	μ s
t_r	rise time of SDA and SCL signals	-	1000	ns
t_f	fall time of SDA and SCL signals	-	300	ns
$t_{SU;STO}$	set-up time for the STOP condition	4.0	-	μ s
t_{BUF}	bus free time between a STOP and START condition	4.7	-	μ s

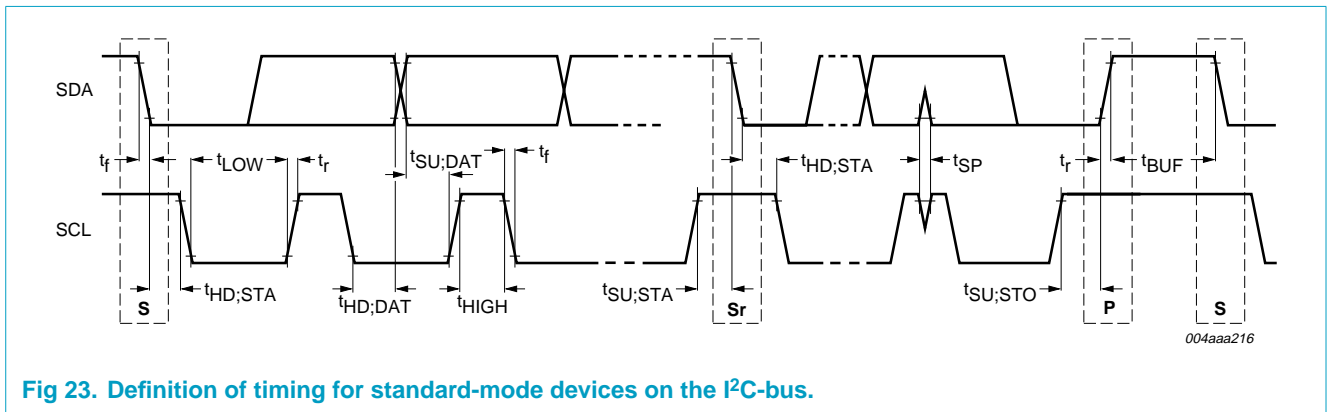
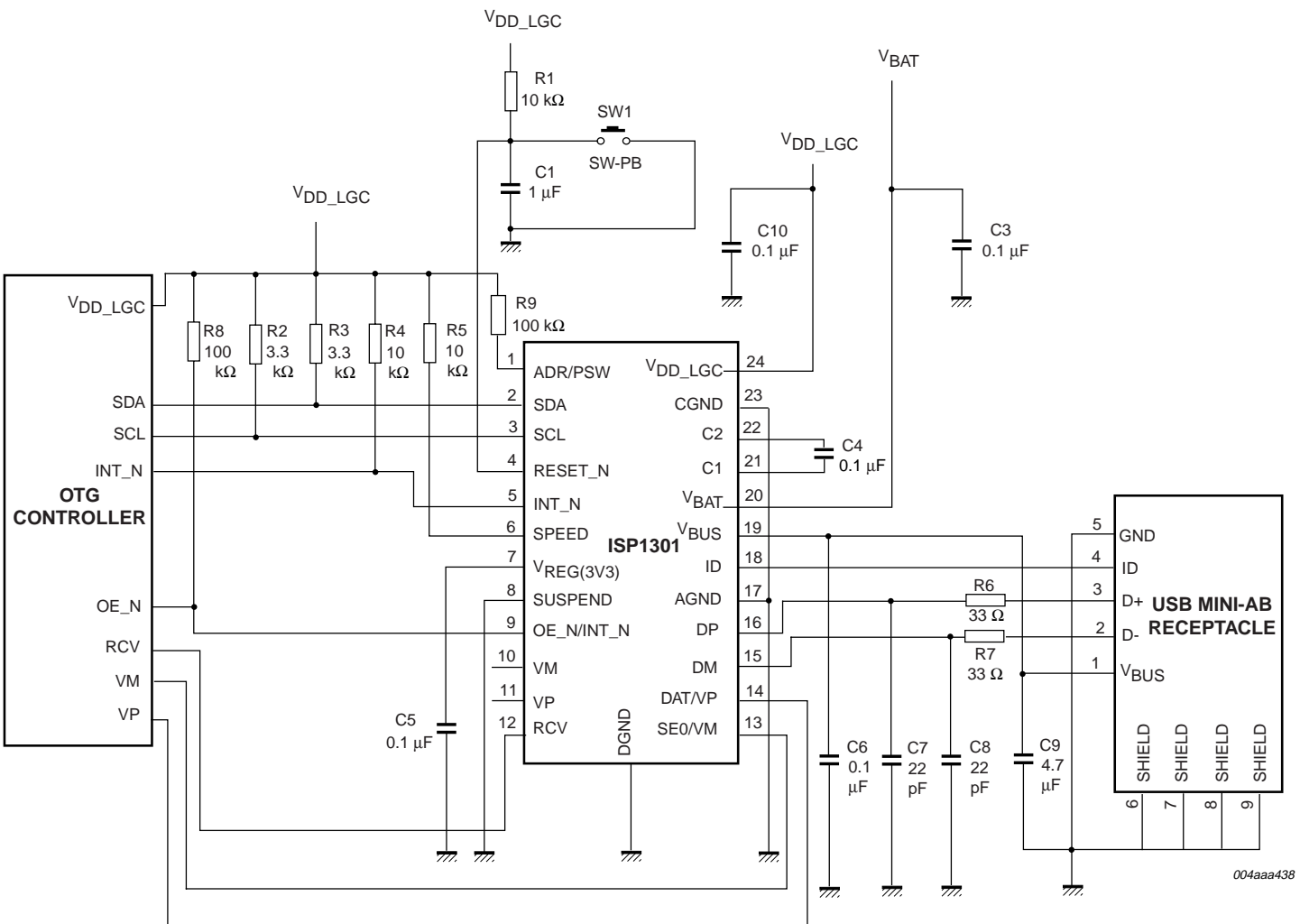

Fig 23. Definition of timing for standard-mode devices on the I²C-bus.



004aaa438

Fig 25. Application diagram for the OTG controller with VP_VM SIE interface.

19. Package outline

HVQFN24: plastic thermal enhanced very thin quad flat package; no leads; 24 terminals; body 4 x 4 x 0.85 mm

SOT616-1

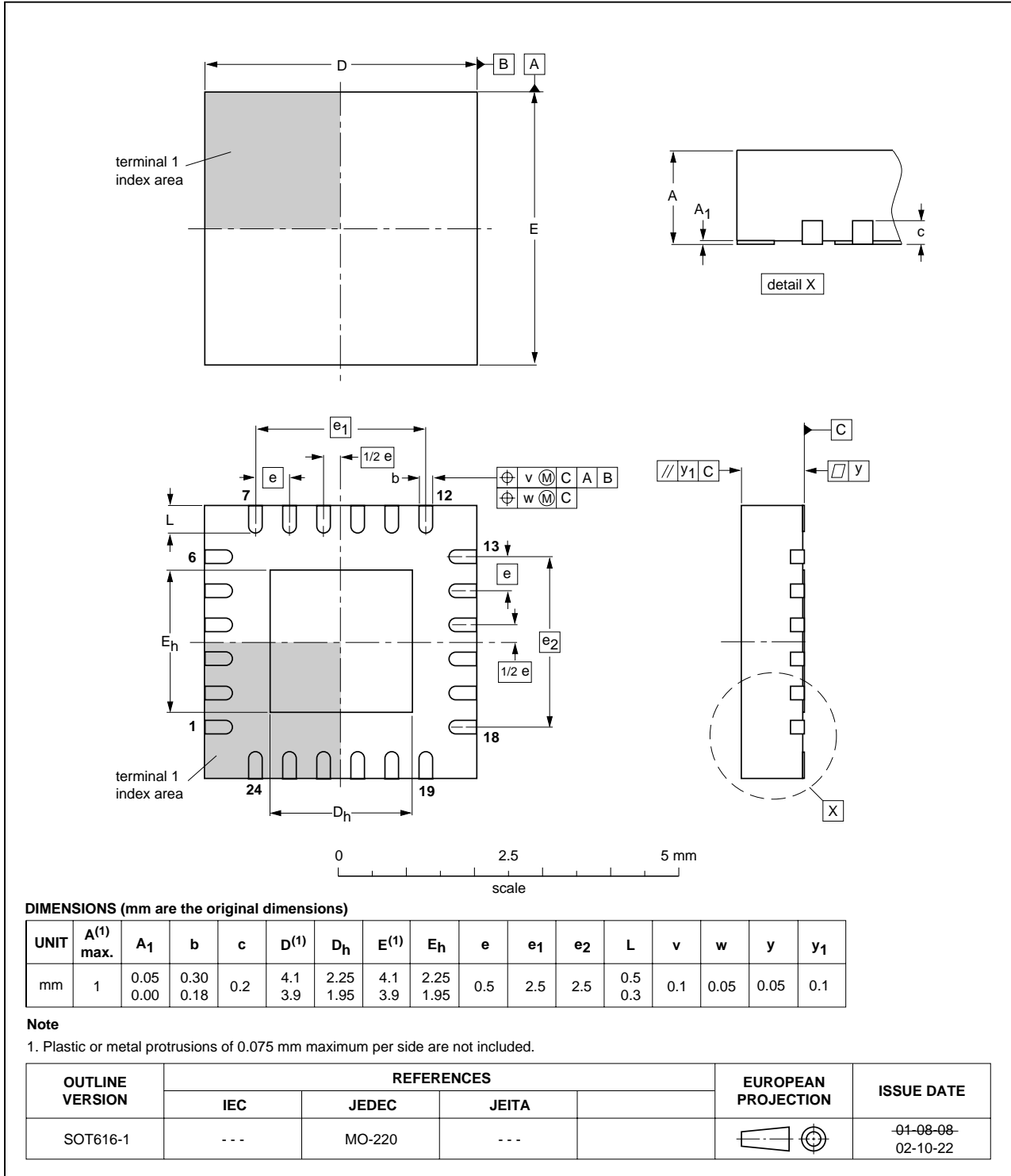

Fig 26. HVQFN24 package outline.

20. Soldering

20.1 Introduction to soldering surface mount packages

This text gives a very brief insight to a complex technology. A more in-depth account of soldering ICs can be found in our *Data Handbook IC26; Integrated Circuit Packages* (document order number 9398 652 90011).

There is no soldering method that is ideal for all surface mount IC packages. Wave soldering can still be used for certain surface mount ICs, but it is not suitable for fine pitch SMDs. In these situations reflow soldering is recommended. In these situations reflow soldering is recommended.

20.2 Reflow soldering

Reflow soldering requires solder paste (a suspension of fine solder particles, flux and binding agent) to be applied to the printed-circuit board by screen printing, stencilling or pressure-syringe dispensing before package placement. Driven by legislation and environmental forces the worldwide use of lead-free solder pastes is increasing.

Several methods exist for reflowing; for example, convection or convection/infrared heating in a conveyor type oven. Throughput times (preheating, soldering and cooling) vary between 100 and 200 seconds depending on heating method.

Typical reflow peak temperatures range from 215 to 270 °C depending on solder paste material. The top-surface temperature of the packages should preferably be kept:

- below 225 °C (SnPb process) or below 245 °C (Pb-free process)
 - for all BGA, HTSSON..T and SSOP..T packages
 - for packages with a thickness ≥ 2.5 mm
 - for packages with a thickness < 2.5 mm and a volume ≥ 350 mm³ so called thick/large packages.
- below 240 °C (SnPb process) or below 260 °C (Pb-free process) for packages with a thickness < 2.5 mm and a volume < 350 mm³ so called small/thin packages.

Moisture sensitivity precautions, as indicated on packing, must be respected at all times.

20.3 Wave soldering

Conventional single wave soldering is not recommended for surface mount devices (SMDs) or printed-circuit boards with a high component density, as solder bridging and non-wetting can present major problems.

To overcome these problems the double-wave soldering method was specifically developed.

If wave soldering is used the following conditions must be observed for optimal results:

- Use a double-wave soldering method comprising a turbulent wave with high upward pressure followed by a smooth laminar wave.

- For packages with leads on two sides and a pitch (e):
 - larger than or equal to 1.27 mm, the footprint longitudinal axis is **preferred** to be parallel to the transport direction of the printed-circuit board;
 - smaller than 1.27 mm, the footprint longitudinal axis **must** be parallel to the transport direction of the printed-circuit board.

The footprint must incorporate solder thieves at the downstream end.

- For packages with leads on four sides, the footprint must be placed at a 45° angle to the transport direction of the printed-circuit board. The footprint must incorporate solder thieves downstream and at the side corners.

During placement and before soldering, the package must be fixed with a droplet of adhesive. The adhesive can be applied by screen printing, pin transfer or syringe dispensing. The package can be soldered after the adhesive is cured.

Typical dwell time of the leads in the wave ranges from 3 to 4 seconds at 250 °C or 265 °C, depending on solder material applied, SnPb or Pb-free respectively.

A mildly-activated flux will eliminate the need for removal of corrosive residues in most applications.

20.4 Manual soldering

Fix the component by first soldering two diagonally-opposite end leads. Use a low voltage (24 V or less) soldering iron applied to the flat part of the lead. Contact time must be limited to 10 seconds at up to 300 °C.

When using a dedicated tool, all other leads can be soldered in one operation within 2 to 5 seconds between 270 and 320 °C.

20.5 Package related soldering information

Table 52: Suitability of surface mount IC packages for wave and reflow soldering methods

Package ^[1]	Soldering method	
	Wave	Reflow ^[2]
BGA, HTSSON..T ^[3] , LBGA, LFBGA, SQFP, SSOP..T ^[3] , TFBGA, USON, VFBGA	not suitable	suitable
DHVQFN, HBCC, HBGA, HLQFP, HSO, HSOP, HSQFP, HSSON, HTQFP, HTSSOP, HVQFN, HVSON, SMS	not suitable ^[4]	suitable
PLCC ^[5] , SO, SOJ	suitable	suitable
LQFP, QFP, TQFP	not recommended ^{[5][6]}	suitable
SSOP, TSSOP, VSO, VSSOP	not recommended ^[7]	suitable
CWQCCN..L ^[8] , PMFP ^[9] , WQCCN..L ^[8]	not suitable	not suitable

[1] For more detailed information on the BGA packages refer to the *(LF)BGA Application Note* (AN01026); order a copy from your Philips Semiconductors sales office.

[2] All surface mount (SMD) packages are moisture sensitive. Depending upon the moisture content, the maximum temperature (with respect to time) and body size of the package, there is a risk that internal or external package cracks may occur due to vaporization of the moisture in them (the so called popcorn effect). For details, refer to the Drypack information in the *Data Handbook IC26; Integrated Circuit Packages; Section: Packing Methods*.

- [3] These transparent plastic packages are extremely sensitive to reflow soldering conditions and must on no account be processed through more than one soldering cycle or subjected to infrared reflow soldering with peak temperature exceeding $217\text{ }^{\circ}\text{C} \pm 10\text{ }^{\circ}\text{C}$ measured in the atmosphere of the reflow oven. The package body peak temperature must be kept as low as possible.
- [4] These packages are not suitable for wave soldering. On versions with the heatsink on the bottom side, the solder cannot penetrate between the printed-circuit board and the heatsink. On versions with the heatsink on the top side, the solder might be deposited on the heatsink surface.
- [5] If wave soldering is considered, then the package must be placed at a 45° angle to the solder wave direction. The package footprint must incorporate solder thieves downstream and at the side corners.
- [6] Wave soldering is suitable for LQFP, QFP and TQFP packages with a pitch (e) larger than 0.8 mm; it is definitely not suitable for packages with a pitch (e) equal to or smaller than 0.65 mm.
- [7] Wave soldering is suitable for SSOP, TSSOP, VSO and VSOP packages with a pitch (e) equal to or larger than 0.65 mm; it is definitely not suitable for packages with a pitch (e) equal to or smaller than 0.5 mm.
- [8] Image sensor packages in principle should not be soldered. They are mounted in sockets or delivered pre-mounted on flex foil. However, the image sensor package can be mounted by the client on a flex foil by using a hot bar soldering process. The appropriate soldering profile can be provided on request.
- [9] Hot bar soldering or manual soldering is suitable for PMFP packages.

21. Revision history

Table 53: Revision history

Rev	Date	CPCN	Description
01	20040414	-	Product data (9397 750 11355).

22. Data sheet status

Level	Data sheet status ^[1]	Product status ^{[2][3]}	Definition
I	Objective data	Development	This data sheet contains data from the objective specification for product development. Philips Semiconductors reserves the right to change the specification in any manner without notice.
II	Preliminary data	Qualification	This data sheet contains data from the preliminary specification. Supplementary data will be published at a later date. Philips Semiconductors reserves the right to change the specification without notice, in order to improve the design and supply the best possible product.
III	Product data	Production	This data sheet contains data from the product specification. Philips Semiconductors reserves the right to make changes at any time in order to improve the design, manufacturing and supply. Relevant changes will be communicated via a Customer Product/Process Change Notification (CPCN).

[1] Please consult the most recently issued data sheet before initiating or completing a design.

[2] The product status of the device(s) described in this data sheet may have changed since this data sheet was published. The latest information is available on the Internet at URL <http://www.semiconductors.philips.com>.

[3] For data sheets describing multiple type numbers, the highest-level product status determines the data sheet status.

23. Definitions

Short-form specification — The data in a short-form specification is extracted from a full data sheet with the same type number and title. For detailed information see the relevant data sheet or data handbook.

Limiting values definition — Limiting values given are in accordance with the Absolute Maximum Rating System (IEC 60134). Stress above one or more of the limiting values may cause permanent damage to the device. These are stress ratings only and operation of the device at these or at any other conditions above those given in the Characteristics sections of the specification is not implied. Exposure to limiting values for extended periods may affect device reliability.

Application information — Applications that are described herein for any of these products are for illustrative purposes only. Philips Semiconductors make no representation or warranty that such applications will be suitable for the specified use without further testing or modification.

24. Disclaimers

Life support — These products are not designed for use in life support appliances, devices, or systems where malfunction of these products can reasonably be expected to result in personal injury. Philips Semiconductors customers using or selling these products for use in such applications do so at their own risk and agree to fully indemnify Philips Semiconductors for any damages resulting from such application.

Right to make changes — Philips Semiconductors reserves the right to make changes in the products - including circuits, standard cells, and/or software - described or contained herein in order to improve design and/or performance. When the product is in full production (status 'Production'), relevant changes will be communicated via a Customer Product/Process Change Notification (CPCN). Philips Semiconductors assumes no responsibility or liability for the use of any of these products, conveys no licence or title under any patent, copyright, or mask work right to these products, and makes no representations or warranties that these products are free from patent, copyright, or mask work right infringement, unless otherwise specified.

25. Licenses

Purchase of Philips I²C components



Purchase of Philips I²C components conveys a license under the Philips' I²C patent to use the components in the I²C system provided the system conforms to the I²C specification defined by Philips. This specification can be ordered using the code 9398 393 40011.

26. Trademarks

I²C-bus — is a trademark of Koninklijke Philips Electronics N.V.

Contact information

For additional information, please visit <http://www.semiconductors.philips.com>.

For sales office addresses, send e-mail to: sales.addresses@www.semiconductors.philips.com.

Fax: +31 40 27 24825

Contents

1	General description	1	11.1.1	Device identification registers.	17
2	Features	1	11.1.2	Mode control registers	18
3	Applications	2	11.1.3	OTG registers.	19
4	Abbreviations	2	11.1.4	Interrupt related registers.	20
5	Ordering information	2	11.2	Interrupts	22
6	Block diagram	3	11.3	Autoconnect	23
7	Pinning information	4	12	Clock wake up scheme	24
7.1	Pinning	4	12.1	Power down event	24
7.2	Pin description	5	12.2	Clock wake up events.	24
8	Functional description	7	13	I²C-bus protocol	26
8.1	Serial controller.	7	13.1	I ² C-bus byte transfer format	26
8.2	V _{BUS} charge pump	7	13.2	I ² C-bus device address	26
8.3	V _{BUS} comparators	7	13.3	Write format	26
8.3.1	V _{BUS} valid comparator	7	13.3.1	One-byte write	26
8.3.2	Session valid comparator	7	13.3.2	Multiple-byte write	27
8.3.3	Session end comparator.	7	13.4	Read format	28
8.4	ID detector	8	13.4.1	Current address read	28
8.5	Pull-up and pull-down resistors.	8	13.4.2	Random address read	29
8.6	USB transceiver (ATX)	8	14	Limiting values	31
8.7	3.3 V DC-DC regulator	8	15	Recommended operating conditions	31
8.8	Car kit interrupt detector	8	16	Static characteristics	32
8.9	Detailed description of pins	9	17	Dynamic characteristics	35
8.9.1	ADR/PSW	9	18	Application information	39
8.9.2	SCL and SDA	9	19	Package outline	41
8.9.3	RESET_N	9	20	Soldering	42
8.9.4	INT_N	9	20.1	Introduction to soldering surface mount	
8.9.5	OE_N/INT_N.	10		packages	42
8.9.6	SE0/VM, DAT/VP, RCV, VM and VP	10	20.2	Reflow soldering.	42
8.9.7	DP and DM	10	20.3	Wave soldering.	42
8.9.8	ID	10	20.4	Manual soldering	43
8.9.9	V _{BUS}	10	20.5	Package related soldering information.	43
8.9.10	V _{BAT}	11	21	Revision history	44
8.9.11	C1 and C2.	11	22	Data sheet status	45
8.9.12	V _{DD_LGC}	11	23	Definitions	45
8.9.13	AGND, CGND and DGND.	11	24	Disclaimers	45
9	Modes of operation	12	25	Licenses	45
9.1	Power modes	12	26	Trademarks	45
9.2	Direct I ² C-bus mode	12			
9.3	USB modes.	12			
9.4	Transparent modes	13			
9.4.1	Transparent general-purpose buffer mode	13			
9.4.2	Transparent UART mode	13			
9.4.3	Summary tables	13			
10	USB transceiver	15			
10.1	Differential driver.	15			
10.2	Differential receiver.	15			
11	Serial controller	17			
11.1	Register map	17			



PHILIPS

Let's make things better.