

T1/E1/CEPT/ISDN-PRI INTERFACE MODULES

Dual Surface Mount Transformer Modules, 1500 Vrms, Extended Temperature Range



- ⊕ Optimized for enhanced EMC performance
- ⊕ Extended temperature range
- ⊕ Dual SMT package contains transformers with Common Mode Chokes on both transmit and receive channels
- ⊕ Models matched to leading transceiver ICs
- ⊕ Patented Interlock Base construction for high reliability
- ⊕ Recognized to UL 1459, UL 1950, and EN 60950 – approval pending

Electrical Specifications @ 25°C

Part Number	Turns Ratio ² (Pri:Sec ± 2%)	Secondary OCL @ 25°C (mH MIN)	L _L (μH MAX)	C _{w/w} (pF MAX)	DCR Pri (Ω MAX)	Package/ Schematic	Primary Pins
EXTENDED TEMPERATURE RANGE MODELS¹ – OPERATING TEMPERATURE -40°C TO +85°C							
T1207	1CT:2CT & 1CT:2CT	1.20	.60	25	.60	AN/1	1-3, 4-6
T1208	1CT:2CT & 1CT:1.36CT	1.20	.60	30	.70	AN/1	1-3, 4-6
T1209	1CT:1.15CT & 1CT:2CT	1.20	.60	35	.80	AN/1	1-3, 4-6
T1210	1CT:1.26CT & 1CT:2CT	1.20	.60	30	.80	AN/1	1-3, 4-6
T1220	1CT:1CT & 1CT:1CT	1.20	.60	35	.90	AN/1	1-3, 4-6
T1211	1CT:1.15CT & 1CT:1.15CT	1.20	.60	35	.80	AN/1	1-3, 4-6
T1212	1CT:1CT & 1CT:2CT	1.20	.60	35	.90	AN/1	1-3, 4-6
T1213	1CT:1.15CT & 1CT:1CT	1.20	.60	35	.90	AN/1	1-3, 4-6
T1214	1CT:1.36CT & 1CT:1.36CT	1.20	.60	30	.80	AN/1	1-3, 4-6
T1215	1CT:1.41CT & 1CT:1.41CT	1.20	.60	30	.70	AN/1	1-3, 4-6
T1216	1CT:2.3CT & 1CT:2CT	1.20	.60	25	.60	AN/1	1-3, 4-6
T1217	1CT:2.42CT & 1CT:2.42CT	1.20	.60	25	.60	AN/1	1-3, 4-6
T1218	1CT:1CT & 1CT:1.36CT	1.20	.60	35	.90	AN/1	1-3, 4-6
T1219	1CT:2.4CT & 1CT:1CT	1.20	.60	35	.90	AN/1	1-3, 4-6

Mechanical

Schematics

AN

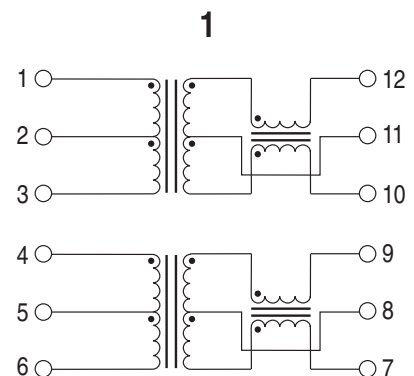
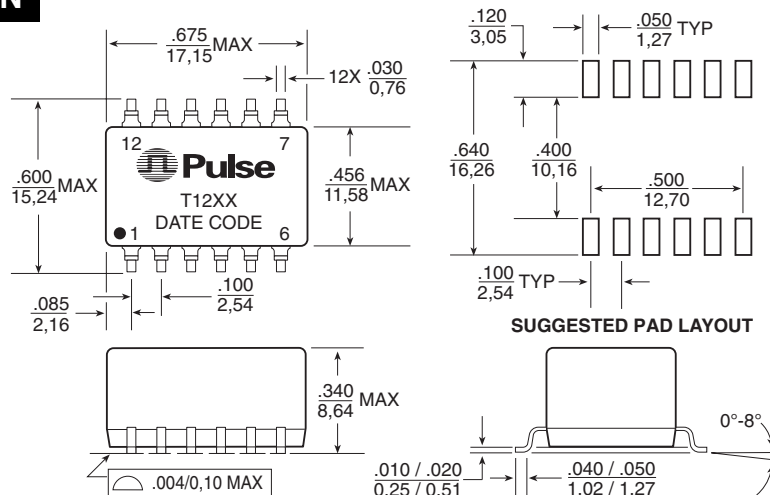

Dimensions: $\frac{\text{Inches}}{\text{mm}}$
Unless otherwise specified, all tolerances are $\pm \frac{.010}{0,25}$

Weight 4.0 grams
Tape & Reel250/reel
Tube30/tube

T1/E1/CEPT/ISDN-PRI INTERFACE MODULES Transformer Selection Guide



NOTE: For Quad Port Transceiver products, refer to data sheet **T620**.

IC Manufacturer IC Part Number	Comments	Dual SMT w/Chokes	
		Ext Temp	TX & RX
LUCENT TECHNOLOGIES			
T7288	CEPT/E1	T1208	
T7289	DS1	T1209	
T7290A	T1 & CEPT	T1208	
T7688, T7698	CEPT	T1214	
T7689, T7698	DS1	T1211	
T7690	DS1	T1211	
T7690	CEPT/E1	T1214	
T7693	CEPT	T1217	
T7693	DS1	T1207	
CIRRUS LOGIC (CRYSTAL)			
61574, 61577	T1 & E1	T1207	
61535A, 61574A, 61575, 61304A, 61305A	T1	T1209	
61535A, 61574A, 61575, 61304A, 61305A	PCM-30, 75	T1212	
61535A, 61574A, 61575, 61304A, 61305A	PCM-30, 120	T1210	
61881		T1209	
61581, 61318, 61310	T1 & E1	T1212	
61584, 61584A	IQ3	T1207	
61584, 61582, 61583	IQ5	T1211	
DALLAS			
DS2186, DS2187		T1208	
DS2151, DS2152, DS2153, DS2154, 552, 554		T1213	
DS2151, DS2152, DS2153, DS2154, 552, 554		T1218	
DS2148, Q48	3V	T1212	
DS2148, Q48	5V	T1218	
DS21352, DS21354	T1/E1	T1212	
DS21Q352 / 54, DS21Q552 / 54	T1/E1	T1212	
DS21Q352 / 54, DS21Q552 / 54	T1/E1	T1218	
EXAR			
T5650, T5620, T5675, T5681, T5683		T1207	
56L22, 56L85, C240, C260, C262, C277, 59291		T1207	
T5791, T5794, T5795, T5894, T5897, T5997		T1207	
T5793		T1210	
T7288, T5684	CEPT1	T1208	
LEVEL ONE			
LXT 300, LXT 304A, LXT 305A, LXT 307		T1207	
LXT 304A, LXT 305A	T1	T1209	
LXT 304A, LXT 305A	PCM-30 75	T1212	
LXT 304A, LXT 305A	PCM-30 120	T1210	
LXT 304A, LXT 305A	DSX-1, D4	T1216	
LXT 310/311/317/318/319		T1212	
LXT 331, LXT 335	T1/E1	T1212	
LXT 331, LXT 334	T1	T1213	
LXT 331, LXT 332		T1209	
LXT 331, LXT 332		T1207	
LXT 331, LXT 332, LXT 351, LXT 360	T1	T1216	
LXT 350/351/360/361/370		T1212	
LXT 380, LXT 381		T1212	
LXT 384, LXT 386, LXT 388		T1207	
PMC-SIERRA			
PM4341, PM6341		T1208	
PM4351	COMET	T1217	
ROCKWELL/BROOKTREE (CONEXANT)			
BT8510		T1207	
R8069, R8069A, R8069B		T1207	
BT8370, BT8375, BT8376		T1218	
INFINEON (SIEMENS)			
PEB 2235, PEB 2235A1, PEB 2235B1	T1/CEPT	T1215	
PEB 2254, PEB 2255		T1215	
PEB 22504, PEB 22554	3V	T1219	
VLSI			
VP14Q574	T1	T1209	
VP14Q574	E1	T1210	

Notes From Tables

- Extended Temperature Range Models** — For extended temperature range transformers (-40°C to +85°C operating temperature range), OCL (Open Circuit Inductance) is specified at both -40°C and +25°C. At -40°C, OCL is 600 µH minimum. All other parameters are specified at +25°C only.
- Turns ratio is specified primary: secondary (CT = Center Tap).
- Standard packaging for the surface mount package is anti-static tubes. Optional Tape & Reel packaging can be ordered by adding a "T" suffix to the part number, (i.e. T1220T).

Application Notes

- ET Product** — All coils have an ET product of 10 V-µsec minimum.
- Flammability** — Materials used in the products are recognized as UL94-VO approved. Products meet the requirements of IEC 695-2-2 (Needle Flame Test).
- Balance Characteristics** — The transformers meet the requirements for longitudinal balance of FCC part 68.
- Common Mode Rejection Ratio** — the CMRR for all transformers is better than 50 dB at 1 MHz. A typical test circuit is shown below.
- Crosstalk Attenuation** — In the packages which contain transmit and receive transformers side by side, sufficient crosstalk attenuation is achieved by the inherent characteristics of the toroid cores as well as by their proper positioning. The crosstalk attenuation is typically 65 dB or better. This result was established with the test circuit shown below.
- Return Loss** — ITU-T G.703 and European national regulatory documents specify minimum return loss levels. The transformers will allow these limits to be complied within the situations where they are applicable.

Frequency	50-100 KHz	100 KHz-2 MHz	2-3 MHz
Return Loss			
XMIT	9 dB	15 dB	11 dB
RCV	12 dB	18 dB	14 dB

- Surge Voltage Capability** — All transformers and chokes meet surge voltage tests according to the most stringent regulatory documents, when used with the proper voltage and current suppression devices:

Metallic Voltage: 800 V peak, 10/560 µsec
Longitudinal Voltage: 2,400 V peak, 10/700 µsec

- Isolation Voltage** — 100% of transformers are tested during production to the specified 1500 Vrms isolation voltage level.
- General Information** — The transformers are specifically designed for use in 1.544 Mbps (T1), 2.048 Mbps (CEPT) and ISDN Primary rate (PRI) interface applications. They are matched to the majority of the line interface transceiver ICs currently available. Use of the proper transformer allows the interface circuit to comply with ITU-T G.703 and other standards regarding pulse waveform, return loss, and balance.

For More Information :

UNITED STATES (Worldwide)	UNITED KINGDOM (Northern Europe)	FRANCE (Southern Europe)	SINGAPORE (Southern Asia)	TAIWAN, R.O.C. (Northern Asia)	DISTRIBUTOR
12220 World Trade Drive San Diego, CA 92128 U.S.A. http://www.pulseeng.com TEL: 858 674 8100 FAX: 858 674 8262	1 & 2 Huxley Road The Surrey Research Park Guildford, Surrey GU2 5RE United Kingdom TEL: 44 1483 401700 FAX: 44 1483 401701	Zone Industrielle F-39270 Orgelet France TEL: 33 3 84 35 04 04 FAX: 33 3 84 25 46 41	150 Kampong Ampat #07-01/02 KA Centre Singapore 368324 TEL: 65 287 8998 FAX: 65 280 0080	3F-4, No. 81, Sec. 1 HsinTai Wu Road Hsi-Chih, Taipei Hsien Taiwan, R.O.C. Tel: 886 2 2698 0228 FAX: 886 2 2698 0948	

Performance warranty of products offered on this data sheet is limited to the parameters specified. Data is subject to change without notice. Other brand and product names mentioned herein may be products and/or registered trademarks of their respective owners.