

IL211AT/IL212AT/IL213AT PHOTOTRANSISTOR SMALL OUTLINE SURFACE MOUNT OPTOCOUPLER

FEATURES

- **High Current Transfer Ratio**
IL211AT—20% Minimum
IL212AT—50% Minimum
IL213AT—100% Minimum
- **Isolation Voltage, 2500 VAC_{RMS}**
- **Electrical Specifications Similar to Standard 6 Pin Coupler**
- **Industry Standard SOIC-8 Surface Mountable Package**
- **Standard Lead Spacing, .05"**
- **Available in Tape and Reel (suffix T) (Conforms to EIA Standard RS481A)**
- **Compatible with Dual Wave, Vapor Phase and IR Reflow Soldering**
- **Underwriters Lab File #E52744 (Code Letter P)**

DESCRIPTION

The IL211AT/212AT/213AT are optically coupled pairs with a Gallium Arsenide infrared LED and a silicon NPN phototransistor. Signal information, including a DC level, can be transmitted by the device while maintaining a high degree of electrical isolation between input and output. The IL211AT//212AT/213AT comes in a standard SOIC-8 small outline package for surface mounting which makes it ideally suited for high density applications with limited space. In addition to eliminating through-holes requirements, this package conforms to standards for surface mounted devices.

A choice of 20, 50, and 100% minimum CTR at $I_F=10$ mA makes these optocouplers suitable for a variety of different applications.

Maximum Ratings

Emitter

Peak Reverse Voltage 6.0 V
 Continuous Forward Current 60 mA
 Power Dissipation at 25°C 90 mW
 Derate Linearly from 25°C 1.2 mW/°C

Detector

Collector-Emitter Breakdown Voltage 30 V
 Emitter-Collector Breakdown Voltage 7 V
 Collector-Base Breakdown Voltage 70 V
 Power Dissipation 150 mW
 Derate Linearly from 25°C 2.0 mW/°C

Package

Total Package Dissipation at 25°C Ambient (LED + Detector) 280 mW
 Derate Linearly from 25°C 3.3 mW/°C
 Storage Temperature -55°C to +150°C
 Operating Temperature -55°C to +100°C
 Soldering Time at 260°C 10 sec.

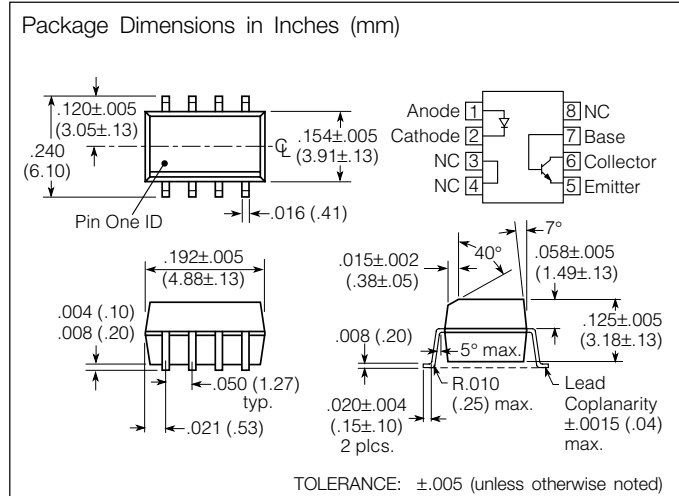

Characteristics (T_A=25°C)

	Symbol	Min.	Typ.	Max.	Unit	Condition
Emitter						
Forward Voltage	V _F		1.3	1.5	V	I _F =10 mA
Reverse Current	I _R		0.1	100	µA	V _R =6.0 V
Capacitance	C _O		25		pF	V _R =0
Detector						
Breakdown Voltage	BV _{CEO}	30			V	I _C =10 µA
	BV _{ECO}	7			V	I _E =10 µA
Collector-Emitter Dark Current	I _{CEOdark}	5	50		nA	V _{CE} =10 V, I _F =0
Collector-Emitter Capacitance	C _{CE}	10			pF	V _{CE} =0
Package						
DC Current Transfer	CTR _{DC}				%	I _F =10 mA, V _{CE} =5 V
IL211AT		20	50			
IL212AT		50	80			
IL213AT		100	130			
Collector-Emitter Saturation Voltage	V _{CE sat}			0.4		I _F =10 mA, I _C =2.0 mA
Isolation Test Voltage	V _{IO}	2500				VAC _{RMS}
Capacitance, Input to Output	C _{IO}	0.5			pF	
Resistance, Input to Output	R _{IO}	100			GΩ	
Switching Time	t _{ON} , t _{OFF}	3.0			µs	I _C =2 mA, R _E =100 Ω, V _{CE} =10 V

Specifications subject to change.

Figure 1. Forward voltage versus forward current

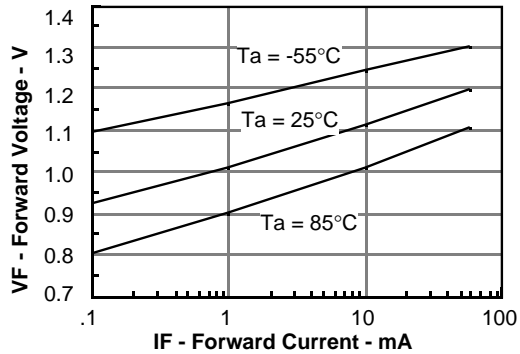

Figure 2. Normalized non-saturated and saturated CTRce versus LED current

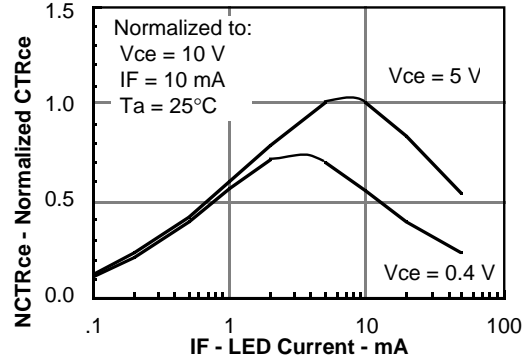

Figure 3. Collector-emitter current versus LED current

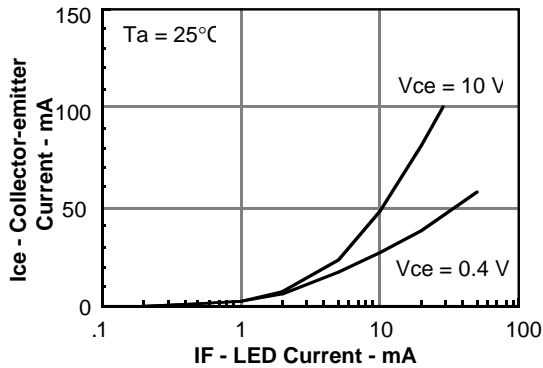

Figure 4. Normalized collector-base photocurrent versus LED current

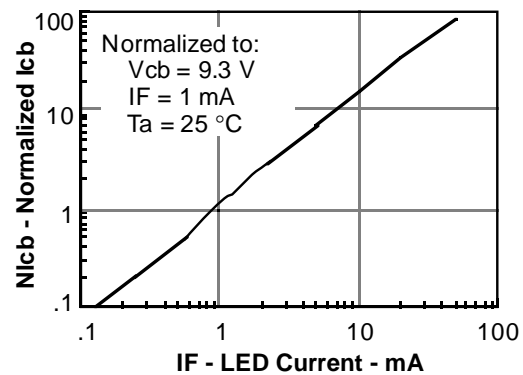

Figure 5. Normalized collector-base photocurrent versus LED current

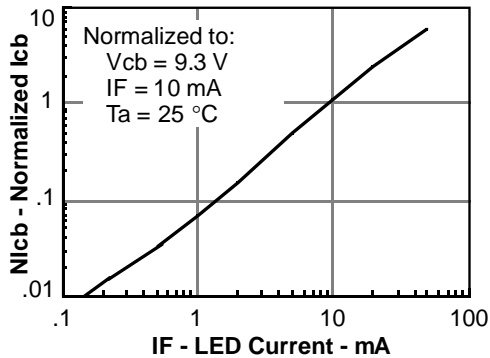

Figure 6. Collector-base photocurrent versus LED current

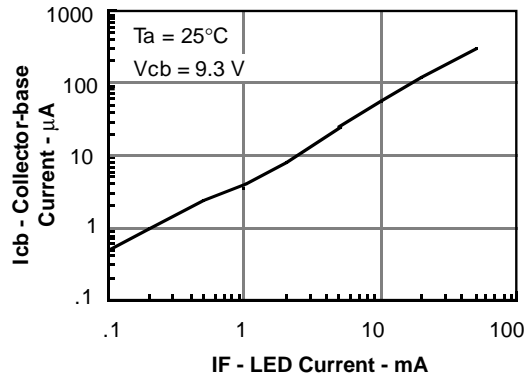

Figure 7. Collector-emitter leakage current versus temperature

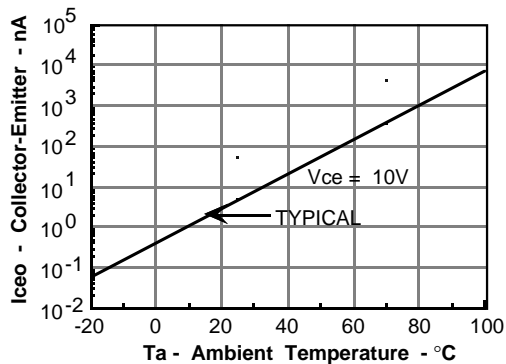

Figure 8. Normalized saturated HFE versus base current and temperature

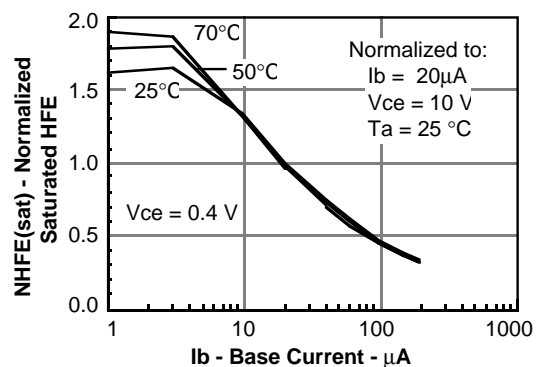

Figure 9. Typical switching characteristics versus base resistance (saturated operation)

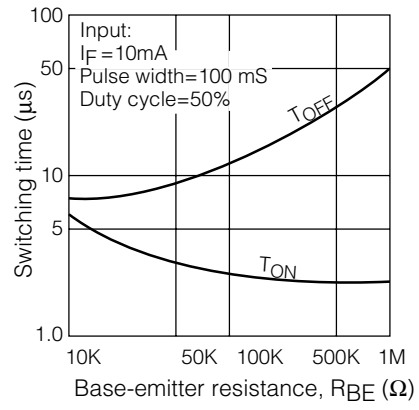

Figure 10. Typical switching times versus load resistance

