



Integrated Device Technology, Inc.

# CMOS SUPERSYNC FIFO™ 8,192 x 18, 16,384 x 18

IDT72255  
IDT72265

## FEATURES:

- 8,192 x 18-bit storage capacity (IDT72255)
- 16,384 x 18-bit storage capacity (IDT72265)
- 10ns read/write cycle time (8ns access time)
- Retransmit Capability
- Auto power down reduces power consumption
- Master Reset clears entire FIFO, Partial Reset clears data, but retains programmable settings
- Empty, Full and Half-full flags signal FIFO status
- Programmable Almost Empty and Almost Full flags, each flag can default to one of two preselected offsets
- Program partial flags by either serial or parallel means
- Select IDT Standard timing (using EF and FF flags) or First Word Fall Through timing (using OR and IR flags)
- Easily expandable in depth and width
- Independent read and write clocks (permit simultaneous reading and writing with one clock signal)
- Available in the 64-pin Thin Quad Flat Pack (TQFP), 64-pin Slim Thin Quad Flat Pack (STQFP) and the 68-pin Pin Grid Array (PGA)
- Output enable puts data outputs into high impedance
- High-performance submicron CMOS technology
- Industrial temperature range (-40°C to +85°C) is available, tested to military electrical specifications

## DESCRIPTION:

The IDT72255/72265 are monolithic, CMOS, high capacity, high speed, low power First-In, First-Out (FIFO) memories with clocked read and write controls. These FIFOs are applicable for a wide variety of data buffering needs, such as optical disk controllers, local area networks (LANs), and inter-processor communication.

Both FIFOs have an 18-bit input port (D<sub>n</sub>) and an 18-bit output port (Q<sub>n</sub>). The input port is controlled by a free-running clock (WCLK) and a data input enable pin (WEN). Data is written into the synchronous FIFO on every clock when WEN is asserted. The output port is controlled by another clock pin (RCLK) and enable pin (REN). The read clock can be tied to the write clock for single clock operation or the two clocks can run asynchronously for dual clock operation. An output enable pin (OE) is provided on the read port for three-state control of the outputs.

The IDT72255/72265 have two modes of operation: In the *IDT Standard Mode*, the first word written to the FIFO is deposited into the memory array. A read operation is required to access that word. In the *First Word Fall Through Mode* (FWFT), the first word written to an empty FIFO appears

## FUNCTIONAL BLOCK DIAGRAM

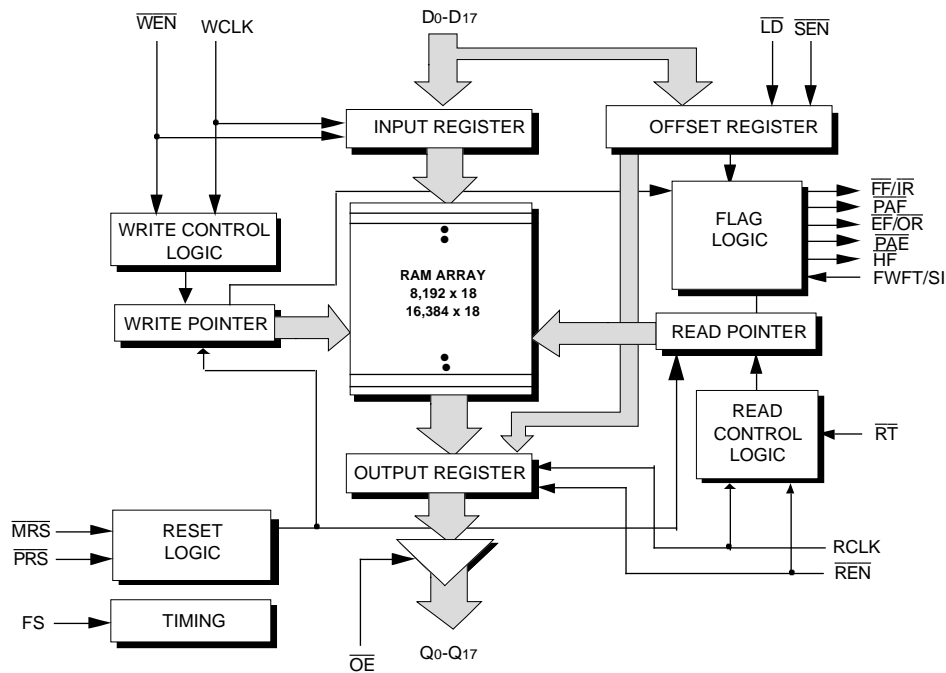

3037 drw 01

SyncFIFO is a trademark and the IDT logo is a registered trademark of Integrated Device Technology, Inc.

## MILITARY AND COMMERCIAL TEMPERATURE RANGES

MAY 1997

automatically on the outputs, no read operation required. The state of the FWFT/SI pin during Master Reset determines the mode in use.

The IDT72255/72265 FIFOs have five flag functions,  $\overline{EF}/\overline{OR}$  (Empty Flag or Output Ready),  $\overline{FF}/\overline{IR}$  (Full Flag or Input Ready), and  $\overline{HF}$  (Half-full Flag). The  $\overline{EF}$  and  $\overline{FF}$  functions are selected in the IDT Standard Mode.

The  $\overline{IR}$  and  $\overline{OR}$  functions are selected in the First Word Fall Through Mode.  $\overline{IR}$  indicates that the FIFO has free space to receive data.  $\overline{OR}$  indicates that data contained in the FIFO is available for reading.

$\overline{HF}$  is a flag whose threshold is fixed at the half-way point in memory. This flag can always be used irrespective of mode.

$\overline{PAE}$ ,  $\overline{PAF}$  can be programmed independantly to any point in memory. They, also, can be used irrespective of mode. Programmable offsets determine the flag threshold and can be loaded by two methods: parallel or serial. Two default offset settings are also provided, such that  $\overline{PAE}$  can be set at 127 or 1023 locations from the empty boundary and the  $\overline{PAF}$

threshold can be set at 127 or 1023 locations from the full boundary. All these choices are made with  $\overline{LD}$  during Master Reset.

In the serial method,  $\overline{SEN}$  together with  $\overline{LD}$  are used to load the offset registers via the Serial Input (SI). In the parallel method,  $\overline{WEN}$  together with  $\overline{LD}$  can be used to load the offset registers via  $D_n$ .  $\overline{REN}$  together with  $\overline{LD}$  can be used to read the offsets in parallel from  $Q_n$  regardless of whether serial or parallel offset loading is selected.

During Master Reset ( $\overline{MRS}$ ), the read and write pointers are set to the first location of the FIFO. The FWFT line selects IDT Standard Mode or FWFT Mode. The  $\overline{LD}$  pin selects one of two partial flag default settings (127 or 1023) and, also, serial or parallel programming. The flags are updated accordingly.

The Partial Reset ( $\overline{PRS}$ ) also sets the read and write pointers to the first location of the memory. However, the mode setting, programming method, and partial flag offsets are not altered. The flags are updated accordingly.  $\overline{PRS}$  is useful for resetting a device in mid-operation, when repro-

## PIN CONFIGURATIONS

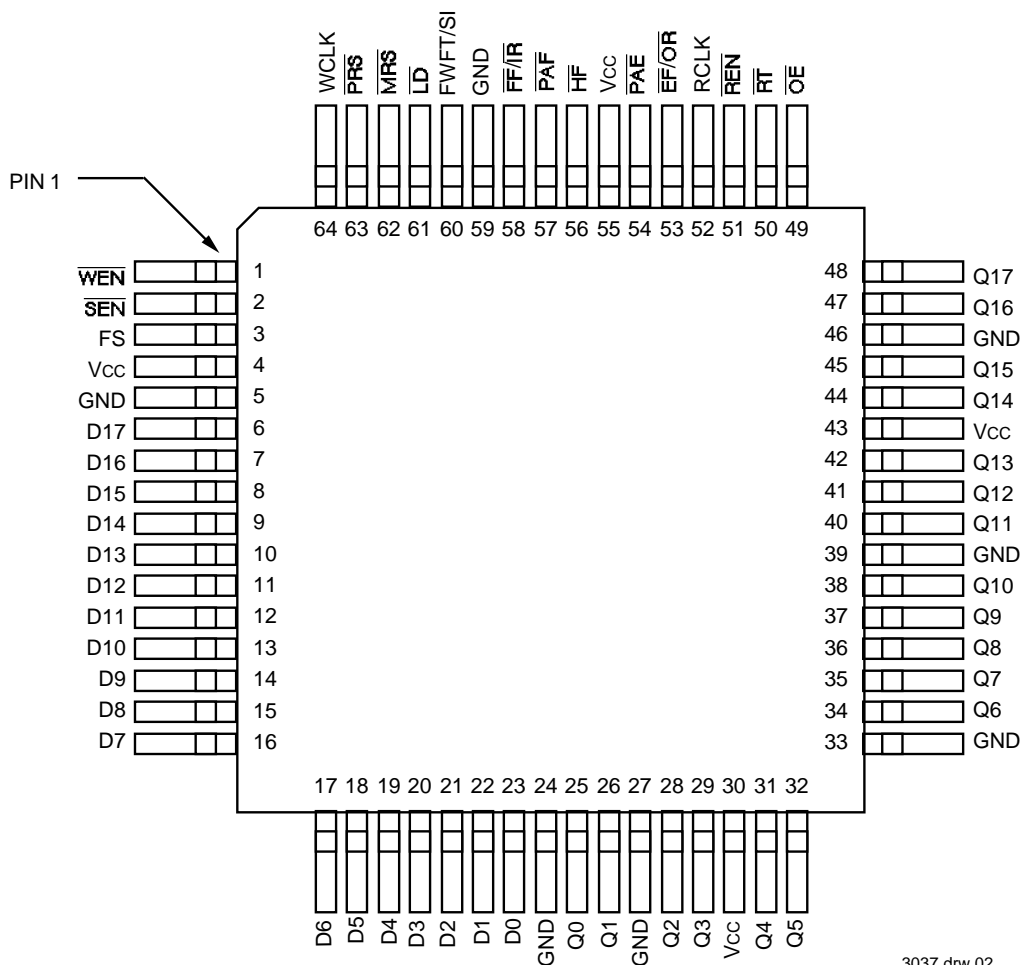

3037 drw 02

TQFP (PN64-1, order code: PF)  
STQFP (PP64-1, order code: TF)  
TOP VIEW

gramming offset registers may not be convenient.

The Retransmit function allows the read pointer to be reset to the first location in the RAM array. It is synchronized to RCLK when RT is LOW. This feature is convenient for sending the same data more than once.

If, at any time, the FIFO is not actively performing a function, the chip will automatically power down. This occurs if neither a read nor a write occurs within 10 cycles of the faster clock, RCLK or WCLK. During the Power Down state, supply current consumption (Icc2) is at a minimum. Initiating any operation (by activating control inputs) will immediately take the device

out of the Power Down state.

The IDT72255/72265 are depth expandable. The addition of external components is unnecessary. The IR and OR functions, together with REN and WEN, are used to extend the total FIFO memory capacity.

The FS line ensures optimal data flow through the FIFO. It is tied to GND if the RCLK frequency is higher than the WCLK frequency or to Vcc if the RCLK frequency is lower than the WCLK frequency

The IDT72255/72265 is fabricated using IDT's high speed submicron CMOS technology.

**PIN CONFIGURATIONS (CONT.)**

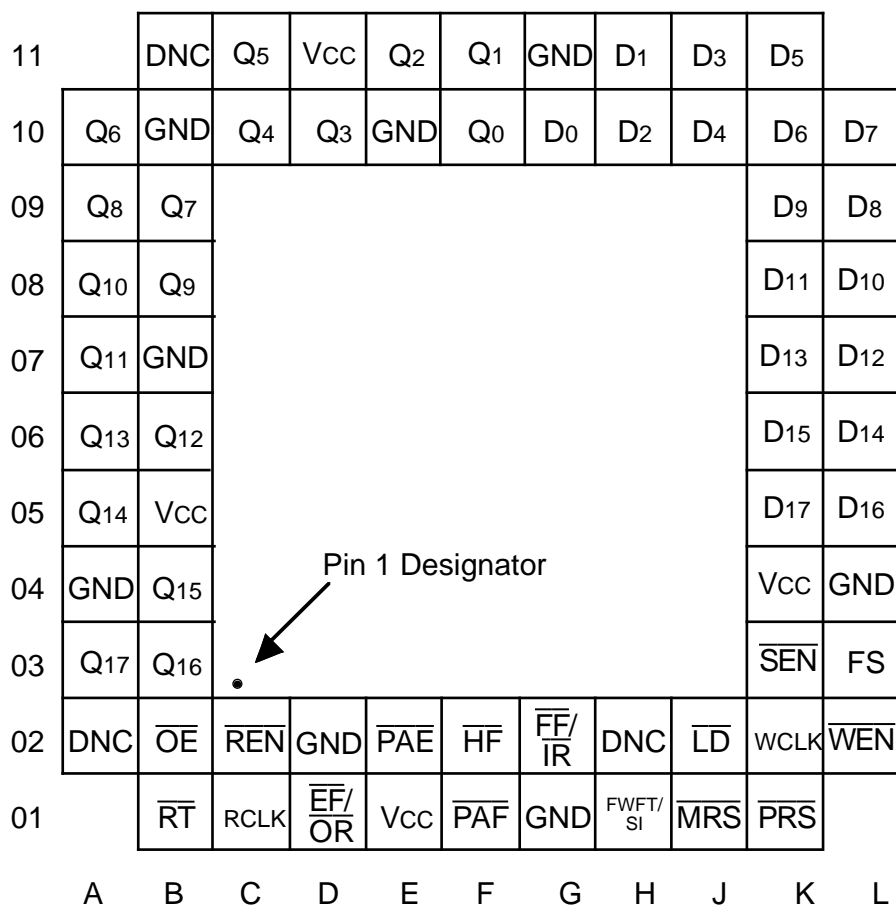

3037 drw 03

**PGA (G68-1, order code: G)  
TOP VIEW**

**NOTES:**

1. DNC = Do not connect

## PIN DESCRIPTION

Symbol	Name	I/O	Description
D0–D17	Data Inputs	I	Data inputs for a 18-bit bus.
$\overline{\text{MRS}}$	Master Reset	I	$\overline{\text{MRS}}$ initializes the read and write pointers to zero and sets the output register to all zeroes. During Master Reset, the FIFO is configured for either FWFT or IDT Standard Mode, one of two programmable flag default settings, and serial or parallel programming of the offset settings.
$\overline{\text{PRS}}$	Partial Reset	I	$\overline{\text{PRS}}$ initializes the read and write pointers to zero and sets the output register to all zeroes. During Partial Reset, the existing mode (IDT or FWFT), programming method (serial or parallel), and programmable flag settings are all retained.
$\overline{\text{RT}}$	Retransmit	I	Allows data to be resent starting with the first location of FIFO memory.
FWFT/SI	First Word Fall Through/Serial In	I	During Master Reset, selects First Word Fall Through or IDT Standard mode. After Master Reset, this pin functions as a serial input for loading offset registers
WCLK	Write Clock	I	When enabled by $\overline{\text{WEN}}$ , the rising edge of WCLK writes data into the FIFO and offsets into the programmable registers.
$\overline{\text{WEN}}$	Write Enable	I	$\overline{\text{WEN}}$ enables WCLK for writing data into the FIFO memory and offset registers.
RCLK	Read Clock	I	When enabled by $\overline{\text{REN}}$ , the rising edge of RCLK reads data from the FIFO memory and offsets from the programmable registers.
$\overline{\text{REN}}$	Read Enable	I	$\overline{\text{REN}}$ enables RCLK for reading data from the FIFO memory and offset registers.
$\overline{\text{OE}}$	Output Enable	I	$\overline{\text{OE}}$ controls the output impedance of $Q_n$
$\overline{\text{SEN}}$	Serial Enable	I	$\overline{\text{SEN}}$ enables serial loading of programmable flag offsets
$\overline{\text{LD}}$	Load	I	During Master Reset, $\overline{\text{LD}}$ selects one of two partial flag default offsets (127 and 1023) and determines programming method, serial or parallel. After Master Reset, this pin enables writing to and reading from the offset registers.
FS	Frequency Select	I	The FS setting optimizes data flow through the FIFO.
$\overline{\text{FF}}/\overline{\text{IR}}$	Full Flag/ Input Ready	O	In the IDT Standard Mode, the $\overline{\text{FF}}$ function is selected. $\overline{\text{FF}}$ indicates whether or not the FIFO memory is full. In the FWFT mode, the $\overline{\text{IR}}$ function is selected. $\overline{\text{IR}}$ indicates whether or not there is space available for writing to the FIFO memory.
$\overline{\text{EF}}/\overline{\text{OR}}$	Empty Flag/ Output Ready	O	In the IDT Standard Mode, the $\overline{\text{EF}}$ function is selected. $\overline{\text{EF}}$ indicates whether or not the FIFO memory is empty. In FWFT mode, the $\overline{\text{OR}}$ function is selected. $\overline{\text{OR}}$ indicates whether or not there is valid data available at the outputs.
$\overline{\text{PAF}}$	Programmable Almost Full Flag	O	$\overline{\text{PAF}}$ goes HIGH if the number of free locations in the FIFO memory is more than offset $m$ which is stored in the Full Offset register. $\overline{\text{PAF}}$ goes LOW if the number of free locations in the FIFO memory is less than $m$ .
$\overline{\text{PAE}}$	Programmable Almost Empty Flag	O	$\overline{\text{PAE}}$ goes LOW if the number of words in the FIFO memory is less than offset $n$ which is stored in the Empty Offset register. $\overline{\text{PAE}}$ goes HIGH if the number of words in the FIFO memory is greater than offset $n$ .
$\overline{\text{HF}}$	Half-full Flag	O	$\overline{\text{HF}}$ indicates whether the FIFO memory is more or less than half-full.
Q0–Q17	Data Outputs	O	Data outputs for a 18-bit bus.
VCC	Power		+5 volt power supply pins.
GND	Ground		Ground pins.

## ABSOLUTE MAXIMUM RATINGS<sup>(1)</sup>

Symbol	Rating	Commercial	Military	Unit
VTERM	Terminal Voltage with respect to GND	-0.5 to +7.0	-0.5 to +7.0	V
TA	Operating Temperature	0 to +70	-55 to +125	°C
TBIAS	Temperature Under Bias	-55 to +125	-65 to +135	°C
TSTG	Storage Temperature	-55 to +125	-65 to +155	°C
IOUT	DC Output Current	50	50	mA

**NOTE:**

3037 tbl 02

1. Stresses greater than those listed under ABSOLUTE MAXIMUM RATINGS may cause permanent damage to the device. This is a stress rating only and functional operation of the device at these or any other conditions above those indicated in the operational sections of this specification is not implied. Exposure to absolute maximum rating conditions for extended periods may affect reliability.

## RECOMMENDED DC OPERATING CONDITIONS

Symbol	Parameter	Min.	Typ.	Max.	Unit
VCCM	Military Supply Voltage	4.5	5.0	5.5	V
VCC	Commercial Supply Voltage	4.5	5.0	5.5	V
GND	Supply Voltage	0	0	0	V
V <sub>IH</sub>	Input High Voltage Commercial	2.0	—	—	V
V <sub>IH</sub>	Input High Voltage Military	2.2	—	—	V
V <sub>IL</sub> <sup>(1)</sup>	Input Low Voltage Commercial & Military	—	—	0.8	V

**NOTE:**

3037 tbl 03

1. 1.5V undershoots are allowed for 10ns once per cycle.

## DC ELECTRICAL CHARACTERISTICS

(Commercial: VCC = 5V ± 10%, TA = 0°C to +70°C; Military: VCC = 5V ± 10%, TA = -55°C to +125°C)

Symbol	Parameter	DT72255L IDT72265L Commercial tCLK = 10, 12, 15, 20ns			IDT72255L IDT72265L Military tCLK = 15, 25ns			Unit
		Min.	Typ.	Max.	Min.	Typ.	Max.	
I <sub>LI</sub> <sup>(1)</sup>	Input Leakage Current (any input)	-1	—	1	-10	—	10	μA
I <sub>LO</sub> <sup>(2)</sup>	Output Leakage Current	-10	—	10	-10	—	10	μA
V <sub>OH</sub>	Output Logic "1" Voltage, I <sub>OH</sub> = -2 mA	2.4	—	—	2.4	—	—	V
V <sub>OL</sub>	Output Logic "0" Voltage, I <sub>OL</sub> = 8 mA	—	—	0.4	—	—	0.4	V
I <sub>CC1</sub> <sup>(3)</sup>	Active Power Supply Current	—	—	180	—	—	250	mA
I <sub>CC2</sub> <sup>(3,4)</sup>	Power Down Current (All inputs = VCC - 0.2V or GND + 0.2V, RCLK and WCLK are free-running)	—	—	15	—	—	25	mA

**NOTES:**

3037 tbl 04

- Measurements with  $0.4 \leq V_{IN} \leq V_{CC}$ .
- $\overline{OE} = V_{IH}$
- Tested at  $f = 20$  MHz with outputs unloaded.
- No data written or read for more than 10 cycles

## CAPACITANCE (TA = +25°C, f = 1.0MHz)

Symbol	Parameter <sup>(1)</sup>	Conditions	Max.	Unit
C <sub>IN</sub> <sup>(2)</sup>	Input Capacitance	V <sub>IN</sub> = 0V	10	pF
C <sub>OUT</sub> <sup>(1,2)</sup>	Output Capacitance	V <sub>OUT</sub> = 0V	10	pF

**NOTES:**

3037 tbl 05

- With output deselected, ( $\overline{OE}$ =HIGH).
- Characterized values, not currently tested.

## AC ELECTRICAL CHARACTERISTICS<sup>(1)</sup>

(Commercial: VCC = 5V ± 10%, TA = 0°C to +70°C; Military: VCC = 5V ± 10%, TA = -55°C to +125°C)

Symbol	Parameter	Commercial				Com'l & Mil.		Commercial		Military		Unit
		72255L10 72265L10		72255L12 72265L12		72255L15 72265L15		72255L20 72265L20		72255L25 72265L25		
		Min.	Max.	Min.	Max.	Min.	Max.	Min.	Max.	Min.	Max.	
fs	Clock Cycle Frequency	—	100	—	83.3	—	66.7	—	50	—	40	MHz
tA	Data Access Time	2	8	2	9	2	10	2	12	3	15	ns
tCLK	Clock Cycle Time	10	—	12	—	15	—	20	—	25	—	ns
tCLKH	Clock High Time	4.5	—	5	—	6	—	8	—	10	—	ns
tCLKL	Clock Low Time	4.5 <sup>(2)</sup>	—	5 <sup>(2)</sup>	—	6 <sup>(2)</sup>	—	8	—	10	—	ns
tDS	Data Set-up Time	3.5	—	3.5	—	4	—	5	—	6	—	ns
tDH	Data Hold Time	0	—	0	—	1	—	1	—	1	—	ns
tENS	Enable Set-up Time	3.5	—	3.5	—	4	—	5	—	6	—	ns
tENH	Enable Hold Time	0	—	0	—	1	—	1	—	1	—	ns
tLDS	Load Set-up Time	3.5	—	3.5	—	4	—	5	—	6	—	ns
tLDH	Load Hold Time	6.5	—	8.5	—	10	—	10	—	10	—	ns
tRS	Reset Pulse Width <sup>(3)</sup>	10	—	12	—	15	—	20	—	25	—	ns
tRSS	Reset Set-up Time	10	—	12	—	15	—	20	—	25	—	ns
tRSR	Reset Recovery Time	10	—	12	—	15	—	20	—	25	—	ns
tRSF	Reset to Flag and Output Time	—	10	—	12	—	15	—	20	—	25	ns
tFWFT	Mode Select Time	0	—	0	—	0	—	0	—	0	—	ns
tRTS	Retransmit Set-Up Time	3.5	—	3.5	—	4	—	5	—	6	—	ns
tOLZ	Output Enable to Output in Low Z <sup>(4)</sup>	0	—	0	—	0	—	0	—	0	—	ns
tOE	Output Enable to Output Valid	3	7	3	7.5	3	8	3	10	3	13	ns
tOHZ	Output Enable to Output in High Z <sup>(4)</sup>	3	7	3	7.5	3	8	3	10	3	13	ns
tWFF	Write Clock to $\overline{FF}$ or $\overline{IR}$	—	8	—	9	—	10	—	12	—	15	ns
tREF	Read Clock to $\overline{EF}$ or $\overline{OR}$	—	8	—	9	—	10	—	12	—	15	ns
tPAF	Write Clock to PAF	—	8	—	9	—	10	—	12	—	15	ns
tPAE	Read Clock to PAE	—	8	—	9	—	10	—	12	—	15	ns
tHF	Clock to $\overline{HF}$	—	16	—	18	—	20	—	22	—	25	ns
tsKEW1	Skew time between RCLK and WCLK for $\overline{FF}$ and $\overline{IR}$	8	—	10	—	12	—	15	—	20	—	ns
tsKEW2	Skew time between RCLK and WCLK for PAE and PAF	15	—	18	—	21	—	25	—	35	—	ns

### NOTES:

- All AC timings apply to both Standard IDT Mode and First Word Fall Through Mode.
- For the RCLK line: tCLKL (min.) = 7 ns only when reading the offsets from the programmable flag registers; otherwise, use the table value. For the WCLK line, use the tCLKL (min.) value given in the table.
- Pulse widths less than minimum values are not allowed.
- Values guaranteed by design, not currently tested.

### AC TEST CONDITIONS

Input Pulse Levels	GND to 3.0V
Input Rise/Fall Times	3ns
Input Timing Reference Levels	1.5V
Output Reference Levels	1.5V
Output Load	See Figure 1

3037 tbl 08

3037 tbl 06

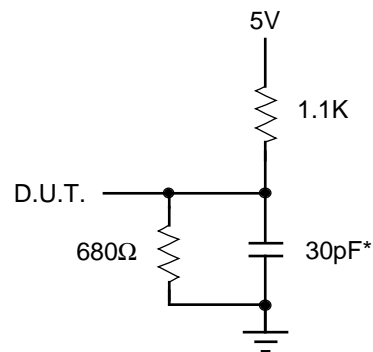

3037 drw 04

Figure 1. Output Load

\* Includes jig and scope capacitances.

## SIGNAL DESCRIPTIONS:

### INPUTS:

#### DATA IN (D<sub>0</sub> - D<sub>17</sub>)

Data inputs for 18-bit wide data.

### CONTROLS:

#### MASTER RESET ( $\overline{MRS}$ )

A Master Reset is accomplished whenever the Master Reset ( $\overline{MRS}$ ) input is taken to a LOW state. This operation sets the internal read and write pointers to the first location of the RAM array.  $\overline{PAE}$  will go LOW,  $\overline{PAF}$  will go HIGH, and  $\overline{HF}$  will go HIGH.

If FWFT is LOW during Master Reset then the IDT Standard Mode, along with  $\overline{EF}$  and  $\overline{FF}$  are selected.  $\overline{EF}$  will go LOW and  $\overline{FF}$  will go HIGH. If FWFT is HIGH, then the First Word Fall through Mode (FWFT), along with  $\overline{IR}$  and  $\overline{OR}$ , are selected.  $\overline{OR}$  will go HIGH and  $\overline{IR}$  will go LOW.

If  $\overline{LD}$  is LOW during Master Reset, then  $\overline{PAE}$  is assigned a threshold 127 words from the empty boundary and  $\overline{PAF}$  is assigned a threshold 127 words from the full boundary; 127 words corresponds to an offset value of 07FH. Following Master Reset, parallel loading of the offsets is permitted, but not serial loading.

If  $\overline{LD}$  is HIGH during Master Reset, then  $\overline{PAE}$  is assigned a threshold 1023 words from the empty boundary and  $\overline{PAF}$  is assigned a threshold 1023 words from the full boundary; 1023 words corresponds to an offset value of 3FFH. Following Master Reset, serial loading of the offsets is permitted, but not parallel loading.

Regardless of whether serial or parallel offset loading has been selected, parallel reading of the registers is always permitted. (See section describing the  $\overline{LD}$  line for further details).

During a Master Reset, the output register is initialized to all zeroes. A Master Reset is required after power up, before a write operation can take place.  $\overline{MRS}$  is asynchronous.

#### PARTIAL RESET ( $\overline{PRS}$ )

A Partial Reset is accomplished whenever the Partial Reset ( $\overline{PRS}$ ) input is taken to a LOW state. As in the case of the Master Reset, the internal read and write pointers are set to the first location of the RAM array,  $\overline{PAE}$  goes LOW,  $\overline{PAF}$  goes HIGH, and  $\overline{HF}$  goes HIGH.

Whichever mode is active at the time of partial reset, IDT Standard Mode or First Word Fall-through, that mode will remain selected. If the IDT Standard Mode is active, then  $\overline{FF}$  will go HIGH and  $\overline{EF}$  will go LOW. If the First word Fall-through Mode is active, then  $\overline{OR}$  will go HIGH, and  $\overline{IR}$  will go LOW.

Following Partial Reset, all values held in the offset registers remain unchanged. The programming method (parallel or serial) currently active at the time of Partial Reset is also retained. The output register is initialized to all zeroes.  $\overline{PRS}$  is asynchronous.

A Partial Reset is useful for resetting the device during the course of operation, when reprogramming flag settings may not be convenient.

#### RETRANSMIT ( $\overline{RT}$ )

The Retransmit operation allows data that has already been read to be accessed again. There are two stages: first, a setup procedure that resets the read pointer to the first location of memory, then the actual retransmit, which consists of reading out the memory contents, starting at the beginning of memory.

Retransmit Setup is initiated by holding  $\overline{RT}$  LOW during a rising RCLK edge.  $\overline{REN}$  and  $\overline{WEN}$  must be HIGH before bringing  $\overline{RT}$  LOW. At least one word, but no more than Full - 2 words should have been written into the FIFO between Reset (Master or Partial) and the time of Retransmit Setup (Full = 8,192 words for the 72255, 16,384 words for the 72265).

If IDT Standard mode is selected, the FIFO will mark the beginning of the Retransmit Setup by setting  $\overline{EF}$  LOW. The change in level will only be noticeable if  $\overline{EF}$  was HIGH before setup. During this period, the internal read pointer is initialized to the first location of the RAM array.

When  $\overline{EF}$  goes HIGH, Retransmit Setup is complete and read operations may begin starting with the first location in memory. Since IDT Standard Mode is selected, every word read including the first word following Retransmit Setup requires a LOW on  $\overline{REN}$  to enable the rising edge of RCLK. Writing operations can begin after one of two conditions have been met:  $\overline{EF}$  is HIGH or 14 cycles of the faster clock (RCLK or WCLK) have elapsed since the RCLK rising edge enabled by the  $\overline{RT}$  pulse.

The deassertion time of  $\overline{EF}$  during Retransmit Setup is variable. The parameter  $t_{RTF1}$ , which is measured from the rising RCLK edge enabled by  $\overline{RT}$  to the rising edge of  $\overline{EF}$  is described by the following equation:

$$t_{RTF1} \text{ max.} = 14 \cdot T_f + 3 \cdot T_{RCLK} \text{ (in ns)}$$

where  $T_f$  is either the RCLK or the WCLK period, whichever is shorter, and  $T_{RCLK}$  is the RCLK period.

Regarding  $\overline{FF}$ : Note that since no more than Full - 2 writes are allowed between a Reset and a Retransmit Setup,  $\overline{FF}$  will remain HIGH throughout the setup procedure.

For IDT Standard mode, updating the  $\overline{PAE}$ ,  $\overline{HF}$ , and  $\overline{PAF}$  flags begins with the "first"  $\overline{REN}$ -enabled rising RCLK edge following the end of Retransmit Setup (the point at which  $\overline{EF}$  goes HIGH). This same RCLK rising edge is used to access the "first" memory location.  $\overline{HF}$  is updated on the first RCLK rising edge.  $\overline{PAE}$  is updated after two more rising RCLK edges.  $\overline{PAF}$  is updated after the "first" rising RCLK edge, followed by the next two rising WCLK edges. (If the  $t_{skew2}$  specification is not met, add one more WCLK cycle.)

If FWFT mode is selected, the FIFO will mark the beginning of the Retransmit Setup by setting  $\overline{OR}$  HIGH. The change in level will only be noticeable if  $\overline{OR}$  was LOW before setup. During this period, the internal read pointer is set to the first location of the RAM array.

When  $\overline{OR}$  goes LOW, Retransmit Setup is complete; at the same time, the contents of the first location are automatically displayed on the outputs. Since FWFT Mode is selected, the first word appears on the outputs, no read request necessary. Reading all subsequent words requires a LOW on  $\overline{REN}$  to enable the rising edge of RCLK. Writing operations can begin after one of two conditions have been met:  $\overline{OR}$  is LOW or 14 cycles of the faster clock (RCLK or WCLK) have elapsed since the RCLK rising edge enabled by the  $\overline{RT}$  pulse.

The assertion time of  $\overline{OR}$  during Retransmit Setup is variable. The parameter  $t_{RTF2}$ , which is measured from the rising RCLK edge enabled by  $\overline{RT}$  to the falling edge of  $\overline{OR}$  is described by the following equation:

$$t_{RTF2} \text{ max.} = 14 \cdot T_f + 4 \cdot T_{RCLK} \text{ (in ns)}$$

where  $T_f$  is either the RCLK or the WCLK period, whichever is shorter, and  $T_{RCLK}$  is the RCLK period. Note that a Retransmit Setup in FWFT mode requires one more RCLK cycle than in IDT Standard mode.

Regarding  $\overline{IR}$ : Note that since no more than Full - 2 writes are allowed between a Reset and a Retransmit Setup,  $\overline{IR}$  will remain LOW throughout the setup procedure.

For FWFT mode, updating the  $\overline{PAE}$ ,  $\overline{HF}$ , and  $\overline{PAF}$  flags begins with the "last" rising edge of RCLK before the end of Retransmit Setup. This is the same edge that asserts  $\overline{OR}$  and automatically accesses the first memory location. Note that, in this case,  $\overline{REN}$  is not required to initiate flag updating.  $\overline{HF}$  is updated on the "last" RCLK rising edge.  $\overline{PAE}$  is updated after two more rising RCLK edges.  $\overline{PAF}$  is updated after the "last" rising RCLK edge, followed by the next two rising WCLK edges. (If the  $t_{skew2}$  specification is not met, add one more WCLK cycle.)

$\overline{RT}$  is synchronized to RCLK. The Retransmit operation is useful in the event of a transmission error on a network, since it allows a data packet to be resent.

#### FIRST WORD FALL THROUGH/SERIAL IN (FWFT/SI)

This is a dual purpose pin. During Master Reset, the state of the FWFT/SI helps determine whether the device will operate in IDT Standard mode or First Word Fall Through (FWFT) mode.

If, at the time of Master Reset, FWFT/SI is LOW, then IDT Standard mode will be selected. This mode uses the Empty Flag ( $\overline{EF}$ ) to indicate whether or not there are any words present in the FIFO memory. It also uses the Full Flag function ( $\overline{FF}$ ) to indicate whether or not the FIFO memory has any free space for writing. In IDT Standard mode, every word read from the FIFO, including the first, must be requested using the Read Enable ( $\overline{REN}$ ) line.

If, at the time of Master Reset, FWFT/SI is HIGH, then FWFT mode will be selected. This mode uses Output Ready ( $\overline{OR}$ ) to indicate whether or not there is valid data at the data outputs ( $Q_n$ ). It also uses Input Ready ( $\overline{IR}$ ) to indicate whether or not the FIFO memory has any free space for writing. In the FWFT mode, the first word written to an empty FIFO goes directly to  $Q_n$ , no read request necessary. Subsequent words must be accessed using the Read Enable ( $\overline{REN}$ ) line.

After Master Reset, FWFT/SI acts as a serial input for loading  $\overline{PAE}$  and  $\overline{PAF}$  offsets into the programmable registers. The serial input function can only be used when the serial loading method has been selected during Master Reset. FWFT/SI functions the same way in both IDT Standard and FWFT modes.

#### WRITE CLOCK (WCLK)

A write cycle is initiated on the rising edge of the write clock (WCLK). Data set-up and hold times must be met with respect to the LOW-to-HIGH transition of the WCLK. The write and read clocks can either be asynchronous or coincident.

#### WRITE ENABLE ( $\overline{WEN}$ )

When Write Enable ( $\overline{WEN}$ ) is LOW, data can be loaded into the input register on the rising edge of every WCLK cycle. Data is stored in the RAM array sequentially and independently of any on-going read operation.

When  $\overline{WEN}$  is HIGH, the input register holds the previous data and no new data is loaded into the FIFO.

To prevent data overflow in the IDT Standard Mode,  $\overline{FF}$  will go LOW, inhibiting further write operations. Upon the completion of a valid read cycle,  $\overline{FF}$  will go HIGH allowing a write to occur.  $\overline{WEN}$  is ignored when the FIFO is full.

To prevent data overflow in the FWFT mode,  $\overline{IR}$  will go HIGH, inhibiting further write operations. Upon the completion of a valid read cycle,  $\overline{IR}$  will go LOW allowing a write to occur.  $\overline{WEN}$  is ignored when the FIFO is full.

#### READ CLOCK (RCLK)

Data can be read on the outputs, on the rising edge of the read clock (RCLK), when Output Enable ( $\overline{OE}$ ) is set LOW. The write and read clocks can be asynchronous or coincident.

#### READ ENABLE ( $\overline{REN}$ )

When Read Enable ( $\overline{REN}$ ) is LOW, data is loaded from the RAM array into the output register on the rising edge of the RCLK.

When  $\overline{REN}$  is HIGH, the output register holds the previous data and no new data is loaded into the output register.

In the IDT Standard Mode, every word accessed at  $Q_n$ , including the first word written to an empty FIFO, must be requested using  $\overline{REN}$ . When all the data has been read from the FIFO, the Empty Flag ( $\overline{EF}$ ) will go LOW, inhibiting further read operations.  $\overline{REN}$  is ignored when the FIFO is empty. Once a write is performed,  $\overline{EF}$  will go HIGH after  $t_{FWL1} + t_{REF}$  and a read is permitted.

In the FWFT Mode, the first word written to an empty FIFO automatically goes to the outputs  $Q_n$ , no need for any read request. In order to access all other words, a read must be executed using  $\overline{REN}$ . When all the data has been read from the FIFO, Output Ready ( $\overline{OR}$ ) will go HIGH, inhibiting further read operations.  $\overline{REN}$  is ignored when the FIFO is empty. Once a write is performed,  $\overline{OR}$  will go LOW after  $t_{FWL2} + t_{REF}$ , when the first word appears at  $Q_n$ ; if a second word is written into the FIFO, then  $\overline{REN}$  can be used to read it out.



### SERIAL ENABLE ( $\overline{SEN}$ )

Serial Enable is ( $\overline{SEN}$ ) is an enable used only for serial programming of the offset registers. The serial programming method must be selected during Master Reset.  $\overline{SEN}$  is always used in conjunction with  $\overline{LD}$ . When these lines are both LOW, data at the SI input can be loaded into the input register one bit for each LOW-to-HIGH transition of WCLK.

When  $\overline{SEN}$  is HIGH, the programmable registers retains the previous settings and no offsets are loaded.

$\overline{SEN}$  functions the same way in both IDT Standard and FWFT modes.

### OUTPUT ENABLE ( $\overline{OE}$ )

When Output Enable ( $\overline{OE}$ ) is enabled (LOW), the parallel output buffers receive data from the output register. When  $\overline{OE}$  is HIGH, the output data bus ( $Q_n$ ) goes into a high impedance state.







### LOAD ( $\overline{LD}$ )

This is a dual purpose pin. During Master Reset, the state of the Load line ( $\overline{LD}$ ) determines one of two default values (127 or 1023) for the  $\overline{PAE}$  and  $\overline{PAF}$  flags, along with the method by which these flags can be programmed, parallel or serial. After

Master Reset,  $\overline{LD}$  enables write operations to and read operations from the registers. Only the offset loading method currently selected can be used to write to the registers. Aside from Master Reset, there is no other way change the loading method. Registers can be read only in parallel; this can be accomplished regardless of whether serial or the parallel loading has been selected.

Associated with each of the programmable flags,  $\overline{PAE}$  and  $\overline{PAF}$ , are registers which can either be written to or read from. Offset values contained in these registers determine how many words need to be in the FIFO memory to switch a partial flag. A LOW on  $\overline{LD}$  during Master Reset selects a default  $\overline{PAE}$  offset value of 07FH ( a threshold 127 words from the empty boundary), a default  $\overline{PAF}$  offset value of 07FH (a threshold 127 words from the full boundary), and parallel loading of other offset values. A HIGH on  $\overline{LD}$  during Master Reset selects a default  $\overline{PAE}$  offset value of 3FFH (a threshold 1023 words from the empty boundary), a default  $\overline{PAF}$  offset value of 3FFH (a threshold 1023 words form the full boundary), and serial loading of other offset values.

The act of writing offsets (in parallel or serial) employs a dedicated write offset register pointer. The act of reading offsets employs a dedicated read offset register pointer. The

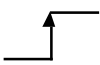
$\overline{LD}$	$\overline{WEN}$	$\overline{REN}$	$\overline{SEN}$	WCLK	RCLK	Selection
0	0	1	1		X	Parallel write to registers: Empty Offset  Full Offset
0	1	0	1	X		Parallel read from registers: Empty Offset  Full Offset
0	1	1	0		X	Serial shift into registers: 26 bits for the 72255 28 bits for the 72265 1 bit for each rising WCLK edge Starting with Empty Offset (LSB) Ending with Full Offset (MSB)
X	1	1	1	X	X	No Operation
1	0	X	X		X	Write Memory
1	X	0	X	X		Read Memory
1	1	1	X	X	X	No Operation

3037 tbl 02

#### NOTES:

1. Only one of the two offset programming methods, serial or parallel, is available for use at any given time.
2. The programming method can only be selected at Master Reset.
3. Parallel reading of the offset registers is always permitted regardless of which programming method has been selected.
4. The programming sequence applies to both IDT Standard and FWFT modes.

Figure 2. Partial Flag Programming Sequence

two pointers operate independently; however, a read and a write should not be performed simultaneously to the offset registers. A Master Reset initializes both pointers to the Empty Offset (LSB) register. A Partial Reset has no effect on the position of these pointers.

Once serial offset loading has been selected, then programming  $\overline{\text{PAE}}$  and  $\overline{\text{PAF}}$  proceeds as follows: When  $\overline{\text{LD}}$  and  $\overline{\text{SEN}}$  are set LOW, data on the SI input are written, one bit for each WCLK rising edge, starting with the Empty Offset (13 bits for the 72255, 14 bits for the 72265), ending with the Full Offset (13 bits for the 72255, 14 bits for the 72265). A total of 26 bits are necessary to program the 72255; a total of 28 bits are necessary to program the 72265. Individual registers cannot be loaded serially; rather, both must be programmed in sequence, no padding allowed.  $\overline{\text{PAE}}$  and  $\overline{\text{PAF}}$  can show a valid status only after the the full set of bits have been entered. The registers can be re-programmed, as long as both offsets are loaded. When  $\overline{\text{LD}}$  is LOW and  $\overline{\text{SEN}}$  is HIGH, no serial write to the registers can occur.

Once parallel offset loading has been selected, then programming  $\overline{\text{PAE}}$  and  $\overline{\text{PAF}}$  proceeds as follows: When  $\overline{\text{LD}}$  and  $\overline{\text{WEN}}$  are set LOW, data on the inputs  $D_n$  are written into the Empty Offset Register on the first LOW-to-HIGH transition of WCLK. Upon the second LOW-to-HIGH transition of WCLK, data at the inputs are written into the Full Register. The third transition of WCLK writes, once again, to the Empty Offset Register.

To ensure proper programming (serial or parallel) of the offset registers, no read operation is permitted from the time of reset (master or partial) to the time of programming. (During this period, the read pointer must be pointing to the first location of the memory array.) After the programming has been accomplished, read operations may begin.

Write operations to memory are allowed before and during the parallel programming sequence. In this case, the programming of all offset registers does not have to occur at one time. One or two offset registers can be written to and then, by bringing  $\overline{\text{LD}}$  HIGH, write operations can be redirected to the FIFO memory. When  $\overline{\text{LD}}$  is set LOW again, and  $\overline{\text{WEN}}$  is LOW, the next offset register in sequence is written to. As an alternative to holding  $\overline{\text{WEN}}$  LOW and toggling  $\overline{\text{LD}}$ , parallel programming can also be interrupted by setting  $\overline{\text{LD}}$  LOW and toggling  $\overline{\text{WEN}}$ .

Write operations to memory are allowed before and during the serial programming sequence. In this case, the programming of all offset bits does not have to occur at once. A select number of bits can be written to the SI input and then, by bringing  $\overline{\text{LD}}$  and  $\overline{\text{SEN}}$  HIGH, data can be written to FIFO memory via  $D_n$  by toggling  $\overline{\text{WEN}}$ . When  $\overline{\text{WEN}}$  is brought HIGH with  $\overline{\text{LD}}$  and  $\overline{\text{SEN}}$  restored to a LOW, the next offset bit in sequence is written to the registers via SI. If a mere interruption of serial programming is desired, it is sufficient either to set  $\overline{\text{LD}}$  LOW and deactivate  $\overline{\text{SEN}}$  or to set  $\overline{\text{SEN}}$  LOW and deactivate  $\overline{\text{LD}}$ . Once  $\overline{\text{LD}}$  and  $\overline{\text{SEN}}$  are both restored to a LOW level, serial offset programming continues from where it left off.

Note that the status of a partial flag ( $\overline{\text{PAE}}$  or  $\overline{\text{PAF}}$ ) output is invalid during the programming process. From the time parallel programming has begun, a partial flag output will not

be valid until the appropriate offset word has been written to the register pertaining to that flag. From the time serial programming has begun, neither partial flag will be valid until the full set of bits required to fill all the offset registers has been written. Measuring from the rising WCLK edge that achieves either of the above criteria;  $\overline{\text{PAF}}$  will be valid after two more rising WCLK edges plus  $t_{\text{PAF}}$ ,  $\overline{\text{PAE}}$  will be valid after the next two rising RCLK edges plus  $t_{\text{PAE}}$  (Add one more RCLK cycle if  $t_{\text{SKEW2}}$  is not met.)

The act of reading the offset registers employs a dedicated read offset register pointer. The contents of the offset registers can be read on the output lines when  $\overline{\text{LD}}$  is set LOW and  $\overline{\text{REN}}$  is set LOW; then, data are read via  $Q_n$  from the Empty Offset Register on the first LOW-to-HIGH transition of RCLK. Upon the second LOW-to-HIGH transition of RCLK, data are read from the Full Offset Register. The third transition of RCLK, reads, once again, from the Empty Offset Register.

It is permissible to interrupt the the offset register access sequence with reads or writes to memory. The interruption is accomplished by deasserting  $\overline{\text{REN}}$ ,  $\overline{\text{LD}}$ , or both together. When  $\overline{\text{REN}}$  and  $\overline{\text{LD}}$  are restored to a LOW level, access of the registers continues where it left off.

$\overline{\text{LD}}$  functions the same way in both IDT Standard and FWFT modes.

### FREQUENCY SELECT INPUT (FS)

An internal state machine manages the movement of data through the SuperSync FIFO. The FS line determines whether RCLK or WCLK will synchronize the state machine. Tie FS to Vcc if the RCLK line is running at a lower frequency than the WCLK line. In this case, the state machine will be synchronized to WCLK. Tie FS to GND if the RCLK line is running at a higher frequency than the WCLK line. In this case, the state machine will be synchronized to RCLK. Note that FS must be set so the clock line running at the higher frequency drives the state machine; this ensures efficient handling of the data within the FIFO. If the same clock signal drives both the WCLK and the RCLK pins, then tie FS to GND.

The frequency of the clock tied to the state machine (referred to as the "selected clock") may be changed at any time, so long as it is always greater than or equal to the frequency of the clock that is not tied to the state machine (referred to as the "non-selected clock"). The frequency of the non-selected clock can also be varied with time, so long as it never exceeds the frequency of the selected clock. To be more specific, the frequencies of both RCLK and WCLK may be varied during FIFO operation, provided that, at any given point in time, the cycle period of the selected clock is equal to or less than the cycle period of the non-selected clock.

The selected clock must be continuous. It is, however, permissible to stop the non-selected clock. Note, so long as RCLK is idle,  $\overline{\text{EF/OR}}$  and  $\overline{\text{PAE}}$  will not be updated. Likewise, as long as WCLK is idle,  $\overline{\text{FF/IR}}$  and  $\overline{\text{PAF}}$  will not be updated.

Changing the FS setting during FIFO operation (i.e. reading or writing) is not permitted; however, such a change at the time of Master Reset or Partial Reset is all right. FS is an asynchronous input.

**OUTPUTS:**

**FULL FLAG ( $\overline{FF}/\overline{IR}$ )**

This is a dual purpose pin. In IDT Standard Mode, the Full Flag (FF) function is selected. When the FIFO is full (i.e. the write pointer catches up to the read pointer), FF will go LOW, inhibiting further write operation. When FF is HIGH, the FIFO is not full. If no reads are performed after a reset (either MRS or PRS), FF will go LOW after 8,192 writes for the IDT72255 and 16,384 writes to the IDT72265.

In FWFT Mode, the Input Ready (IR) function is selected. IR goes LOW when memory space is available for writing in data. When there is no longer any free space left, IR goes HIGH, inhibiting further write operation. If no reads are performed after a reset (either MRS or PRS), IR will go HIGH after 8,193 writes for the IDT72255 and 16,385 writes for the IDT72265.

The IR status not only measures the contents of the FIFO memory, but also counts the presence of a word in the output register. Thus, in FWFT mode, the total number of writes necessary to deassert IR is one greater than needed to assert FF in IDT Standard mode.

FF/IR is synchronized to WCLK. It is double-registered to enhance metastable immunity.

**EMPTY FLAG ( $\overline{EF}/\overline{OR}$ )**

This is a dual purpose pin. In the IDT Standard Mode, the Empty Flag (EF) function is selected. When the FIFO is empty (i.e. the read pointer catches up to the write pointer), EF will go LOW, inhibiting further read operations. When EF is HIGH, the FIFO is not empty.

When writing the first word to an empty FIFO, the deassertion time of EF is variable, and can be represent by the First Word Latency parameter, tFWL1, which is measured from the rising WCLK edge that writes the first word to the rising RCLK edge

that updates the flag. tFWL1 includes any delays due to clock skew and can be expressed as follows:

$$tFWL1 \text{ max.} = 10 \cdot T_f + 2 \cdot TRCLK \text{ (in ns)}$$

where Tf is either the RCLK or the WCLK period, whichever is shorter, and TRCLK is the RCLK period. Since no read can take place until EF goes HIGH, the tFWL1 delay determines how early the first word can be available at Qn. This delay has no effect on the reading of subsequent words.

In FWFT Mode, the Output Ready (OR) function is selected. OR goes LOW at the same time that the first word written to an empty FIFO appears valid on the outputs. OR goes HIGH one cycle after RCLK shifts the last word from the FIFO memory to the outputs. Then further data reads are inhibited until OR goes LOW again.

When writing the first word to an empty FIFO, the assertion time of OR is variable, and can be represented by the First Word Latency parameter, tFWL2, which is measured from the rising WCLK edge that writes the first word to the rising RCLK edge that updates the flag. tFWL2 includes any delay due to clock skew and can be expressed as follows:

$$tFWL2 \text{ max.} = 10 \cdot T_f + 3 \cdot TRCLK \text{ (in ns)}$$

where Tf is either the RCLK or the WCLK period, whichever is shorter, and TRCLK is the RCLK period. Note that the First Word Latency in FWFT mode is one RCLK cycle longer than in IDT Standard mode. The tFWL2 delay determines how early the first word can be available at Qn. This delay has no effect on the reading of subsequent words.

EF/OR is synchronized to the RCLK. It is double-registered to enhance metastable immunity.

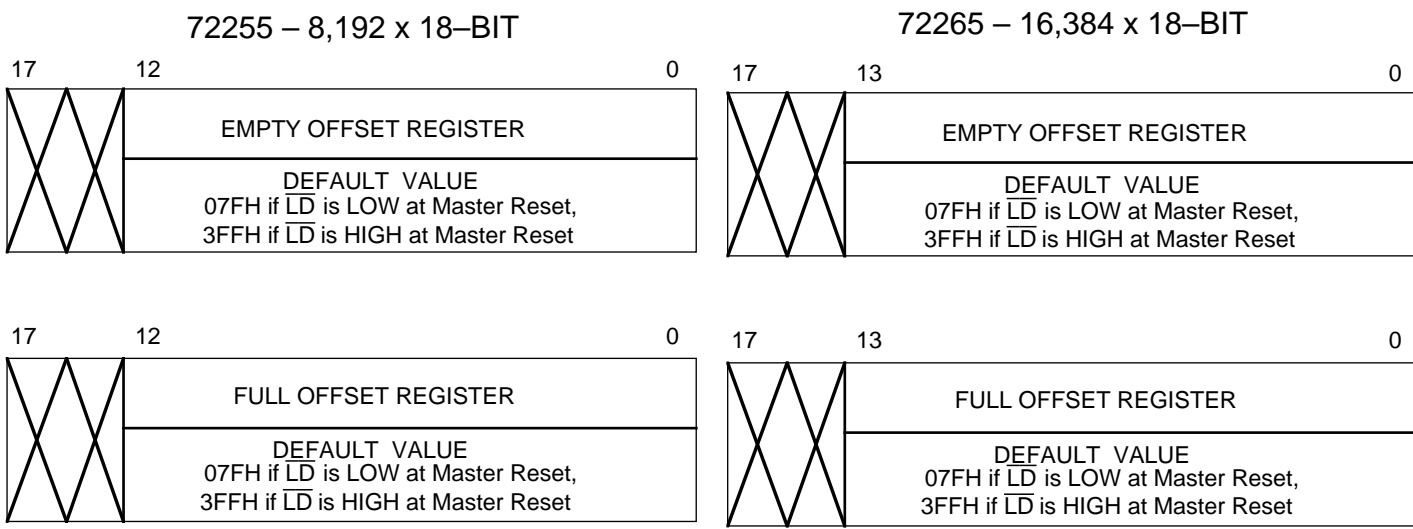

**NOTE:**

- Any bits of the offset register not being programmed should be set to zero.

Figure 3. Offset Register Location and Default Values

### PROGRAMMABLE ALMOST-FULL FLAG ( $\overline{\text{PAF}}$ )

The Programmable Almost-Full Flag ( $\overline{\text{PAF}}$ ) will go LOW when the FIFO reaches the Almost-Full condition as specified by the offset  $m$  stored in the Full Offset register.

At the time of Master Reset, depending on the state of  $\overline{\text{LD}}$ , one of two possible default offset values are chosen. If  $\overline{\text{LD}}$  is LOW, then  $m = 07\text{FH}$  and the  $\overline{\text{PAF}}$  switching threshold is 127 words from the Full boundary, if  $\overline{\text{LD}}$  is HIGH, then  $m = 3\text{FFH}$  and the  $\overline{\text{PAF}}$  switching threshold is 1023 words away from the Full boundary.

Any integral value of  $m$  from 0 to the maximum FIFO depth minus 1 (8,191 words for the 72255, 16,383 words for the 72265) can be programmed into the Full Offset register.

In IDT Standard Mode, if no reads are performed after reset ( $\overline{\text{MRS}}$  or  $\overline{\text{PRS}}$ ),  $\overline{\text{PAF}}$  will go LOW after (8,192- $m$ ) writes to the

IDT72255, and (16,384- $m$ ) writes to the IDT72265.

In FWFT Mode, if no reads are performed after reset ( $\overline{\text{MRS}}$  or  $\overline{\text{PRS}}$ ),  $\overline{\text{PAF}}$  will go LOW after (8,193- $m$ ) writes to the IDT72255, and (16,385- $m$ ) writes to the IDT72265. In this case, the first word written to an empty FIFO does not stay in memory, but goes unrequested to the output register; therefore, it has no effect on determining the state of  $\overline{\text{PAF}}$ .

Note that even though  $\overline{\text{PAF}}$  is programmed to switch LOW during the first word latency period ( $t_{\text{FWL}}$ ), attempts to read data will be ignored until  $\overline{\text{EF}}$  goes HIGH indicating that data is available at the output port. This is true for both timing modes.

$\overline{\text{PAF}}$  is synchronous and updated on the rising edge of  $\overline{\text{WCLK}}$ . It is double-registered to enhance metastable immunity.

**TABLE I — STATUS FLAGS FOR IDT STANDARD MODE**

Number of Words in FIFO Memory <sup>(1)</sup>		$\overline{\text{FF}}$	$\overline{\text{PAF}}$	$\overline{\text{HF}}$	$\overline{\text{PAE}}$	$\overline{\text{EF}}$
72255	72265					
0	0	H	H	H	L	L
1 to $n$ <sup>(2)</sup>	1 to $n$ <sup>(2)</sup>	H	H	H	L	H
( $n+1$ ) to 4,096	( $n+1$ ) to 8,192	H	H	H	H	H
4,097 to (8192-( $m+1$ ))	8,193 to (16,384-( $m+1$ ))	H	H	L	H	H
(8,192- $m$ ) <sup>(3)</sup> to 8,191	(16,384- $m$ ) <sup>(3)</sup> to 16,383	H	L	L	H	H
8,192	16,384	L	L	L	H	H

3037 tbl 03

**NOTES:**

1. Data in the output register does not count as a 'word in FIFO memory'. Since in FWFT mode, the first word written to an empty FIFO goes unrequested to the output register (no read operation necessary), it is not included in the FIFO memory count.
2.  $n$  = Empty Offset, Default Values:  $n = 127$  when parallel offset loading is selected or  $n=1023$  when serial offset loading is selected.
3.  $m$  = Full Offset, Default Values:  $m = 127$  when parallel offset loading is selected or  $n=1023$  when serial offset loading is selected.

**TABLE II — STATUS FLAGS FOR FWFT MODE**

Number of Words in FIFO Memory <sup>(1)</sup>		$\overline{\text{IR}}$	$\overline{\text{PAF}}$	$\overline{\text{HF}}$	$\overline{\text{PAE}}$	$\overline{\text{OR}}$
72255	72265					
0	0	L	H	H	L	H <sup>(4)</sup>
1 to $n$ <sup>(2)</sup>	1 to $n$ <sup>(2)</sup>	L	H	H	L	L
( $n+1$ ) to 4,096	( $n+1$ ) to 8,192	L	H	H	H	L
4,097 to (8192-( $m+1$ ))	8,193 to (16,384-( $m+1$ ))	L	H	L	H	L
(8,192- $m$ ) <sup>(3)</sup> to 8,191	(16,384- $m$ ) <sup>(3)</sup> to 16,383	L	L	L	H	L
8,192	16,384	H	L	L	H	L

3037 tbl 04

**NOTES:**

1. Data in the output register does not count as a 'word in FIFO memory'. Since in FWFT mode, the first word written to an empty FIFO goes unrequested to the output register (no read operation necessary), it is not included in the FIFO memory count.
2.  $n$  = Empty Offset, Default Values:  $n = 127$  when parallel offset loading is selected or  $n=1023$  when serial offset loading is selected.
3.  $m$  = Full Offset, Default Values:  $m = 127$  when parallel offset loading is selected or  $n=1023$  when serial offset loading is selected.
4. Following a reset (Master or Partial), the FIFO memory is empty and  $\overline{\text{OR}} = \text{HIGH}$ . After writing the first word, the FIFO memory remains empty, the data is placed into the output register, and  $\overline{\text{OR}}$  goes LOW. In this case, or any time the last word in the FIFO memory has been read into the output register; a rising RCLK edge, enabled by  $\overline{\text{REN}}$ , will set  $\overline{\text{OR}}$  HIGH.

### PROGRAMMABLE ALMOST-EMPTY FLAG ( $\overline{\text{PAE}}$ )

The Programmable Almost-Empty Flag ( $\overline{\text{PAE}}$ ) will go LOW when the FIFO reaches the Almost-Empty condition as specified by the offset  $n$  stored in the Empty Offset register.

At the time of Master Reset, depending on the state of  $\overline{\text{LD}}$ , one of two possible default offset values are chosen. If  $\overline{\text{LD}}$  is LOW, then  $n = 07\text{FH}$  and the  $\overline{\text{PAE}}$  switching threshold is 127 words from the Empty boundary, if  $\overline{\text{LD}}$  is HIGH, then  $n = 3\text{FFH}$  and the  $\overline{\text{PAE}}$  switching threshold is 1023 words away from the Empty boundary.

Any integral value of  $n$  from 0 to the maximum FIFO depth minus 1 (8,191 words for the 72255, 16,383 words for the 72265) can be programmed into the Empty Offset register.

In IDT Standard Mode, if no reads are performed after reset ( $\overline{\text{MRS}}$  or  $\overline{\text{PRS}}$ ), the  $\overline{\text{PAE}}$  will go HIGH after  $(n + 1)$  writes to the IDT72255/72265.

In FWFT Mode, if no reads are performed after reset ( $\overline{\text{MRS}}$  or  $\overline{\text{PRS}}$ ), the  $\overline{\text{PAE}}$  will go HIGH after  $(n+2)$  writes to the IDT72255/72265. In this case, the first word written to an empty FIFO does not stay in memory, but goes unrequested to the output register; therefore, it has no effect on determining the state of  $\overline{\text{PAE}}$ .

Note that even though  $\overline{\text{PAE}}$  is programmed to switch HIGH during the first word latency period ( $t_{\text{FWL}}$ ), attempts to read data will be ignored until  $\overline{\text{EF}}$  goes HIGH indicating that data is available at the output port. This is true for both timing modes.

$\overline{\text{PAE}}$  is synchronous and updated on the rising edge of RCLK. It is double-registered to enhance metastable immunity.

### HALF-FULL FLAG ( $\overline{\text{HF}}$ )

This output indicates a half-full memory. The rising WCLK edge that fills the memory beyond half-full sets  $\overline{\text{HF}}$  LOW. The flag remains LOW until the difference between the write and read pointers becomes less than or equal to half of the total depth of the device; the rising RCLK edge that accomplishes this condition also sets  $\overline{\text{HF}}$  HIGH.

In IDT Standard Mode, if no reads are performed after reset ( $\overline{\text{MRS}}$  or  $\overline{\text{PRS}}$ ),  $\overline{\text{HF}}$  will go LOW after  $(D/2 + 1)$  writes, where  $D$  is the maximum FIFO depth (8,192 words for the IDT72255, 16,384 words for the IDT72265).

In FWFT Mode, if no reads are performed after reset ( $\overline{\text{MRS}}$  or  $\overline{\text{PRS}}$ ),  $\overline{\text{HF}}$  will go LOW after  $(D/2+2)$  writes to the IDT72255/72265. In this case, the first word written to an empty FIFO does not stay in memory, but goes unrequested to the output register; therefore, it has no effect on determining the state of  $\overline{\text{HF}}$ .

Because  $\overline{\text{HF}}$  uses both RCLK and WCLK for synchronization purposes, it is asynchronous.

### DATA OUTPUTS (Q0-Q17)

Q0-Q17 are data outputs for 18-bit wide data.

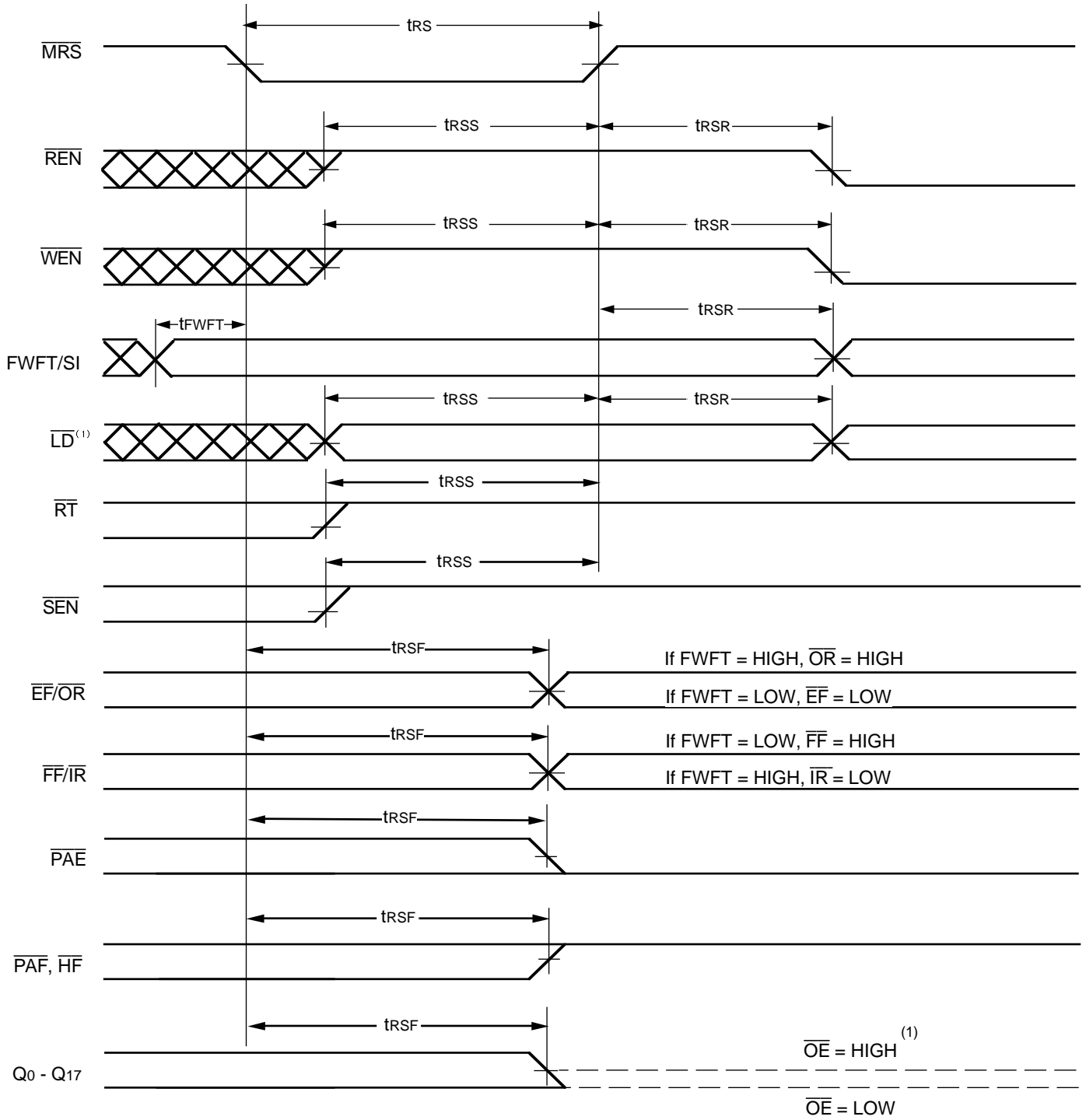

3037 drw 07

Figure 4. Master Reset Timing

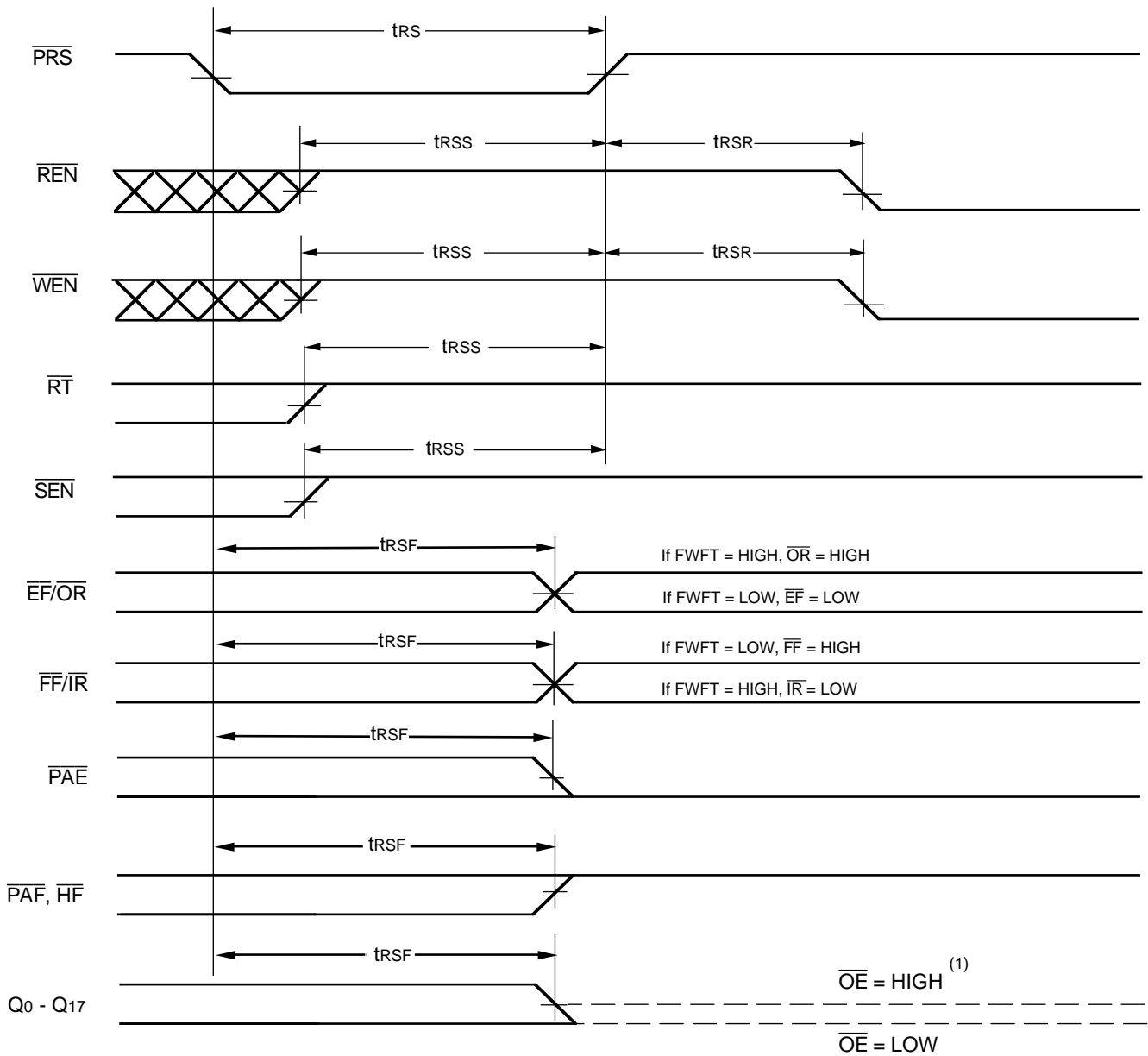

3037 drw 08

Figure 5. Partial Reset Timing

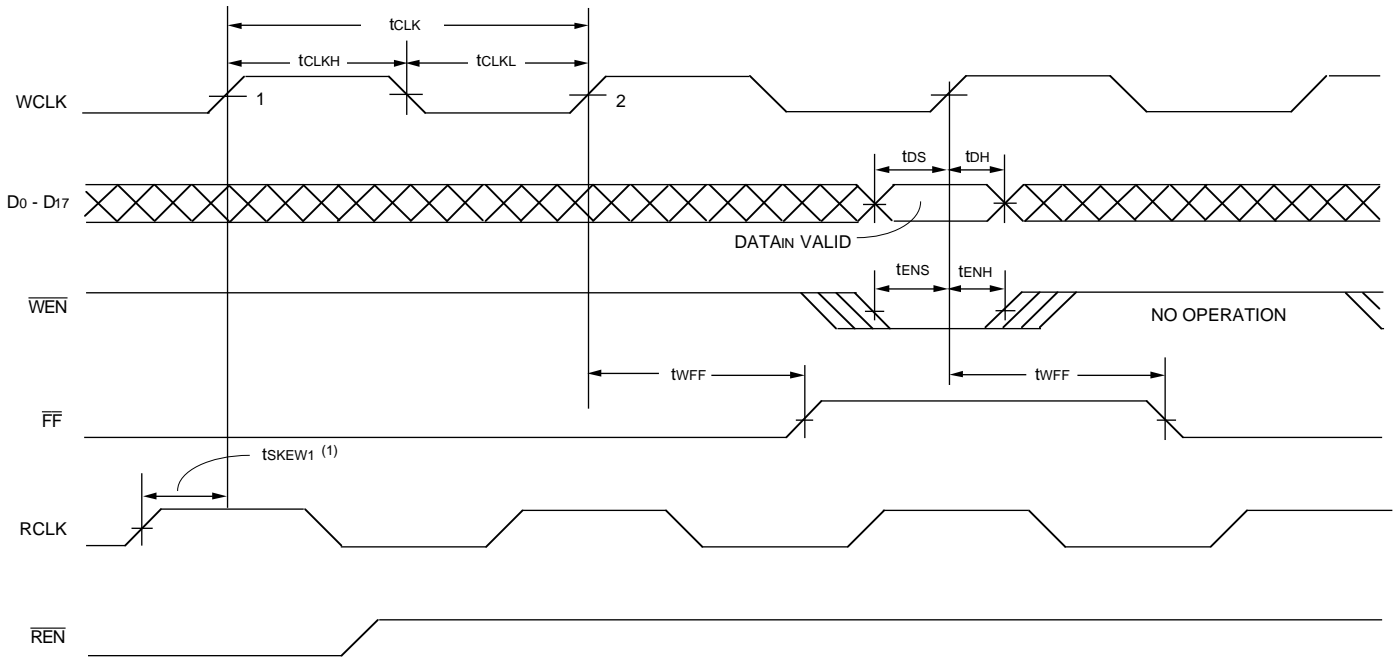

3037 drw 09

**NOTES:**

1.  $t_{SKEW1}$  is the minimum time between a rising RCLK edge and a rising WCLK edge to guarantee that  $\overline{FF}$  will go HIGH (after one WCLK cycle plus  $t_{WFF}$ ). If the time between the rising edge of RCLK and the rising edge of WCLK is less than  $t_{SKEW1}$ , then the  $\overline{FF}$  deassertion may be delayed an extra WCLK cycle.
2.  $\overline{LD} = \text{HIGH}$

**Figure 6. Write Cycle Timing (IDT Standard Mode)**



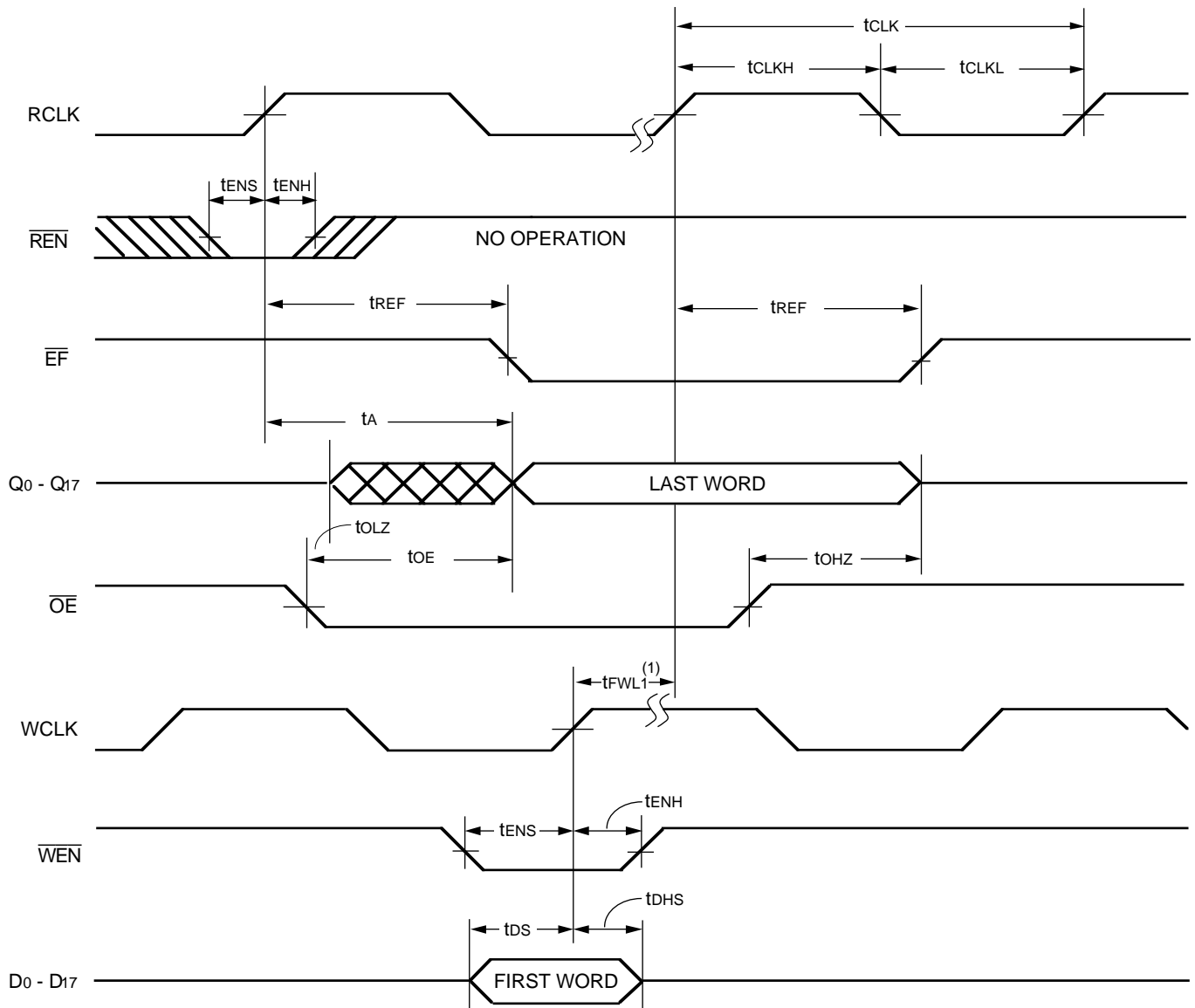

3037 drw 10

**NOTES:**

- $t_{FWL1}$  contributes a variable delay to the overall first word latency (this parameter includes delays due to skew):  
 $t_{FWL1 \text{ max. (in ns)}} = 10 \cdot T_f + 2 \cdot T_{RCLK}$   
 where  $T_f$  is either the RCLK or the WCLK period, whichever is shorter, and  $T_{RCLK}$  is the RCLK period
- LD = HIGH

Figure 7. Read Cycle Timing (IDT Standard Mode)

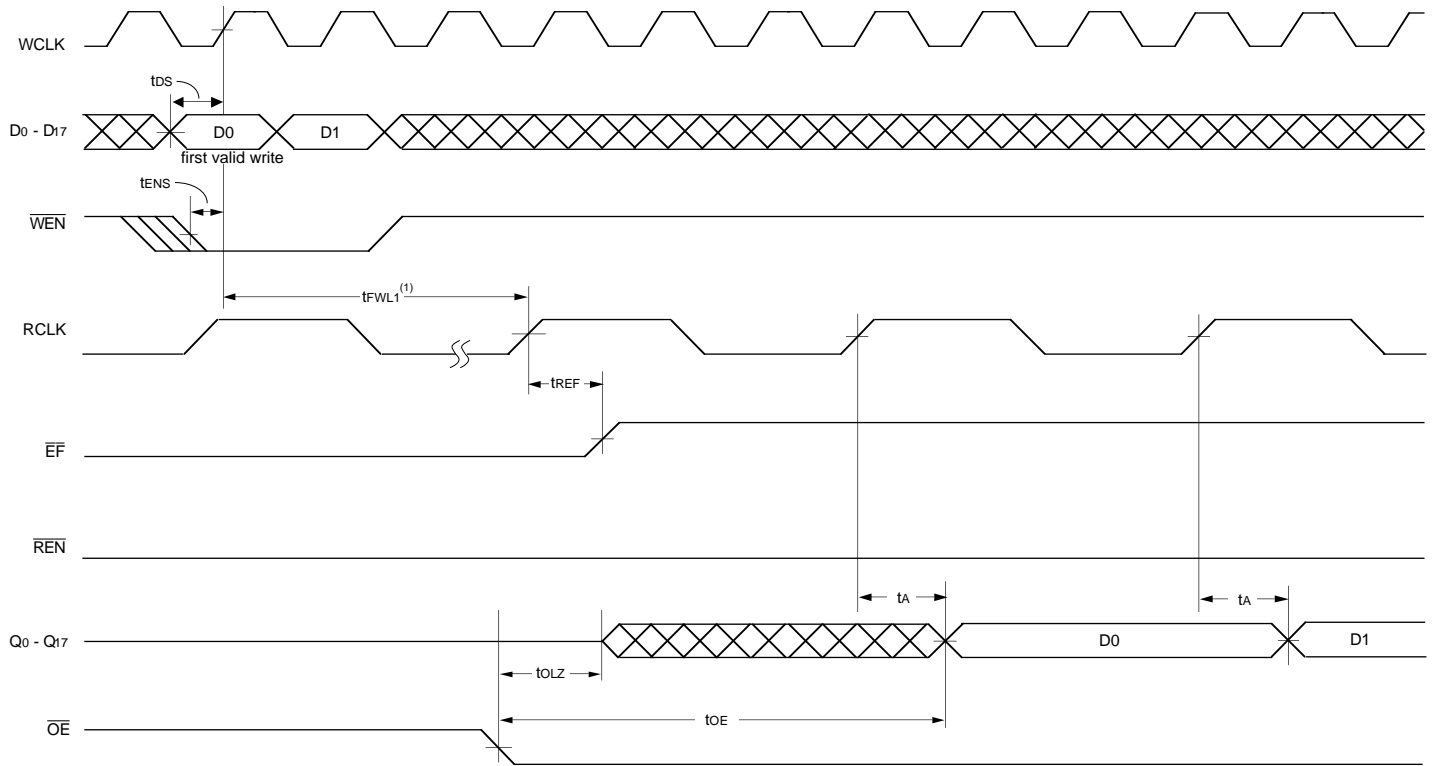

3037 drw 11

**NOTES:**

1.  $t_{FWL1} \text{ max. (in ns) } = 10 \cdot T_f + 2 \cdot T_{RCLK}$   
Where  $T_f$  is either the RCLK or the WCLK period, whichever is shorter, and  $T_{RCLK}$  is the RCLK period
2.  $\overline{LD} = \text{HIGH}$

**Figure 8. First Data Word Latency (IDT Standard Mode)**

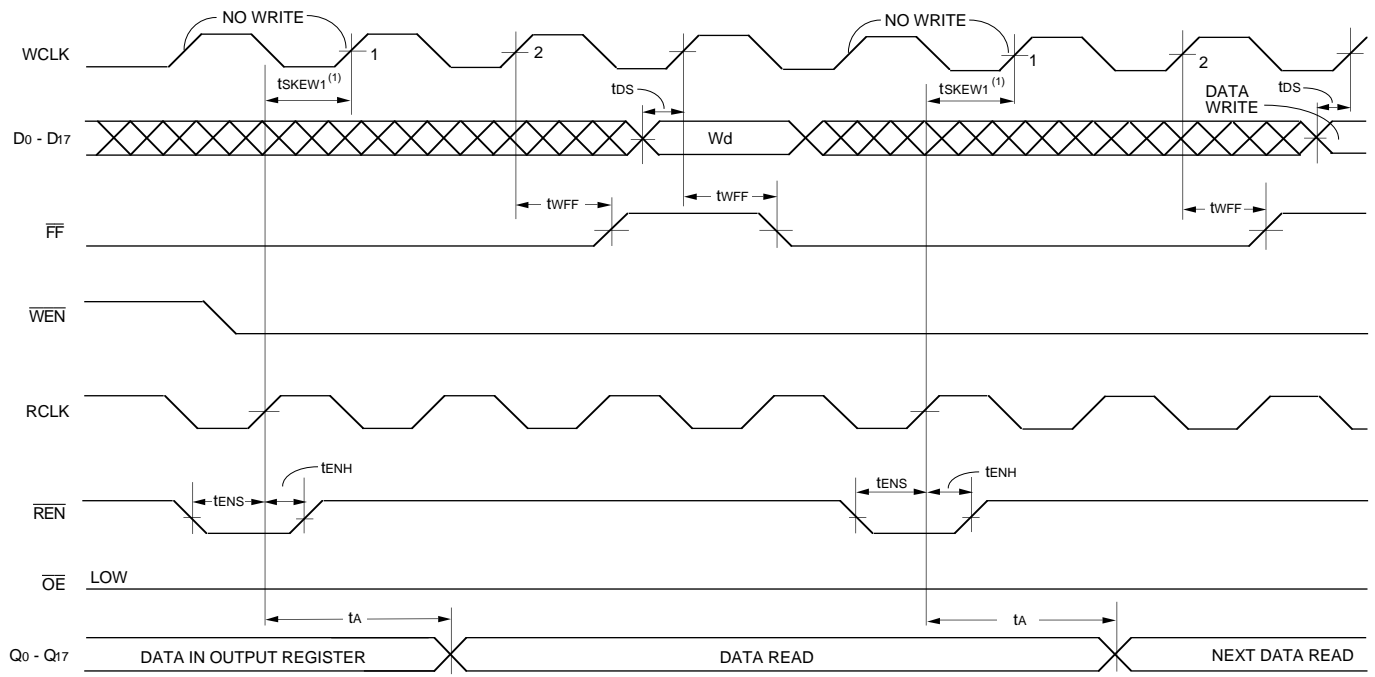

3037 drw 12

**NOTES:**

1.  $t_{SKEW1}$  is the minimum time between a rising RCLK edge and a rising WCLK edge to guarantee that  $\overline{FF}$  will go high (after one WCLK cycle plus  $t_{WFF}$ ). If the time between the rising edge of the RCLK and the rising edge of the WCLK is less than  $t_{SKEW1}$ , then the  $\overline{FF}$  deassertion may be delayed an extra WCLK cycle.
2.  $\overline{LD} = \text{HIGH}$

**Figure 9. Full Flag Timing (IDT Standard Mode)**

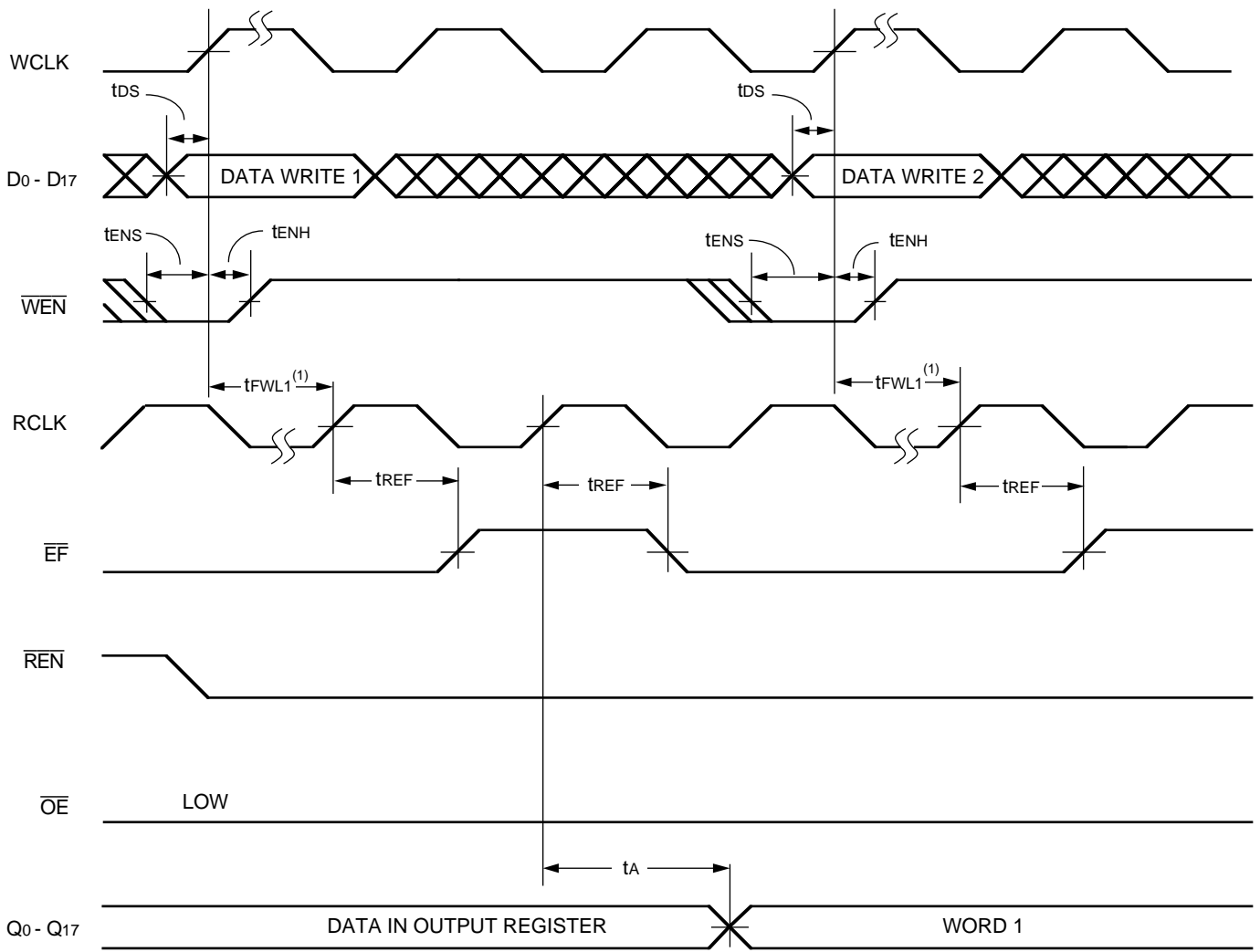

3037 drw 13

**NOTES:**

1.  $t_{FWL1} \text{ max. (in ns) } = 10 \cdot T_f + 2 \cdot T_{RCLK}$   
Where  $T_f$  is either the RCLK or the WCLK period, whichever is shorter, and  $T_{RCLK}$  is the period.
2. LD = HIGH

**Figure 10. Empty Flag Timing (IDT Standard Mode)**

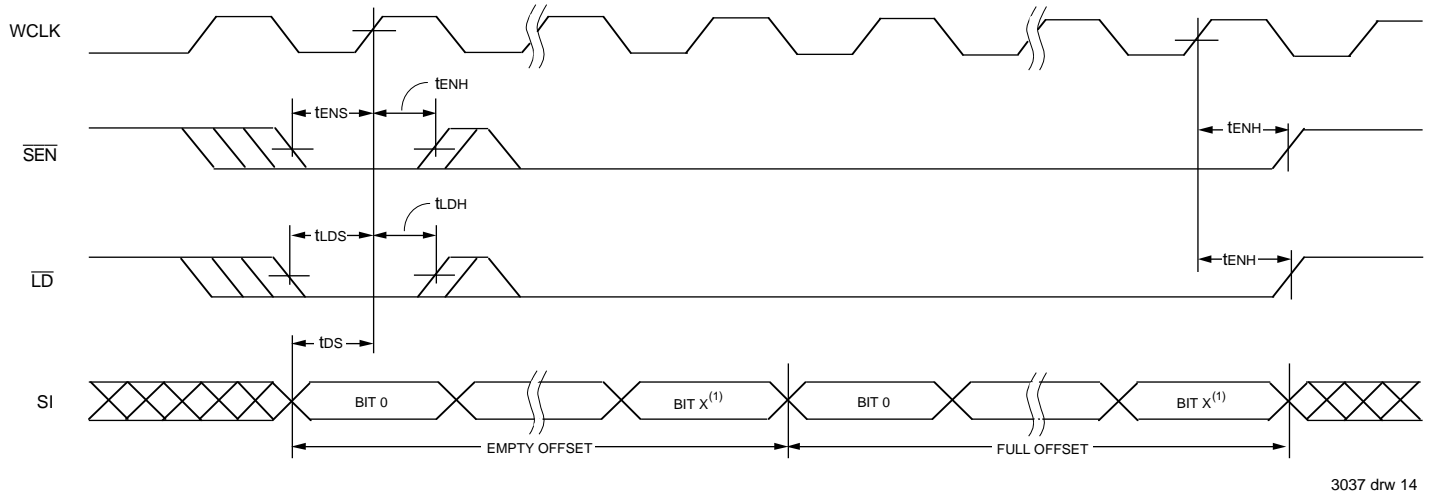

3037 drw 14

Figure 11. Serial Loading of Programmable Flag Registers (IDT Standard and FWFT modes)

**NOTE:**

1. For the 72255, X = 12.  
For the 72265, X = 13.

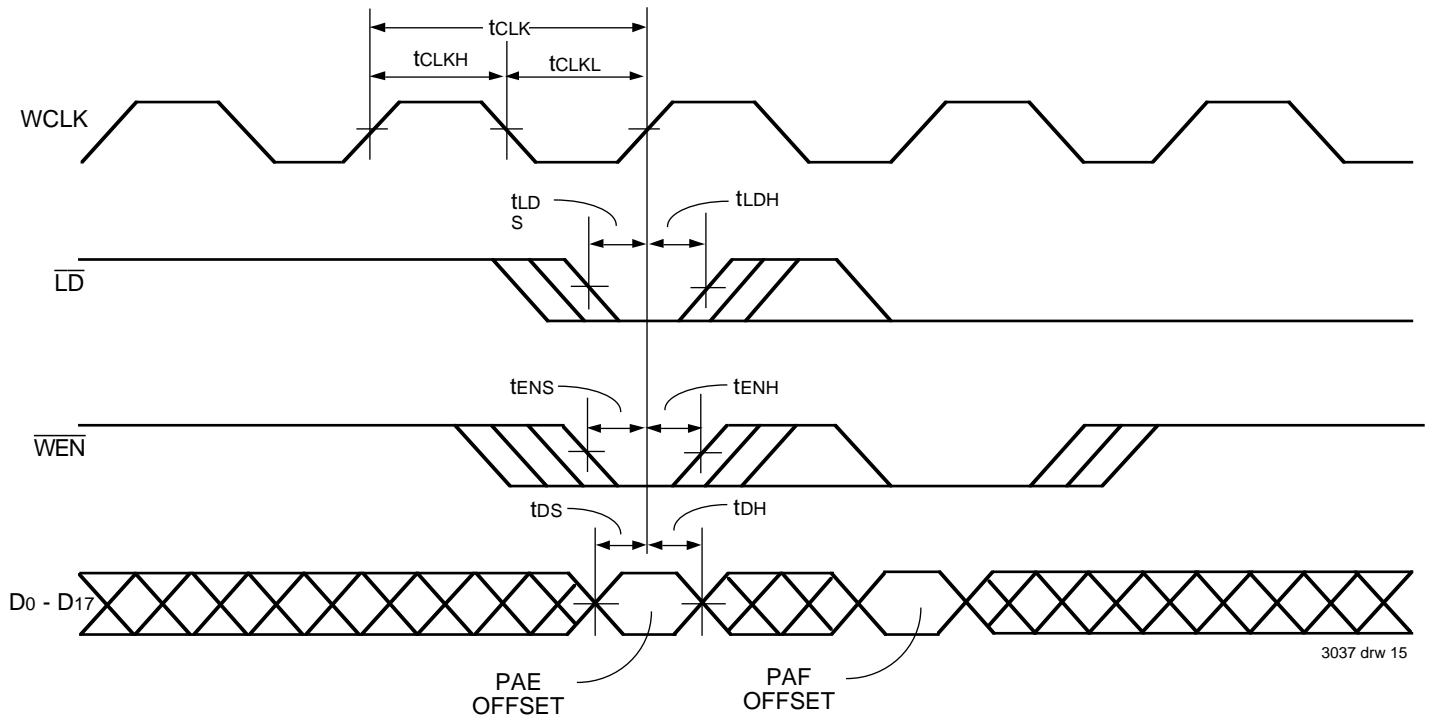

3037 drw 15

Figure 12. Parallel Loading of Programmable Flag Registers (IDT Standard and FWFT modes)

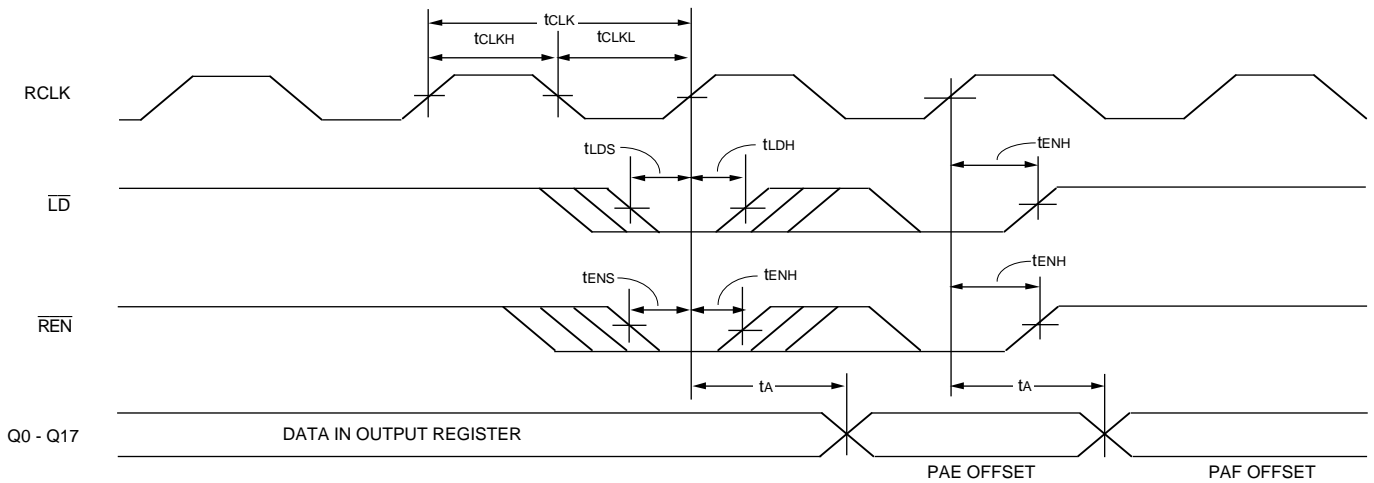

3037 drw 16

Figure 13. Parallel Read of Programmable Flag Registers (IDT Standard and FWFT modes)

**NOTE:**  
1.  $\overline{OE}$ =LOW

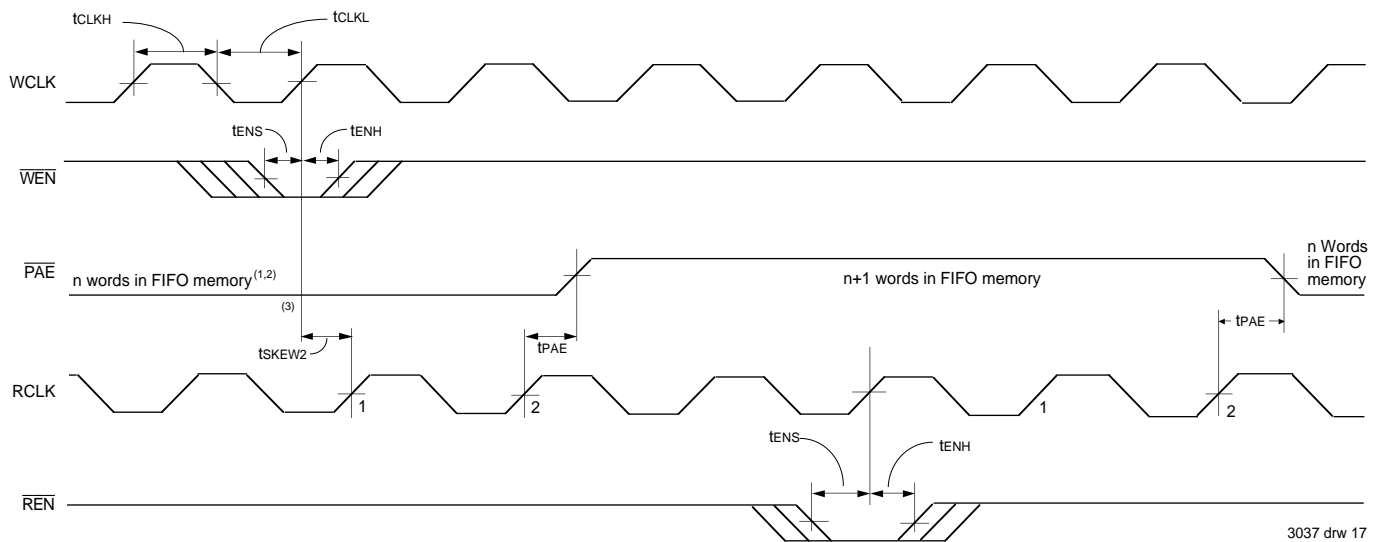

3037 drw 17

**NOTES:**

1. PAE offset = n
2. Data in the output register does not count as a "word in FIFO memory". Since, in FWFT mode, the first word written to an empty FIFO goes unrequested to the output register (no read operation necessary), it is not included in the FIFO memory count.
3. tsKEW2 is the minimum time between a rising WCLK edge and a rising RCLK edge for  $\overline{PAE}$  to go HIGH (after one RCLK cycle plus tPAE). If the time between the rising edge of WCLK and the rising edge of RCLK is less than tsKEW2, then the  $\overline{PAE}$  deassertion may be delayed one extra RCLK cycle.

Figure 14. Programmable Almost Empty Flag Timing (IDT Standard and FWFT modes)

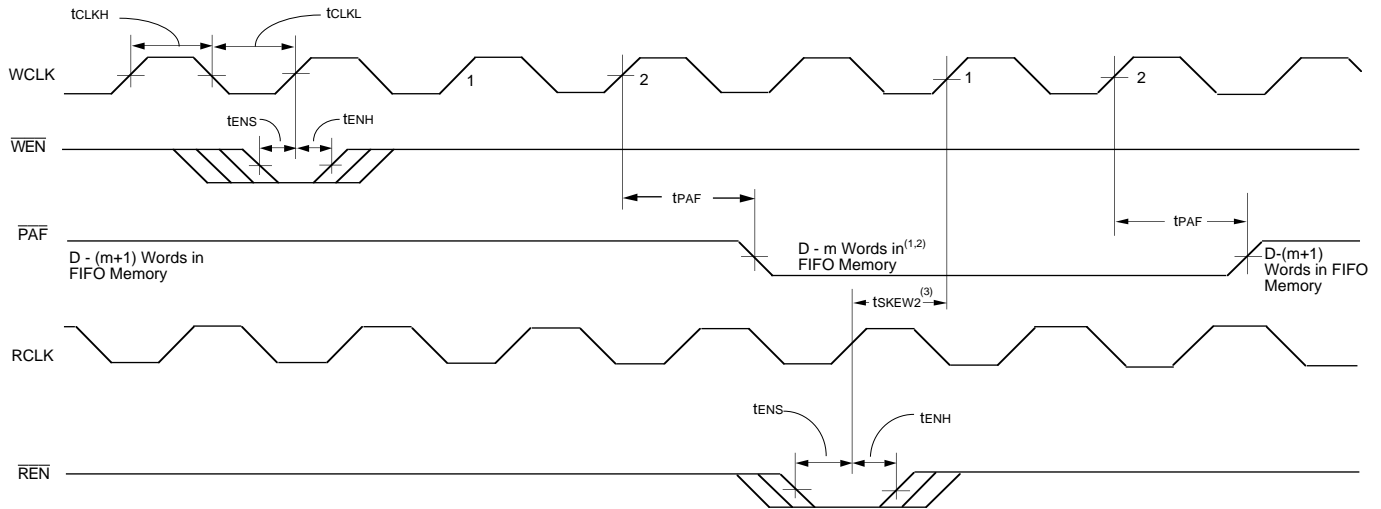

3037 drw 18

**NOTES:**

1. PAF offset = m, D = 8,192 for IDT 72255, 16,384 word for IDT 72265.
2. Data in the output register does not count as a "word in FIFO memory". Since, in FWFT mode, the first word written to an empty FIFO goes unrequested to the output register (no read operation necessary), it is not included in the FIFO memory count.
3. tsKEW2 is the minimum time between a rising RCLK edge and a rising WCLK edge for PAF to go HIGH (after one WCLK cycle plus tPAF). If the time between the rising edge of RCLK and the rising edge of WCLK is less than tsKEW2, then the PAF deassertion time may be delayed an extra WCLK cycle.

**Figure 15. Programmable Almost Full Flag Timing (IDT Standard and FWFT modes)**

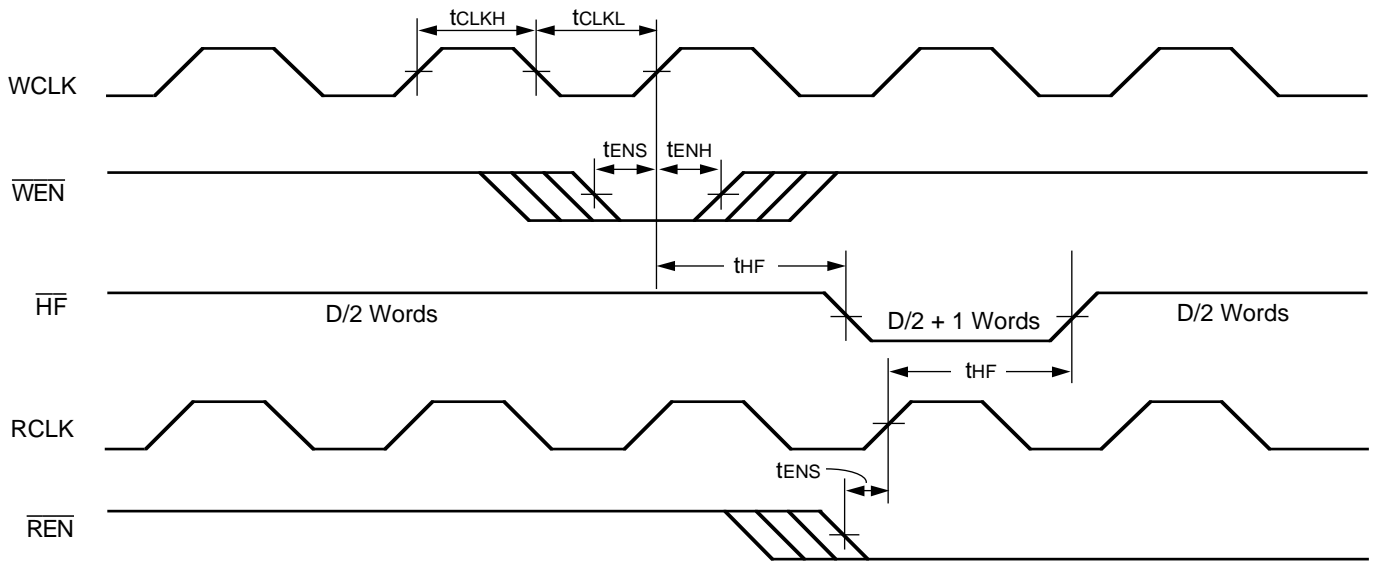

3037 drw 19

**NOTE:**

1. D = maximum FIFO depth = 8,192 for IDT 72255, 16,384 word for IDT 72265.

**Figure 16. Half - Full Flag Timing (IDT Standard and FWFT modes)**

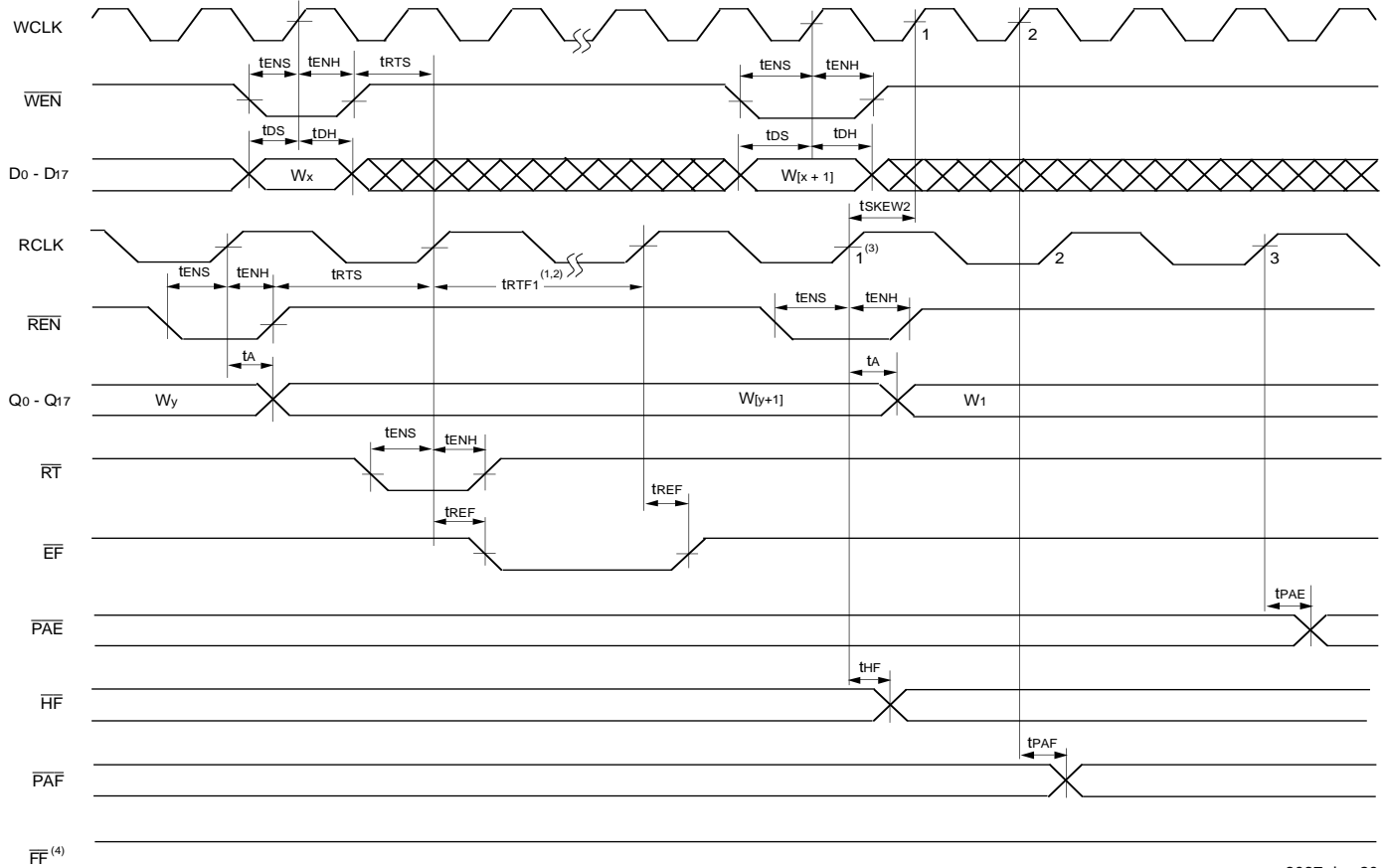

3037 drw 20

**NOTES:**

1.  $t_{RTF1}$  contributes a variable delay to the overall retransmit recovery time:  
 $t_{RTF1} \text{ max} = 14 \cdot T_f + 3 \cdot T_{RCLK}$  (in ns)  
 Where  $T_f$  is either the RCLK or the WCLK period, whichever is shorter, and  $T_{RCLK}$  is the RCLK period.
2. Retransmit set up is complete after  $\overline{EF}$  returns HIGH, only then can a read operation begin. Write operations are permitted after one of two conditions have been met:  $\overline{EF}$  is HIGH or 14 cycles of the faster clock (RCLK or WCLK) have elapsed since the RCLK rising edge enabled by the  $\overline{RT}$  pulse.
3. Following Retransmit Setup, the rising edge of RCLK that accesses the first memory location also initiates the updating of  $\overline{HF}$ ,  $\overline{PAE}$ , and  $\overline{PAF}$ .
4. No more than D-2 words (D = 8,192 words for the 72255, 16,384 words for the 72265) should have been written to the FIFO between Reset (Master or Partial) and Retransmit Setup. Therefore,  $\overline{FF}$  will be HIGH throughout the Retransmit Setup procedure.
5.  $\overline{OE} = \text{LOW}$

**Figure 17. Retransmit Timing (IDT Standard mode)**





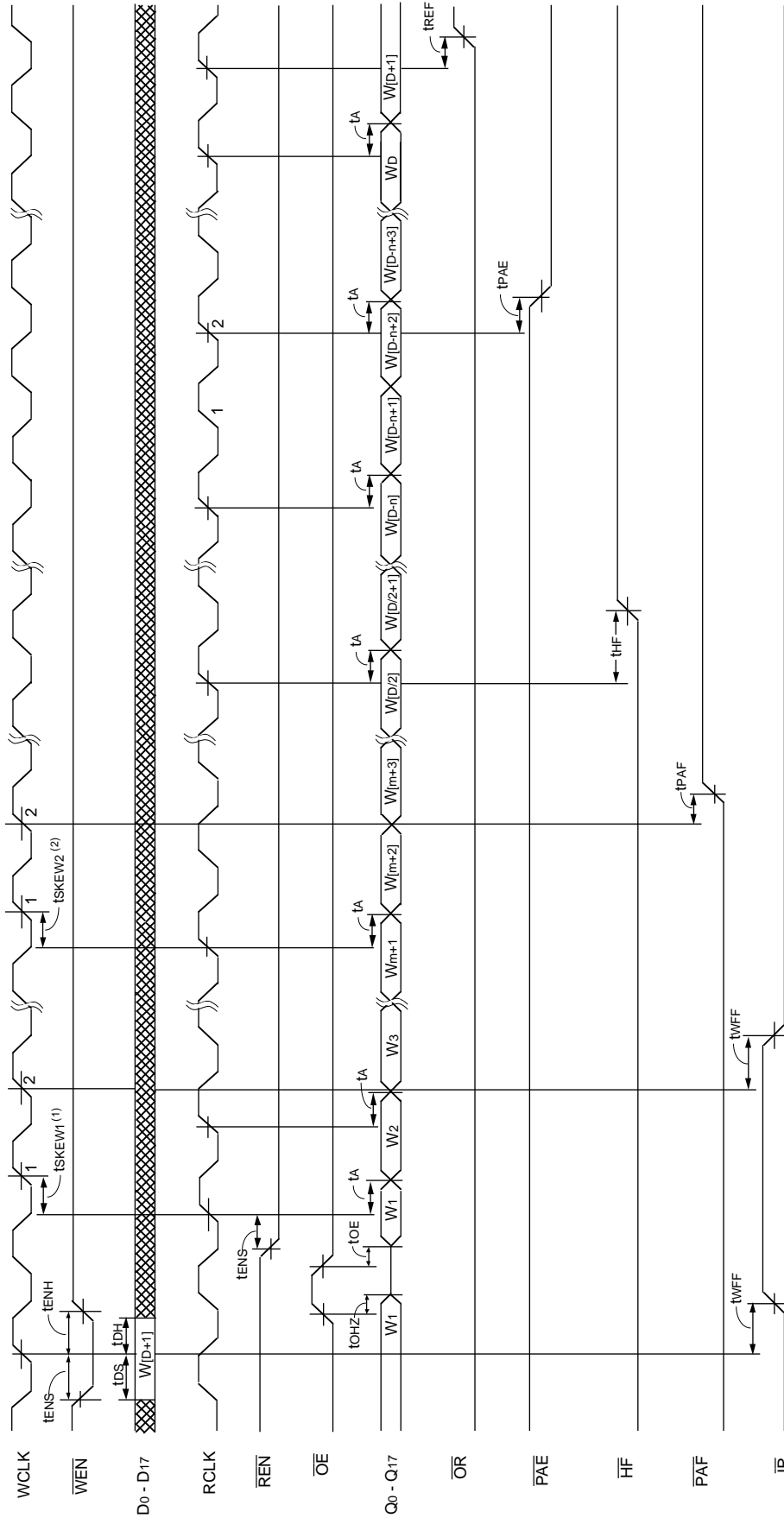

3037.drw 22

**NOTES:**

1.  $t_{SKEW1}$  is the minimum time between a rising RCLK edge and a rising WCLK edge to guarantee that  $\overline{IR}$  will go LOW (after one WCLK cycle plus  $t_{WFF}$ ). If the time between the rising edge of RCLK and the rising edge of WCLK is less than  $t_{SKEW1}$ , then the  $\overline{IR}$  assertion may be delayed an extra WCLK cycle.
2.  $t_{SKEW2}$  is the minimum time between a rising RCLK edge and a rising WCLK edge for PAF to go HIGH (after one WCLK cycle plus  $t_{PAE}$ ). If the time between the rising edge of RCLK and the rising edge of WCLK is less than  $t_{SKEW2}$ , then the PAF deassertion may be delayed an extra WCLK cycle.
3.  $\overline{LD} = \text{HIGH}$
4. PAE Offset = n, PAF offset = m, D = maximum FIFO depth = 8,192 words for the IDT72255, 16,384 words for the IDT72265.

Figure 19. Read Timing (First Word Fall Through Mode)

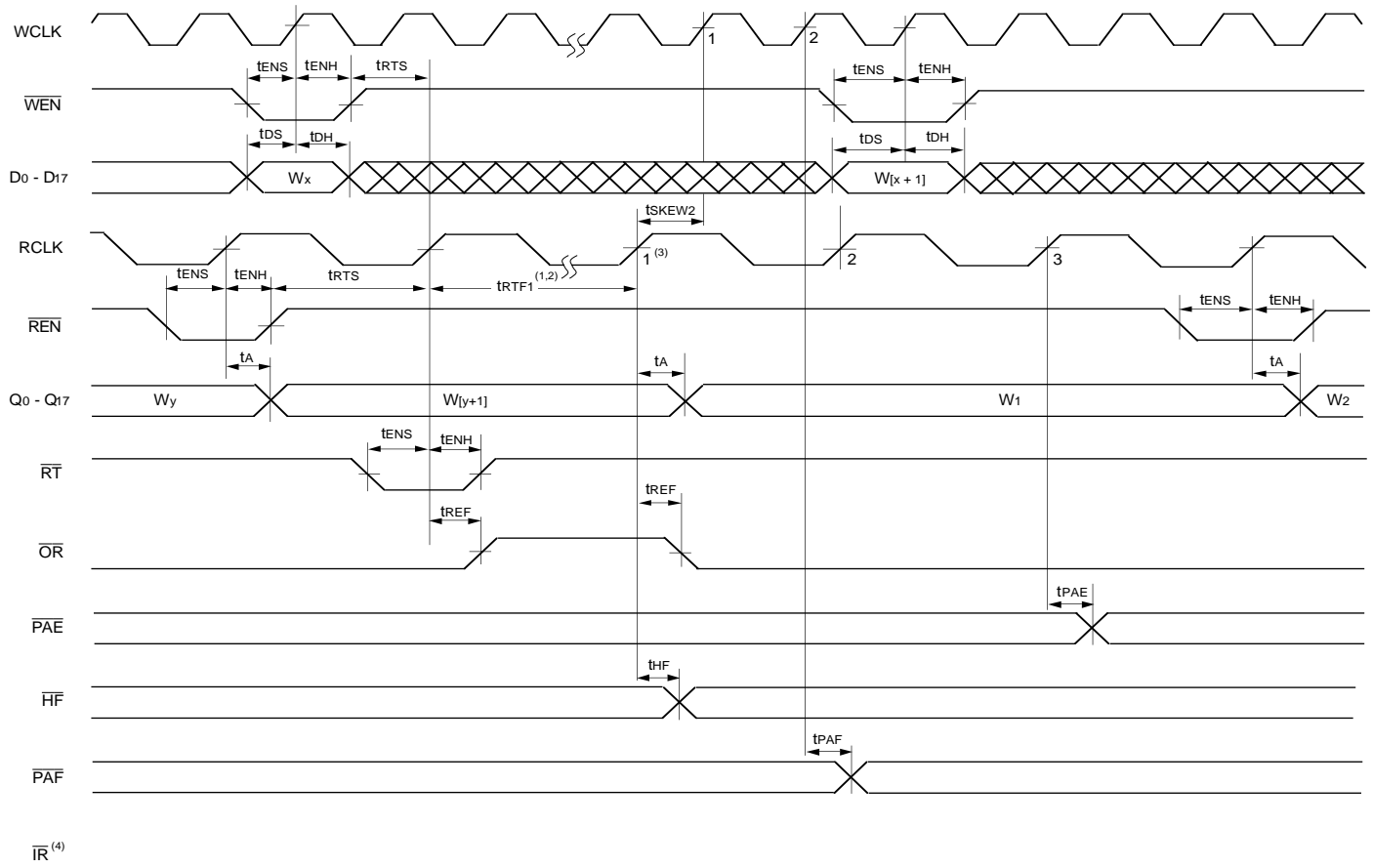

3037 drw 23

**NOTES:**

1.  $t_{RTF2}$  contribute a variable delay to the overall retransmit time:  
 $t_{RTF2\ max} = 14 \cdot T_i + 4 \cdot T_{RCLK}$  (in ns)  
 Where  $T_i$  is either the RCLK or the WCLK period, whichever is shorter, and  $T_{RCLK}$  is the RCLK period.
2. Retransmit set up is complete after  $\overline{OR}$  returns LOW, only then can a read operation begin. Write operations are permitted after one of two conditions have been met:  $\overline{OR}$  is LOW or 14 cycles of the faster clock (RCLK or WCLK) have elapsed since the RCLK rising edge enabled by the  $\overline{RT}$  pulse.
3. Following Retransmit Setup, the rising edge of RCLK that accesses the first memory location also initiates the updating of  $\overline{HF}$ ,  $\overline{PAE}$ , and  $\overline{PAF}$ .
4. No more than D-2 words (D = 8,192 words for the 72255, 16,384 words for the 72265) should have been written to the FIFO between Reset (Master or Partial) and Retransmit Setup. Therefore,  $\overline{IR}$  will be LOW throughout the Retransmit Setup procedure.
5.  $\overline{OE} = \text{LOW}$

Figure 20. Retransmit Timing (FWFT mode)

## OPERATING CONFIGURATIONS

### SINGLE DEVICE CONFIGURATION

A single IDT72255/72265 may be used when the applica-

tion requirements are for 8,192/16,384 words or less. The IDT72255/72265 can always be used in Single Device Configuration, whether IDT Standard Mode or FWFT Mode has been selected. No special set up procedure is necessary.

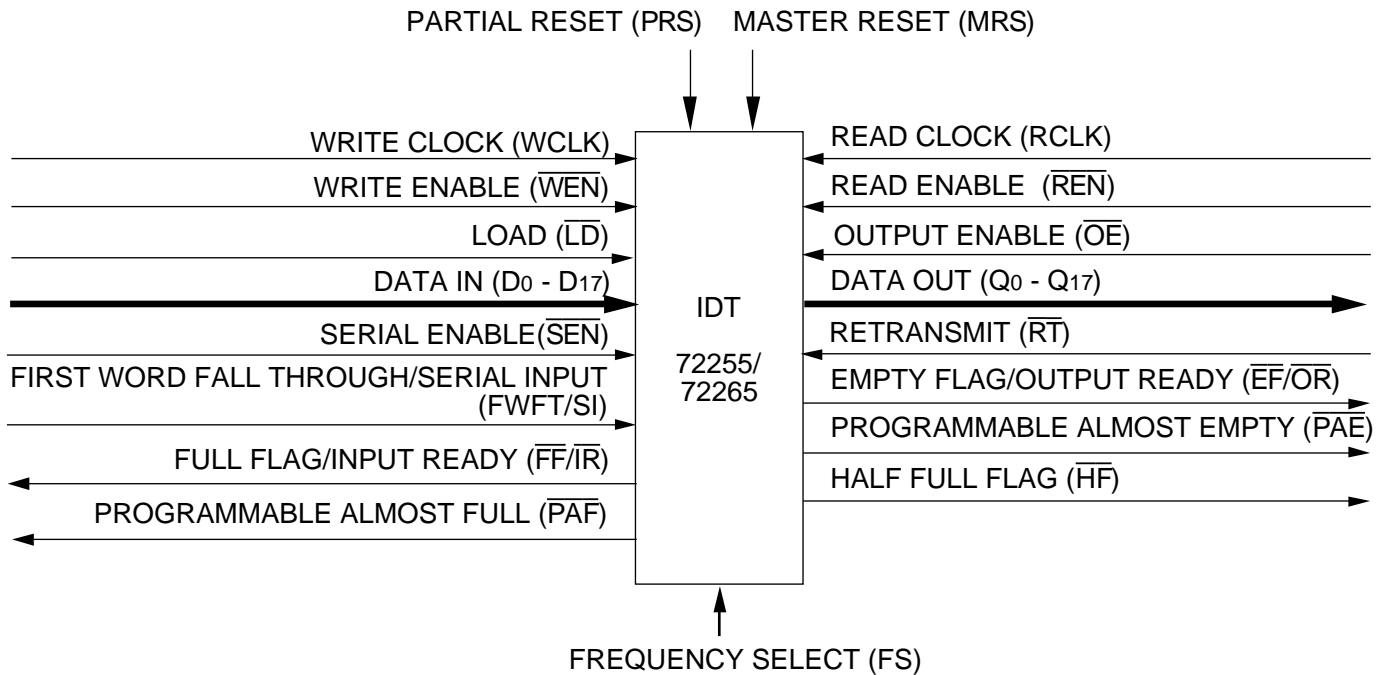

3037 drw 24

Figure 21. Block Diagram of Single 8,192x18/16,384x18 Synchronous FIFO

### WIDTH EXPANSION CONFIGURATION

Word width may be increased simply by connecting together the control signals of multiple devices. Status flags can be detected from any one device. The exceptions are the  $\overline{EF}$  and  $\overline{FF}$  functions in IDT Standard mode and the  $\overline{IR}$  and  $\overline{OR}$  functions in FWFT mode. Because of variations in skew between RCLK and WCLK, it is possible for  $\overline{EF}/\overline{FF}$  deassertion and  $\overline{IR}/\overline{OR}$  assertion to vary by one cycle between FIFOs. In

IDT Standard mode, such problems can be avoided by creating composite flags, that is, ANDing  $\overline{EF}$  of every FIFO, and separately ANDing  $\overline{FF}$  of every FIFO. In FWFT mode, composite flags can be created by ORing  $\overline{OR}$  of every FIFO, and separately ORing  $\overline{IR}$  of every FIFO. Figure 22 demonstrates an 36-word width by using two IDT72255/72265s. Any word width can be attained by adding additional IDT72255/72265s.

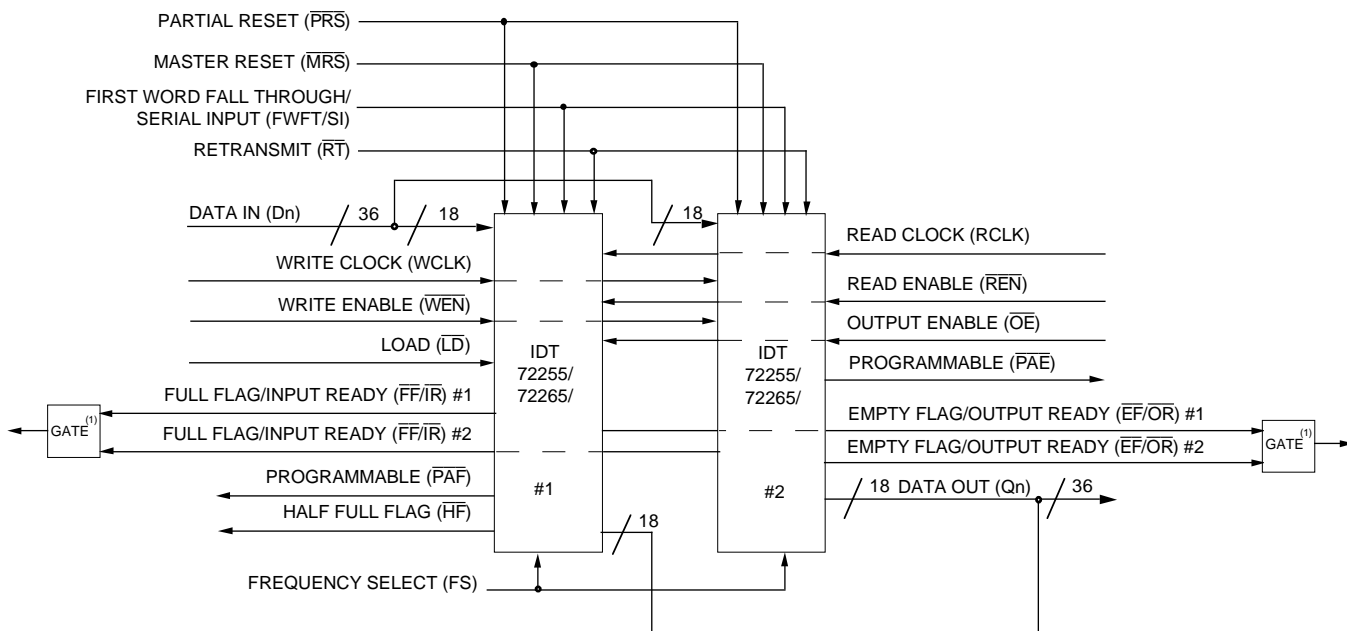

3037 drw 25

**NOTE:**

1. Use an AND gate in IDT Standard mode, an OR gate in FWFT mode.
2. Do not connect any output control signals directly together.

**Figure 22. Block Diagram of 8,192x36/16,384x36 72255/65 Width Expansion**

**DEPTH EXPANSION CONFIGURATION**

The IDT72255/72265 can easily be adapted to applications requiring more than 8,192/16,384 words of buffering. In FWFT mode, the FIFOs can be arranged in series (the data outputs of one FIFO connected to the data inputs of the next)—no external logic necessary. The resulting configuration provides a total depth equivalent to the sum of the depths associated with each single FIFO. Figure 23 shows a depth expansion using two IDT72255/72265s.

Care should be taken to select FWFT mode during Master Reset for all FIFOs in the depth expansion configuration. The

first word written to an empty configuration will pass from one FIFO to the next ("ripple down") until it finally appears at the outputs of the last FIFO in the chain—no read operation is necessary. Each time the data word appears at the outputs of one FIFO, that device's  $\overline{OR}$  line goes LOW, enabling a write to the next FIFO in line.

The  $\overline{OR}$  assertion time is variable and is described with the help of the  $t_{FWL2}$  parameter, which includes including delay caused by clock skew:

$$t_{FWL2} \text{ max.} = 10 * T_f + 3 * T_{RCLK}$$

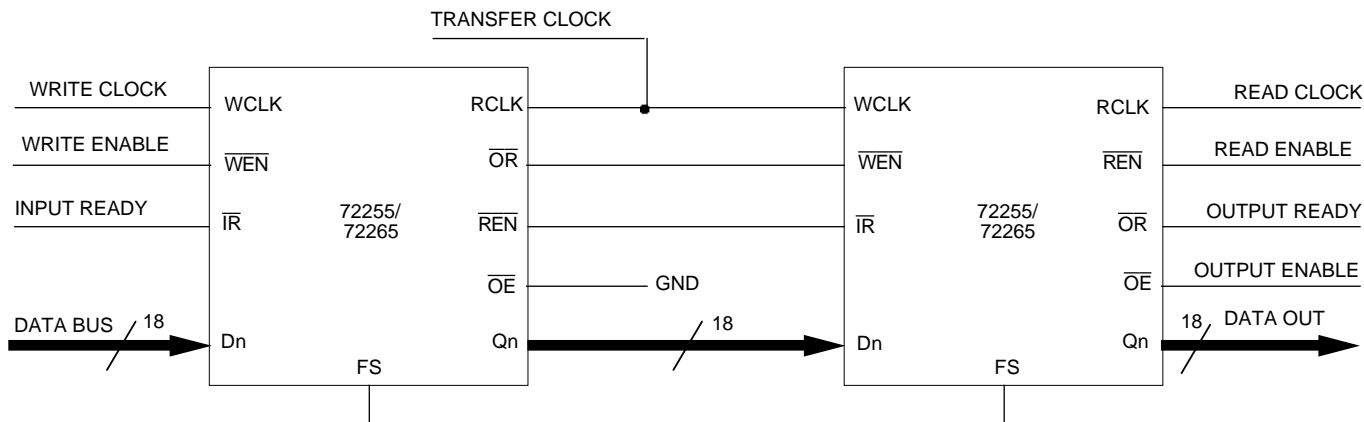

3037 drw 26

**Figure 23. Block Diagram of 16,384x18/32,768x18 Synchronous FIFO Memory With Programmable Flags used in Depth Expansion Configuration**

where TRCLK is the RCLK period and Tf is either the RCLK or the WCLK period, whichever is shorter.

The maximum amount of time it takes for a word to pass from the inputs of the first FIFO to the outputs of the last FIFO in the chain is the sum of the delays for each individual FIFO:

$$t_{FWL2}(1) + t_{FWL2}(2) + \dots + t_{FWL2}(N) + N \cdot TRCLK$$

where N is the number of FIFOs in the expansion.

Note that the additional RCLK term accounts for the time it takes to pass data between FIFOs.

The ripple down delay is only noticeable for the first word written to an empty depth expansion configuration. There will be no delay evident for subsequent words written to the configuration.

The first free location created by reading from a full depth expansion configuration will "bubble up" from the last FIFO to the previous one until it finally moves into the first FIFO of the

chain. Each time a free location is created in one FIFO of the chain, that FIFO's  $\overline{IR}$  line goes LOW, enabling the preceding FIFO to write a word to fill it.

The amount of time it takes for  $\overline{IR}$  of the first FIFO in the chain to assert after a word is read from the last FIFO is the sum of the delays for each individual FIFO:

$$N \cdot (3 \cdot TWCLK)$$

where N is the number of FIFOs in the expansion and TWCLK is the WCLK period. Note that one of the three WCLK cycle accounts for TSKEW1 delays.

In a SuperSync depth expansion, set FS individually for each FIFO in the chain. The Transfer Clock line should be tied to either WCLK or RCLK, whichever is faster. Both these actions result in moving, as quickly as possible, data to the end of the chain and free locations to the beginning of the chain.

## ORDERING INFORMATION

