

**IM Relay**

- Slim line 10x6mm, low profile 5.65mm and min. board-space 60mm<sup>2</sup>
- Switching current 2/5A, switching power 60W/62.5VA and switching voltage 220VDC/250VAC
- Low coil power consumption, 140mW standard, 100mW for high sensitive version, 50mW for ultra high sensitive version and 100mW for bistable version
- High dielectric and surge capability up to 2500Vrms between open contacts and 3000Vrms between coil and contacts
- High mechanical shock resistance up to 300g functional

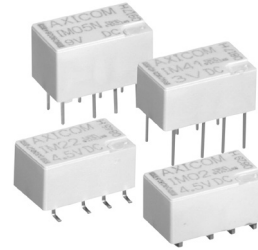

IML



Typical applications

Telecommunication, access and transmission equipment, optical network terminals, modems, office and business equipment, consumer electronics, measurement and test equipment, industrial control, medical equipment, automotive applications

**Approvals**

UL 508 File No. E 111441  
Technical data of approved types on request

Contact Data	standard, C	D	P
	standard and high dielectric version	high current version	high contact stability version
Contact arrangement	2 form C, 2 CO		
Max. switching voltage	220VDC, 250VAC	220VDC, 250VAC	220VDC, 250VAC
Rated current	2A	5A	2A
Limiting continuous current	2A	5A	2A
Switching power	60W, 62.5VA		
Contact material	PdRu +Au covered	AgNi +Au covered	PdRu +Au covered
Contact style	twin contacts		
Minimum switching voltage	100µV		
Initial contact resistance	<50mΩ at 10mA/20mV		
Thermoelectric potential	<10µV		
Operate time	typ. 1ms, max. 3ms		
Release time	typ. 1ms, max. 3ms		
without diode in parallel	typ. 3ms, max. 5ms		
with diode in parallel	typ. 1ms, max. 5ms		
Bounce time max.	typ. 1ms, max. 5ms		

**Contact Data (continued)**

Electrical endurance at contact application 0 (≤30mV/≤10mA)	min. 2.5x10 <sup>6</sup> operations
cable load open end resistive, 125VDC / 0.24A - 30W	min. 2.0x10 <sup>6</sup> operations
resistive, 220 VDC / 0.27A - 60W	min. 5x10 <sup>5</sup> operations
resistive, 250VAC / 0.25A - 62.5VA	min. 1x10 <sup>5</sup> operations
resistive, 30VDC / 1A - 30W	min. 5x10 <sup>5</sup> operations
resistive, 30VDC / 2A - 60W	min. 1x10 <sup>5</sup> operations
Contact ratings, UL	220VDC, 0.24A, 60W 125VDC, 0.24A, 30W 250VAC, 0.25A, 62.5VA 125VAC, 0.5A, 62.5VA 30VDC, 2A, 60W
Mechanical endurance	10 <sup>8</sup> operations

**Coil Data**

Magnetic system	monostable, bistable
Coil voltage range	1.5 to 24VDC

**Coil versions, standard version, monostable, 1 coil**

Coil code	Rated voltage VDC	Operate voltage VDC	Release voltage VDC	Coil resistance Ω±10%	Rated coil power mW
00	1.5	1.13	0.15	16	140
08	2.4	1.80	0.24	41	140
01	3	2.25	0.30	64	140
02	4.5	3.38	0.45	145	140
03	5	3.75	0.50	178	140
04	6	4.50	0.60	257	140
05	9	6.75	0.90	579	140
06	12	9.00	1.20	1029	140
07	24	18.00	2.40	2880	200

All figures are given for coil without pre-energization, at ambient temperature +23°C

**Max. DC load breaking capacity**

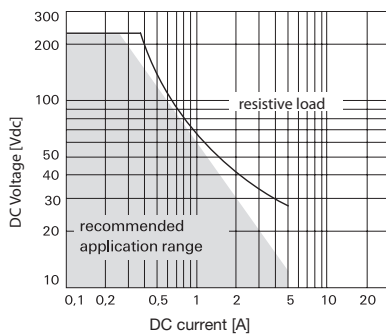

**Coil operating range, standard version**

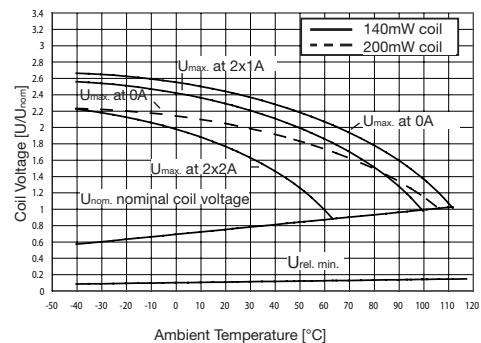

**IM Relay** (Continued)

**Packing**

Tube for THT version  
50 relays per tube, 1000 relays per box

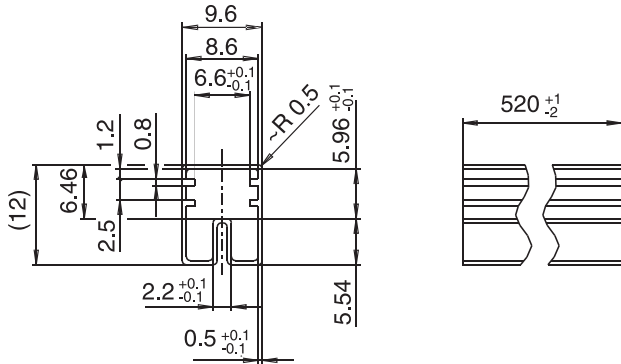

Tape and reel for SMT version  
1000 relays per reel, 1000 or 5000 relays per box

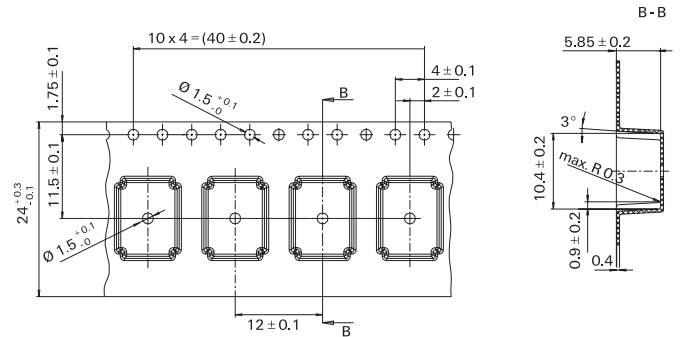

Reel dimensions

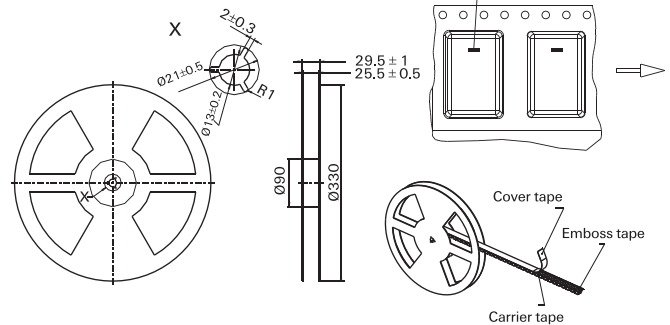

<b>Product code structure</b>	Typical product code	<b>IM</b>	<b>03</b>	<b>G</b>	<b>R</b>
<b>Type</b>	<b>IM</b> Signal Relays IM Series				
<b>Contact arrangement</b>	<b>Blank</b> 2 form C, 2 CO				
<b>Coil</b>	Coil code: please refer to coil versions table				
<b>Performance type</b>	<b>Blank</b> Standard version <b>C</b> High dielectric version <b>D</b> High current version <b>P</b> High contact stability version				
<b>Terminals</b>	<b>T</b> THT - standard <b>J</b> SMT - J-leg <b>N</b> THT - narrow version <b>G</b> SMT - gull wing				
<b>Packing</b>	<b>S</b> Tube <b>R</b> Reel				