

Document Title**128K x8 bit 3.3V Low Power CMOS slow SRAM**Revision History

<u>Revision No</u>	<u>History</u>	<u>Draft Date</u>	<u>Remark</u>
10	Initial Revision History Insert	Jul.14.2000	Final
11	Change the Notch Location of sTSOP - Left-Top => Left-Center	Sep.04.2000	Final
12	Marking Information Add Revised - AC Test Condition Add : 5pF Test Load	Dec.04.2000	Final
13	Changed Logo - HYUNDAI -> hynix - Marking Information Change	Apr.30.2001	Final

ORDERING INFORMATION

Part No.	Speed	Power	Temp.	Package
HY62V8100BLLG	70/85/100	LL-part		SOP
HY62V8100BLLT1	70/85/100	LL-part		TSOP-I(Standard)
HY62V8100BLLR1	70/85/100	LL-part		TSOP-I(Reversed)
HY62V8100BLLST	70/85/100	LL-part		smaller TSOP-I(Standard)
HY62V8100BLLSR	70/85/100	LL-part		smaller TSOP-I(Reversed)
HY62V8100BLLG-E	70/85/100	LL-part	E	SOP
HY62V8100BLLT1-E	70/85/100	LL-part	E	TSOP-I(Standard)
HY62V8100BLLR1-E	70/85/100	LL-part	E	TSOP-I(Reversed)
HY62V8100BLLST-E	70/85/100	LL-part	E	smaller TSOP-I(Standard)
HY62V8100BLLSR-E	70/85/100	LL-part	E	smaller TSOP-I(Reversed)
HY62V8100BLLG-I	70/85/100	LL-part	I	SOP
HY62V8100BLLT1-I	70/85/100	LL-part	I	TSOP-I(Standard)
HY62V8100BLLR1-I	70/85/100	LL-part	I	TSOP-I(Reversed)
HY62V8100BLLST-I	70/85/100	LL-part	I	smaller TSOP-I(Standard)
HY62V8100BLLSR-I	70/85/100	LL-part	I	smaller TSOP-I(Reversed)

Note 1. Blank : Commercial, E : Extended, I : Industrial

ABSOLUTE MAXIMUM RATING (1)

Symbol	Parameter	Rating	Unit	Remark
V _{CC} , V _{IN} , V _{OUT}	Power Supply, Input/Output Voltage	-0.3 to 4.6	V	
T _A	Operating Temperature	0 to 70	°C	HY62V8100B
		-25 to 85	°C	HY62V8100B-E
		-40 to 85	°C	HY62V8100B-I
T _{STG}	Storage Temperature	-65 to 125	°C	
P _D	Power Dissipation	1.0	W	
I _{OUT}	Data Output Current	50	mA	
T _{SOLDER}	Lead Soldering Temperature & Time	260 • 10	°C•sec	

Note

- Stresses greater than those listed under ABSOLUTE MAXIMUM RATINGS may cause permanent damage to the device. This is stress rating only and the functional operation of the device under these or any other conditions above those indicated in the operation of this specification is not implied. Exposure to the absolute maximum rating conditions for extended period may affect reliability.

TRUTH TABLE

/CS1	CS2	/WE	/OE	Mode	I/O	Power
H	X	X	X	Deselected	High-Z	Standby
X	L	X	X	Deselected	High-Z	Standby
L	H	H	H	Output Disabled	High-Z	Active
L	H	H	L	Read	Data Out	Active
L	H	L	X	Write	Data In	Active

Note :

- H=V_{IH}, L=V_{IL}, X=don't care(V_{IH} or V_{IL})

AC CHARACTERISTICS

V_{CC} = 3.0V~3.6V, T_A = 0°C to 70°C / -25°C to 85°C (E) / -25; 85; 100, unless otherwise specified

#	Symbol	Parameter	-70		-85		-10		Unit
			Min.	Max.	Min.	Max.	Min	Max.	
READ CYCLE									
1	t _{RC}	Read Cycle Time	70	-	85	-	100	-	ns
2	t _{AA}	Address Access Time	-	70	-	85	-	100	ns
3	t _{ACS}	Chip Select Access Time	-	70	-	85	-	100	ns
4	t _{OE}	Output Enable to Output Valid	-	40	-	45	-	50	ns
5	t _{CLZ}	Chip Select to Output in Low Z	10	-	10	-	10	-	ns
6	t _{OLZ}	Output Enable to Output in Low Z	5	-	5	-	5	-	ns
7	t _{CHZ}	Chip Deselection to Output in High Z	0	30	0	30	0	30	ns
8	t _{OHZ}	Out Disable to Output in High Z	0	30	0	30	0	30	ns
9	t _{OH}	Output Hold from Address Change	10	-	10	-	15	-	ns
WRITE CYCLE									
10	t _{WC}	Write Cycle Time	70	-	85	-	100	-	ns
11	t _{CW}	Chip Selection to End of Write	60	-	70	-	80	-	ns
12	t _{AW}	Address Valid to End of Write	60	-	70	-	80	-	ns
13	t _{AS}	Address Set-up Time	0	-	0	-	0	-	ns
14	t _{WP}	Write Pulse Width	50	-	55	-	75	-	ns
15	t _{WR}	Write Recovery Time	0	-	0	-	0	-	ns
16	t _{WHZ}	Write to Output in High Z	0	25	0	30	0	35	ns
17	t _{DW}	Data to Write Time Overlap	30	-	40	-	45	-	ns
18	t _{DH}	Data Hold from Write Time	0	-	0	-	0	-	ns
19	t _{OW}	Output Active from End of Write	5	-	5	-	10	-	ns

AC TEST CONDITIONS

T_A = 0°C to 70°C / -25°C to 85°C (E) / -25; 85; 100, unless otherwise specified

Parameter	Value
Input Pulse Level	0.4V to 2.2V
Input Rise and Fall Time	5ns
Input and Output Timing Reference Level	1.5V
Output Load	t _{CLZ} ,t _{OLZ} ,t _{CHZ} ,t _{OHZ} ,t _{WHZ}
	Others

AC TEST LOADS

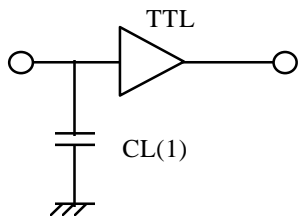

Note : 1 Including jig and scope capacitance

TIMING DIAGRAM

READ CYCLE 1(Note 1,4)

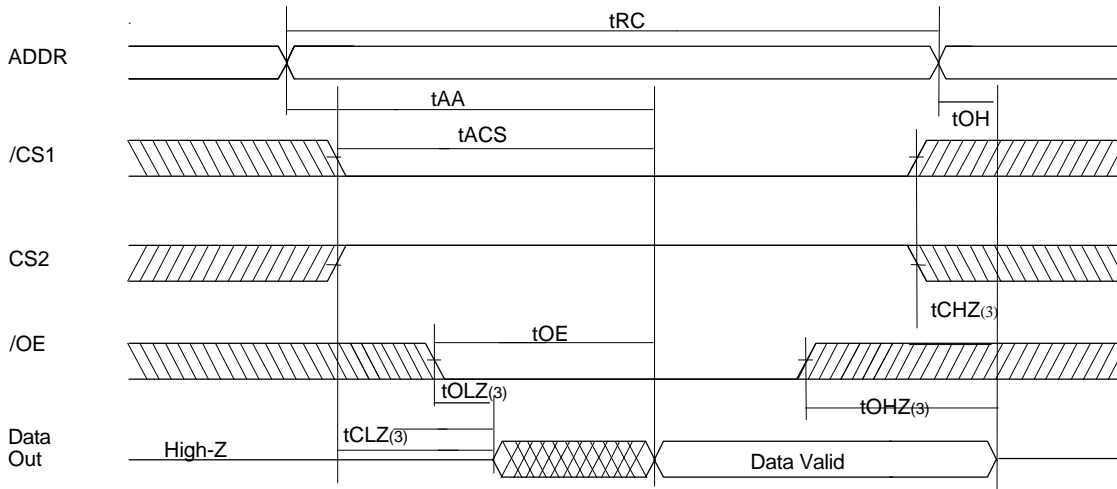

READ CYCLE 2(Note 1,2,4)

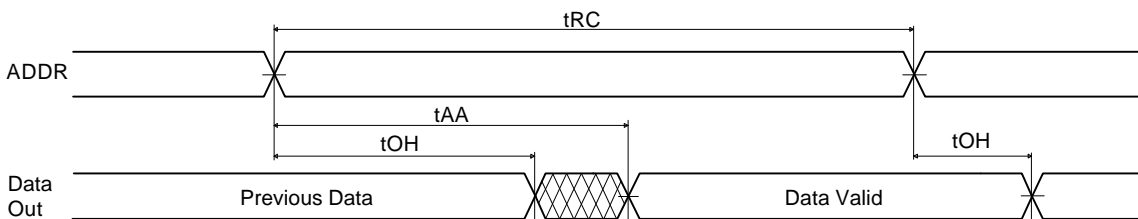

READ CYCLE 3(Note 1,2,4)

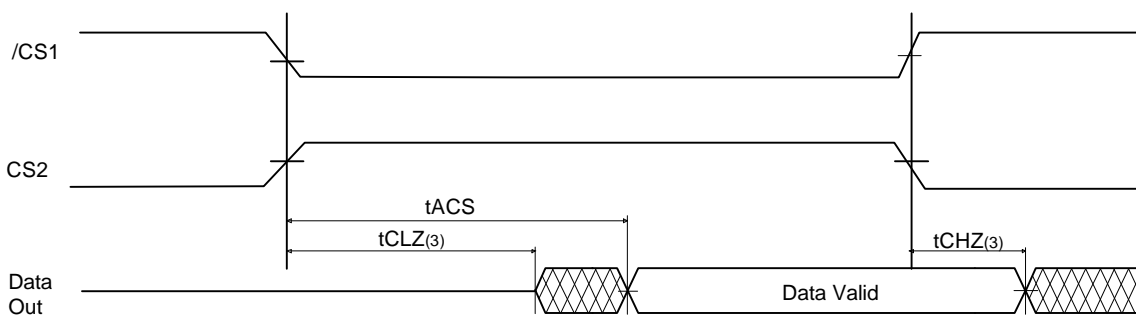

Notes:

1. A read occurs during the overlap of a low /OE, a high /WE, a low /CS1 and a high CS2.
2. /OE = V_{IL}
3. Transition is measured ± 200mV from steady state voltage.
This parameter is sampled and not 100% tested.
4. /CS1 in high for the standby, low for active
CS2 in low for the standby, high for active

WRITE CYCLE 1(1,4,5,8) (/WE Controlled)

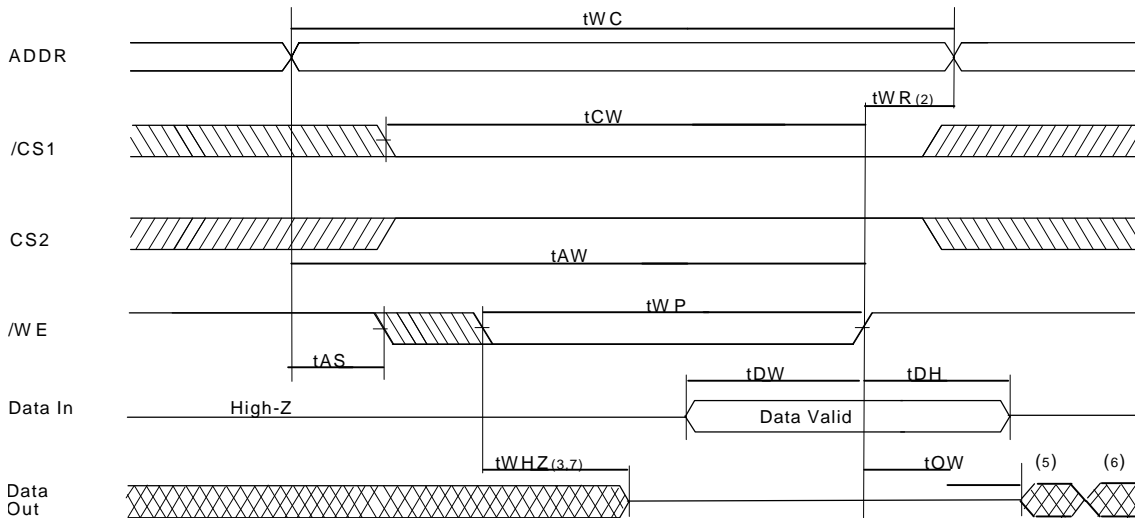

WRITE CYCLE 2 (Note 1,4,5,8) (/CS1, CS2 Controlled)

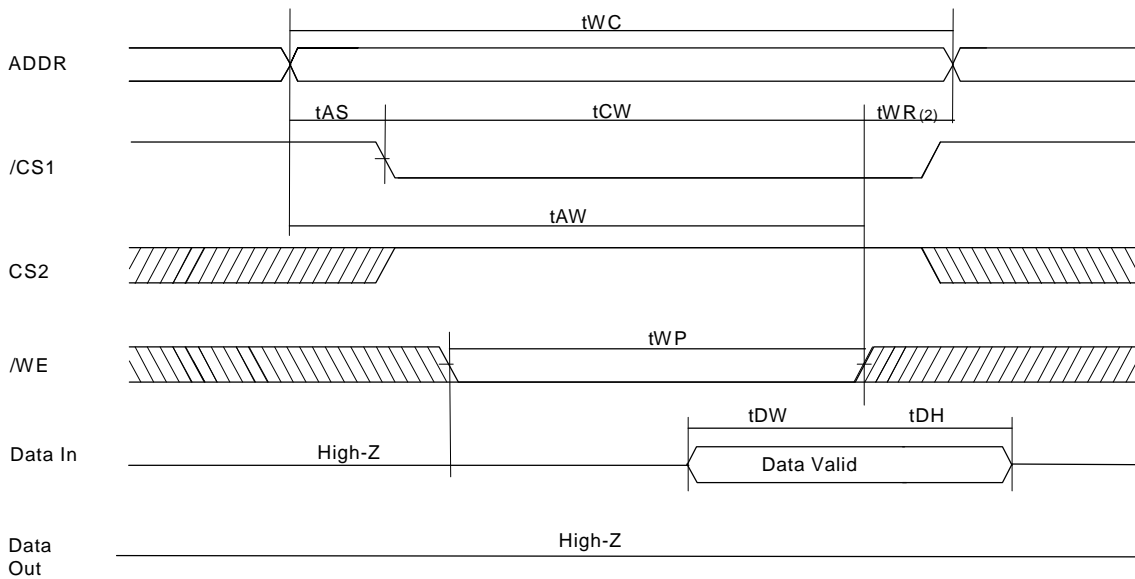

Notes:

1. A write occurs during the overlap of a low /WE, a low /CS1 and a high CS2.
2. t_{WR} is measured from the earlier of /CS1 or /WE going high or CS2 going low to the end of write cycle.
3. During this period, I/O pins are in the output state so that the input signals of opposite phase to the output must not be applied.
4. If the the /CS1 low transition and CS2 high transition occur simultaneously with the /WE low transition or after the /WE transition, outputs remain in a high impedance state.
5. Q(data out) is the same phase with the write data of this write cycle.
6. Q(data out) is the read data of the next address.
7. Transition is measured $\pm 200mV$ from steady state.
This parameter is sampled and not 100% tested.
8. /CS1 in high for the standby, low for active
CS2 in low for the standby, high for active

DATA RETENTION ELECTRIC CHARACTERISTIC

TA=0°C to 70°C / -25°C to 85°C (E) / -25; 0 to 85; 0

Sym	Parameter	Test Condition	Min	Typ	Max	Unit	
VDR	Vcc for Data Retention	/CS1 ≥ Vcc-0.2V or CS2 ≤ 0.2V, VIN ≥ Vcc-0.2V or VIN ≤ Vss+0.2V	2.0	-	-	V	
ICCDR	Data Retention Current	HY62V8100B	Vcc=3.0V,	-	0.5	10	uA
		HY62V8100B-E	/CS1 ≥ Vcc - 0.2V or CS2 ≤ 0.2V,	-	0.5	15	uA
		HY62V8100B-I	VIN ≥ Vcc-0.2V or VIN ≤ Vss+0.2V	-	0.5	15	uA
tCDR	Chip Deselect to Data Retention Time	See Data Retention Timing Diagram	0	-	-	ns	
tR	Operating Recovery Time		tRC(2)	-	-	ns	

Notes:

1. Typical values are under the condition of TA = 25°C.
2. tRC is read cycle time.

DATA RETENTION TIMING DIAGRAM 1

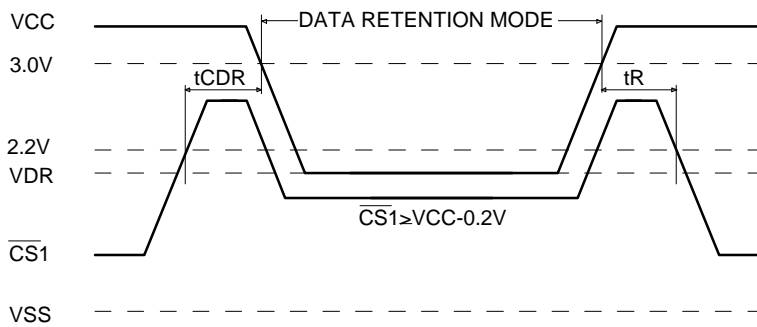

DATA RETENTION TIMING DIAGRAM 2

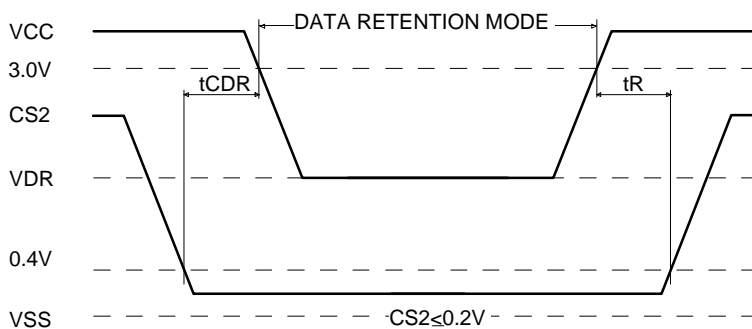

PACKAGE INFORMATION

32pin 525mil Small Outline Package(G)

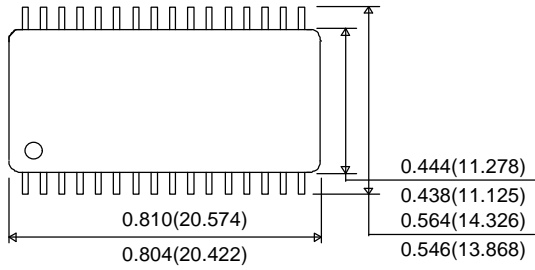

UNIT : INCH(mm)

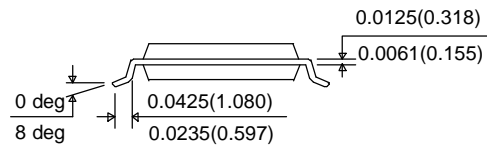
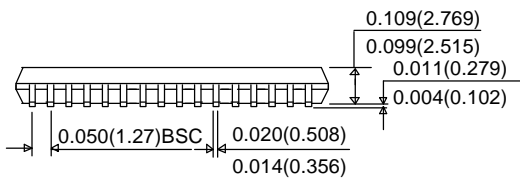

32pin 8x20mm Thin Small Outline Package Standard(T1)

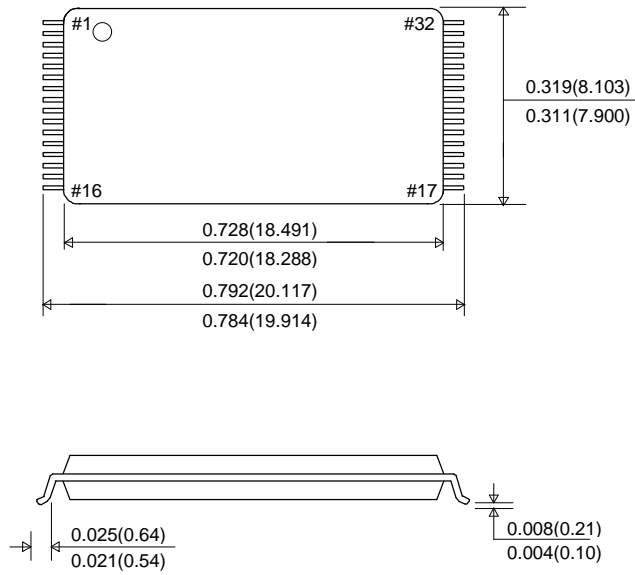

UNIT : INCH(mm)

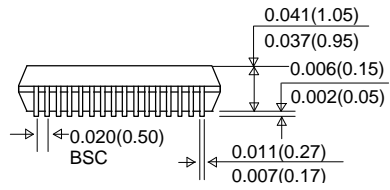

32pin 8x20mm Thin Small Outline Package Reversed(R1)

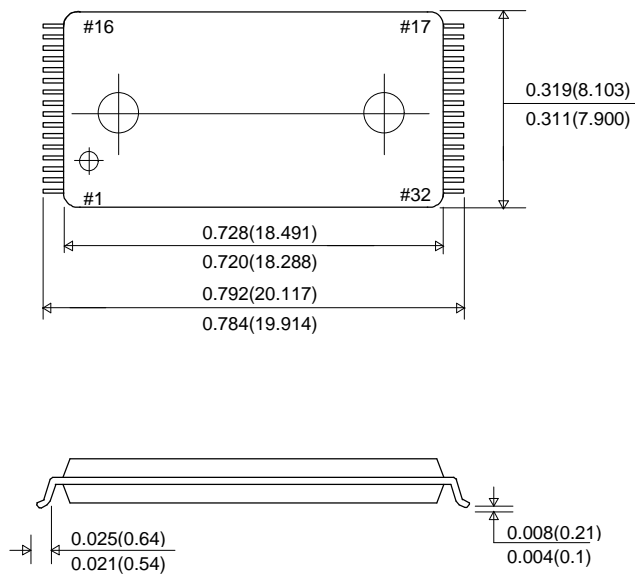

UNIT : INCH(mm)

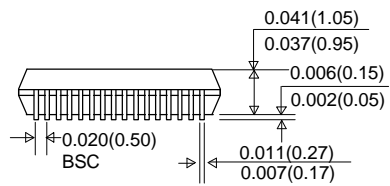

32pin 8x13.4mm Samller Thin Small Outline Package Standard(ST)

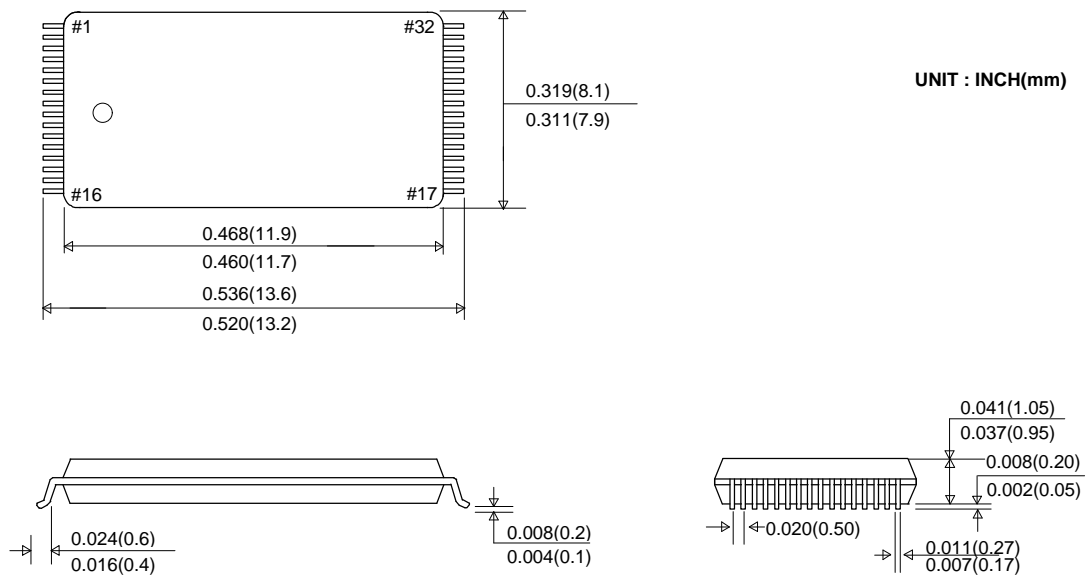

32pin 8x13.4mm Smaller Thin Small Outline Package Reversed(SR)

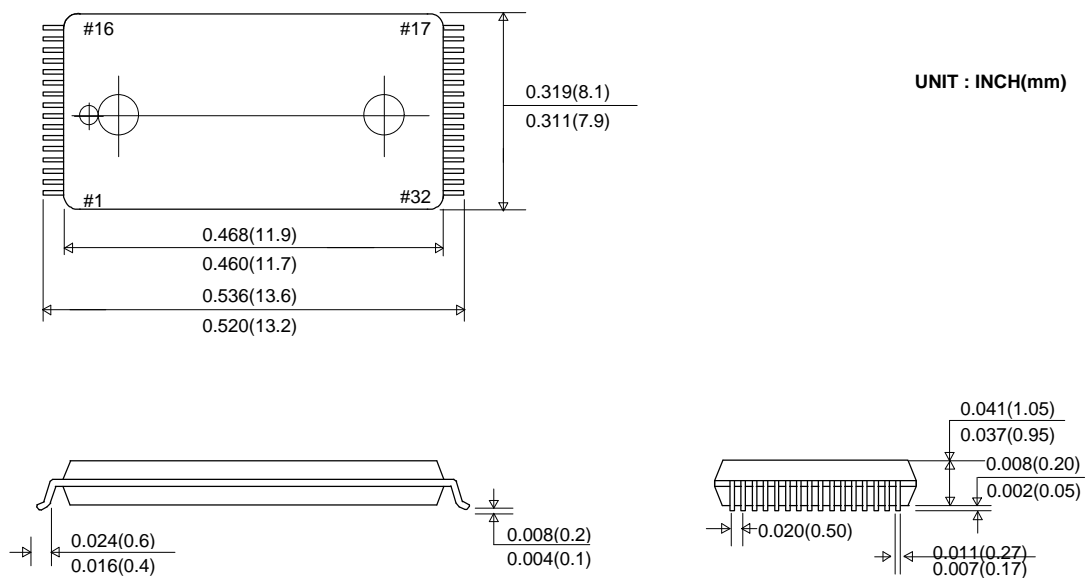

MARKING INFORMATION

Package	Marking Example																																																
SOP	<div style="border: 1px solid black; padding: 5px; margin-bottom: 5px;"> <table style="width: 100%; border-collapse: collapse;"> <tr> <td style="border: 1px solid black; padding: 2px;">h</td><td style="border: 1px solid black; padding: 2px;">y</td><td style="border: 1px solid black; padding: 2px;">n</td><td style="border: 1px solid black; padding: 2px;">i</td><td style="border: 1px solid black; padding: 2px;">x</td><td style="border: 1px solid black; padding: 2px;"> </td><td style="border: 1px solid black; padding: 2px;"> </td><td style="border: 1px solid black; padding: 2px;"> </td><td style="border: 1px solid black; padding: 2px;"> </td><td style="border: 1px solid black; padding: 2px;"> </td><td style="border: 1px solid black; padding: 2px;">K</td><td style="border: 1px solid black; padding: 2px;">O</td><td style="border: 1px solid black; padding: 2px;">R</td><td style="border: 1px solid black; padding: 2px;">E</td><td style="border: 1px solid black; padding: 2px;">A</td> </tr> <tr> <td style="border: 1px solid black; padding: 2px;">H</td><td style="border: 1px solid black; padding: 2px;">Y</td><td style="border: 1px solid black; padding: 2px;">6</td><td style="border: 1px solid black; padding: 2px;">2</td><td style="border: 1px solid black; padding: 2px;">V</td><td style="border: 1px solid black; padding: 2px;">8</td><td style="border: 1px solid black; padding: 2px;">1</td><td style="border: 1px solid black; padding: 2px;">0</td><td style="border: 1px solid black; padding: 2px;">0</td><td style="border: 1px solid black; padding: 2px;">B</td><td style="border: 1px solid black; padding: 2px;"> </td><td style="border: 1px solid black; padding: 2px;"> </td><td style="border: 1px solid black; padding: 2px;"> </td><td style="border: 1px solid black; padding: 2px;"> </td><td style="border: 1px solid black; padding: 2px;"> </td> </tr> <tr> <td style="border: 1px solid black; padding: 2px;">y</td><td style="border: 1px solid black; padding: 2px;">y</td><td style="border: 1px solid black; padding: 2px;">w</td><td style="border: 1px solid black; padding: 2px;">w</td><td style="border: 1px solid black; padding: 2px;">p</td><td style="border: 1px solid black; padding: 2px;"> </td><td style="border: 1px solid black; padding: 2px;"> </td><td style="border: 1px solid black; padding: 2px;"> </td><td style="border: 1px solid black; padding: 2px;"> </td><td style="border: 1px solid black; padding: 2px;"> </td><td style="border: 1px solid black; padding: 2px;">c</td><td style="border: 1px solid black; padding: 2px;">c</td><td style="border: 1px solid black; padding: 2px;">G</td><td style="border: 1px solid black; padding: 2px;">-</td><td style="border: 1px solid black; padding: 2px;">s</td><td style="border: 1px solid black; padding: 2px;">s</td><td style="border: 1px solid black; padding: 2px;">t</td> </tr> </table> </div>	h	y	n	i	x						K	O	R	E	A	H	Y	6	2	V	8	1	0	0	B						y	y	w	w	p						c	c	G	-	s	s	t	
h	y	n	i	x						K	O	R	E	A																																			
H	Y	6	2	V	8	1	0	0	B																																								
y	y	w	w	p						c	c	G	-	s	s	t																																	
TSOP-I	<div style="border: 1px solid black; padding: 5px; margin-bottom: 5px;"> <table style="width: 100%; border-collapse: collapse;"> <tr> <td style="border: 1px solid black; padding: 2px;">h</td><td style="border: 1px solid black; padding: 2px;">y</td><td style="border: 1px solid black; padding: 2px;">n</td><td style="border: 1px solid black; padding: 2px;">i</td><td style="border: 1px solid black; padding: 2px;">x</td><td style="border: 1px solid black; padding: 2px;"> </td><td style="border: 1px solid black; padding: 2px;"> </td><td style="border: 1px solid black; padding: 2px;"> </td><td style="border: 1px solid black; padding: 2px;"> </td><td style="border: 1px solid black; padding: 2px;"> </td><td style="border: 1px solid black; padding: 2px;">K</td><td style="border: 1px solid black; padding: 2px;">O</td><td style="border: 1px solid black; padding: 2px;">R</td><td style="border: 1px solid black; padding: 2px;">E</td><td style="border: 1px solid black; padding: 2px;">A</td> </tr> <tr> <td style="border: 1px solid black; padding: 2px;">H</td><td style="border: 1px solid black; padding: 2px;">Y</td><td style="border: 1px solid black; padding: 2px;">6</td><td style="border: 1px solid black; padding: 2px;">2</td><td style="border: 1px solid black; padding: 2px;">V</td><td style="border: 1px solid black; padding: 2px;">8</td><td style="border: 1px solid black; padding: 2px;">1</td><td style="border: 1px solid black; padding: 2px;">0</td><td style="border: 1px solid black; padding: 2px;">0</td><td style="border: 1px solid black; padding: 2px;">B</td><td style="border: 1px solid black; padding: 2px;"> </td><td style="border: 1px solid black; padding: 2px;"> </td><td style="border: 1px solid black; padding: 2px;"> </td><td style="border: 1px solid black; padding: 2px;"> </td><td style="border: 1px solid black; padding: 2px;"> </td> </tr> <tr> <td style="border: 1px solid black; padding: 2px;">y</td><td style="border: 1px solid black; padding: 2px;">y</td><td style="border: 1px solid black; padding: 2px;">w</td><td style="border: 1px solid black; padding: 2px;">w</td><td style="border: 1px solid black; padding: 2px;">p</td><td style="border: 1px solid black; padding: 2px;"> </td><td style="border: 1px solid black; padding: 2px;"> </td><td style="border: 1px solid black; padding: 2px;"> </td><td style="border: 1px solid black; padding: 2px;"> </td><td style="border: 1px solid black; padding: 2px;"> </td><td style="border: 1px solid black; padding: 2px;">c</td><td style="border: 1px solid black; padding: 2px;">c</td><td style="border: 1px solid black; padding: 2px;">T</td><td style="border: 1px solid black; padding: 2px;">1</td><td style="border: 1px solid black; padding: 2px;">-</td><td style="border: 1px solid black; padding: 2px;">s</td><td style="border: 1px solid black; padding: 2px;">s</td><td style="border: 1px solid black; padding: 2px;">t</td> </tr> </table> </div>	h	y	n	i	x						K	O	R	E	A	H	Y	6	2	V	8	1	0	0	B						y	y	w	w	p						c	c	T	1	-	s	s	t
h	y	n	i	x						K	O	R	E	A																																			
H	Y	6	2	V	8	1	0	0	B																																								
y	y	w	w	p						c	c	T	1	-	s	s	t																																
sTSOP	<div style="border: 1px solid black; padding: 5px; margin-bottom: 5px;"> <table style="width: 100%; border-collapse: collapse;"> <tr> <td style="border: 1px solid black; padding: 2px;">H</td><td style="border: 1px solid black; padding: 2px;">Y</td><td style="border: 1px solid black; padding: 2px;">6</td><td style="border: 1px solid black; padding: 2px;">2</td><td style="border: 1px solid black; padding: 2px;">V</td><td style="border: 1px solid black; padding: 2px;">8</td><td style="border: 1px solid black; padding: 2px;">1</td><td style="border: 1px solid black; padding: 2px;">0</td><td style="border: 1px solid black; padding: 2px;">0</td><td style="border: 1px solid black; padding: 2px;">B</td> </tr> <tr> <td style="border: 1px solid black; padding: 2px;">c</td><td style="border: 1px solid black; padding: 2px;">c</td><td style="border: 1px solid black; padding: 2px;">S</td><td style="border: 1px solid black; padding: 2px;">T</td><td style="border: 1px solid black; padding: 2px;">-</td><td style="border: 1px solid black; padding: 2px;">s</td><td style="border: 1px solid black; padding: 2px;">s</td><td style="border: 1px solid black; padding: 2px;">t</td><td style="border: 1px solid black; padding: 2px;"> </td><td style="border: 1px solid black; padding: 2px;"> </td> </tr> <tr> <td style="border: 1px solid black; padding: 2px;">y</td><td style="border: 1px solid black; padding: 2px;">y</td><td style="border: 1px solid black; padding: 2px;">w</td><td style="border: 1px solid black; padding: 2px;">w</td><td style="border: 1px solid black; padding: 2px;">p</td><td style="border: 1px solid black; padding: 2px;"> </td><td style="border: 1px solid black; padding: 2px;"> </td><td style="border: 1px solid black; padding: 2px;"> </td><td style="border: 1px solid black; padding: 2px;"> </td><td style="border: 1px solid black; padding: 2px;"> </td><td style="border: 1px solid black; padding: 2px;">K</td><td style="border: 1px solid black; padding: 2px;">O</td><td style="border: 1px solid black; padding: 2px;">R</td> </tr> </table> </div>	H	Y	6	2	V	8	1	0	0	B	c	c	S	T	-	s	s	t			y	y	w	w	p						K	O	R															
H	Y	6	2	V	8	1	0	0	B																																								
c	c	S	T	-	s	s	t																																										
y	y	w	w	p						K	O	R																																					

Index	
<ul style="list-style-type: none"> • hynix • KOREA / KOR • HY62V8100B • yy • ww • p • cc 	<ul style="list-style-type: none"> : hynix Logo : Origin Country : Part Name : Year (ex : 00 = year 2000, 01 = year 2001) : Work Week (ex : 12 = ww12) : Process Code : Power Consumption <ul style="list-style-type: none"> - L : Low Power - LL : Low Low Power
<ul style="list-style-type: none"> • G / T1 / ST 	<ul style="list-style-type: none"> : Package Type <ul style="list-style-type: none"> - G : SOP - T1 : TSOP-I - ST : sTSOP
<ul style="list-style-type: none"> • ss 	<ul style="list-style-type: none"> : Speed <ul style="list-style-type: none"> - 70 : 70ns - 85 : 85ns
<ul style="list-style-type: none"> • t 	<ul style="list-style-type: none"> : Temperature <ul style="list-style-type: none"> - Blank : Commercial (0 ~ 70 °C) - E : Extended (-25 ~ 85 °C) - I : Industrial (-40 ~ 85 °C)
<p>Note</p> <ul style="list-style-type: none"> - Capital Letter - Small Letter 	<ul style="list-style-type: none"> : Fixed Item : Non-fixed Item (Except hynix)