

80V, 0.5A Three Phase Driver

The HIP4086 is a Three Phase Bridge N-Channel MOSFET driver IC. The HIP4086 is specifically targeted for PWM motor control. It makes bridge based designs simple and flexible. Like the HIP4081, the HIP4086 has a flexible input protocol for driving every possible switch combination. Unlike the HIP4081, the user can override the shoot-through protection for switched reluctance applications. The HIP4086 has reduced drive current compared to the HIP4081 (0.5A vs 2.5A) and a much wider range of programmable dead times (0.25µs to 4.5µs) - like the HIP4082. The HIP4086 is suitable for applications requiring DC to 100kHz. Unlike the previous family members, the HIP4086 has a programmable undervoltage set point.

Also refer to the HIP4083, three phase upper only MOSFET driver, for a lower current solution optimized for smaller motors.

Ordering Information

| PART NUMBER | TEMP. RANGE (°C) | PACKAGE | PKG. NO. |
|-------------|------------------|------------|----------|
| HIP4086AB | -40 to 125 | 24 Ld SOIC | M24.3 |
| HIP4086AP | -40 to 125 | 24 Ld PDIP | E24.3 |

Pinout

**HIP4086
(PDIP, SOIC)
TOP VIEW**

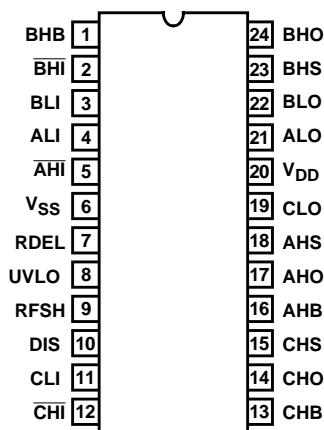

Features

- Independently Drives 6 N-Channel MOSFETs in Three Phase Bridge Configuration
- Bootstrap Supply Max Voltage to 95VDC
- Bias Supply Operation from 7V to 15V
- 1.25A Peak Turn-Off Current
- User-Programmable Dead Time (0.25µs to 4.5µs)
- Charge-Pump and Bootstrap Maintain Upper Bias Supplies
- Programmable Bootstrap Refresh Time
- Drives 1000pF Load with Typical Rise Time of 20ns and Fall Time of 10ns
- DIS (Disable) Overrides Input Control
- Input Logic Thresholds Compatible with 5V to 15V Logic Levels
- Dead Time Disable Capability
- Programmable Undervoltage Set Point

Applications

- Brushless Motors
- AC Motor Drives
- Switched Reluctance Motor Drives
- Battery Powered Vehicles

Application Block Diagram

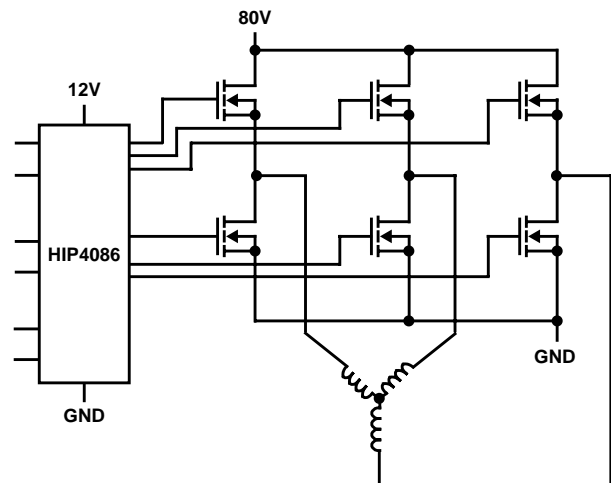

Functional Block Diagram (1/3 of HIP4086)

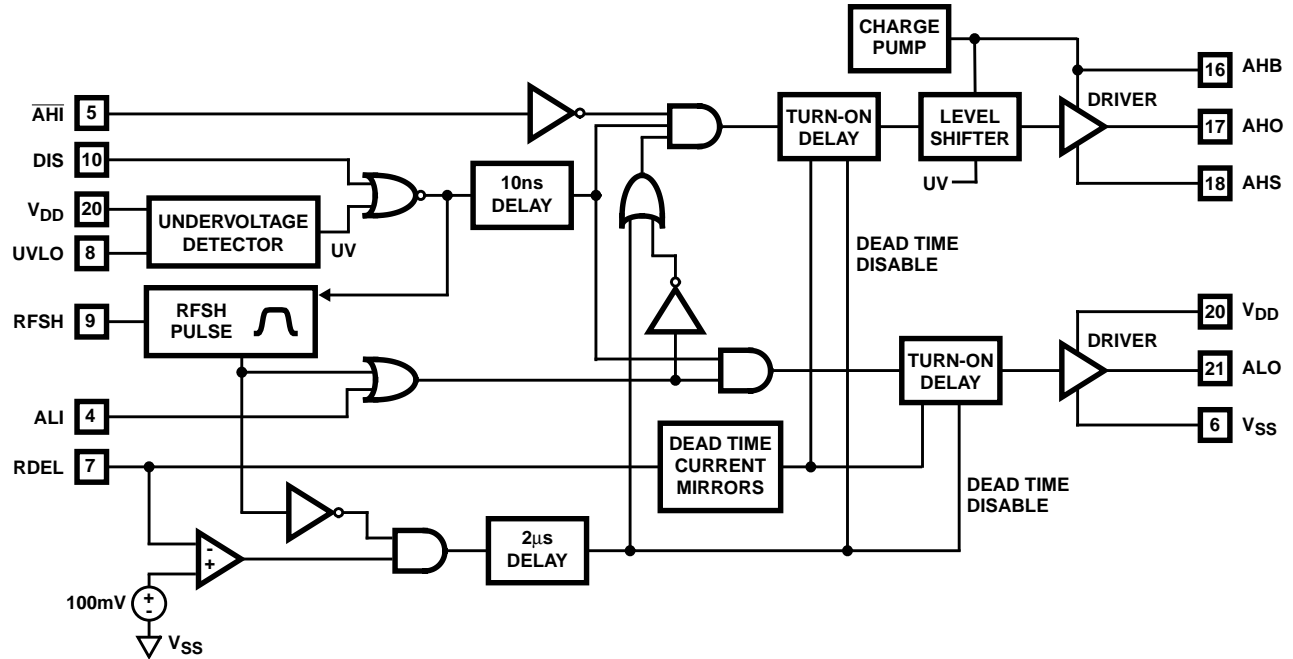

TRUTH TABLE

| INPUT | | | OUTPUT | | | |
|---------------|--|----|--------|--------|---------------|---------------|
| ALI, BLI, CLI | $\overline{\text{AH}}$, $\overline{\text{BH}}$, $\overline{\text{CH}}$ | UV | DIS | RDEL | ALO, BLO, CLO | AHO, BHO, CHO |
| X | X | X | 1 | X | 0 | 0 |
| X | X | 1 | X | X | 0 | 0 |
| 1 | X | 0 | 0 | >100mV | 1 | 0 |
| 0 | 0 | 0 | 0 | X | 0 | 1 |
| 0 | 1 | 0 | 0 | X | 0 | 0 |
| 1 | 0 | 0 | 0 | <100mV | 1 | 1 |

NOTE: X signifies that input can be either a "1" or "0".

Typical Application (PWM Mode Switching)

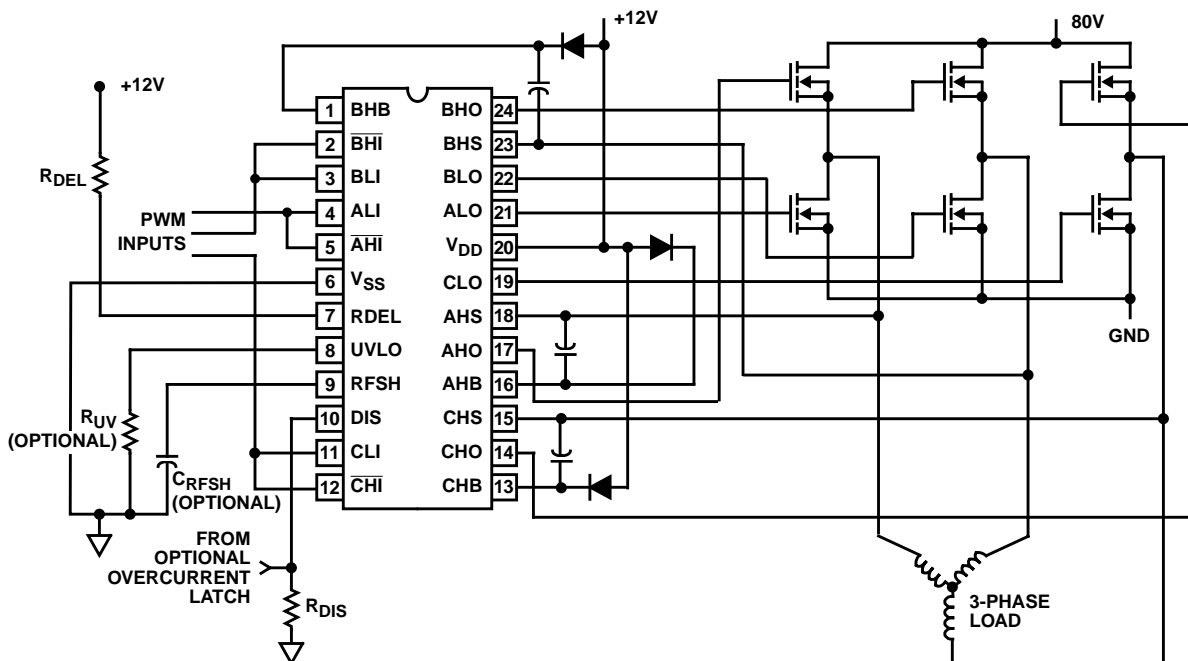

Pin Descriptions

| PIN NUMBER | SYMBOL | DESCRIPTION |
|----------------|--|---|
| 16 1 13 | AHB BHB CHB (xHB) | High-Side Bootstrap supplies. One external bootstrap diode and one capacitor are required for each. Connect cathode of bootstrap diode and positive side of bootstrap capacitor to each xHB pin. |
| 5 2 12 | $\overline{\text{AHI}}$ $\overline{\text{BHI}}$ $\overline{\text{CHI}}$ (xHI) | High-Side Logic Level Inputs. Logic at these three pins controls the three high side output drivers, AHO (Pin 17), BHO (Pin 24) and CHO (Pin 14). When $\overline{\text{xHI}}$ is low, xHO is high. When $\overline{\text{xHI}}$ is high, xHO is low. Unless the dead time is disabled by connecting RDEL (Pin 7) to ground, the low side input of each phase will override the corresponding high side input on that phase - see Truth Table on previous page. If RDEL is tied to ground, dead time is disabled and the outputs follow the inputs. Care must be taken to avoid shoot-through in this application. DIS (Pin 10) also overrides the high side inputs. $\overline{\text{xHI}}$ can be driven by signal levels of 0V to 15V (no greater than V_{DD}). An internal 100 μ A pull-up to V_{DD} will hold each xHI high if the pins are not driven. |
| 4 3 11 | ALI BLI CLI (xLI) | Low-Side Logic Level Inputs. Logic at these three pins controls the three low side output drivers ALO (Pin 21), BLO (Pin 22) and CLO (Pin 19). If the upper inputs are grounded then the lower inputs control both xLO and xHO drivers, with the dead time set by the resistor at RDEL (Pin 7). DIS (Pin 10) high level input overrides xLI, forcing all outputs low. xLI can be driven by signal levels of 0V to 15V (no greater than V_{DD}). An internal 100 μ A pull-up to V_{DD} will hold xLI high if these pins are not driven. |
| 6 | V_{SS} | Ground. Connect the sources of the Low-Side power MOSFETs to this pin. |
| 7 | RDEL | Dead Time Setting. Connect a resistor from this pin to V_{DD} to set timing current that defines the dead time between drivers - see Figure 15. All drivers turn-off with no adjustable delay, so the RDEL resistor guarantees no shoot-through by delaying the turn-on of all drivers. When RDEL is tied to V_{SS} , both upper and lowers can be commanded on simultaneously. While not necessary in most applications, a decoupling capacitor of 0.1 μ F or smaller may be connected between RDEL and V_{SS} . |
| 8 | UVLO | Undervoltage Setting. A resistor can be connected between this pin and V_{SS} to program the undervoltage set point, see Figure 16. With this pin not connected, the undervoltage disable is typically 6.6V. When this pin is tied to V_{DD} , the undervoltage disable is typically 6.2V. |
| 9 | RFSH | Refresh Pulse Setting. An external capacitor can be connected from this pin to V_{SS} to increase the length of the start up refresh pulse - see Figure 14. If this pin is not connected, the refresh pulse is typically 1.5 μ s. |
| 10 | DIS | Disable Input. Logic level input that when taken high sets all six outputs low. DIS high overrides all other inputs. With DIS low, the outputs are controlled by the other inputs. DIS can be driven by signal levels of 0V to 15V (no greater than V_{DD}). An internal 100 μ A pull-up to V_{DD} will hold DIS high if this pin is not driven. |
| 17 24 14 | AHO BHO CHO (xHO) | High-Side Outputs. Connect to the gates of the High-Side power MOSFETs in each phase. |
| 15 23 15 | AHS BHS CHS (xHS) | High-Side Source Connection. Connect the sources of the High-Side power MOSFETs to these pins. The negative side of the bootstrap capacitors should also be connected to these pins. |
| 20 | V_{DD} | Positive Supply. Decouple this pin to V_{SS} (Pin 6). |
| 21 22 19 | ALO BLO CLO (xLO) | Low-Side Outputs. Connect the gates of the Low-Side power MOSFETs to these pins. |

NOTE: x = A, B and C.

Absolute Maximum Ratings

| | |
|--------------------------------|---|
| Supply Voltage, V_{DD} | -0.3V to 16V |
| Logic I/O Voltages | -0.3V to $V_{DD} + 0.3V$ |
| Voltage on xHS | -6V (Transient) to 85V (-40°C to 150°C) |
| Voltage on xHB | $V_{xHS} - 0.3V$ to $V_{xHS} + V_{DD}$ |
| Voltage on xLO | $V_{SS} - 0.3V$ to $V_{DD} + 0.3V$ |
| Voltage on xHO | $V_{xHS} - 0.3V$ to $V_{xHB} + 0.3V$ |
| Phase Slew Rate | 20V/ns |

Thermal Information

| | |
|--|-------------------------------|
| Thermal Resistance (Typical, Note 1) | θ_{JA} (°C/W) |
| SOIC Package | 75 |
| PDIP Package | 70 |
| Maximum Storage Temperature Range | -65°C to 150°C |
| Maximum Junction Temperature | 150°C |
| Maximum Lead Temperature (Soldering 10s) | 300°C (SOIC - Lead Tips Only) |

Operating Conditions

| | |
|----------------------------------|--------------------|
| Supply Voltage, V_{DD} | +7V to +15V |
| Voltage on xHB | $V_{xHS} + V_{DD}$ |
| Voltage on xHS | 0V to 80V |
| Ambient Temperature Range | -40°C to 125°C |
| Junction Temperature Range | -40°C to 150°C |

CAUTION: Stresses above those listed in "Absolute Maximum Ratings" may cause permanent damage to the device. This is a stress only rating and operation of the device at these or any other conditions above those indicated in the operational sections of this specification is not implied.

NOTES:

1. θ_{JA} is measured with the component mounted on an evaluation PC board in free air.
2. All voltages are relative to V_{SS} unless otherwise specified.
3. x = A, B and C. For example, xHS refers to AHS, BHS and CHS.

Electrical Specifications $V_{DD} = V_{xHB} = 12V$, $V_{SS} = V_{xHS} = 0V$, $R_{DEL} = 20K$, $R_{UV} = \infty$, Gate Capacitance (C_{GATE}) = 1000pF

| PARAMETER | TEST CONDITIONS | $T_J = 25^\circ C$ | | | $T_J = -40^\circ C$ TO $150^\circ C$ | | UNITS |
|--|------------------------------------|--------------------|------|------|--------------------------------------|------|---------|
| | | MIN | TYP | MAX | MIN | MAX | |
| SUPPLY CURRENTS AND UNDER VOLTAGE PROTECTION | | | | | | | |
| V_{DD} Quiescent Current | $\overline{xHI} = 5V$, $xLI = 5V$ | 2.7 | 3.4 | 4.2 | 2.1 | 4.3 | mA |
| V_{DD} Operating Current | $f = 20kHz$, 50% Duty Cycle | 6.3 | 8.25 | 10.5 | 5 | 11 | mA |
| xHB On Quiescent Current | $\overline{xHI} = 0V$ | - | 40 | 80 | - | 100 | μA |
| xHB Off Quiescent Current | $\overline{xHI} = V_{DD}$ | 0.6 | 0.8 | 1.3 | 0.5 | 1.4 | mA |
| xHB Operating Current | $f = 20kHz$, 50% Duty Cycle | 0.7 | 0.9 | 1.3 | - | 2.0 | mA |
| Qpump Output Voltage | No Load | 11.5 | 12.5 | 14 | 10.5 | 14.5 | V |
| Qpump Output Current | $V_{xHS} = 12V$, $V_{xHB} = 22V$ | 50 | 100 | 130 | - | 140 | μA |
| xHB, xHS Leakage Current | $V_{xHS} = 80V$, $V_{xHB} = 93V$ | 7 | 24 | 45 | - | 50 | μA |
| V_{DD} Rising Undervoltage Threshold | R_{UV} open | 6.2 | 7.1 | 8.0 | 6.1 | 8.1 | V |
| V_{DD} Falling Undervoltage Threshold | R_{UV} open | 5.75 | 6.6 | 7.5 | 5.6 | 7.6 | V |
| Minimum Undervoltage Threshold | $R_{UV} = V_{DD}$ | 5 | 6.2 | 6.8 | 4.9 | 6.9 | V |
| INPUT PINS: ALI, BLI, CLI, \overline{AHI}, \overline{BHI}, \overline{CHI}, AND DIS | | | | | | | |
| Low Level Input Voltage | | - | - | 1.0 | - | 0.8 | V |
| High Level Input Voltage | | 2.5 | - | - | 2.7 | - | V |
| Input Voltage Hysteresis | | - | 35 | - | - | - | mV |
| Low Level Input Current | $V_{IN} = 0V$ | 60 | 100 | 135 | 55 | 140 | μA |
| High Level Input Current | $V_{IN} = 5V$ | -1 | - | +1 | -10 | +10 | μA |
| GATE DRIVER OUTPUT PINS: ALO, BLO, CLO, AHO, BHO, AND CHO | | | | | | | |
| Low Level Output Voltage ($V_{OUT} - V_{SS}$) | $I_{SINKING} = 30mA$ | - | 100 | - | - | 200 | mV |
| Peak Turn-On Current | $V_{OUT} = 0V$ | 0.3 | 0.5 | 0.7 | - | 1.0 | A |
| Peak Turn-Off Current | $V_{OUT} = 12V$ | 0.7 | 1.1 | 1.5 | 0.5 | 1.7 | A |

HIP4086

Switching Specifications $V_{DD} = V_{xHB} = 12V$, $V_{SS} = V_{xHS} = 0V$, $C_{GATE} = 1000pF$, $R_{DEL} = 10k$

| PARAMETER | TEST CONDITIONS | $T_J = 25^{\circ}C$ | | | $T_J = -40^{\circ}C$ TO $150^{\circ}C$ | | UNITS |
|--|-----------------------------------|---------------------|-----|------|--|-----|---------|
| | | MIN | TYP | MAX | MIN | MAX | |
| TURN-ON DELAY AND PROPAGATION DELAY | | | | | | | |
| Dead Time | $R_{DEL} = 100K$ | 3.8 | 4.5 | 6 | 3 | 7 | μs |
| | $R_{DEL} = 10K$ | 0.38 | 0.5 | 0.65 | 0.3 | 0.7 | μs |
| Dead Time Channel Matching | $R_{DEL} = 10K$ | - | 7 | 15 | - | 20 | % |
| Lower Turn-Off Propagation Delay (xLI-xLO) | No Load | - | 30 | 45 | - | 65 | ns |
| Upper Turn-Off Propagation Delay (xHI-xHO) | No Load | - | 75 | 90 | - | 100 | ns |
| Lower Turn-On Propagation Delay (xLI-xLO) | No Load | - | 45 | 75 | - | 90 | ns |
| Upper Turn-On Propagation Delay (xHI-xHO) | No Load | - | 65 | 90 | - | 100 | ns |
| Rise Time | $C_{GATE} = 1000pF$ | - | 20 | 40 | - | 50 | ns |
| Fall Time | $C_{GATE} = 1000pF$ | - | 10 | 20 | - | 25 | ns |
| Disable Turn-Off Propagation Delay (DIS - Lower Outputs) | | - | 55 | 80 | - | 90 | ns |
| Disable Turn-Off Propagation Delay (DIS - Upper Outputs) | | - | 80 | 90 | - | 100 | ns |
| Disable to Lower Turn-On Propagation Delay (DIS - xLO) | | - | 55 | 80 | - | 100 | ns |
| Disable to Upper Enable (DIS - xHO) | $R_{DEL} = 10K$, C_{RFSH} Open | - | 2.0 | - | - | - | μs |
| Refresh Pulse Width (xLO) | C_{RFSH} Open | - | 1.5 | - | - | - | μs |

Timing Diagrams

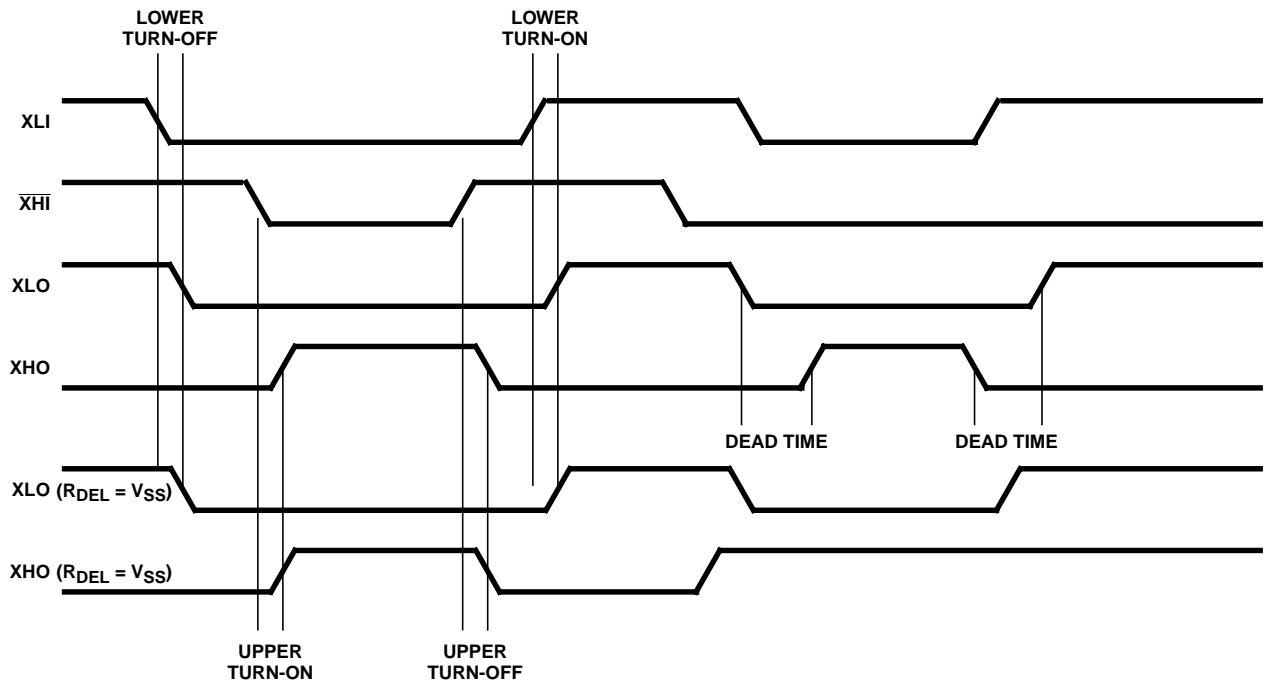

FIGURE 1.

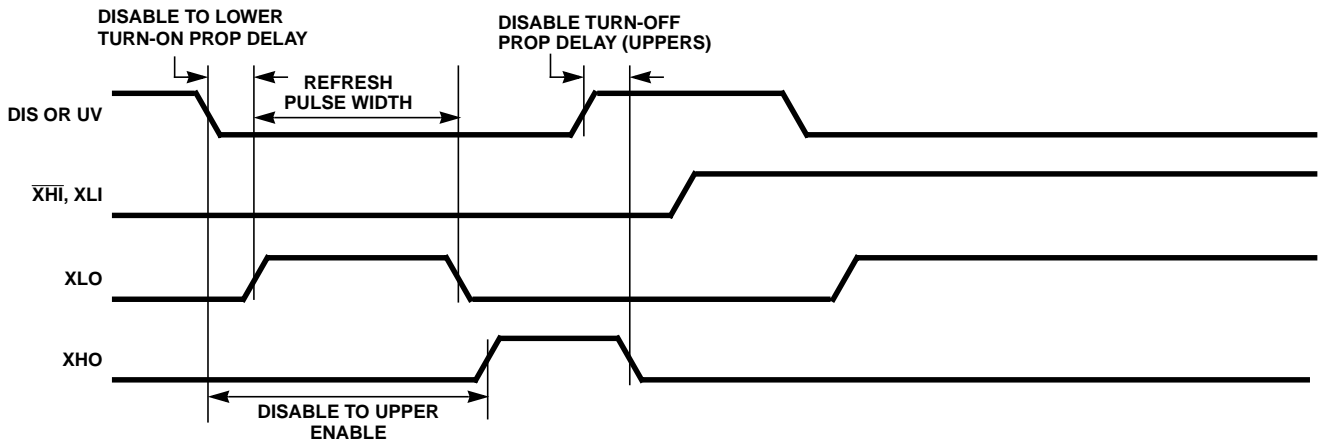

FIGURE 2. DISABLE FUNCTION

NOTES:

4. X means any "A", "B", or "C" phase.
5. With RDEL resistor tied to V_{DD}, lowers and uppers cannot be turned on at the same time. Low side logic overrides high side logic unless RDEL < 100mV.

Typical Performance Curves

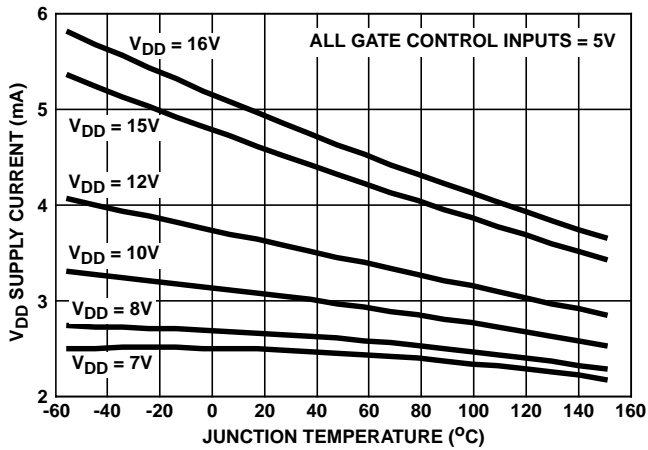

FIGURE 3. V_{DD} SUPPLY CURRENT vs V_{DD} SUPPLY VOLTAGE

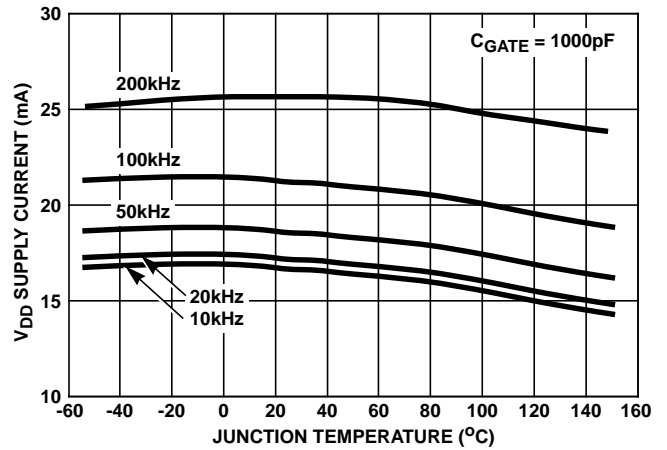

FIGURE 4. V_{DD} SUPPLY CURRENT vs SWITCHING FREQUENCY

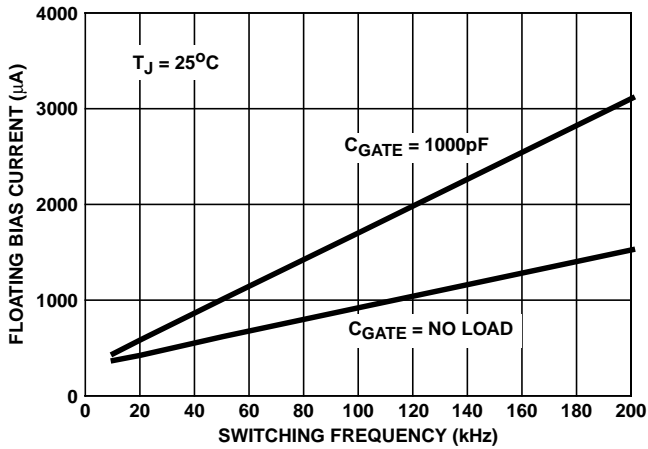

FIGURE 5. FLOATING I_{xHB} BIAS CURRENT

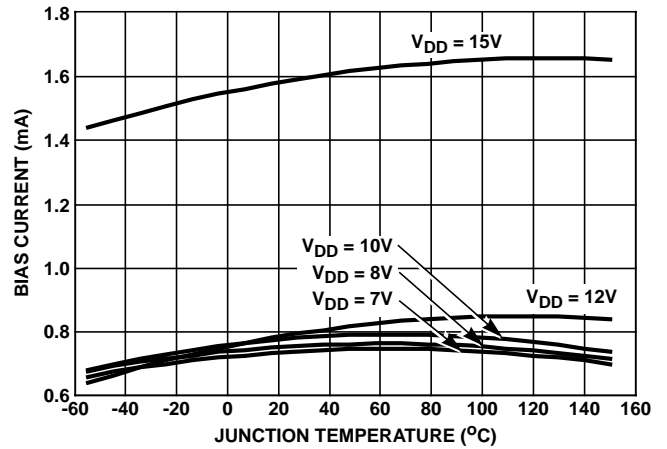

FIGURE 6. OFF-STATE I_{xHB} BIAS CURRENT

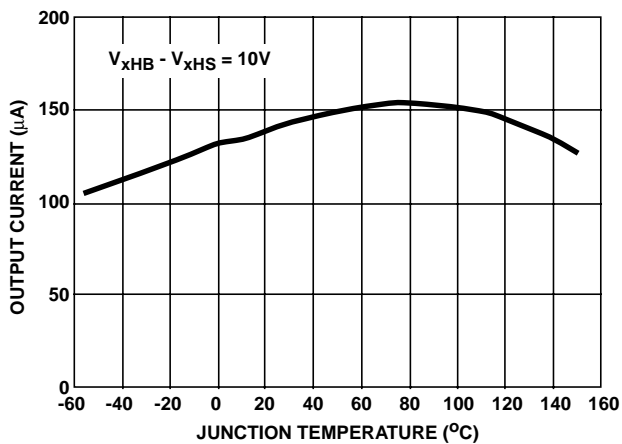

FIGURE 7. CHARGE PUMP OUTPUT CURRENT

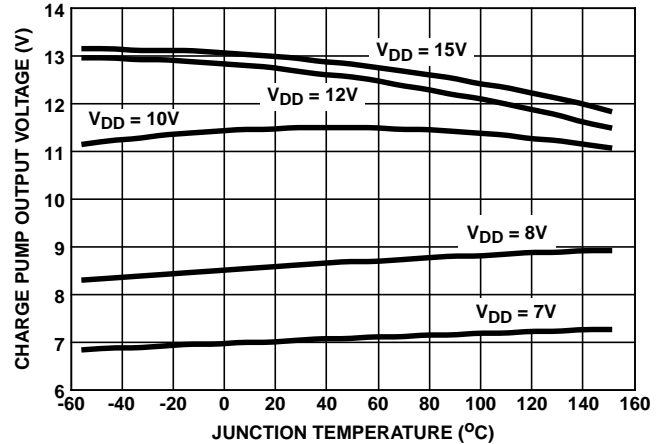

FIGURE 8. CHARGE PUMP OUTPUT VOLTAGE

Typical Performance Curves (Continued)

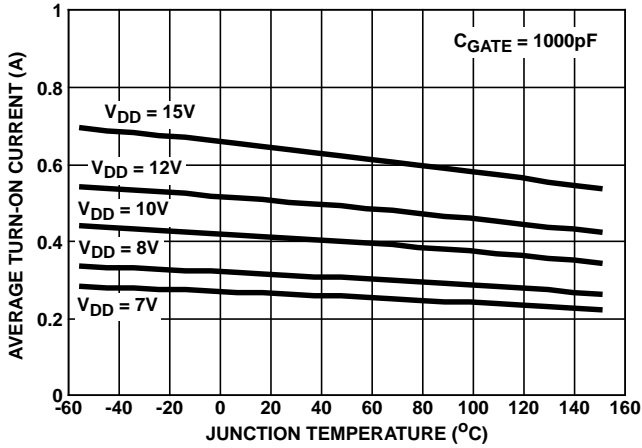

FIGURE 9. AVERAGE TURN-ON CURRENT (0 TO 5V)

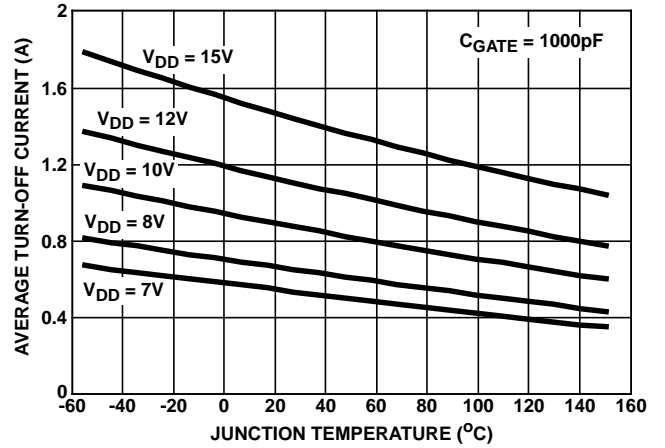

FIGURE 10. AVERAGE TURN-OFF CURRENT (V_{DD} TO 4V)

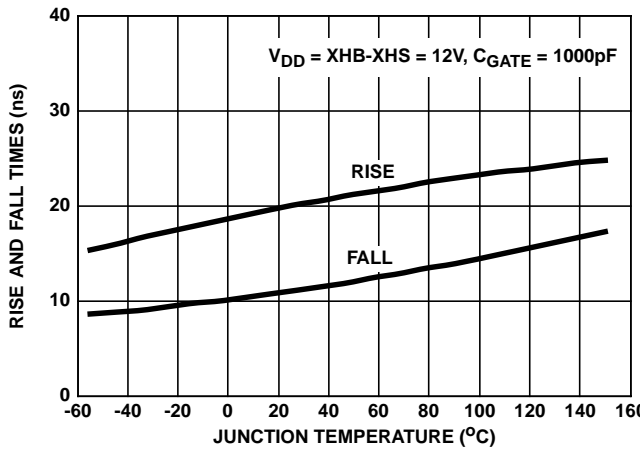

FIGURE 11. RISE AND FALL TIMES (10-90%)

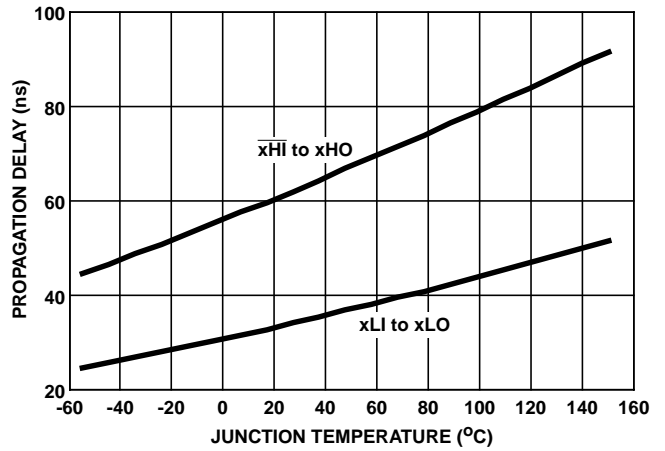

FIGURE 12. PROPAGATION DELAY

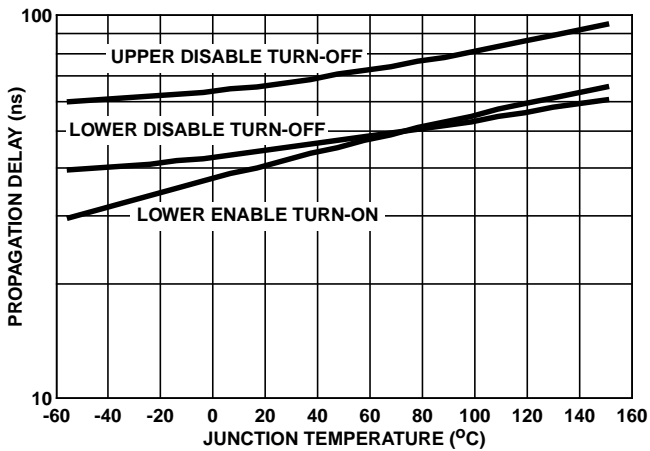

FIGURE 13. DISABLE PIN PROPAGATION DELAY

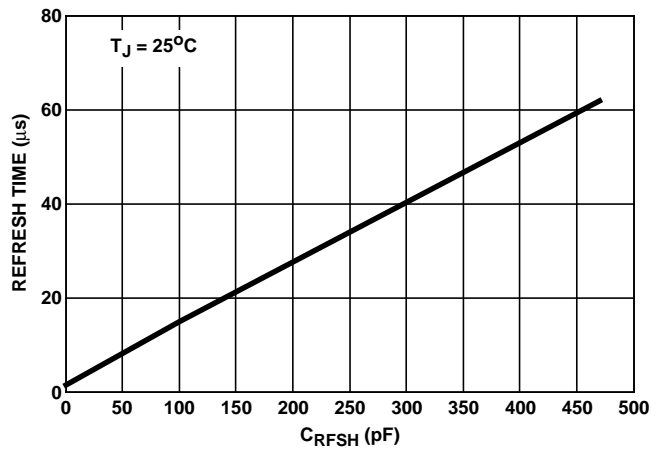

FIGURE 14. REFRESH TIME

Typical Performance Curves (Continued)

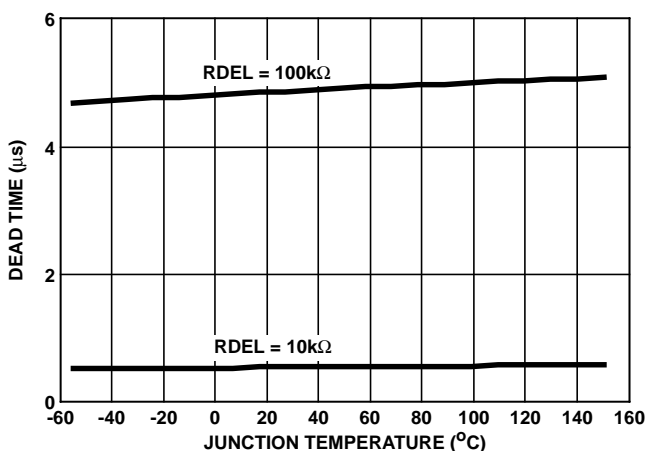

FIGURE 15. DEAD TIME

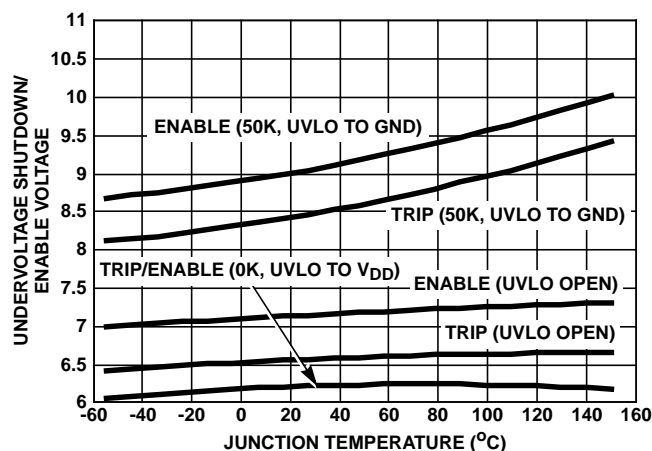

FIGURE 16. UNDERVOLTAGE THRESHOLD

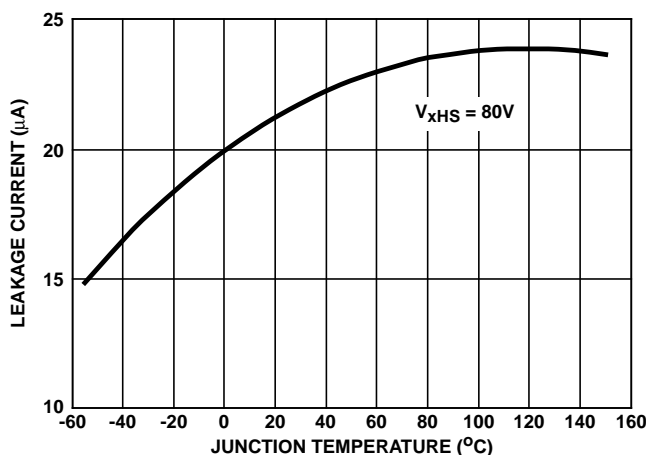

FIGURE 17. I_{xHS} LEAKAGE CURRENT

All Intersil semiconductor products are manufactured, assembled and tested under ISO9000 quality systems certification.

Intersil semiconductor products are sold by description only. Intersil Corporation reserves the right to make changes in circuit design and/or specifications at any time without notice. Accordingly, the reader is cautioned to verify that data sheets are current before placing orders. Information furnished by Intersil is believed to be accurate and reliable. However, no responsibility is assumed by Intersil or its subsidiaries for its use; nor for any infringements of patents or other rights of third parties which may result from its use. No license is granted by implication or otherwise under any patent or patent rights of Intersil or its subsidiaries.

For information regarding Intersil Corporation and its products, see web site <http://www.intersil.com>

Sales Office Headquarters

NORTH AMERICA
 Intersil Corporation
 P. O. Box 883, Mail Stop 53-204
 Melbourne, FL 32902
 TEL: 1-800-442-7747
 (407) 727-9207
 FAX: (407) 724-7240

EUROPE
 Intersil SA
 Mercure Center
 100, Rue de la Fusee
 1130 Brussels, Belgium
 TEL: (32) 2.724.2111
 FAX: (32) 2.724.22.05

ASIA
 Intersil (Taiwan) Ltd.
 7F-6, No. 101 Fu Hsing North Road
 Taipei, Taiwan
 Republic of China
 TEL: (886) 2 2716 9310
 FAX: (886) 2 2715 3029