HM6207H Series

256 k High Speed SRAM (256-kword × 1-bit)

HITACHI

Features

- Single 5 V supply and high density 24-pin package
- High speed
Access time: 25/35/45 ns (max)
- Low power
 - Operation: 300 mW (typ)
 - Standby: 100 μ W (typ)
30 μ W (typ) (L-version)
- Completely static memory required, no clock or timing strobe required
- Equal access and cycle time
- Directly TTL compatible, all inputs and outputs
- Battery backup operation capability (L-version)

Ordering Information

Type No.	Access Time	Package
HM6207HP-25	25 ns	300-mil 24-pin plastic DIP (DP-24NC)
HM6207HP-35	35 ns	
HM6207HP-45	45 ns	
HM6207HLP-25	25 ns	300-mil 24-pin SOJ (CP-24D)
HM6207HLP-35	35 ns	
HM6207HLP-45	45 ns	
HM6207HJP-25	25 ns	300-mil 24-pin SOJ (CP-24D)
HM6207HJP-35	35 ns	
HM6207HJP-45	45 ns	
HM6207HLJP-25	25 ns	300-mil 24-pin SOJ (CP-24D)
HM6207HLJP-35	35 ns	
HM6207HLJP-45	45 ns	

Pin Arrangement

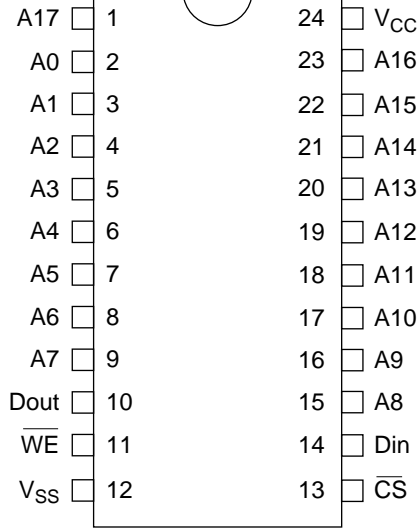

(Top view)

Pin Description

Pin Name	Function
A0–A17	Address
Din	Data input
Dout	Data output
\overline{CS}	Chip select
\overline{WE}	Write enable
V _{cc}	Power supply
V _{ss}	Ground

Block Diagram

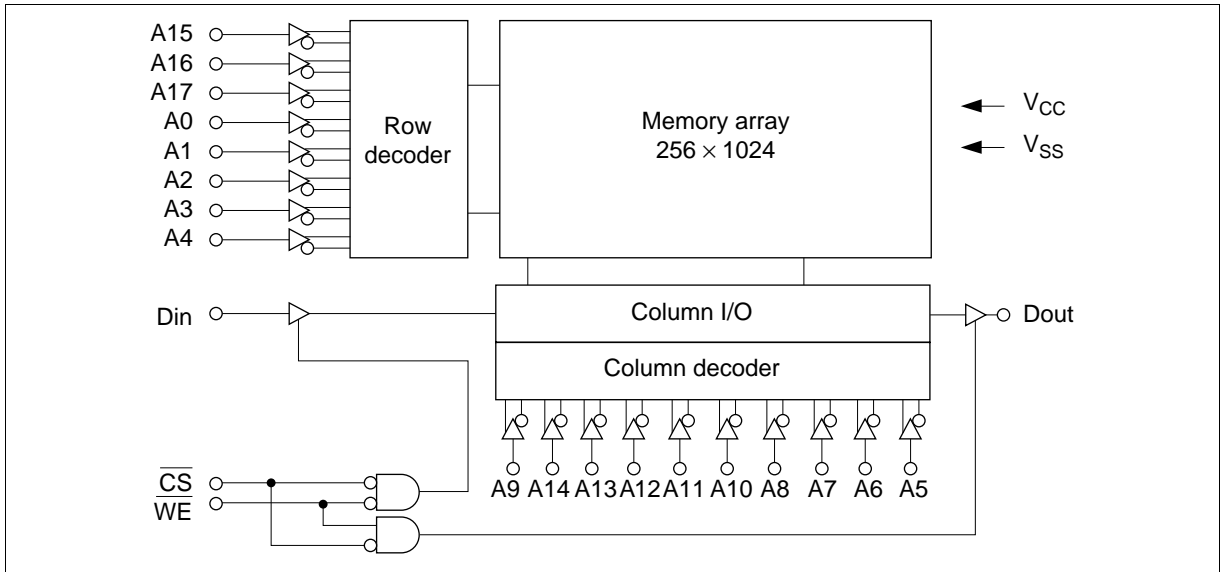

Function Table

\overline{CS}	\overline{WE}	Mode	V_{CC} Current	I/O Pin	Ref. Cycle
H	×	Not selected	I_{SB} , I_{SB1}	High-Z	—
L	H	Read	I_{CC}	Dout	Read cycle
L	L	Write	I_{CC}	High-Z	Write cycle

Note: × = Don't care.

Absolute Maximum Ratings

Parameter	Symbol	Value	Unit
Voltage on any pin relative to V_{SS}	V_{in}	-0.5 ¹ to +7.0	V
Power dissipation	P_T	1.0	W
Operating temperature range	T_{opr}	0 to +70	°C
Storage temperature range	T_{stg}	-55 to +125	°C
Storage temperature range under bias	T_{bias}	-10 to +85	°C

Note: 1. $V_{in\ min} = -2.5\ V$ for pulse width < 10 ns.

HM6207H Series

Recommended DC Operating Conditions (Ta = 0 to +70°C)

Parameter	Symbol	Min	Typ	Max	Unit
Supply voltage	V_{CC}	4.5	5.0	5.5	V
	V_{SS}	0	0	0	V
Input high (logic 1) voltage	V_{IH}	2.2	—	6.0	V
Input low (logic 0) voltage	V_{IL}	-0.5 [†]	—	0.8	V

Note: 1. V_{IL} min = -2.0 V for pulse width ≤ 10 ns.

DC Characteristics (Ta = 0 to +70°C, $V_{CC} = 5\text{ V} \pm 10\%$, $V_{SS} = 0\text{ V}$)

Parameter	Symbol	HM6207H-25		HM6207H-35/45		Unit	Test Conditions	
		Min	Typ [†]	Min	Typ [†]			
Input leakage current	I_{LI}	—	—	2.0	—	2.0	μA $V_{CC} = \text{Max}$, $V_{in} = V_{SS}$ to V_{CC}	
Output leakage current	I_{LO}	—	—	10.0	—	10.0	μA $\overline{CS} = V_{IH}$, $V_{I/O} = V_{SS}$ to V_{CC}	
Operating power supply current	I_{CC}	—	60	120	—	50	100	mA $\overline{CS} = V_{IL}$, $I_{I/O} = 0\text{ mA}$, min cycle, duty = 100%
	I_{CC1}	—	40	80	—	40	80	mA $\overline{CS} = V_{IL}$, $I_{I/O} = 0\text{ mA}$, t cycle = 50 ns, duty = 100%
Standby power supply current	I_{SB}	—	20	40	—	15	30	mA $\overline{CS} = V_{IH}$, min cycle
Standby power supply current (1)	I_{SB1}	—	0.02	2.0	—	0.02	2.0	mA $\overline{CS} \geq V_{CC} - 0.2\text{ V}$, $0\text{ V} \leq V_{in} < 0.2$, or $V_{in} \geq V_{CC} - 0.2\text{ V}$
	L- Version	—	0.006	0.1	—	0.006	0.1	
Output low voltage	V_{OL}	—	—	0.4	—	—	0.4	V $I_{OL} = 8\text{ mA}$
Output high voltage	V_{OH}	2.4	—	—	2.4	—	—	V $I_{OH} = -4.0\text{ mA}$

Note: 1. Typical values are at $V_{CC} = 5.0\text{ V}$, $T_a = +25^\circ\text{C}$ and not guaranteed.

Capacitance (Ta = 25°C, f = 1 MHz)^{*1}

Parameter	Symbol	Min	Max	Unit	Test Conditions
Input capacitance	C_{in}	—	6	pF	$V_{in} = 0\text{ V}$
Output capacitance	C_{out}	—	10	pF	$V_{out} = 0\text{ V}$

Note: 1. This parameter is sampled and is not 100% tested.

AC Characteristics ($T_a = 0$ to $+70^\circ\text{C}$, $V_{CC} = 5\text{ V} \pm 10\%$ unless otherwise noted)

Test Conditions

- Input pulse levels: V_{SS} to 3.0 V
- Input and output timing reference levels: 1.5 V
- Input rise and fall time: 5 ns
- Output load: See figures

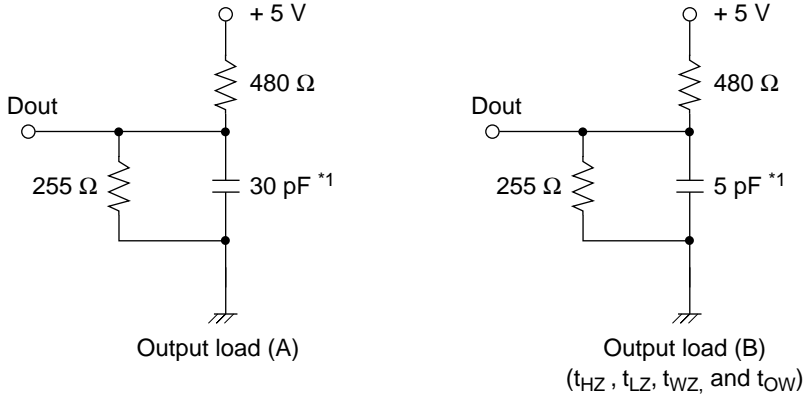

Note: 1. Including scope and jig

Read Cycle

Parameter	Symbol	HM6207H-25		HM6207H-35		HM6207H-45		Unit
		Min	Max	Min	Max	Min	Max	
Read cycle time	t_{RC}	25	—	35	—	45	—	ns
Address access time	t_{AA}	—	25	—	35	—	45	ns
Chip select access time	t_{ACS}	—	25	—	35	—	45	ns
Output hold from address change	t_{OH}	5	—	5	—	5	—	ns
Chip selection to output in low-Z	t_{LZ}^{-1}	5	—	5	—	5	—	ns
Chip deselection to output in high-Z	t_{HZ}^{-1}	0	15	0	20	0	20	ns

Note: 1. Transition is measured ± 200 mV from steady-state voltage with Load (B).

These parameters are sampled and not 100% tested.

Read Timing Waveform (1)

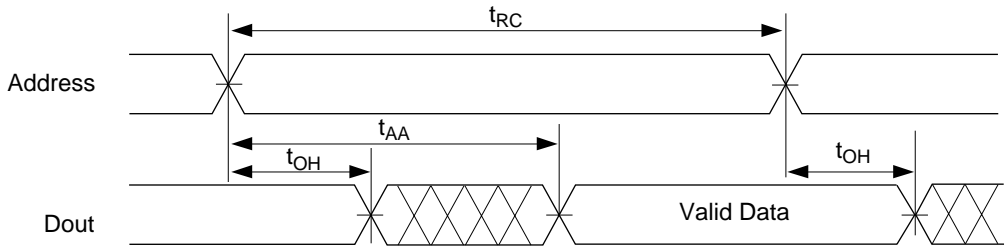

- Notes: 1. \overline{WE} is high for read cycle.
2. Device is continuously selected, $\overline{CS} = V_{IL}$.

Read Timing Waveform (2)

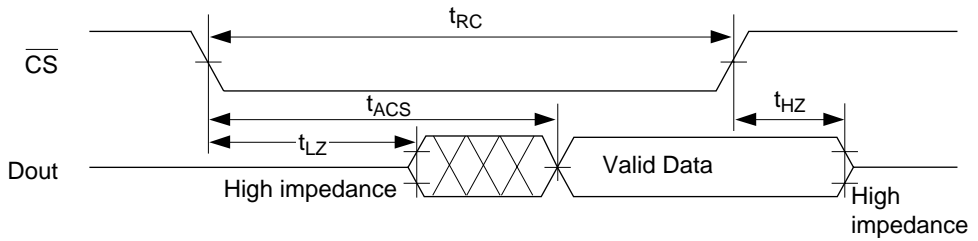

- Notes: 1. \overline{WE} is high for read cycle.
2. Address valid prior to coincident with \overline{CS} transition low.

Write Cycle

Parameter	Symbol	HM6207H-25		HM6207H-35		HM6207H-45		Unit
		Min	Max	Min	Max	Min	Max	
Write cycle time	t_{WC}	25	—	35	—	45	—	ns
Chip selection to end of write	t_{CW}	20	—	30	—	40	—	ns
Address valid to end of write	t_{AW}	20	—	30	—	40	—	ns
Address setup time	t_{AS}	0	—	0	—	0	—	ns
Write pulse width	t_{WP}	20	—	25	—	25	—	ns
Write recovery time	t_{WR}	3	—	3	—	3	—	ns
Data valid to end of write	t_{DW}	15	—	20	—	20	—	ns
Data hold time	t_{DH}	0	—	0	—	0	—	ns
Write enabled to output in high-Z	t_{WZ}^{*1}	0	15	0	20	0	25	ns
Output active from end of write	t_{OW}^{*1}	0	—	0	—	0	—	ns

Note: 1. Transition is measured ± 200 mV from high-impedance voltage with Load (B).
 This parameter is sampled and is not 100% tested.

Write Timing Waveform (1) (\overline{WE} Controlled)

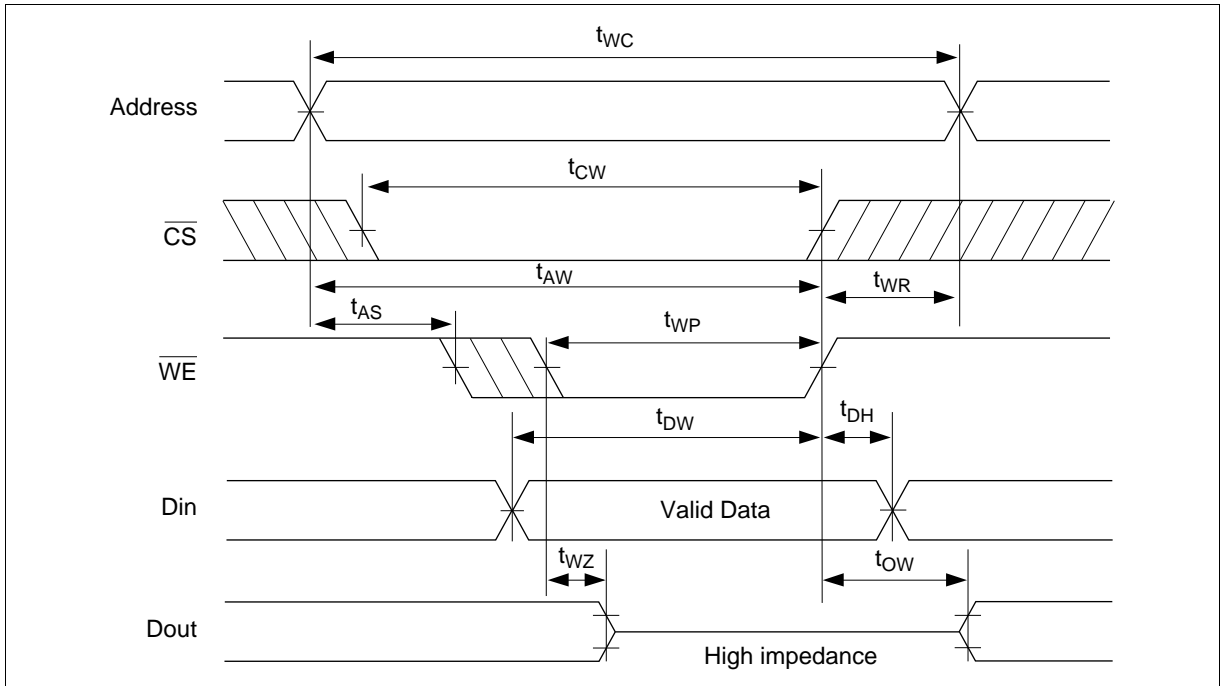

HM6207H Series

Write Timing Waveform (2) (\overline{CE} Controlled)

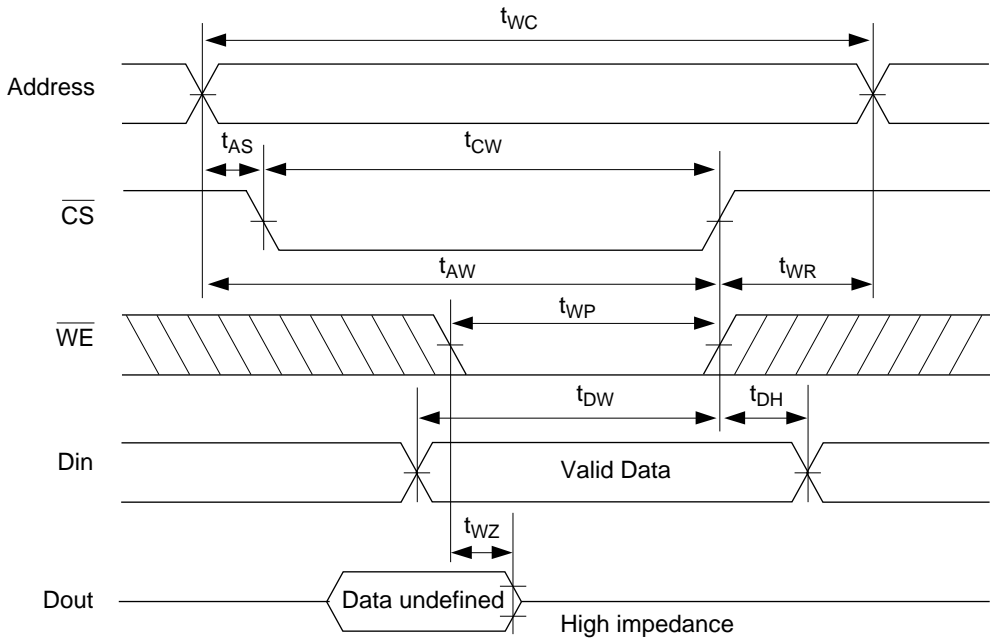

- Notes:
1. A write occurs during the overlap of a low \overline{CS} and a low \overline{WE} .
 2. t_{WR} is measured from the earlier of \overline{CS} or \overline{WE} going high to the end of the write cycle.
 3. If the \overline{CS} low transition occurs simultaneously with the \overline{WE} low transition, the output buffers remain in a high impedance state.
 4. D_{out} has the same phase as write data in this write cycle, if t_{WR} is long enough.

Low V_{CC} Data Retention Characteristics ($T_a = 0$ to $+70^\circ\text{C}$)

These characteristics are guaranteed for the L-version only.

Parameter	Symbol	Min	Typ	Max	Unit	Test Conditions
V_{CC} for data retention	V_{DR}	2.0	—	—	V	$\overline{CS} \geq V_{CC} - 0.2 \text{ V}$, $V_{in} \geq V_{CC} - 0.2 \text{ V}$, or $0 \text{ V} \leq V_{in} \leq 0.2 \text{ V}$
Data retention current	I_{CCDR}	—	2	50^{-1}	μA	
Chip deselect to data retention time	t_{CDR}	0	—	—	ns	
Operation recovery time	t_R	5	—	—	ms	

Note: 1. $V_{CC} = 3.0 \text{ V}$

Low V_{CC} Data Retention Timing Waveform

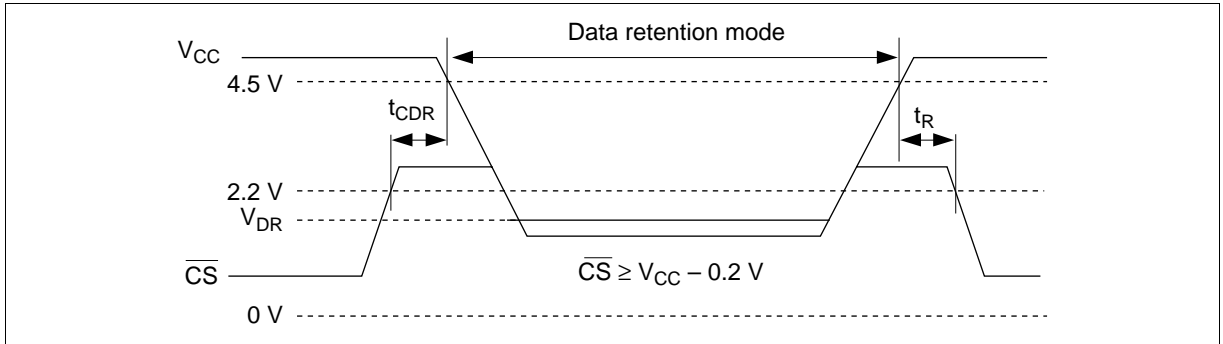

HM6207H Series

Package Dimensions

HM6207HP/HLP Series (DP-24NC)

Unit: mm

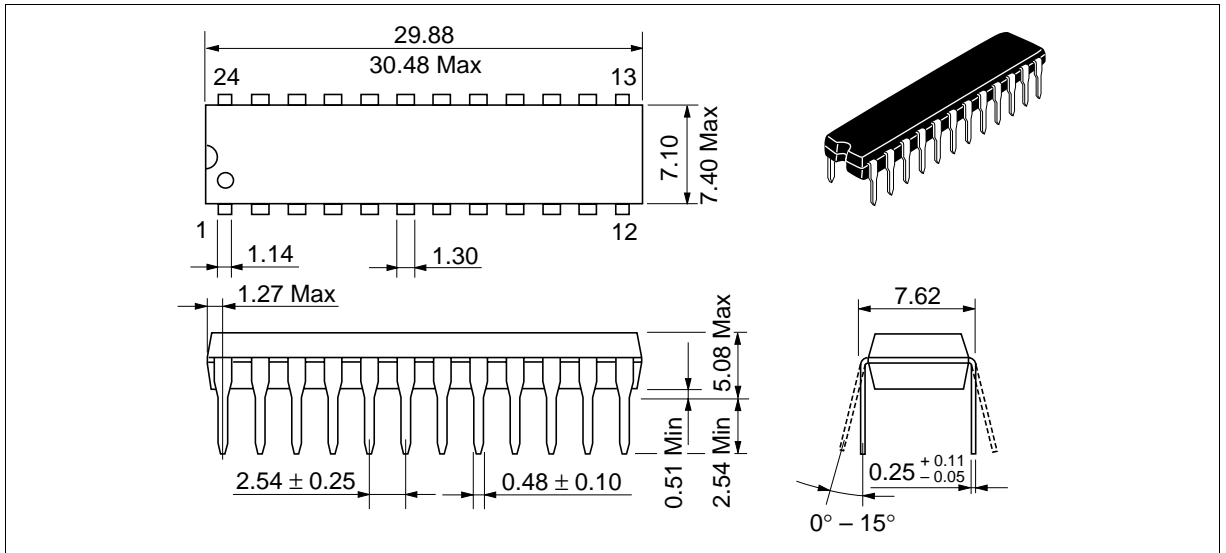

HM6207HJP/HLJP Series (CP-24D)

Unit: mm

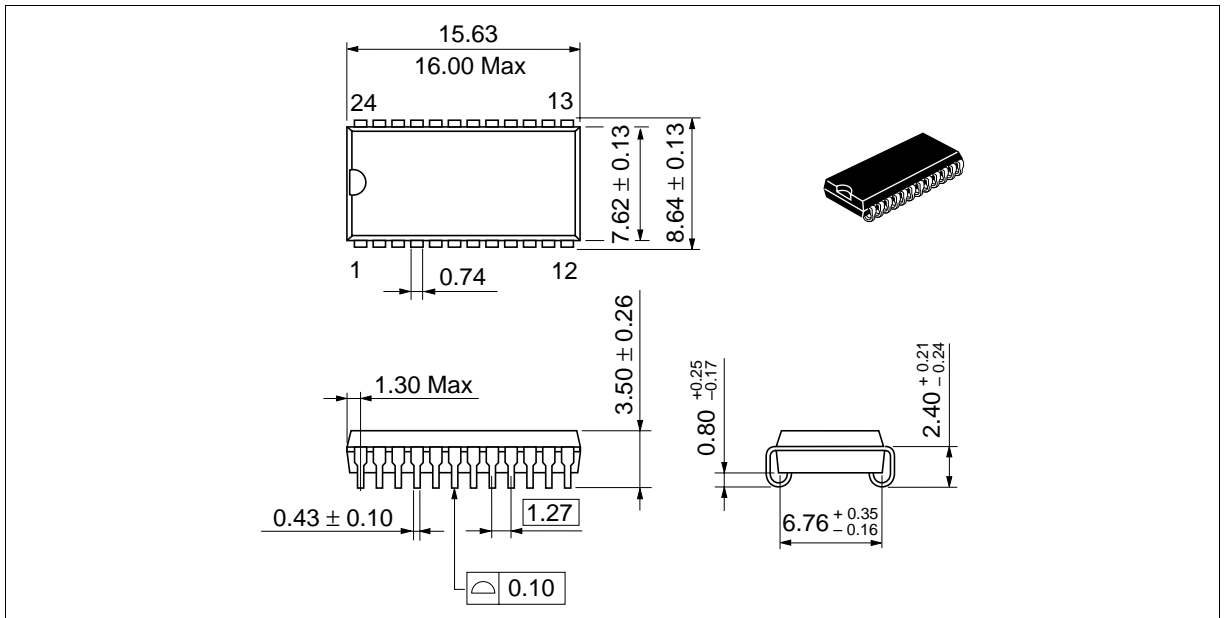

When using this document, keep the following in mind:

1. This document may, wholly or partially, be subject to change without notice.
2. All rights are reserved: No one is permitted to reproduce or duplicate, in any form, the whole or part of this document without Hitachi's permission.
3. Hitachi will not be held responsible for any damage to the user that may result from accidents or any other reasons during operation of the user's unit according to this document.
4. Circuitry and other examples described herein are meant merely to indicate the characteristics and performance of Hitachi's semiconductor products. Hitachi assumes no responsibility for any intellectual property claims or other problems that may result from applications based on the examples described herein.
5. No license is granted by implication or otherwise under any patents or other rights of any third party or Hitachi, Ltd.
6. **MEDICAL APPLICATIONS:** Hitachi's products are not authorized for use in **MEDICAL APPLICATIONS** without the written consent of the appropriate officer of Hitachi's sales company. Such use includes, but is not limited to, use in life support systems. Buyers of Hitachi's products are requested to notify the relevant Hitachi sales offices when planning to use the products in **MEDICAL APPLICATIONS**.

HITACHI

Hitachi, Ltd.

Semiconductor & IC Div.

Nippon Bldg., 2-6-2, Ohte-machi, Chiyoda-ku, Tokyo 100, Japan

Tel: Tokyo (03) 3270-2111

Fax: (03) 3270-5109

For further information write to:

Hitachi America, Ltd.

Semiconductor & IC Div.

2000 Sierra Point Parkway

Brisbane, CA. 94005-1835

U S A

Tel: 415-589-8300

Fax: 415-583-4207

Hitachi Europe GmbH

Electronic Components Group

Continental Europe

Dornacher Straße 3

D-85622 Feldkirchen

München

Tel: 089-9 91 80-0

Fax: 089-9 29 30 00

Hitachi Europe Ltd.

Electronic Components Div.

Northern Europe Headquarters

Whitebrook Park

Lower Cookham Road

Maidenhead

Berkshire SL6 8YA

United Kingdom

Tel: 0628-585000

Fax: 0628-778322

Hitachi Asia Pte. Ltd.

16 Collyer Quay #20-00

Hitachi Tower

Singapore 0104

Tel: 535-2100

Fax: 535-1533

Hitachi Asia (Hong Kong) Ltd.

Unit 706, North Tower,

World Finance Centre,

Harbour City, Canton Road

Tsim Sha Tsui, Kowloon

Hong Kong

Tel: 27359218

Fax: 27306071