

2K × 8 Very Low Power CMOS SRAM

Description

The HM 65162 is a very low power CMOS static RAM organized as 2048 × 8 bits. It is manufactured using the MHS high performance CMOS technology.

The HM 65162 is a "Pure CMOS SRAM" utilising an array of six transistor (6T) memory cells permitting the lowest possible standby supply current (typical value = 0.1 μA) over the full temperature range. The high stability of the 6T cell provides excellent protection against soft errors due to noise.

Easy memory expansion is provided by an active low chip select (\overline{CS}), an active low output enable (\overline{OE}) and three state drivers.

All inputs and outputs of the HM-65162 are TTL compatible and operate from single 5 V supply thus simplifying system design.

The HM 65162 is 100 % processed following the test methods of MIL STD 883C and/or ESA/SCC 9000, making it ideally suitable for military/space applications that demand superior levels of performance and reliability.

Features

- Access Time
 - Commercial : 70 ns (max)
 - Automotive/Military/Industrial : 70/85 ns (max)
- Very Low Power Consumption
 - Active : 240 mW (typ)
 - Standby : 2.0 μW (typ)
 - Data Retention : 0.8 μW (typ)
- Wide Temperature Range : -55 to +125°C
- 600 Mils Width Package
- TTL Compatible Inputs and Outputs
- Asynchronous
- Single 5 Volt Supply
- Equal Cycle and Access Time
- Gated Inputs : No Pull-up/Down Resistors Are Required

Interface

Block Diagram

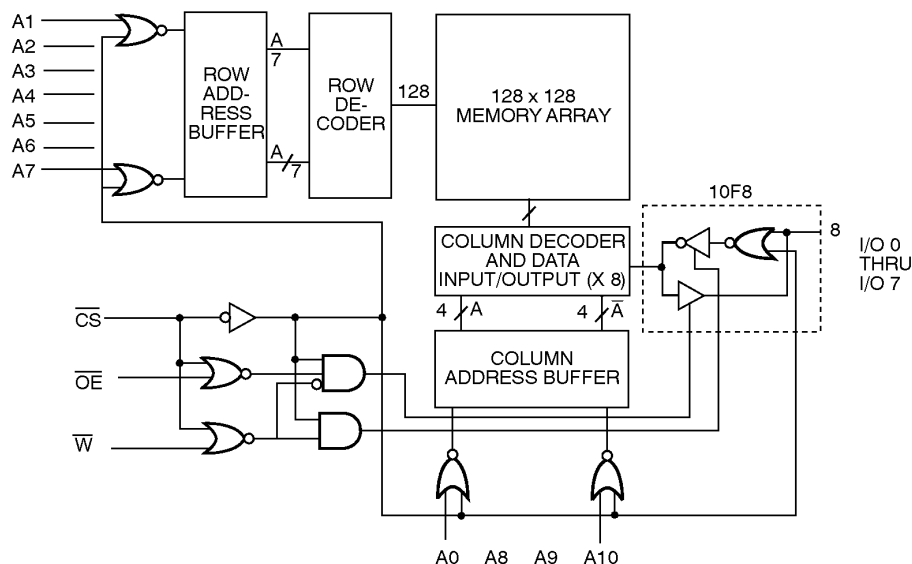

Electrical Characteristics

Absolute Maximum Ratings

Supply voltage to GND potential : -0.5 V to + 7.0 V Storage temperature : -65°C to + 150°C
 Input or Output voltage applied : (Gnd - 0.3 V) to (Vcc + 0.3 V)

Operating Range

	OPERATING VOLTAGE	OPERATING TEMPERATURE
Military (- 2)	$V_{CC} \pm 10\%$	- 55°C to + 125°C
Automotive (- A)	$V_{CC} \pm 10\%$	- 40°C to + 125°C
Industrial (- 9)	$V_{CC} \pm 10\%$	- 40°C to + 85°C
Commercial (- 5)	$V_{CC} \pm 10\%$	0°C to 70°C

Recommended DC Operating Conditions

PARAMETER	DESCRIPTION	MINIMUM	TYPICAL	MAXIMUM	UNIT
V_{CC}	Supply voltage	4.5	5.0	5.5	V
Gnd	Ground	0.0	0.0	0.0	V
VIL (1)	Input low voltage	- 0.3	0.0	0.8	V
VIH	Input high voltage	2.2	-	$V_{CC} + 0.3\text{ V}$	V

Note : 1. VIL min = -0.3 V or -1.0 V pulse width 50 ns.

Capacitance

PARAMETER	DESCRIPTION	MINIMUM	TYPICAL	MAXIMUM	UNIT
Cin (2)	Input capacitance	-	-	5	pF
Cout (2)	Output capacitance	-	-	7	pF

Note : 2. TA = 25°C, f = 1 MHz, Vcc = 5.0 V, these parameters are not 100 % tested.

DC Parameters

PARAMETER	DESCRIPTION	MINIMUM	TYPICAL	MAXIMUM	UNIT
IIX (3)	Input leakage current	- 1.0	-	1.0	μA
IOZ (3)	Output leakage current	- 1.0	-	1.0	μA
VOL (4)	Output low voltage	-	-	0.4	V
VOH (4)	Output high voltage	2.4	-	-	V

Note : 3. Gnd < Vin < Vcc, Gnd < Vout < Vcc Output disabled.
 4. Vcc min, IOL = 4.0 mA, IOH = -1.0 mA.

HM 65162

Consumption for Commercial (-5) Specification

SYMBOL	PARAMETER	65162 -5	65162C-5	UNIT	VALUE
ICCSB (5)	Standby supply current	2.0	2.0	mA	max
ICCSB1 (6)	Standby supply current	1.0	100.0	μA	max
ICC (7)	Operating supply current	70.0	70.0	mA	max
ICCOP (8)	Operating supply current	70.0	70.0	mA	max

Consumption for Industrial (-9) Specification

SYMBOL	PARAMETER	65162 B-9	65162 -9	65162 C-9	UNIT	VALUE
ICCSB (5)	Standby supply current	3.0	3.0	3.0	mA	max
ICCSB1 (6)	Standby supply current	5.0	5.0	100.0	μA	max
ICC (7)	Operating supply current	70.0	70.0	70.0	mA	max
ICCOP (8)	Dynamic operating current	70.0	70.0	70.0	mA	max

Consumption for Automotive (-A) & Military (-2) Specifications

SYMBOL	PARAMETER	65162 B-2	65162 -2	65162 C-2	UNIT	VALUE
ICCSB (5)	Standby supply current	5.0	5.0	5.0	mA	max
ICCSB1 (6)	Standby supply current	50.0	50.0	500.0	μA	max
ICC (7)	Operating supply current	70.0	70.0	70.0	mA	max
ICCOP (8)	Operating supply current	70.0	70.0	70.0	mA	max

- Notes :
5. $\overline{CS} \geq V_{IH}$.
 6. $\overline{CS} \geq V_{cc} - 0.3 \text{ V}$, $I_{out} = 0 \text{ mA}$.
 7. $\overline{CS} \leq V_{IL}$, $I_{out} = 0 \text{ mA}$, $V_{in} = \text{Gnd}/V_{cc}$.
 8. $V_{cc} \text{ max}$, $I_{out} = 0 \text{ mA}$, $f = 1 \text{ MHz}$ and 5 mA/MHz , $V_{in} = \text{Gnd}/V_{cc}$.

Data Retention Mode

MHS CMOS RAM's are designed with battery backup in mind. Data retention voltage and supply current are guaranteed over temperature. The following rules insure data retention :

1. Chip select (\overline{CS}) must be held high during data retention ; within V_{CC} to $V_{CC} - 0.2$ V.
2. Output Enable (\overline{OE}) should be held high to keep the RAM outputs high impedance, minimizing power dissipation.

3. \overline{CS} and \overline{OE} must be kept between $V_{CC} + 0.3$ V and 70 % of V_{CC} during the power up and power down transitions.
4. The RAM can begin operation > 55 ns after V_{CC} reaches the minimum operating voltage (4.5 V).

Timing

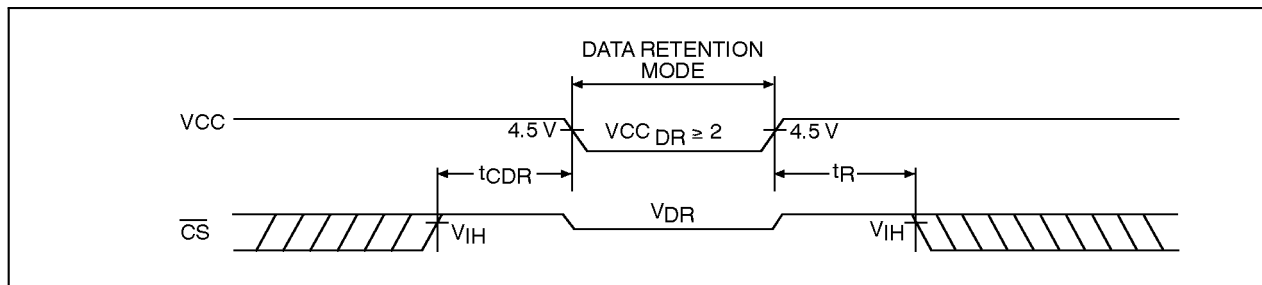

Data Retention Characteristics

PARAMETER	DESCRIPTION	MINIMUM	TYPICAL (9)	MAXIMUM	UNIT
VCCDR	Vcc for data retention	2.0	-	-	V
TCDR	Chip deselect to data retention time	0.0	-	-	ns
TR	Operation recovery time	TAVAV (10)	-	-	ns
ICCDR1(11)	Data retention current				
	2.0 V HM-65162B-9	-	0.1	2.0	μ A
	HM-65162B-2/-A	-	0.1	20.0	μ A
	HM-65162C-5	-	0.1	30.0	μ A
	HM-65162C-9	-	0.1	30.0	μ A
ICCDR2(11)	Data retention current				
	3.0 V HM-65162B-9	-	0.3	3.0	μ A
	HM-65162B-2/-A	-	0.3	30.0	μ A
	HM-65162C-5	-	0.3	50.0	μ A
	HM-65162C-9	-	0.3	50.0	μ A
	HM-65162C-2/-A	-	0.3	300.0	μ A

- Notes :
9. $T_A = 25^\circ\text{C}$.
 10. TAVAV = Read cycle time.
 11. $\overline{CS} = V_{CC}$, $V_{in} = Gnd/V_{CC}$, this parameter is only tested to $V_{CC} = 2$ V.

HM 65162

AC Parameters

AC Conditions :

Input pulse levels : Gnd to 3.0 V Input rise : 5 ns
 Input timing reference levels : 1.5 V Output load : 1 TTL gate + 100 pF

Write Cycle : Commercial (-5) Specification

SYMBOL	PARAMETER	65162-5	65162C-5	UNIT	VALUE
TAVAV	Write cycle time	70	70	ns	min
TAVWL	Address set-up time	0	0	ns	min
TAVWH	Address valid to end of write	50	50	ns	min
TDVWH	Data set-up time	30	30	ns	min
TELWH	\overline{CS} low to write end	45	45	ns	min
TWLQZ(12)	Write low to high Z	40	40	ns	max
TWLWH	Write pulse width	40	40	ns	min
TWHAX	Address hold to end of write	10	10	ns	min
TWHDX	Data hold time	10	10	ns	min
TWHQX (12)	Write high to low Z	0	0	ns	min

Write Cycle : Industrial (-9), Automotive (-A) and Military (-2) Specifications

SYMBOL	PARAMETER	65162 B-9/2/A	65162 -9/2/A	65162 C-9/2/A	UNIT	VALUE
TAVAV	Write cycle time	70	85	85	ns	min
TAVWL	Address set-up time	0	0	0	ns	min
TAVWH	Address valid to end of write	50	65	65	ns	min
TDVWH	Data set-up time	30	30	30	ns	min
TELWH	\overline{CS} low to write end	45	55	55	ns	min
TWLQZ(12)	Write low to high Z	40	50	50	ns	max
TWLWH	Write pulse width	40	55	55	ns	min
TWHAX	Address hold to end of write	10	10	10	ns	min
TWHDX	Data hold time	10	10	10	ns	min
TWHQX (12)	Write high to low Z	0	0	0	ns	min

Note : 12. The data input set-up and hold timing should be referenced to the rising edge of the signal that terminates the write.

Write Cycle 1 (\overline{W} Controlled) (note 13)

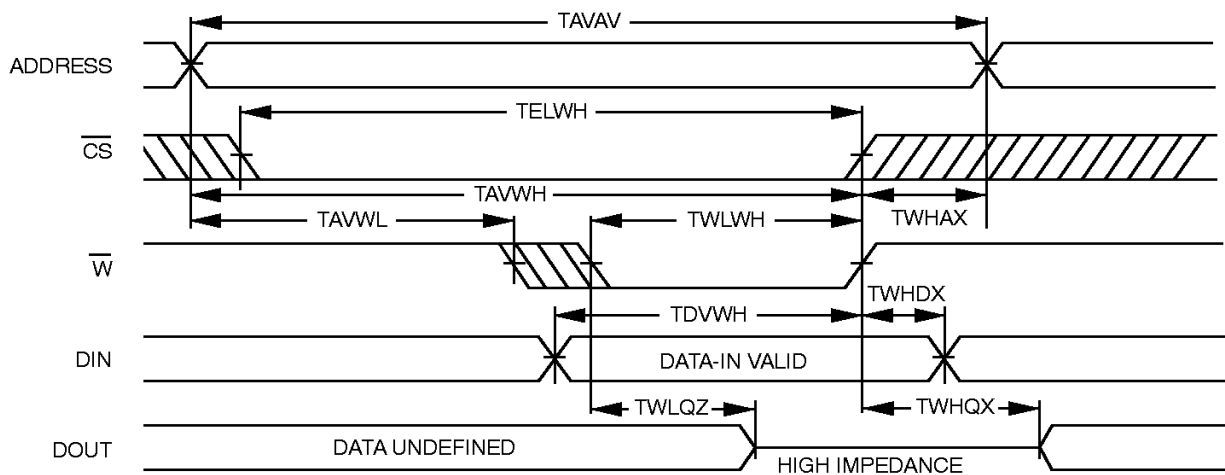

Write Cycle 2 (\overline{CS} Controlled) (note 13)

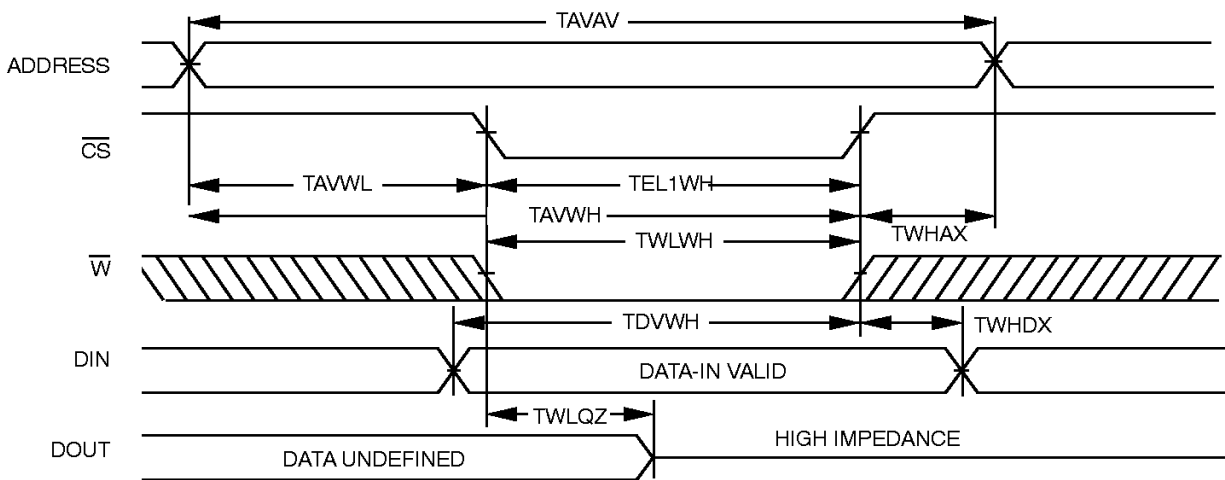

Note : 13. The internal write time of the memory is defined by the overlap of \overline{CS} LOW and \overline{W} LOW. Both signals must be LOW to initiate a write and either signal can terminate a write by going HIGH. The data input setup and hold timing should be referenced to the rising edge of the signal that terminates the write.
Data I/O Pins enter high-impedance state, as shown, when \overline{OE} is held LOW during write.

Read Cycle : Commercial (-5) Specification

SYMBOL	PARAMETER	65162 -5	65162 C-5	UNIT	VALUE
TAVAV	Read cycle time	70	70	ns	min
TAVQV	Address access time	70	70	ns	max
TAVQX	Address valid to low Z	5	5	ns	min
TELQV	Chip-select access time	70	70	ns	max
TELQZ	\overline{CS} low to low Z	5	5	ns	min
TEHQZ	\overline{CS} high to high Z	50	50	ns	max
TGLQV	Output enable access time	50	50	ns	max
TGLQX	\overline{OE} low to low Z	5	5	ns	min
TGHQZ	\overline{OE} high to high Z	40	40	ns	max

Read Cycle : Industrial (-9), Automotive (-A) and Military (-2) Specifications

SYMBOL	PARAMETER	65162 B-9/2/A	65162 -9/2/A	65162 C-9/2/A	UNIT	VALUE
TAVAV	Read cycle time	70	85	85	ns	min
TAVQV	Address access time	70	85	85	ns	max
TAVQX	Address valid to low Z	5	5	5	ns	min
TELQV	Chip-select access time	70	85	85	ns	max
TELQX	\overline{CS} low to low Z	5	5	5	ns	min
TEHQZ	\overline{CS} high to high Z	35	50	50	ns	max
TGLQV	Output Enable access time	50	65	65	ns	max
TGLQX	\overline{OE} low to low Z	5	5	5	ns	min
TGHQZ	\overline{OE} high to high Z	35	40	40	ns	min

Read Cycle

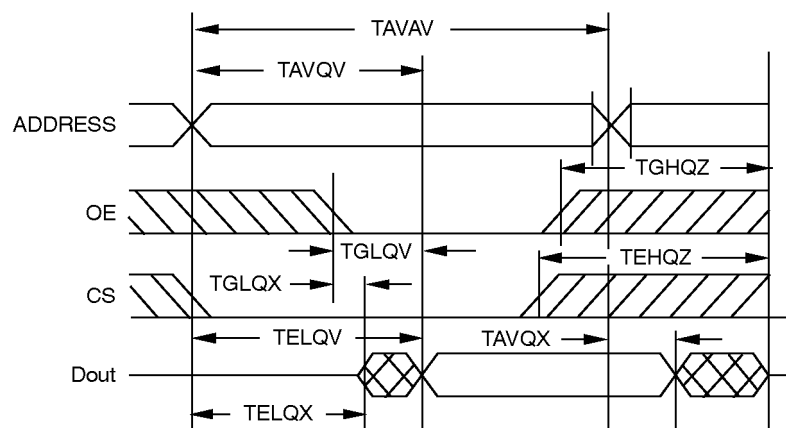

Addresses must remain stable for the duration of the read cycle. To read \overline{OE} and \overline{CS} must be $< V_{IL}$ and $\overline{W} > V_{IH}$. The output buffers can be controlled independently by \overline{OE} while \overline{CS} is low. To execute consecutive read cycles, \overline{CS}

may be tied low continuously until all desired locations are accessed. When \overline{CS} is low, addresses must be driven by stable logic levels and must not be in the high impedance state.

Burn-in Schematics

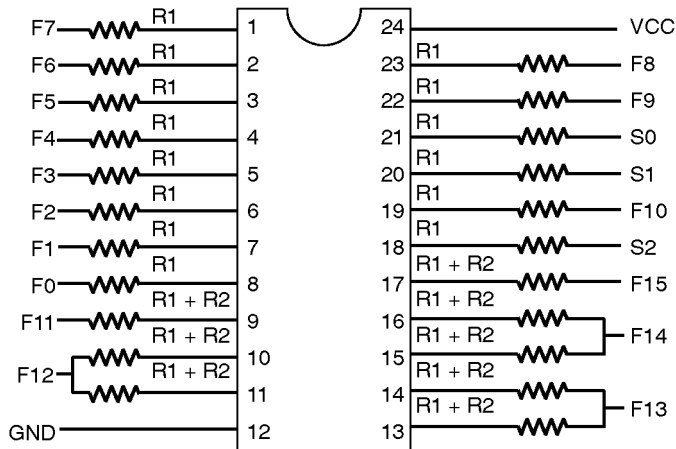

$R1 = 1\text{ K}\Omega$
 $R2 = 2.2\text{ K}\Omega$
 $Fo = 25\text{ KHz} \pm 20\%$
 $Fn = 1/2 F n - 1$
 $S0, S1, S2$: programmable signals
 for write / read cycles
 $VCC = 5.5\text{ V}$

Ordering Information

PACKAGE		DEVICE TYPE	GRADE	LEVEL
HM	3	65162	B	-5 : R
0 - Chip form		2 k × 8 very low power static RAM		-A : Automotive
1 - Ceramic 24 pins 600 mils				-2 : Military
3 - Plastic 24 pins 600 mils				-5 : Commercial
4 - LCC 32 pins				-6 : 100% 25°C Probe
				-9 : Industrial
				/883 : MIL STD 883 Class B or S
				DB : Dice Military program
				R : Tape & Reel option
				RD : Tape & Reel/Dry pack option
				D : Dry pack option

The information contained herein is subject to change without notice. No responsibility is assumed by MATRA MHS SA for using this publication and/or circuits described herein : nor for any possible infringements of patents or other rights of third parties which may result from its use.