

## 8 K × 8 Ultimate CMOS SRAM

### Description

The HM 65664A is a very low power CMOS static RAM organized as 8192 × 8 bit. It is manufactured using the MHS high performance CMOS technology named super CMOS.

With this process, MHS is the first to bring the solution for applications where fast computing is as mandatory as low consumption, such as aerospace electronics or portable instruments and PC's.

Using an array of six transistors (6T) memory cells, the HM 65664A combines an extremely low standby supply

current (typical value = 0.1 μA) with a fast access time at 25 ns over the full temperature range. The high stability of the 6T cell provides with excellent protection against soft errors due to noise.

Extra protection against heavy ions is given by the use of an epitaxial layer on a P substrate.

For military/space applications that demand superior levels of performance and reliability the HM 65664A is processed according to the methods of the latest revision of the MIL STD 883 (class B or S) and/or ESA SCC 9000.

### Features

- Access Time  
Industrial/Commercial : 25/35/45/55 ns (max)  
Automotive/Military : 30/35/45/55 ns (max)
- Very Low Power Consumption  
Active : 175.0 mW (Typ)  
Standby : 0.5 μW (Typ)  
Data Retention : 0.4 μW (Typ)
- Wide Temperature Range : -55 To + 125°C
- 300 and 600 Mils Width Packages
- TTL Compatible Inputs and Outputs
- Asynchronous
- Single 5 Volt Supply
- Equal Cycle and Access Time
- Gated Inputs : No Pull-up/Down Resistors Are Required

### Interface

#### Block Diagram

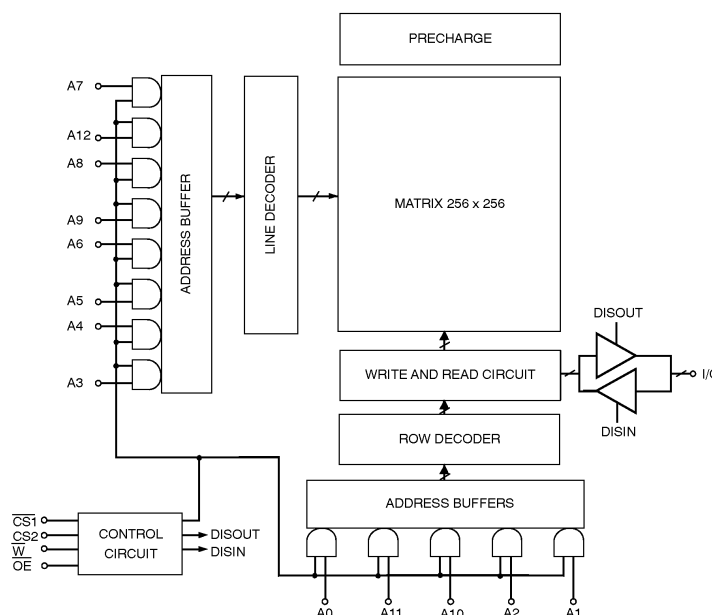

## HM 65664A

### Pin Configuration

Plastic 300 & 600 mils, 28 pins, DIL.  
 Ceramic 300 & 600 mils, 28 pins, DIL.  
 SOIC & SOJ 300 mils, 28 pins  
 SOIC 330 mils, 28 pins

LCC, 32 pins.

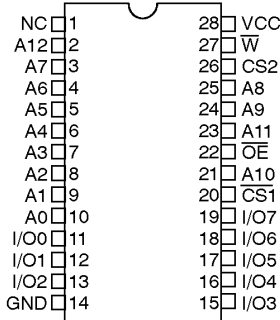

Pinout DIL/SOJ 28 pins (top view)

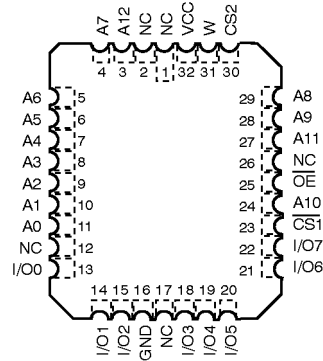

Pinout LCC 32 pins (top view)

### Logic Symbol

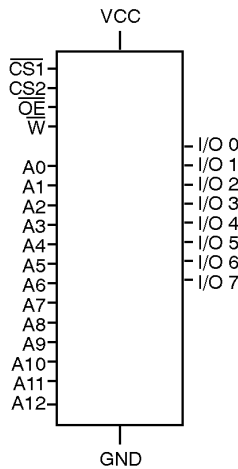

### Pin Names

A0–A12: Address inputs	$\overline{CS1}$ : Chip-select 1
I/O0–I/O7 : Input/Outputs	CS2 : Chip-select 2
VCC : Power	$\overline{OE}$ : Output Enable
GND : Ground	$\overline{W}$ : Write enable

$\overline{CS1}$	CS2	$\overline{OE}$	$\overline{W}$	DATA-IN	DATA-OUT	MODE
H	X	X	X	Z	Z	Deselect
L	H	L	H	Z	Valid	Read
L	H	X	L	Valid	Z	Write
L	H	H	H	Z	Z	Output disable

L = low, H = high, X = H or L, Z = High impedance

### Electrical Characteristics

#### Absolute Maximum Ratings

Supply voltage to GND potential : ..... –0.5 V to +7.0 V  
 Input or Output voltage applied : ..... (Gnd – 0.3 V) to (Vcc + 0.3 V)

Storage temperature : ..... –65°C to +150°C  
 Electro Static Discharge voltage > 2000 V  
 (MILSTD 883C method 3015.2)

#### Operating Range

		OPERATING VOLTAGE	OPERATING TEMPERATURE
Military	(– 2)	$V_{CC} \pm 10\%$	– 55°C to + 125°C
Automotive	(– A)	$V_{CC} \pm 10\%$	– 40°C to + ???
Industrial	(– 9)	$V_{CC} \pm 10\%$	– 40°C to + 85°C
Commercial	(– 5)	$V_{CC} \pm 10\%$	0°C to + 70°C

## Recommended DC Operating Conditions

PARAMETER	DESCRIPTION	MINIMUM	TYPICAL	MAXIMUM	UNIT
VCC	Supply Voltage	4.5	5.0	5.5	V
GND	Ground	0.0	0.0	0.0	V
VIL (1)	Input low voltage	-0.3	0.0	0.8	V
VIH	Input high voltage	2.2	-	Vcc + 0.3 V	V

**Note :** 1. VIL min = -0.3 V or -1.0 V pulse width 50 ns.

## Capacitance

PARAMETER	DESCRIPTION	MINIMUM	TYPICAL	MAXIMUM	UNIT
Cin (2)	Input capacitance	-	-	8	pF
Cout (2)	Output capacitance	-	-	8	pF

**Note :** 2. TA = 25°C, f = 1 MHz, VCC = 5.0 V, these parameters are not tested.

## DC Parameters

PARAMETER	DESCRIPTION	MINIMUM	TYPICAL	MAXIMUM	UNIT
IIX (3)	Input leakage current	-1.0	-	1.0	μA
IOZ (3)	Output leakage current	-1.0	-	1.0	μA
VOL (4)	Output low voltage	-	-	0.4	V
VOH (4)	Output high voltage	2.4	-	-	V

**Note :** 3. Gnd < Vin < Vcc, Gnd < Vout < Vcc, output disabled,  $\overline{CS}_1 \geq 2.2$  V or  $\overline{CS}_2 \leq 0.8$  V.  
4. Vcc min, IOL = 4.0 mA, IOH = -1.0 mA.

## Consumption for Commercial Specification (-5)

SYMBOL	PARAMETER	65664A U-5	65664A T-5	65664A G-5	65664A Q-5	65664A B-5	65664A S-5	65664A -5	65664A C-5	UNIT	VALUE
ICCSB (5)	Standby supply current	10	15	10	15	10	15	10	15	mA	max
ICCSB1 (6)	Standby supply current	1	75	1	75	1	75	1	75	μA	max
ICCOP (8)	Operating supply current	70	80	65	75	65	75	65	75	mA	max

**Notes :** 5.  $\overline{CS}_1 \geq V_{IH}$  and  $CS_2 \leq V_{IL}$ .  
6.  $\overline{CS}_1 \geq V_{cc} - 0.3$  V and  $CS_2 \leq 0.3$  V, Iout = 0 mA.  
7. Vcc max, Iout = 0 mA, f = max, Vin = Gnd/Vcc.

### Consumption for Industrial Specification (-9)

SYMBOL	PARAMETER	65664A U-9	65664A T-9	65664A G-9	65664A Q-9	65664A B-9	65664A S-9	65664A -9	65664A C-9	UNIT	VALUE
ICCSB (5)	Standby supply current	15	20	15	20	15	20	15	20	mA	max
ICCSB1 (6)	Standby supply current	5	100	5	100	5	100	5	100	μA	max
ICCOP (8)	Operating supply current	75	100	75	100	75	100	75	100	mA	max

### Consumption for Automotive (-A) and Military (-2) Specifications

SYMBOL	PARAMETER	65664A G-2	65664A Q-2	65664A B-2	65664A S-2	65664A -2	65664A C-2	UNIT	VALUE
ICCSB (5)	Standby supply current	15	20	15	20	15	20	mA	max
ICCSB1 (6)	Standby supply current	50	500	50	500	50	500	μA	max
IC- COP(7)	Operating supply current	75	100	75	100	75	100	mA	max

- Notes :
5.  $\overline{CS1} \geq V_{IH}$  and  $CS2 \leq V_{IL}$ .
  6.  $\overline{CS1} \geq V_{cc} - 0.3 V$  and  $CS2 \leq 0.3 V$ ,  $I_{out} = 0 mA$ .
  7.  $V_{cc}$  max,  $I_{out} = 0 mA$ ,  $f = \text{max}$ ,  $V_{in} = Gnd/V_{cc}$ .

### AC Parameters

#### AC Conditions

Input pulse levels : ..... Gnd to 3.0 V      Input timing reference levels : ..... 1.5 V  
 Input rise : ..... 5 ns      Output load : ..... 1 TTL gate + 30 pF

#### AC Test Loads and Waveforms

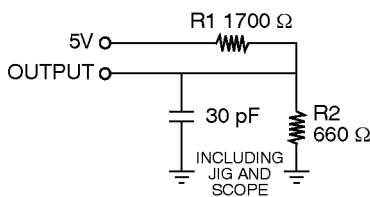

Figure 1  
a

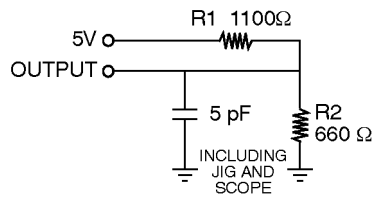

Figure 1 b

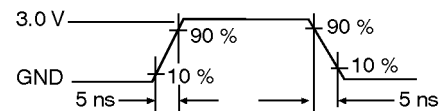
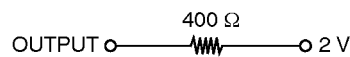

Figure 2

Equivalent to : THEVENIN EQUIVALENT



## Data Retention Mode

MHS CMOS RAM's are designed with battery backup applications in mind. Data retention voltage and supply current are guaranteed over temperature. The following rules insure data retention :

1. Chip select ( $\overline{CS}$ ) must be held high during data retention ; within  $V_{CC}$  to  $V_{CC} - 0.2 V$
2. Output Enable ( $\overline{OE}$ ) should be held high to keep the RAM outputs high impedance, minimizing power dissipation.

2.  $\overline{CS}$  and  $\overline{OE}$  must be kept between  $V_{CC} - 0.3 V$  and 70 % of  $V_{CC}$  during the power up and power down transitions
3. The RAM can begin operation  $> 45 ns$  after  $V_{CC}$  reaches the minimum operating voltage (4.5 V).

## Timing

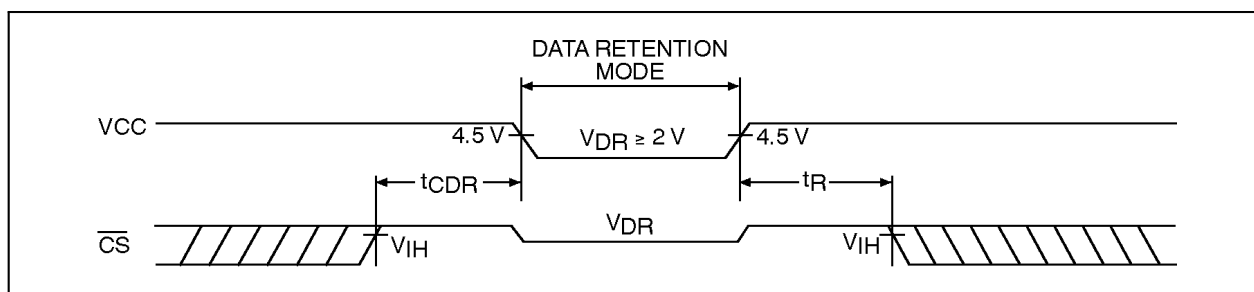

## Data Retention Characteristics

PARAMETER	DESCRIPTION	MINIMUM	TYPICAL (9)	MAXIMUM	UNIT
VCCDR	Vcc for data retention	2.0	-	-	V
TCDR	Chip deselect to data retention time	0.0	-	-	ns
TR	Operation recovery time	TAVAV (10)	-	-	ns
ICCDR1(11)	Data retention current @2.0 V : HM-65664AB/G/U-5 HM-65664AB/G/U-9 HM-65664AB/G-2/-A HM-65664AS/C/Q/T-5 HM-65664AS/C/Q/T-9 HM-65664AS/C/Q-2/-A	- - - - - -	0.1 0.1 0.1 0.1 0.1 0.1	0.5 3.0 20.0 30.0 30.0 200.0	$\mu A$ $\mu A$ $\mu A$ $\mu A$ $\mu A$ $\mu A$
ICCDR2(11)	Data retention current @2.0 V : HM-65664AB/G/U-5 HM-65664AB/G/U-9 HM-65664AB/G-2/-A HM-65664AS/C/Q/T-5 HM-65664AS/C/Q/T-9 HM-65664AS/C/Q-2/-A	- - - - - -	0.3 0.3 0.3 0.3 0.3 0.3	1.0 5.0 30.0 50.0 50.0 300.0	$\mu A$ $\mu A$ $\mu A$ $\mu A$ $\mu A$ $\mu A$

- Notes :
9.  $T_A = 25^\circ C$ .
  10. TAVAV = Read cycle time.
  11.  $\overline{CS} = V_{CC}$ ,  $V_{in} = Gnd/V_{CC}$ , this parameter is only tested to  $V_{CC} = 2 V$ .

### Write Cycle : Commercial Specification

SYMBOL	PARAMETER	65664A U-5	65664A T-5	65664A G-5	65664A Q-5	65664A B-5	65664A S-5	65664A -5	65664A C-5	UNIT	VALUE
TAVAV	Write cycle time	25	25	35	35	45	45	55	55	ns	min
TAVWL	Address set-up time	0	0	0	0	0	0	0	0	ns	min
TAVWH	Address valid to end of write	25	25	35	35	45	45	55	55	ns	min
TDVWH	Data set-up time	20	20	22	22	25	25	25	25	ns	min
TEL1WH	$\overline{CS1}$ low to write end	25	25	35	35	45	45	55	55	ns	min
TEH2WH	CS2 low to write end	25	25	35	35	45	45	55	55	ns	min
TWLQZ (12)	Write low to high Z	15	15	15	15	15	15	20	20	ns	max
TWLWH	Write pulse width	25	25	30	30	40	40	50	50	ns	min
TWHAX	Address hold to end of write	5	5	5	5	5	5	5	5	ns	min
TWHDX	Data hold time	3	3	3	3	3	3	3	3	ns	min
TWHQX (12)	Write high to low Z	0	0	0	0	0	0	0	0	ns	min

### Write Cycle : Industrial, Automotive and Military Specifications

SYMBOL	PARAMETER	65664A U-9	65664A T-9	65664A G-9/-2 /-A	65664A Q-9/-2 /-A	65664A B-9/-2 /-A	65664A S-9/-2 /-A	65664A -9/-2 /-A	65664A C-9/-2 /-A	UNIT	VALUE
TAVAV	Write cycle time	30	30	35	35	45	45	55	55	ns	min
TAVWL	Address set-up time	0	0	0	0	0	0	0	0	ns	min
TAVWH	Address valid to end of write	30	30	35	35	45	45	55	55	ns	min
TDVWH	Data set-up time	22	22	22	22	25	25	25	25	ns	min
TEL1WH	$\overline{CS1}$ low to write end	30	30	35	35	45	45	55	55	ns	min
TEH2WH	CS2 low to write end	30	30	35	35	45	45	55	55	ns	min
TWLQZ (12)	Write low to high Z	15	15	15	15	15	15	20	20	ns	max
TWLWH	Write pulse width	27	27	30	30	40	40	50	50	ns	min
TWHAX	Address hold to end of write	5	5	5	5	5	5	5	5	ns	min
TWHDX	Data hold time	3	3	3	3	3	3	3	3	ns	min
TWHQX(12)	Write high to low Z	0	0	0	0	0	0	0	0	ns	min

**Note :** 12. The data input set-up and hold timing should be referenced to the rising edge of the signal that terminates the write.

### Write Cycle 1 $\overline{W}$ Controlled (note 13)

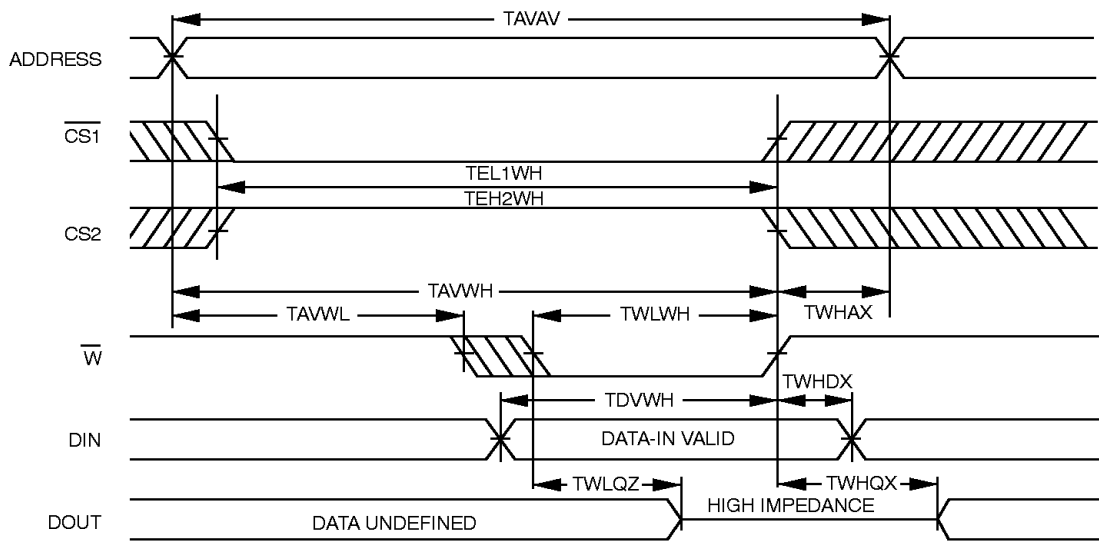

### Write Cycle 2 $\overline{CS}$ 1 Controlled (note 13)

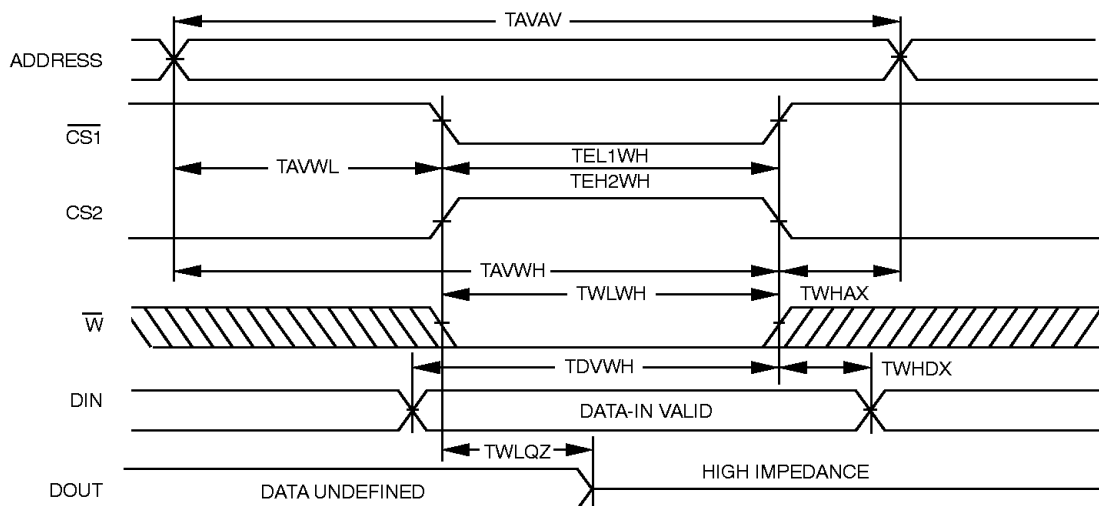

**Note :** 13. The internal write time of the memory is defined by the overlap of  $\overline{CS}$  LOW and  $\overline{W}$  LOW. Both signals must be LOW to initiate a write and either signal can terminate a write by going HIGH. The data input setup and hold timing should be referenced to the rising edge of the signal that terminates the write. Data out is high impedance if  $\overline{OE} = VIH$ .

### Read Cycle : Commercial Specification

SYMBOL	PARAMETER	65664A U-5	65664A T-5	65664A G-5	65664A Q-5	65664A B-5	65664A S-5	65664A -5	65664A C-5	UNIT	VALUE
TAVAV	Read cycle time	25	25	35	35	45	45	55	55	ns	min
TAVQV	Address access time	25	25	35	35	45	45	55	55	ns	max
TAVQX	Address Valid to low Z	3	3	3	3	3	3	3	3	ns	min
TEL1QV	Chip-select 1 access time	25	25	35	35	45	45	55	55	ns	max
TEH2QV	Chip-select 2 access time	25	25	35	35	45	45	55	55	ns	max
TEL1QX	$\overline{CS1}$ low to low Z	5	5	5	5	5	5	5	5	ns	min
TEH2QX	CS2 to low Z	5	5	5	5	5	5	5	5	ns	min
TEH1QZ	$\overline{CS1}$ high to high Z	25	25	35	35	45	45	55	55	ns	max
TEL2QZ	CS2 low to high Z	25	25	35	35	45	45	55	55	ns	max
TGLQV	Output Enable access time	12	12	15	15	15	15	20	20	ns	max
TGLQX	$\overline{OE}$ low to low Z	5	5	5	5	5	5	5	5	ns	min
TGHQZ	$\overline{OE}$ high to high Z	15	15	15	15	15	15	20	20	ns	max

### Read Cycle : Industrial, Automotive and Military Specifications

SYMBOL	PARAMETER	65664A U-9	65664A T-9	65664A G-9/2/A	65664A Q-9/2/A	65664A B-9/2/A	65664A S-9/2/A	65664A -9/2/A	65664A C-9/2/A	UNIT	VALUE
TAVAV	Read cycle time	30	30	35	35	45	45	55	55	ns	min
TAVQV	Address access time	30	30	35	35	45	45	55	55	ns	max
TAVQX	Address Valid to low Z	3	3	3	3	3	3	3	3	ns	min
TEL1QV	Chip-select 1 access time	30	30	35	35	45	45	55	55	ns	max
TEH2QV	Chip-select 2 access time	30	30	35	35	45	45	55	55	ns	max
TEL1QX	$\overline{CS1}$ low to low Z	5	5	5	5	5	5	5	5	ns	min
TEH2QX	CS2 to low Z	5	5	5	5	5	5	5	5	ns	min
TEH1QZ	$\overline{CS1}$ high to high Z	30	30	35	35	45	45	55	55	ns	max
TEL2QZ	CS2 low to high Z	30	30	35	35	45	45	55	55	ns	max
TGLQV	Output Enable access time	15	15	15	15	15	15	20	20	ns	max
TGLQX	$\overline{OE}$ low to low Z	5	5	5	5	5	5	5	5	ns	min
TGHQZ	$\overline{OE}$ high to high Z	15	15	15	15	15	15	20	20	ns	max

### Read Cycle nb 1 (notes 16, 17)

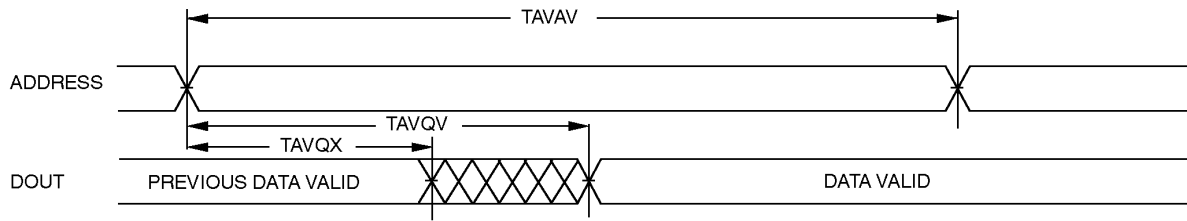

### Read Cycle nb 2 (notes 16, 18)

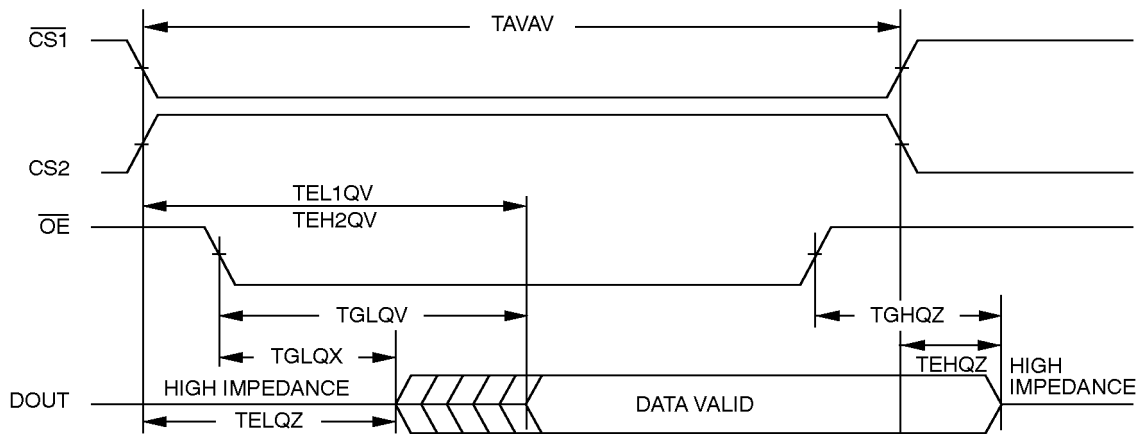

- Notes :**
- 16.  $\overline{W}$  is high for read cycle.
  - 17. Device is continuously selected,  $\overline{CS1}$  &  $\overline{OE} = V_{IL}$  AND  $CS2 = V_{IH}$ .
  - 18. Address valid prior to or coincident with  $\overline{CS}$  transition low.

## HM 65664A

### Burn-in Schematics

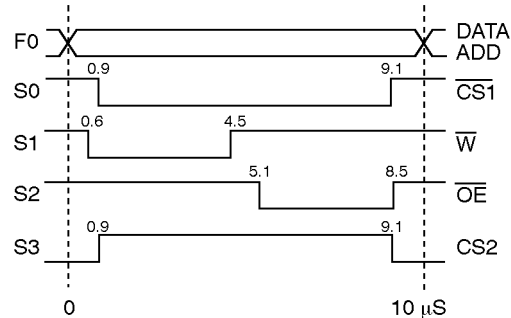
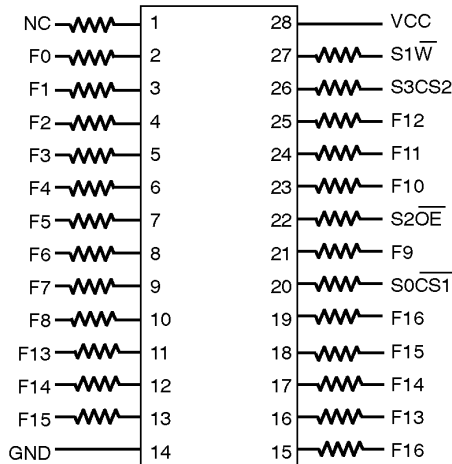

VCC = 5 V (-0, + 0.5)

R = 1 K $\Omega$  per pin

FO = 50 KHz  $\pm$  20%

$F_n = 1/2 F_{n-1}$

SO to S3 : programmable signals for write/read cycles

NC : Not Connected

### Ordering Information

PACKAGE		DEVICE TYPE	GRADE	LEVEL
<b>HM</b>	<b>U</b>	<b>65664A</b>	<b>B</b>	<b>-5 : R</b>
0 - Chip form		8 k $\times$ 8 Ultimate CMOS static RAM		-A : Automotive
1 - Ceramic 28 pins 300 mils				-2 : Military
1E - Ceramic 28 pins 600 mils				-5 : Commercial
3 - Plastic 28 pins 300 mils				-6 : 100% 25°C Probe
3E - Plastic 28 pins 600 mils				-9 : Industrial
4 - LCC 32 pins				/883 : MIL STD 883 CLASS B OR S
T - SOIC 300 mils 28 pins				DB : Dice Military program
TP - SOIC 330 mils 28 pins				R : Tape & Reel option
U - SOJ 28 pins 300 mils				RD : Tape & Reel/Dry pack option
				D : Dry pack option

(\* ) for commercial, 30 ns for other levels

The information contained herein is subject to change without notice. No responsibility is assumed by MATRA MHS SA for using this publication and/or circuits described herein : nor for any possible infringements of patents or other rights of third parties which may result from its use.