

# DATA SHEET

For a complete data sheet, please also download:

- The IC04 LOCMOS HE4000B Logic Family Specifications HEF, HEC
- The IC04 LOCMOS HE4000B Logic Package Outlines/Information HEF, HEC

## **HEF4738V** **LSI** **IEC/IEEE bus interface**

Product specification  
File under Integrated Circuits, IC04

January 1995

**IEC/IEEE bus interface**

**HEF4738V  
LSI**

**DESCRIPTION**

The HEF4738V is an implementation of the IEC-bus as described in IEC report 66 CO 22 (interface system for programmable measuring apparatus) as well as in IEEE standard 488-1975 (standard digital interface for programmable instrumentation).

Together with bus-drivers, level converters and multiplexers it is suitable for connecting electronic programmable and non-programmable equipment to an IEC/IEEE interface bus.

All inputs have standard HE4000B family levels. In the circuit the following standard interface functions are incorporated:

- Complete source handshake (subset SH1)
- Complete acceptor handshake (subset AH1)
- Basic talker with serial poll and talk-only mode (when It = LOW, subset T1; It = HIGH, subset T5)
- Basic listener with listen-only mode (when It = LOW, subset L1; It = HIGH, subset L3)
- Complete service request (subset SR1)
- Complete remote local (subset RL1)
- Remote parallel poll configuration (subset PP1)
- Complete device clear (subset DC1)
- Complete device trigger (subset DT1)
- Some controller facilities

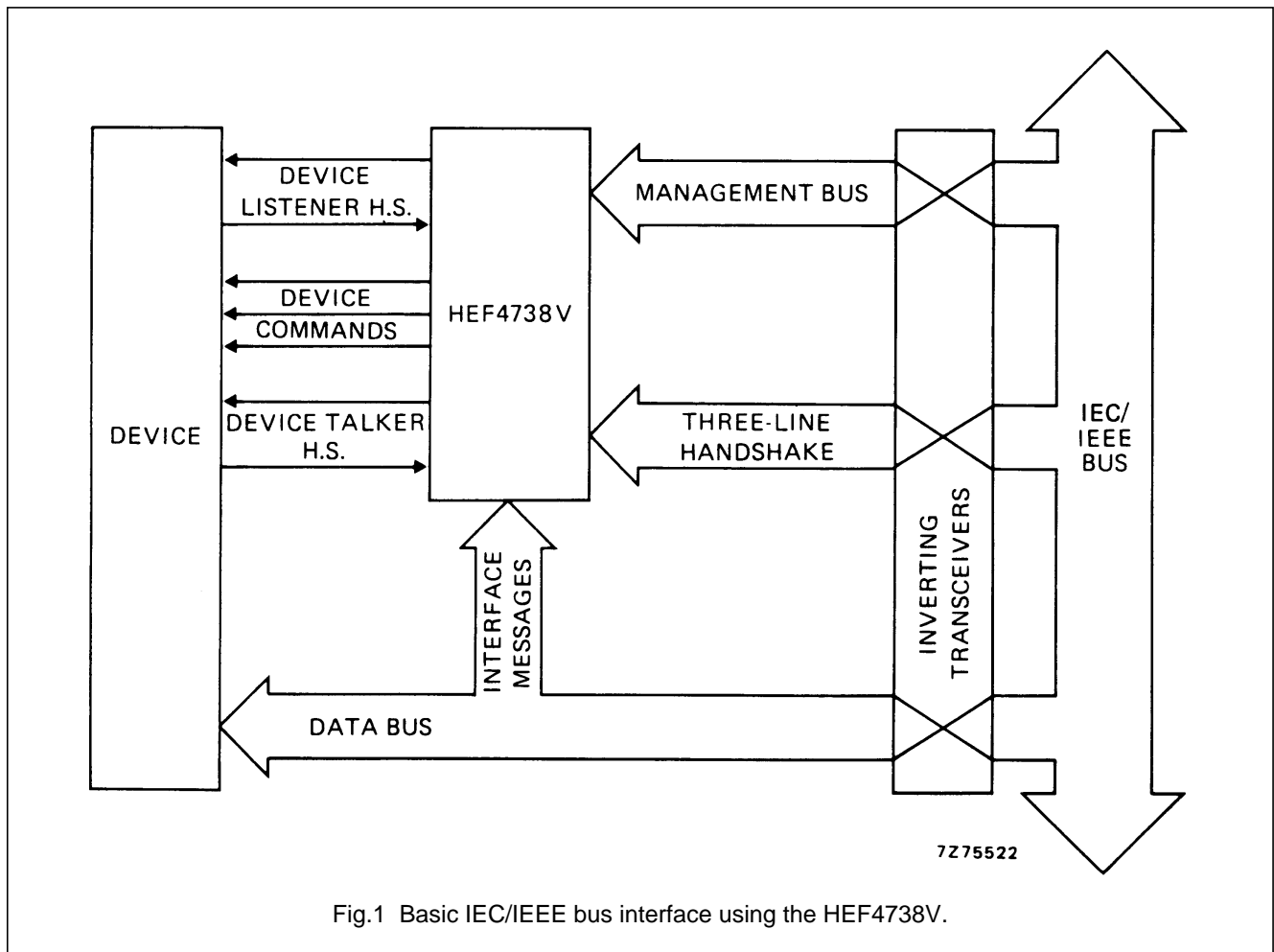

Fig.1 Basic IEC/IEEE bus interface using the HEF4738V.

**SUPPLY VOLTAGE**

RATING	RECOMMENDED OPERATING
-0,5 to 18	4,5 to 12,5 V

**FAMILY DATA, I<sub>DD</sub> LIMITS category LSI**

See Family Specifications

## IEC/IEEE bus interface

HEF4738V  
LSI**GENERAL DESCRIPTION**

The inputs IRFD, IDAC,  $\overline{\text{IDAV}}$ ,  $\overline{\text{IFC}}$ ,  $\overline{\text{IREN}}$ ,  $\overline{\text{IATN}}$ ,  $\overline{\text{IDY}}$  and IDIO1 to IDIO7 must be connected via an inverting TTL to LOC MOS level converter to the respective bus lines: NRFD, NDAC, DAV, IFC, REN, ATN, IDY and DIO1 to DIO7.

The outputs ORFD, ODAC,  $\overline{\text{ODAV}}$  and  $\overline{\text{OSRQ}}$  can drive one standard TTL load and are suitable for driving NRFD, NDAC, DAV and SRQ via an inverting bus-driver circuit. The parallel poll outputs OP1, OP2, OP3 and OPP can also drive one standard TTL load. Outputs OP1, OP2 and OP3 are connected to flip-flops, which store the attendant bits P1, P2 and P3 of the last PPE message. OP1, OP2 and OP3 have to be decoded externally and multiplexed to the DIO-lines when OPP is LOW.

All other output stages are standard HE4000B family. Most of the functions in the IEC/IEEE interface IC are realized with synchronous sequential logic, which is driven from the clock input CP. HIGH to LOW transitions are used to synchronize input signals and LOW to HIGH transitions trigger the internal flip-flops. In order to meet the IEC/IEEE timing specifications, the maximum clock frequency is 2 MHz. The maximum data transfer is then 200 kbytes/second.

Input  $\overline{\text{Irdy}}$  (not ready for next message) and output Odvd (data valid device) are intended for a two-wire handshake procedure between the acceptor function in the IC and the data input of the device (instrument to be connected to the interface system). The procedure is made so, that if the device reacts fast enough, the handshake procedure can be omitted by interconnecting Odvd and  $\overline{\text{Irdy}}$ . The conditions to be fulfilled by the device are:

- The device must be able to accept a data byte within one clock period after dvd goes HIGH under all conditions.
- The device must be ready to process a data byte within two clock periods plus the minimum settling time of the talker devices under all conditions.

Input  $\overline{\text{Inba}}$  (not new byte available) and output Odcd (don't change data) are intended for a two-wire handshake procedure with the source function in the IC and the data output of the device (instrument). The procedure is so made that if the device reacts fast enough the handshake procedure can be omitted by interconnecting Odcd and  $\overline{\text{Inba}}$ . The conditions to be fulfilled by the device are:

- The device must be able to set a new data byte on the bus within one clock period after dcd goes LOW under all conditions.
- The device must be able to have the next data byte available within seven clock periods under all conditions.

Input  $\overline{\text{Isr}}$  and output Ored should be connected to an external parallel-in/serial-out (when Ored is HIGH parallel-in, when LOW serial-out) shift register, which must be connected to the clock CP and must trigger on the LOW to HIGH transitions. The data on the parallel inputs of this external shift register are loaded in parallel and shifted-out via input  $\overline{\text{Isr}}$  into an internal shift register. The eleven serial input signals are in the order of shifting: A5, A4, A3, A2, A1, ton, lon, lt, rsv, rtl and ist.

Signals A5, A4, A3, A2 and A1 represent the device talker and listener address. When signal lt (either listener or talker) is HIGH, a listener addressing sets the talker to the idle state and a talker addressing sets the listener to the idle state (subset T5 and L3). With lt LOW, the device can be addressed to be a listener and a talker. Because of the serial input procedure, all these input signals arrive in the interface functions of the IC between 16 and 32 clock cycles.

The signals ton, lon, rsv, rtl and ist are standard IEC/IEEE inputs. When using ton or lon no controller action is possible.

The output Oclr or Otrg is HIGH for one clock pulse if DCAS (device clear active state) or DTAS (device trigger active state) respectively is active.

The output Oloc is HIGH when LOCS (local state) or LWLS (local with lock-out state) is active. Output  $\overline{\text{OSRQ}}$  is HIGH when the rsv signal is read from the external shift register and the SRQS (request service state) is active. After this request has been answered by a serial poll,  $\overline{\text{ORQS}}$  is HIGH in the APRS (affirmative poll response state). The inverted signal on  $\overline{\text{ORQS}}$  must be multiplexed to bus-line DIO7, together with the status byte of the other DIO lines, when output Osp is HIGH in the SPAS (serial poll active state).

When the device is in the SPAS state the signal rsv may be removed (can be checked on  $\overline{\text{ORQS}}$ ). N.B.: When the interface has asked for service via rsv and is addressed as talker in the serial poll mode, a handshake must be initialized by the device via  $\overline{\text{Inba}}$ .

Input  $\overline{\text{Icats}}$  and output Otct are intended for use of this IC in a controller. When  $\overline{\text{Icats}}$  is HIGH, the source handshake function will exit SIDS and SIWS and enter respectively SGNS and SWNS. When the controller function is not used, the input  $\overline{\text{Icats}}$  must be connected to  $V_{SS}$ . Output Otct is HIGH if the tct message is sent over the interface and the ACDS state is active. A HIGH on input  $\overline{\text{Ipon}}$  sets each function to its initial state. This level can be set to LOW after the IC has received 32 clock pulses at stabilized supply voltage.

IEC/IEEE bus interface

HEF4738V  
LSI

**Note**

After power-on the input Ipon must stay LOW for at least 32 clock pulses, then HIGH for 32 clock pulses in order to force the function to its initial state. After this, Ipon must be set LOW.

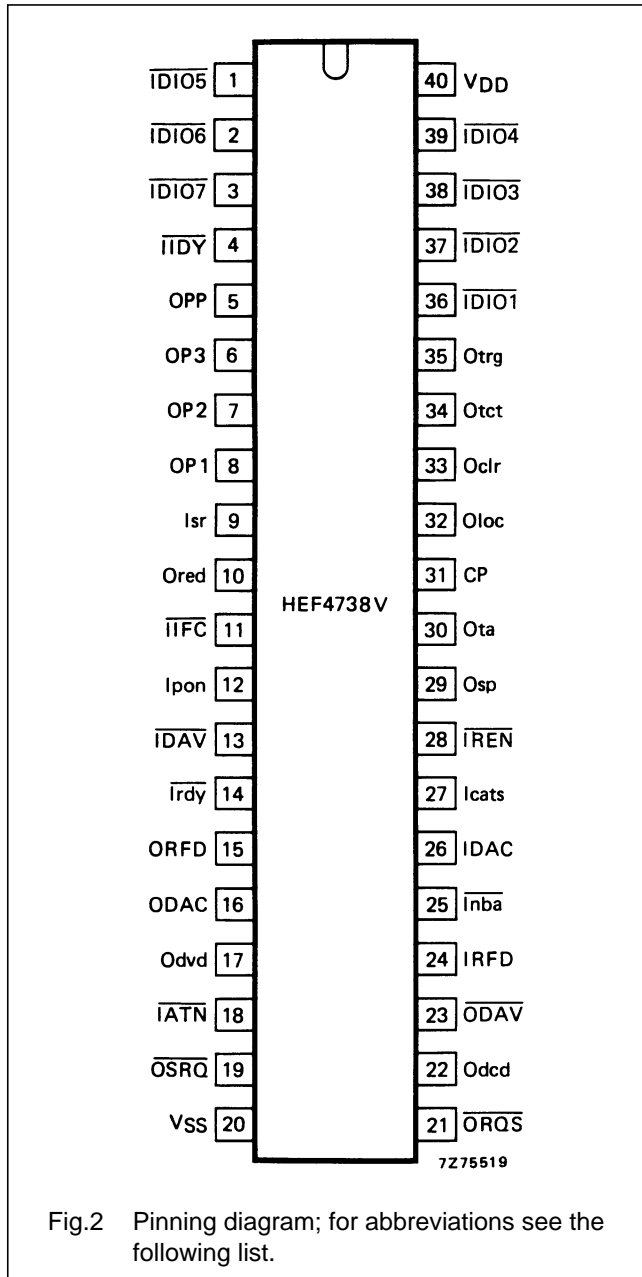

Fig.2 Pinning diagram; for abbreviations see the following list.

**Input pins**

- 1,2,3,36, 37, 38, 39 = ID101 to 7: input DIO
- 4 = IIDY input IDY not
- 9 = Isr (note 1) input shift register
- 11 = IIFC input IFC not
- 12 = Ipon input pon
- 13 = IDAV input DAV not
- 14 = Irdy input rdy not
- 18 = IATN input ATN not
- 24 = IRFD input RFD
- 25 = Inba input nba not
- 26 = IDAC input DAC
- 27 = Icats inputs cats
- 28 = IREN input REN not
- 31 = CP clock pulse input

**Output pins**

- 5 = OPP output PP
- 8,7,6, = OP1 to OP3 output P1 to P3
- 10 = Ored output red
- 15 = ORFD output RFD
- 16 = ODAC output DAC
- 17 = Odvd output dvd
- 19 = OSRQ output SRQ not
- 21 = ORQS output RQS not
- 22 = Odcd output dcd
- 23 = ODAV output DAV not
- 29 = Osp output sp
- 30 = Ota output ta
- 32 = Oloc output loc
- 33 = Oclr output clr
- 34 = Otct output tct
- 35 = Otrg output trg

**Supply pins**

- 20 = VSS: more negative supply line
- 40 = VDD: more positive supply line

**Note**

1. Isr is serial input for signals A5, A4, A3, A2, A1, ton, lon, lt, rsv, rtl and ist.

HEF4738VP(N): 40-lead DIL; plastic (SOT129-1)  
( ): Package Designator North America

IEC/IEEE bus interface

HEF4738V  
LSI

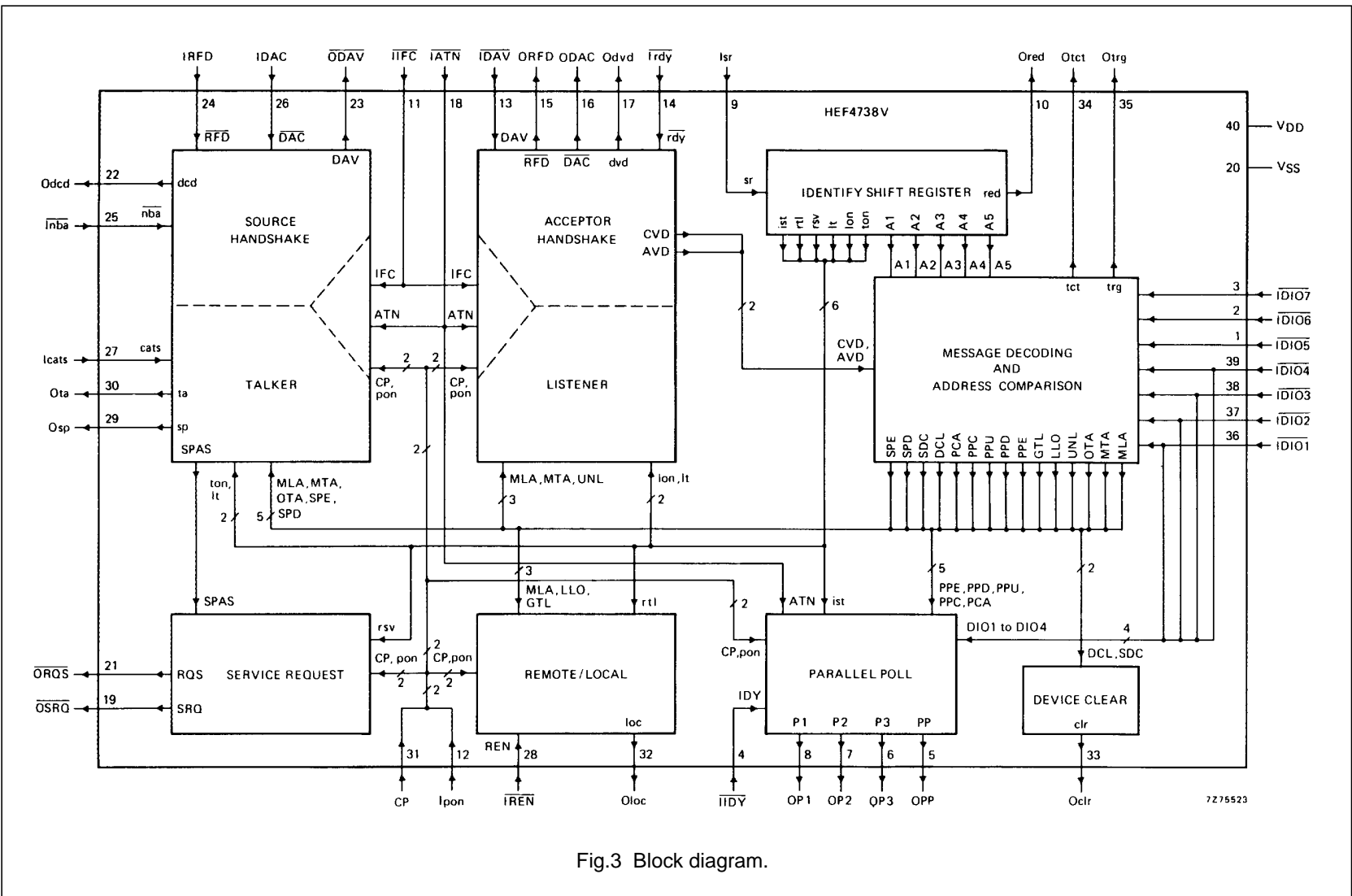

Fig.3 Block diagram.

Note

Because the circuit uses positive logic and the bus uses negative logic, all inputs and outputs to the bus must be inverted. For that reason, all terminals that are working with the bus have mnemonics which are the inverted ones of those on the bus.

## IEC/IEEE bus interface

HEF4738V  
LSI

## LIST OF USED ABBREVIATIONS

A1 to A5	address	PPE	parallel poll enable
ACDS	acceptor data state	PPU	parallel poll unconfigure
APRS	affirmative poll response state	rdy	ready for next message
ATN	attention	red	ready for next shift cycle
AVD	address valid	REN	remote enable
cats	controller active or transfer state	RFD	ready for data
clr	device clear	RQS	requested service
CVD	command valid	rsv	request for service
DAC	data accepted	rtl	return to local
DAV	data valid	SDC	selected device clear
DCAS	device clear active state	SGNS	source generate state
dcd	don't change data	SIDS	source idle state
DCL	device clear	SIWS	source idle wait state
DIO	data input output	sp	serial poll
DTAS	device trigger active state	SPAS	serial poll active state
dvd	data valid device	SPD	serial poll disable
EOI	end of output/identify	SPE	serial poll enable
GTL	go to local	sr	shift register
IDY	identify	SRQ	service request
IFC	interface clear	SRQS	request service state
ist	individual status	SWNS	source wait for new cycle state
LLO	local lock-out	ta	talker active
loc	local	tct	talk control
LOCS	local state	ton	talk only
lon	listen only	trg	trigger
It	decides whether the device can only be listener/talker or listener and talker simultaneously	UNL	unlisten
LWLS	local with lock-out state		
MLA	my listen address		
MTA	my talk address		
nba	new byte available		
NRFD	not ready for data		
NDAC	not data accepted		
OTA	other talk address		
P1 to P3	parallel response messages		
PCA	parallel poll configure accepted		
pon	power on		
PP	parallel poll message enable		
PPC	parallel poll configure		
PPD	parallel poll disable		

IEC/IEEE bus interface

HEF4738V  
LSI

DC CHARACTERISTICS

V<sub>SS</sub> = 0 V

	V <sub>DD</sub> V	V <sub>OL</sub> V	V <sub>OH</sub> V	SYMBOL	T <sub>amb</sub> (°C)						
					-40		+ 25		+ 85		
					MIN.	MAX.	MIN.	MAX.	MIN.	MAX.	
Output current HIGH; see note	5		2,5	-I <sub>OH</sub>	3		2,5		2,0	mA	
	5		4,6		1		0,85		0,65		
	10		9,5		3		2,5		2,0		
Output current LOW; see note	4,75	0,4		I <sub>OL</sub>	2,7		2,3		1,8	mA	
	10	0,5			9,5		8,0		6,3		
Quiescent device current	5			I <sub>DD</sub>		50		50		375	µA
	10					100		100		750	

Note

- Output currents for pins: 5 = OPP, 6 = OP3, 7 = OP2, 8 = OP1, 15 = ORFD, 16 = ODAC; 19 =  $\overline{\text{OSRQ}}$ , 23 =  $\overline{\text{ODAV}}$ . These pins can drive one standard TTL load.

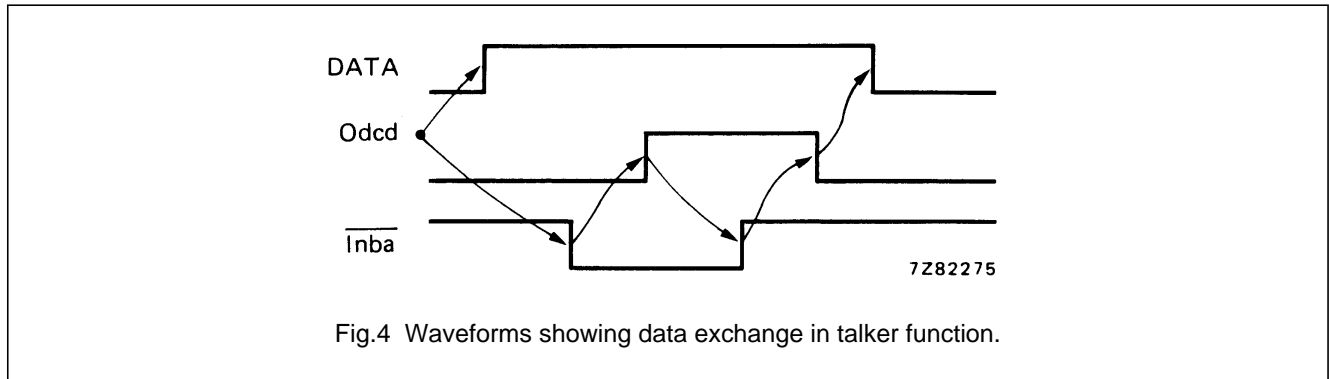

Fig.4 Waveforms showing data exchange in talker function.

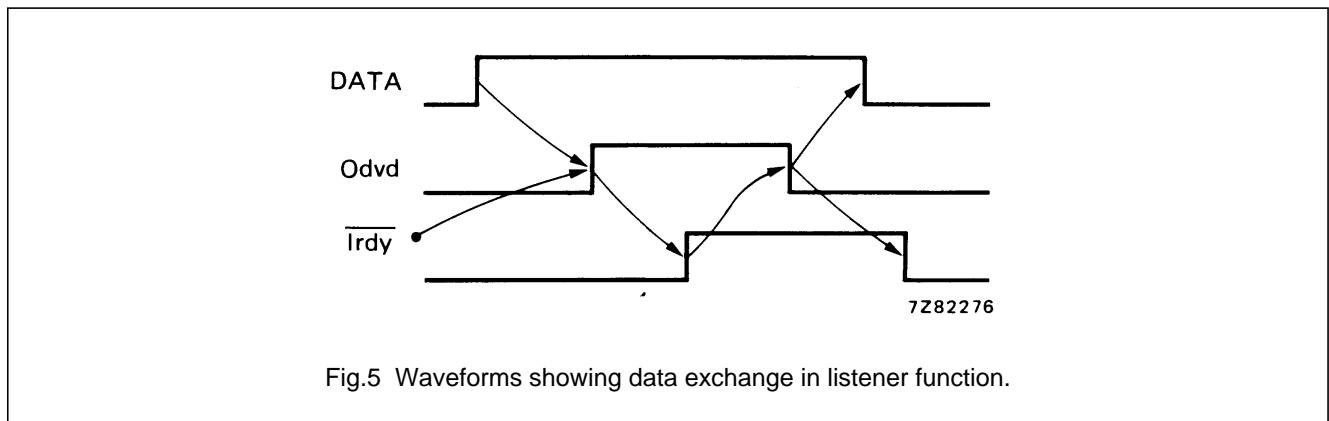

Fig.5 Waveforms showing data exchange in listener function.

IEC/IEEE bus interface

HEF4738V  
LSI

APPLICATION INFORMATION

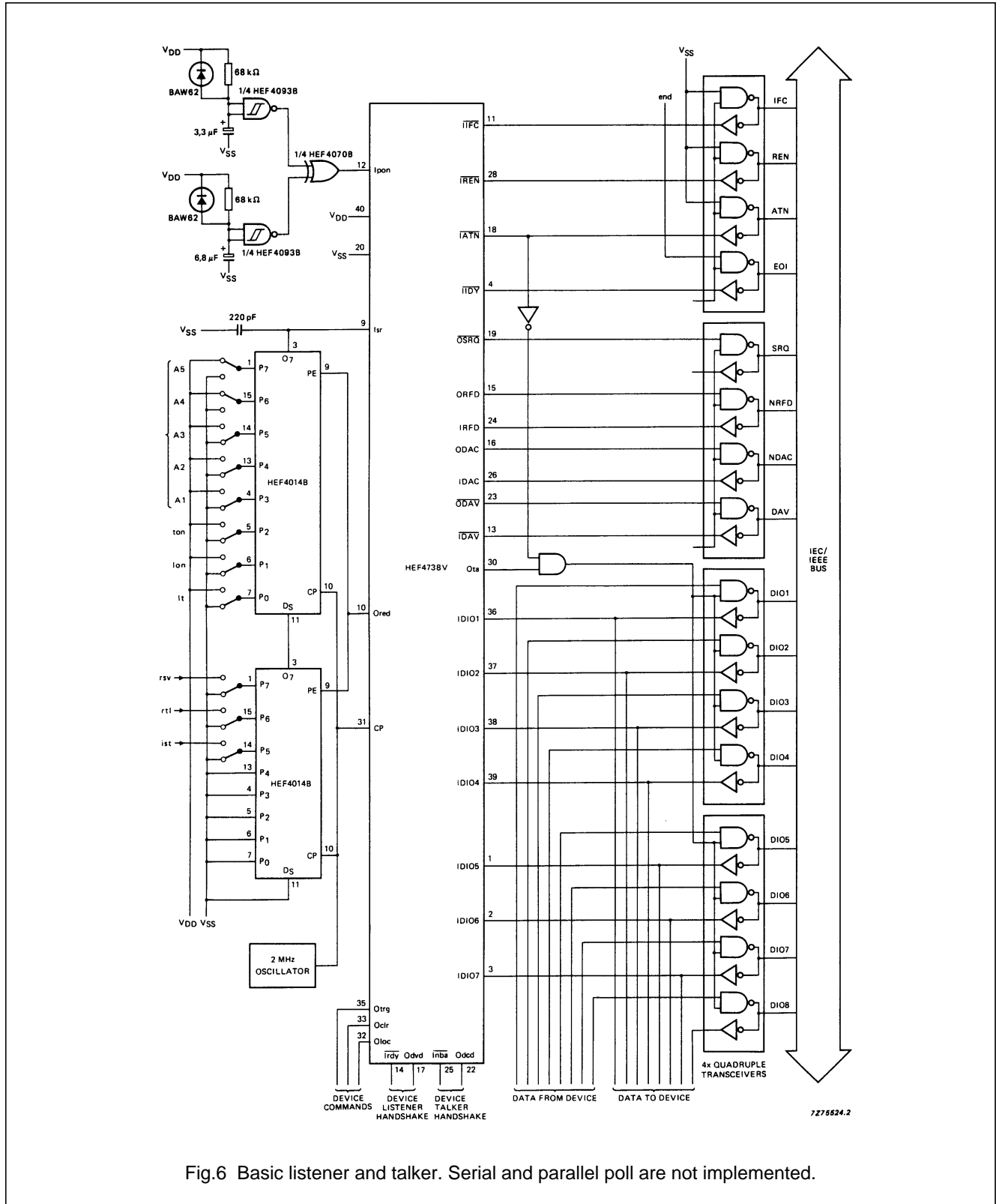

Fig.6 Basic listener and talker. Serial and parallel poll are not implemented.