

DATA SHEET

For a complete data sheet, please also download:

- The IC04 LOCMOS HE4000B Logic Family Specifications HEF, HEC
- The IC04 LOCMOS HE4000B Logic Package Outlines/Information HEF, HEC

HEF4027B **flip-flops** Dual JK flip-flop

Product specification
File under Integrated Circuits, IC04

January 1995

Dual JK flip-flop

HEF4027B flip-flops

DESCRIPTION

The HEF4027B is a dual JK flip-flop which is edge-triggered and features independent set direct (S_D), clear direct (C_D), clock (CP) inputs and outputs (O, \bar{O}). Data is accepted when CP is LOW, and transferred to the output on the positive-going edge of the clock. The active HIGH asynchronous clear-direct (C_D) and set-direct (S_D) are independent and override the J, K, and CP inputs. The outputs are buffered for best system performance. Schmitt-trigger action in the clock input makes the circuit highly tolerant to slower clock rise and fall times.

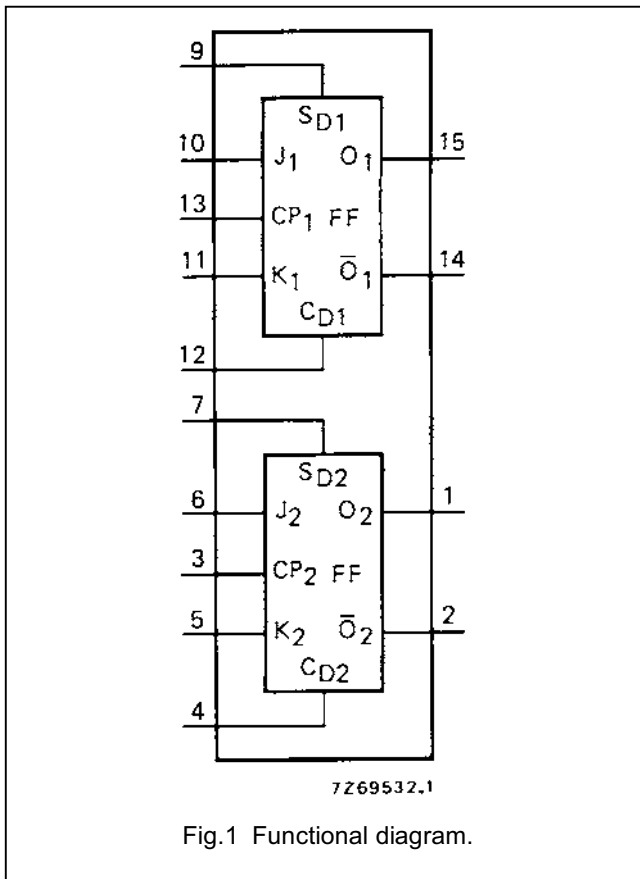

Fig.1 Functional diagram.

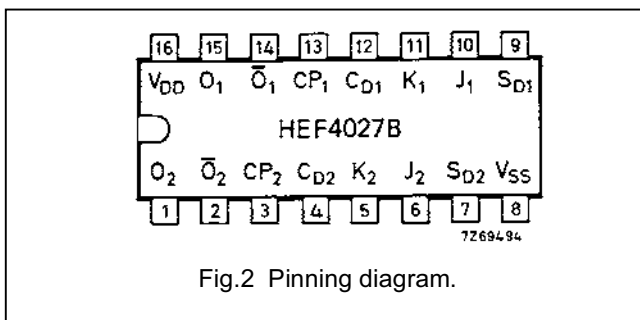

Fig.2 Pinning diagram.

FUNCTION TABLES

INPUTS					OUTPUTS	
S_D	C_D	CP	J	K	O	\bar{O}
H	L	X	X	X	H	L
L	H	X	X	X	L	H
H	H	X	X	X	H	H

INPUTS					OUTPUTS	
S_D	C_D	CP	J	K	O_{n+1}	\bar{O}_{n+1}
L	L	↗	L	L	no change	
L	L	↗	H	L	H	L
L	L	↗	L	H	L	H
L	L	↗	H	H	\bar{O}_n	O_n

Notes

- H = HIGH state (the more positive voltage)
L = LOW state (the less positive voltage)
X = state is immaterial
↗ = positive-going transition
 O_{n+1} = state after clock positive transition

PINNING

- J,K synchronous inputs
- CP clock input (L to H edge-triggered)
- S_D asynchronous set-direct input (active HIGH)
- C_D asynchronous clear-direct input (active HIGH)
- O true output
- \bar{O} complement output

- HEF4027BP(N): 16-lead DIL; plastic (SOT38-1)
- HEF4027BD(F): 16-lead DIL; ceramic (cerdip) (SOT74)
- HEF4027BT(D): 16-lead SO; plastic (SOT109-1)
- (): Package Designator North America

FAMILY DATA, I_{DD} LIMITS category FLIP-FLOPS

See Family Specifications

Dual JK flip-flop

HEF4027B
flip-flops

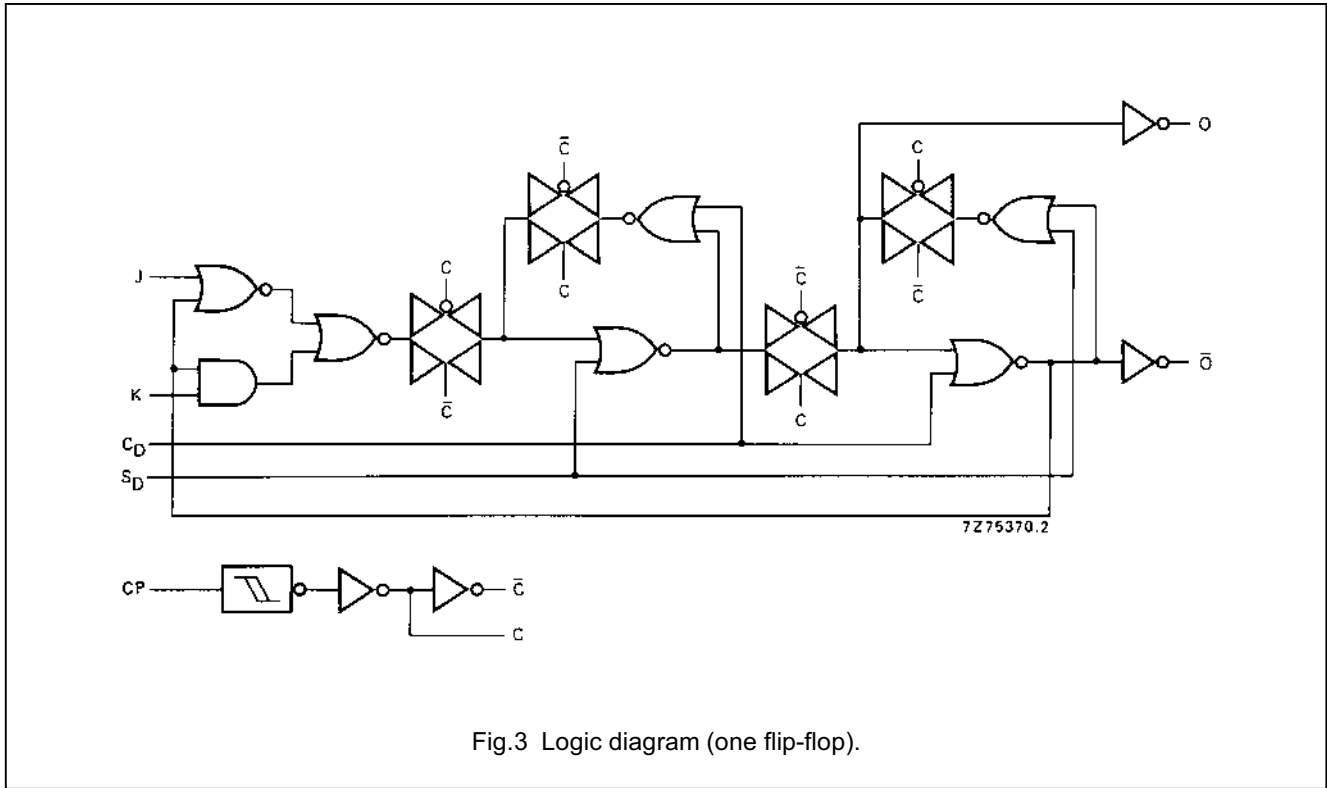

Fig.3 Logic diagram (one flip-flop).

AC CHARACTERISTICS

V_{SS} = 0 V; T_{amb} = 25 °C; C_L = 50 pF; input transition times ≤ 20 ns

	V _{DD} V	SYMBOL	MIN.	TYP.	MAX.	TYPICAL EXTRAPOLATION FORMULA
Propagation delays						
CP → O, O-bar	5			105	210 ns	78 ns + (0,55 ns/pF) C _L
HIGH to LOW	10	t _{PHL}		40	80 ns	29 ns + (0,23 ns/pF) C _L
	15			30	60 ns	22 ns + (0,16 ns/pF) C _L
LOW to HIGH	5			85	170 ns	58 ns + (0,55 ns/pF) C _L
	10	t _{PLH}		35	70 ns	27 ns + (0,23 ns/pF) C _L
	15			30	60 ns	22 ns + (0,16 ns/pF) C _L
S _D → O						
LOW to HIGH	5			70	140 ns	43 ns + (0,55 ns/pF) C _L
	10	t _{PLH}		30	60 ns	19 ns + (0,23 ns/pF) C _L
	15			25	50 ns	17 ns + (0,16 ns/pF) C _L
C _D → O						
HIGH to LOW	5			120	240 ns	93 ns + (0,55 ns/pF) C _L
	10	t _{PHL}		45	90 ns	33 ns + (0,23 ns/pF) C _L
	15			35	70 ns	27 ns + (0,16 ns/pF) C _L
S _D → O-bar						
HIGH to LOW	5			140	280 ns	113 ns + (0,55 ns/pF) C _L
	10	t _{PHL}		55	110 ns	44 ns + (0,23 ns/pF) C _L
	15			40	80 ns	32 ns + (0,16 ns/pF) C _L

Dual JK flip-flop

HEF4027B
flip-flops

	V _{DD} V	SYMBOL	MIN.	TYP.	MAX.	TYPICAL EXTRAPOLATION FORMULA
C _D → \bar{O} LOW to HIGH	5	t _{PLH}		75	150 ns	48 ns + (0,55 ns/pF) C _L
	10			35	70 ns	24 ns + (0,23 ns/pF) C _L
	15			25	50 ns	17 ns + (0,16 ns/pF) C _L
Output transition times HIGH to LOW	5	t _{THL}		60	120 ns	10 ns + (1,0 ns/pF) C _L
	10			30	60 ns	9 ns + (0,42 ns/pF) C _L
	15			20	40 ns	6 ns + (0,28 ns/pF) C _L
LOW to HIGH	5	t _{TLH}		60	120 ns	10 ns + (1,0 ns/pF) C _L
	10			30	60 ns	9 ns + (0,42 ns/pF) C _L
	15			20	40 ns	6 ns + (0,28 ns/pF) C _L
Set-up time J,K → CP	5	t _{su}	50	25	ns	see also waveforms Figs 4 and 5
	10		30	10	ns	
	15		20	5	ns	
Hold time J,K → CP	5	t _{hold}	25	0	ns	
	10		20	0	ns	
	15		15	5	ns	
Minimum clock pulse width; LOW	5	t _{WCPL}	80	40	ns	
	10		30	15	ns	
	15		24	12	ns	
Minimum S _D , C _D pulse width; HIGH	5	t _{WSDH} , t _{WCDH}	90	45	ns	
	10		40	20	ns	
	15		30	15	ns	
Recovery time for S _D , C _D	5	t _{RS D} , t _{RC D}	20	-15	ns	
	10		15	-10	ns	
	15		10	-5	ns	
Maximum clock pulse frequency J = K = HIGH	5	f _{max}	4	8	MHz	see also waveforms Fig.4
	10		12	25	MHz	
	15		15	30	MHz	

	V _{DD} V	TYPICAL FORMULA FOR P (μW)	
Dynamic power dissipation per package (P)	5	900 f _i + ∑ (f _o C _L) × V _{DD} ²	where f _i = input freq. (MHz) f _o = output freq. (MHz) C _L = load capacitance (pF) ∑ (f _o C _L) = sum of outputs V _{DD} = supply voltage (V)
	10	4 500 f _i + ∑ (f _o C _L) × V _{DD} ²	
	15	13 200 f _i + ∑ (f _o C _L) × V _{DD} ²	

Dual JK flip-flop

HEF4027B
flip-flops

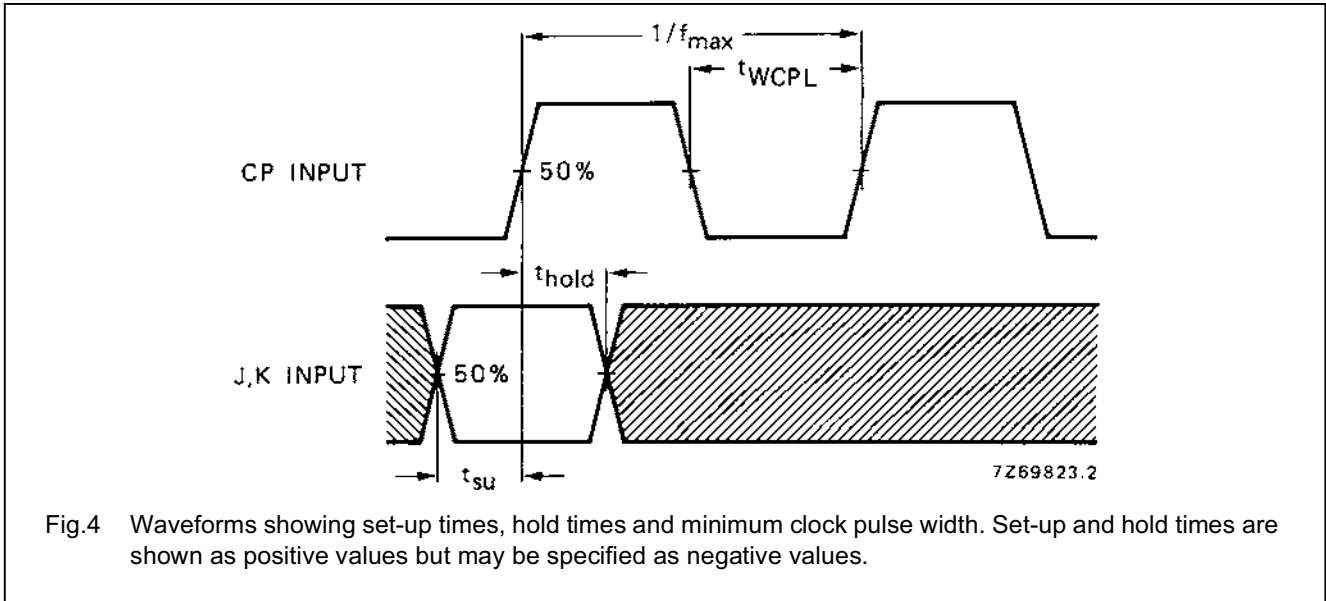

Fig.4 Waveforms showing set-up times, hold times and minimum clock pulse width. Set-up and hold times are shown as positive values but may be specified as negative values.

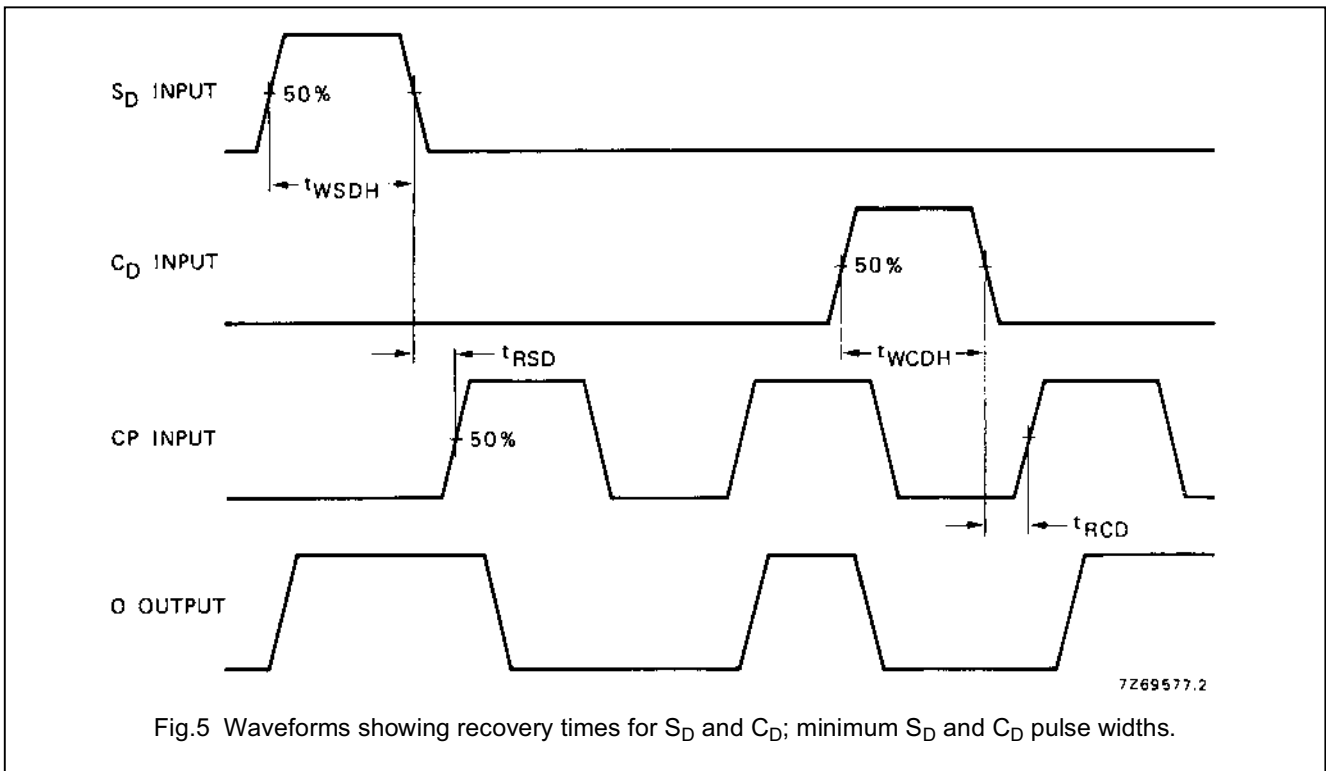

Fig.5 Waveforms showing recovery times for S_D and C_D ; minimum S_D and C_D pulse widths.

APPLICATION INFORMATION

Some examples of applications for the HEF4027B are:

- Registers
- Counters
- Control circuits