

DATA SHEET

For a complete data sheet, please also download:

- The IC04 LOCMOS HE4000B Logic Family Specifications HEF, HEC
- The IC04 LOCMOS HE4000B Logic Package Outlines/Information HEF, HEC

HEF4023B **gates** Triple 3-input NAND gate

Product specification
File under Integrated Circuits, IC04

January 1995

Triple 3-input NAND gate

**HEF4023B
gates**

DESCRIPTION

The HEF4023B provides the positive triple 3-input NAND function. The outputs are fully buffered for highest noise immunity and pattern insensitivity of output impedance.

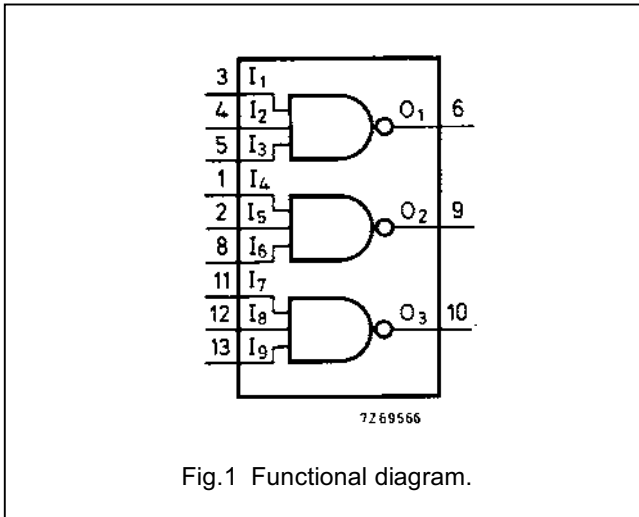

Fig.1 Functional diagram.

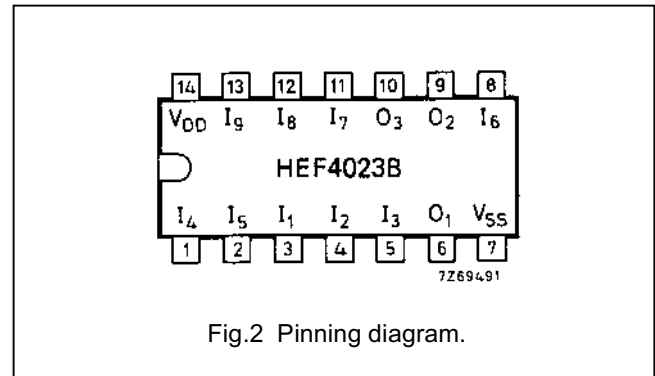

Fig.2 Pinning diagram.

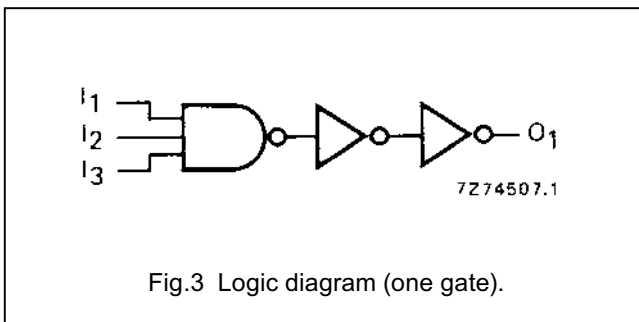

Fig.3 Logic diagram (one gate).

- HEF4023BP(N): 14-lead DIL; plastic (SOT27-1)
- HEF4023BD(F): 14-lead DIL; ceramic (cerdip) (SOT73)
- HEF4023BT(D): 14-lead SO; plastic (SOT108-1)
- (): Package Designator North America

FAMILY DATA, I_{DD} LIMITS category GATES

See Family Specifications

Triple 3-input NAND gate

HEF4023B
gates**AC CHARACTERISTICS** $V_{SS} = 0\text{ V}$; $T_{amb} = 25\text{ °C}$; $C_L = 50\text{ pF}$; input transition times $\leq 20\text{ ns}$

	V_{DD} V	SYMBOL	TYP.	MAX.		TYPICAL EXTRAPOLATION FORMULA
Propagation delays $I_n \rightarrow O_n$	5 10 15	t_{PHL}	65	135	ns	$38\text{ ns} + (0,55\text{ ns/pF}) C_L$
			25	50	ns	$14\text{ ns} + (0,23\text{ ns/pF}) C_L$
			15	30	ns	$7\text{ ns} + (0,16\text{ ns/pF}) C_L$
	5 10 15	t_{PLH}	65	130	ns	$38\text{ ns} + (0,55\text{ ns/pF}) C_L$
			30	60	ns	$19\text{ ns} + (0,23\text{ ns/pF}) C_L$
			25	45	ns	$17\text{ ns} + (0,16\text{ ns/pF}) C_L$
Output transition times	5 10 15	t_{THL}	60	120	ns	$10\text{ ns} + (1,0\text{ ns/pF}) C_L$
			30	60	ns	$9\text{ ns} + (0,42\text{ ns/pF}) C_L$
			20	40	ns	$6\text{ ns} + (0,28\text{ ns/pF}) C_L$
	5 10 15	t_{TLH}	60	120	ns	$10\text{ ns} + (1,0\text{ ns/pF}) C_L$
			30	60	ns	$9\text{ ns} + (0,42\text{ ns/pF}) C_L$
			20	40	ns	$6\text{ ns} + (0,28\text{ ns/pF}) C_L$

	V_{DD} V	TYPICAL FORMULA FOR P (μW)	
Dynamic power dissipation per package (P)	5	$1200 f_i + \sum (f_o C_L) \times V_{DD}^2$	where f_i = input freq. (MHz) f_o = output freq. (MHz) C_L = load capacitance (pF) $\sum (f_o C_L)$ = sum of outputs V_{DD} = supply voltage (V)
	10	$5500 f_i + \sum (f_o C_L) \times V_{DD}^2$	
	15	$16\,400 f_i + \sum (f_o C_L) \times V_{DD}^2$	