

**GATE J-K MASTER-SLAVE FLIP-FLOPS**

- 16 MHz TOGGLE RATE (typ.) AT  $V_{DD} - V_{SS} = 10V$
- GATED INPUTS
- QUIESCENT CURRENT SPECIFIED TO 20v FOR HCC DEVICE
- 5V, 10V AND 15V PARAMETRIC RATINGS
- INPUT CURRENT OF 100nA AT 18V AND 25°C FOR HCC DEVICE
- 100% TESTED FOR QUIESCENT CURRENT
- MEETS ALL REQUIREMENTS OF JEDEC TENTATIVE STANDARD No 13 A, "STANDARD SPECIFICATIONS FOR DESCRIPTION OF B SERIES CMOS DEVICES"

inputs is transferred to the Q and  $\bar{Q}$  outputs on the positive edge of the clock pulse. SET and RESET inputs (active high) are provided for asynchronous operation.

**DESCRIPTION**

The **HCC4095B/4096B** (extended temperature range) and **HCF4095B/4096B** (intermediate temperature range) are monolithic integrated circuits, available in 14 lead dual in-line plastic or ceramic package and plastic micropackage.

The **HCC/HCF4095B** and **HCC/HCF4096B** are J-K Master-Slave Flip-Flops featuring separate AND gating of multiple J and K inputs. The gated J-K input control transfer of information into the master section during clocked operation. Information on the J-K

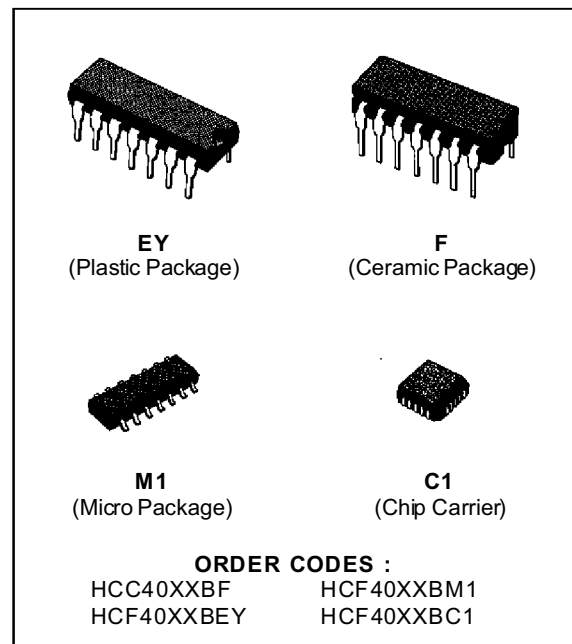

**PIN CONNECTIONS**

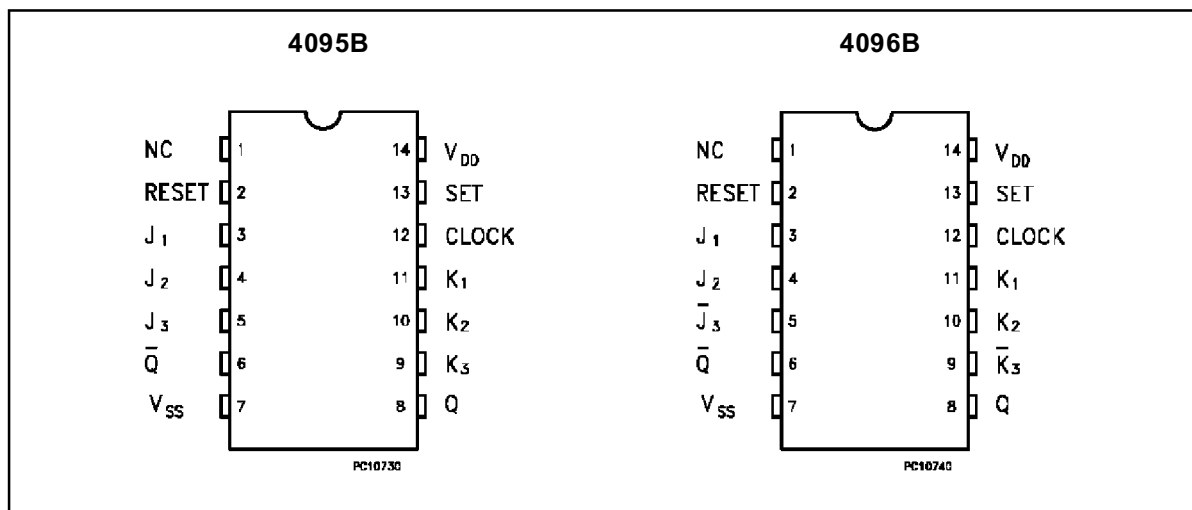

FUNCTIONAL DIAGRAMS

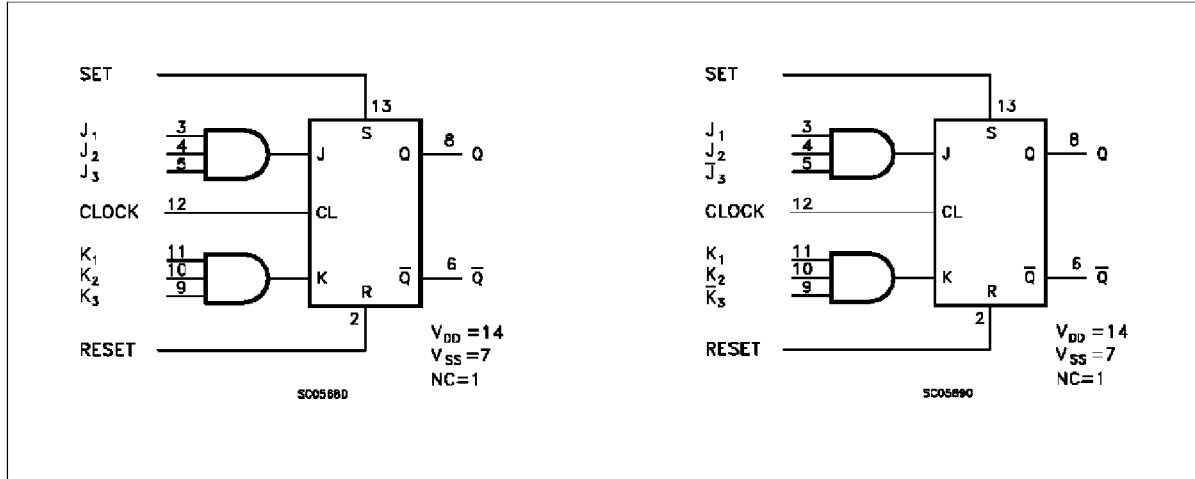

LOGIC DIAGRAM

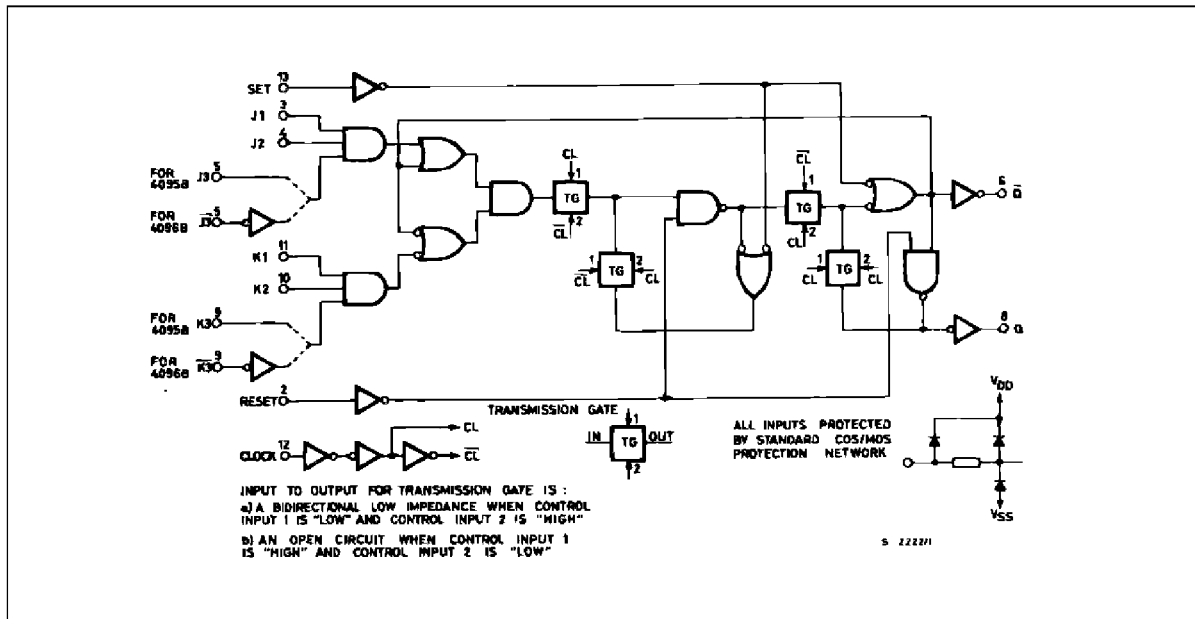

TRUTH TABLES

SYNCHRONOUS OPERATION (S=0 R=0)

Inputs Before Positive Clock Transition		Outputs After Positive Clock Transition	
J *	K *	Q	Q̄
0	0	No Change	
0	1	0	1
1	0	1	0
1	1	Toggles	

\* For 4095B J = J1 • J2 • J3, K = K1 • K2 • K3  
 \* For 4096B J = J1 • J2 • J3, K = K1 • K2 • K3

ASYNCHRONOUS OPERATION (J and K DON'T CARE)

S	R	Q	Q̄
0	0	No Change	
0	1	0	1
1	0	1	0
1	1	0	0

0 = V<sub>SS</sub>, 1 = V<sub>DD</sub>

**ABSOLUTE MAXIMUM RATING**

Symbol	Parameter	Value	Unit
V <sub>DD</sub> *	Supply Voltage: <b>HCC</b> Types <b>HCF</b> Types	-0.5 to +20	V
		-0.5 to +18	V
V <sub>i</sub>	Input Voltage	-0.5 to V <sub>DD</sub> + 0.5	V
I <sub>I</sub>	DC Input Current (any one input)	± 10	mA
P <sub>tot</sub>	Total Power Dissipation (per package) Dissipation per Output Transistor for Top = Full Package Temperature Range	200	mW
		100	mW
T <sub>op</sub>	Operating Temperature: <b>HCC</b> Types <b>HCF</b> Types	-55 to +125	°C
		-40 to +85	°C
T <sub>stg</sub>	Storage Temperature	-65 to +150	°C

Stresses above those listed under "Absolute Maximum Ratings" may cause permanent damage to the device. This is a stress rating only and functional operation of the device at these or any other conditions above those indicated in the operational sections of this specification is not implied. Exposure to absolute maximum rating conditions for external periods may affect device reliability.

\* All voltage values are referred to V<sub>SS</sub> pin voltage.

**RECOMMENDED OPERATING CONDITIONS**

Symbol	Parameter	Value	Unit
V <sub>DD</sub>	Supply Voltage: <b>HCC</b> Types <b>HCF</b> Types	3 to 18	V
		3 to 15	V
V <sub>I</sub>	Input Voltage	0 to V <sub>DD</sub>	V
T <sub>op</sub>	Operating Temperature: <b>HCC</b> Types <b>HCF</b> Types	-55 to +125	°C
		-40 to +85	°C

## HCC/HCF4095B HCC/HCF4096B

### STATIC ELECTRICAL CHARACTERISTICS (over recommended operating conditions)

Symbol	Parameter		Test Conditions				Value						Unit	
			V <sub>I</sub> (V)	V <sub>O</sub> (V)	I <sub>O</sub>   ( $\mu$ A)	V <sub>DD</sub> (V)	T <sub>LOW</sub> *		25 °C			T <sub>HIGH</sub> *		
							Min.	Max.	Min.	Typ.	Max.	Min.		Max.
I <sub>L</sub>	Quiescent Current	HCC Types	0/5			5		1		0.02	1		30	$\mu$ A
			0/10			10		2		0.02	2		60	
			0/15			15		4		0.02	4		120	
			0/20			20		20		0.04	20		600	
		HCF Types	0/5			5		4		0.02	4		30	
			0/10			10		8		0.02	8		60	
			0/15			15		16		0.02	16		120	
V <sub>OH</sub>	Output High Voltage	0/5		< 1	5	4.95		4.95			4.95		V	
		0/10		< 1	10	9.95		9.95			9.95			
		0/15		< 1	15	14.95		14.95			14.95			
V <sub>OL</sub>	Output Low Voltage	5/0		< 1	5		0.05			0.05		0.05	V	
		10/0		< 1	10		0.05			0.05		0.05		
		15/0		< 1	15		0.05			0.05		0.05		
V <sub>IH</sub>	Input High Voltage		4.5	< 1	5	3.5		3.5			3.5		V	
			9	< 1	10	7		7			7			
			13.5	< 1	15	11		11			11			
V <sub>IL</sub>	Input Low Voltage		0.5	< 1	5		1.5			1.5		1.5	V	
			1	< 1	10		3			3		3		
			1.5	< 1	15		4			4		4		
I <sub>OH</sub>	Output Drive Current	HCC Types	0/5	2.5		5	-2		-1.6	-3.2		-1.15	mA	
			0/5	4.6		5	-0.64		-0.51	-1		-0.36		
			0/10	9.5		10	-1.6		-1.3	-2.6		-0.9		
			0/15	13.5		15	-4.2		-3.4	-6.8		-2.4		
		HCF Types	0/5	2.5		5	-1.53		-1.36	-3.2		-1.1		
			0/5	4.6		5	-0.52		-0.44	-1		-0.36		
			0/10	9.5		10	-1.3		-1.1	-2.6		-0.9		
			0/15	13.5		15	-3.6		-3.0	-6.8		-2.4		
I <sub>OL</sub>	Output Sink Current	HCC Types	0/5	0.4		5	0.64		0.51	1		0.36	mA	
			0/10	0.5		10	1.6		1.3	2.6		0.9		
			0/15	1.5		15	4.2		3.4	6.8		2.4		
		HCF Types	0/5	0.4		5	0.52		0.44	1		0.36		
			0/10	0.5		10	1.3		1.1	2.6		0.9		
			0/15	1.5		15	3.6		3.0	6.8		2.4		
I <sub>IH</sub> , I <sub>IL</sub>	Input Leakage Current	0/18	Any Input			18		$\pm 0.1$		$\pm 10^{-5}$	$\pm 0.1$		$\pm 1$	$\mu$ A
		0/15	Any Input			15		$\pm 0.3$		$\pm 10^{-5}$	$\pm 0.3$		$\pm 1$	
C <sub>I</sub>	Input Capacitance	Any Input							5	7.5			pF	

\* T<sub>LOW</sub> = -55 °C for HCC device; -40 °C for HCF device.

\* T<sub>HIGH</sub> = +125 °C for HCC device; +85 °C for HCF device.

The Noise Margin for both "1" and "0" level is: 1V min. with V<sub>DD</sub> = 5V, 2V min. with V<sub>DD</sub> = 10V, 2.5V min. with V<sub>DD</sub> = 15V

## HCC/HCF4095B HCC/HCF4096B

**DYNAMIC ELECTRICAL CHARACTERISTICS** ( $T_{amb} = 25\text{ }^{\circ}\text{C}$ ,  $C_L = 50\text{ pF}$ ,  $R_L = 200\text{ K}\Omega$ , typical temperature coefficient for all  $V_{DD}$  values is  $03\text{ } \%/^{\circ}\text{C}$ , all input rise and fall times =  $20\text{ ns}$ )

Symbol	Parameter	Test Conditions		Value			Unit
			$V_{DD}$ (V)	Min.	Typ.	Max.	
$t_{PLH}$ $t_{PHL}$	Propagation Delay Time		5		250	500	ns
			10		100	200	
			15		75	150	
$t_{PLH}$ $t_{PHL}$	Propagation Delay Time (Set or Reset)		5		150	300	ns
			10		75	150	
			15		50	100	
$t_{THL}$ $t_{TLH}$	Transition Time		5		100	200	ns
			10		50	100	
			15		40	80	
$f_{CL}$	Maximum Clock Input Frequency		5	3.5	7		MHz
			10	8	16		
			15	12	24		
$t_w$	Clock Pulse Width		5	140	70		ns
			10	60	30		
			15	40	20		
$t_r$ $t_f$	Clock Input Rise or Fall Time		5			15	$\mu\text{s}$
			10			5	
			15			5	
$t_w$	Set or Reset Pulse Width		5	200	100		ns
			10	100	50		
			15	50	25		
$t_{setup}$	Data Setup Time		5	400	200		ns
			10	160	80		
			15	100	50		

Typical Output Low (sink) Current Characteristics

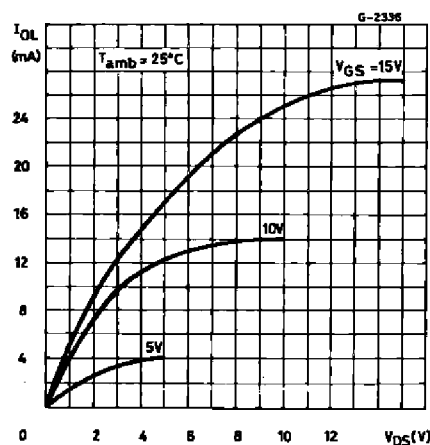

Minimum Output low (sink) Current Characteristics

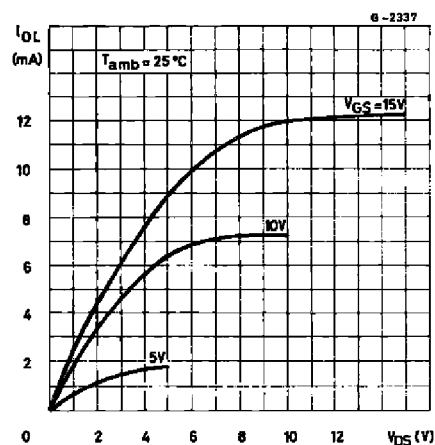

# HCC/HCF4095B HCC/HCF4096B

Typical Output High (source) Current Characteristics

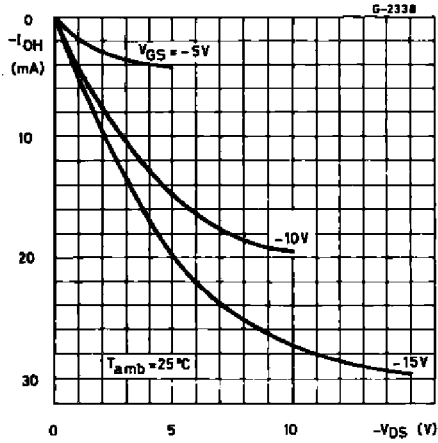

Minimum Output High (source) Current Characteristics

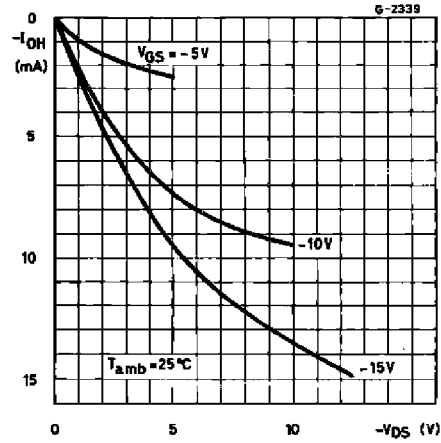

Typical Propagation Delay Time vs Load Capacitance

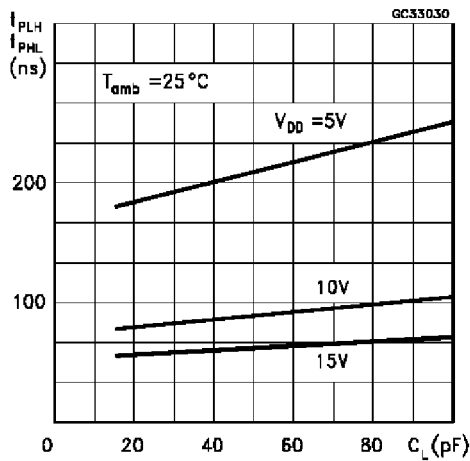

Typical Transition Time vs Load Capacitance

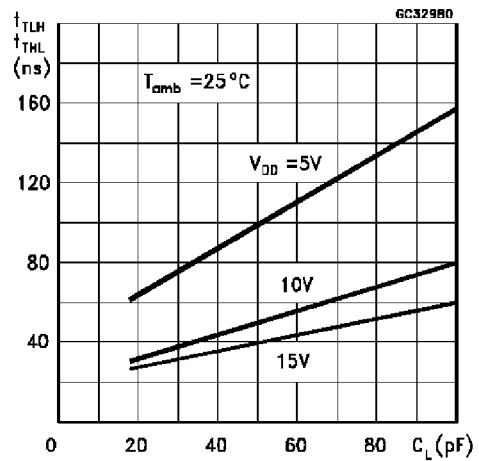

Typical Clock Frequency vs Supply Voltage (Toggle Mode)

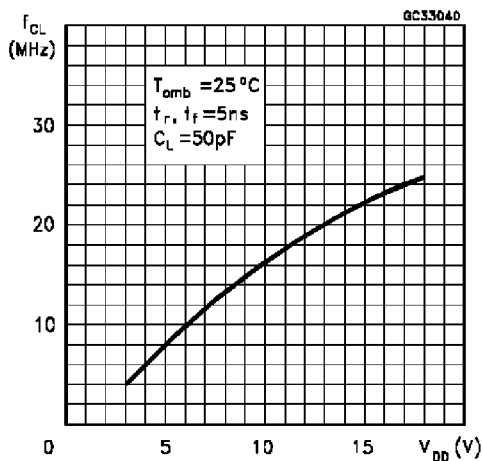

Typical Power Power Dissipation Vs. Input Clock Frequency

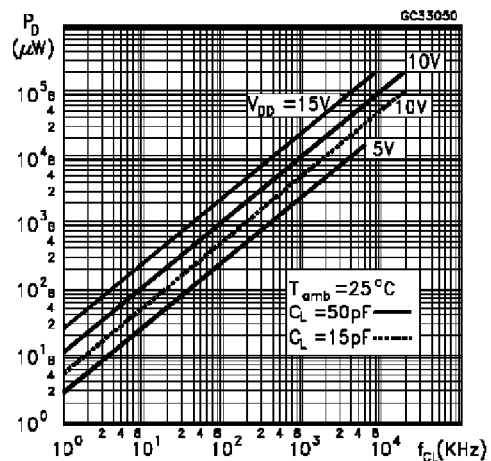

TYPICAL APPLICATIONS

T-type Flip-Flop

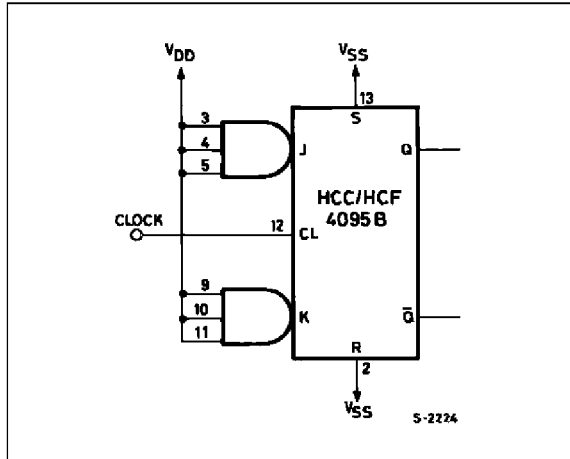

D-type Flip-Flop

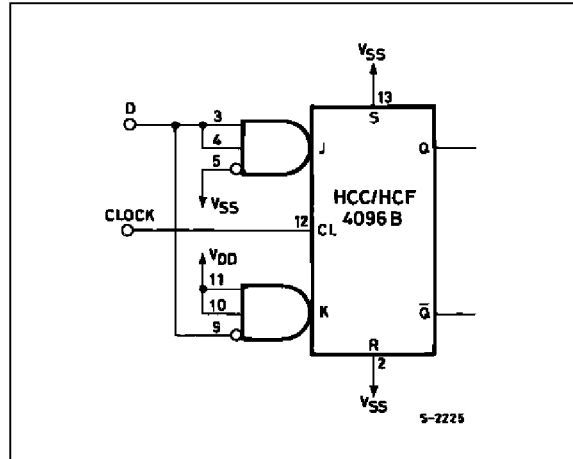

Synchronous Binary Divide by Ten Counter

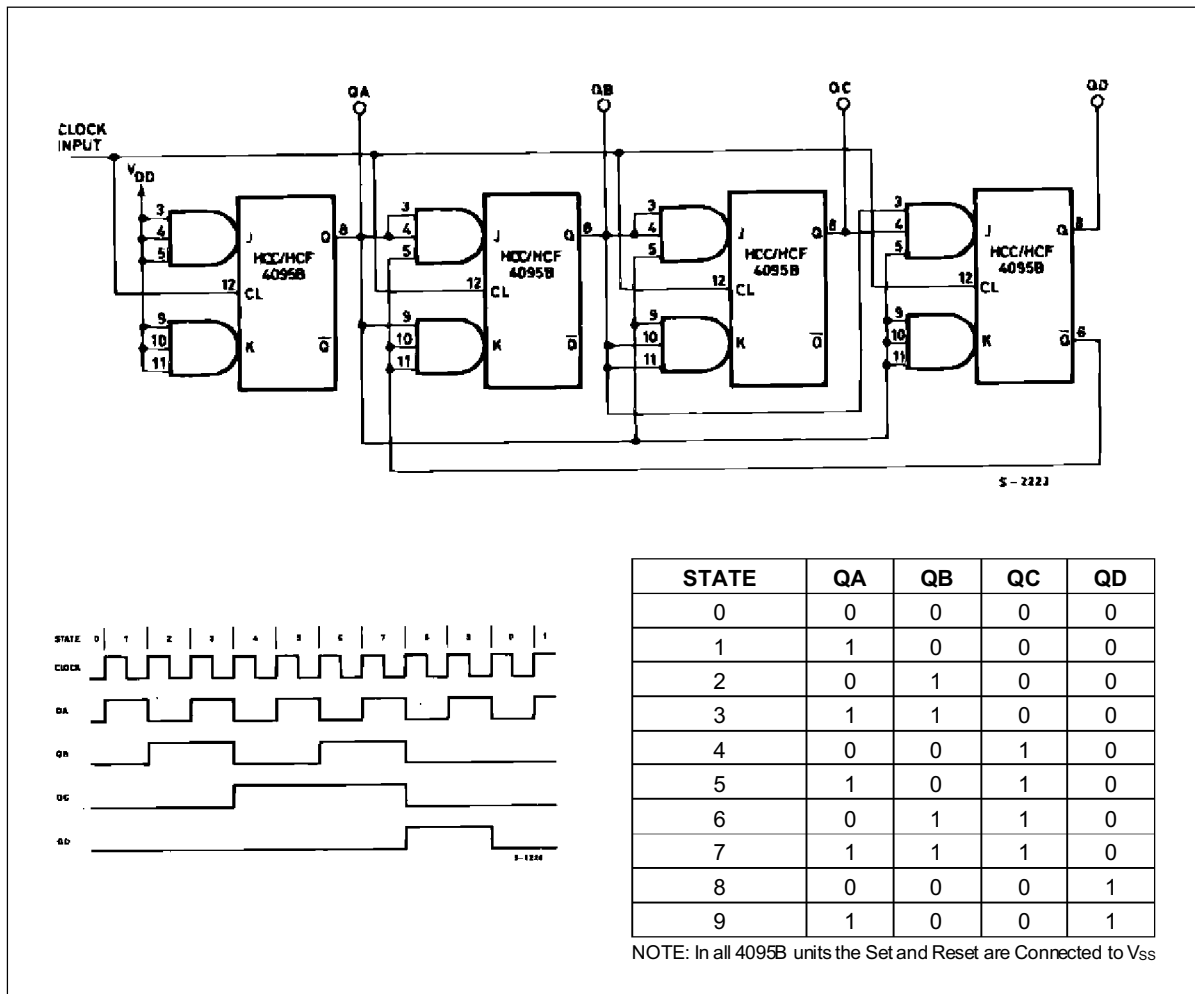

WAVEFORMS

Propagation Delay, Transition and Setup Time

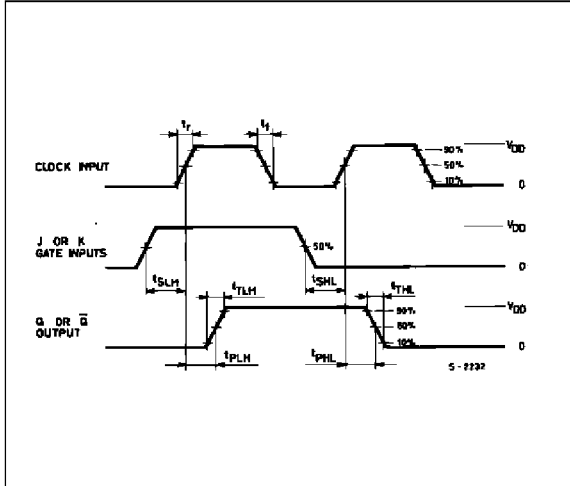

Clock Pulse Rise and Fall Time

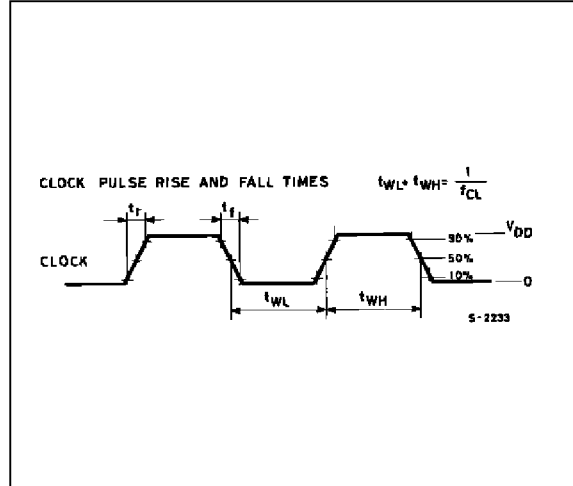

TEST CIRCUITS

Quiescent Device Current

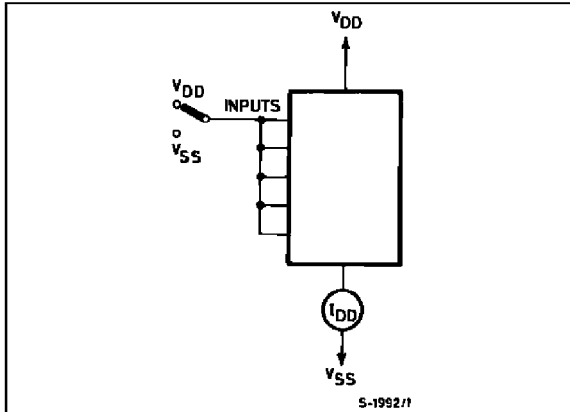

Noise Immunity.

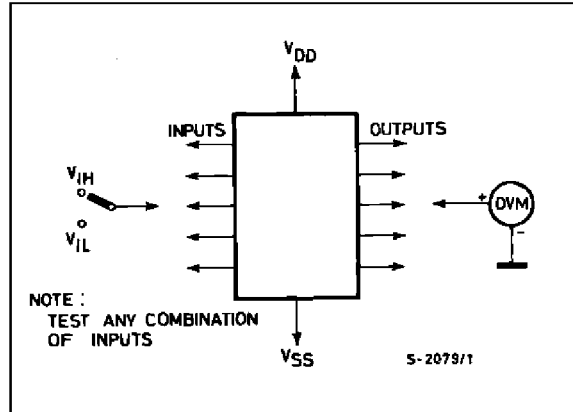

Input Leakage Current.

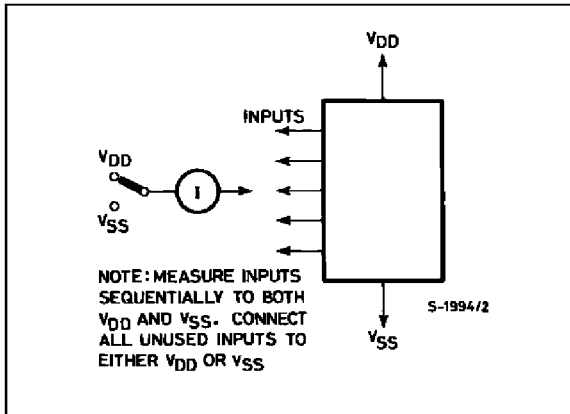



**Plastic DIP14 MECHANICAL DATA**

DIM.	mm			inch		
	MIN.	TYP.	MAX.	MIN.	TYP.	MAX.
a1	0.51			0.020		
B	1.39		1.65	0.055		0.065
b		0.5			0.020	
b1		0.25			0.010	
D			20			0.787
E		8.5			0.335	
e		2.54			0.100	
e3		15.24			0.600	
F			7.1			0.280
I			5.1			0.201
L		3.3			0.130	
Z	1.27		2.54	0.050		0.100

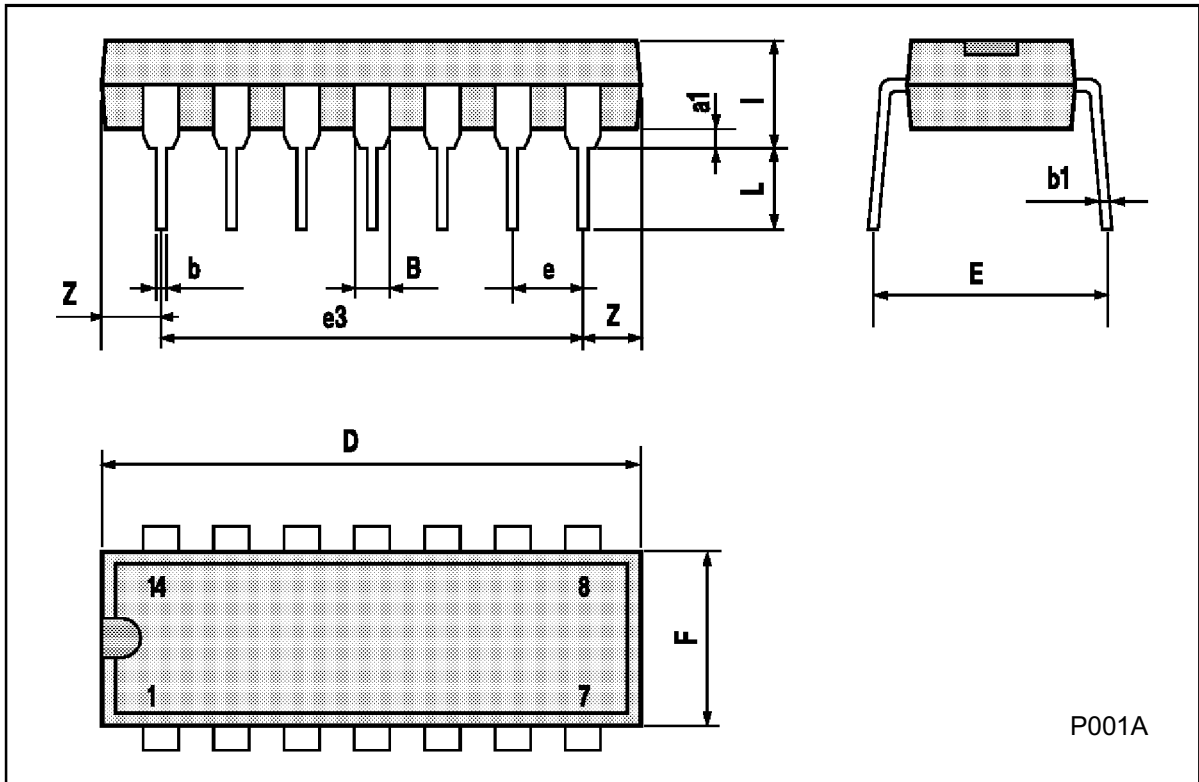

**Ceramic DIP14/1 MECHANICAL DATA**

DIM.	mm			inch		
	MIN.	TYP.	MAX.	MIN.	TYP.	MAX.
A			20			0.787
B			7.0			0.276
D		3.3			0.130	
E	0.38			0.015		
e3		15.24			0.600	
F	2.29		2.79	0.090		0.110
G	0.4		0.55	0.016		0.022
H	1.17		1.52	0.046		0.060
L	0.22		0.31	0.009		0.012
M	1.52		2.54	0.060		0.100
N			10.3			0.406
P	7.8		8.05	0.307		0.317
Q			5.08			0.200

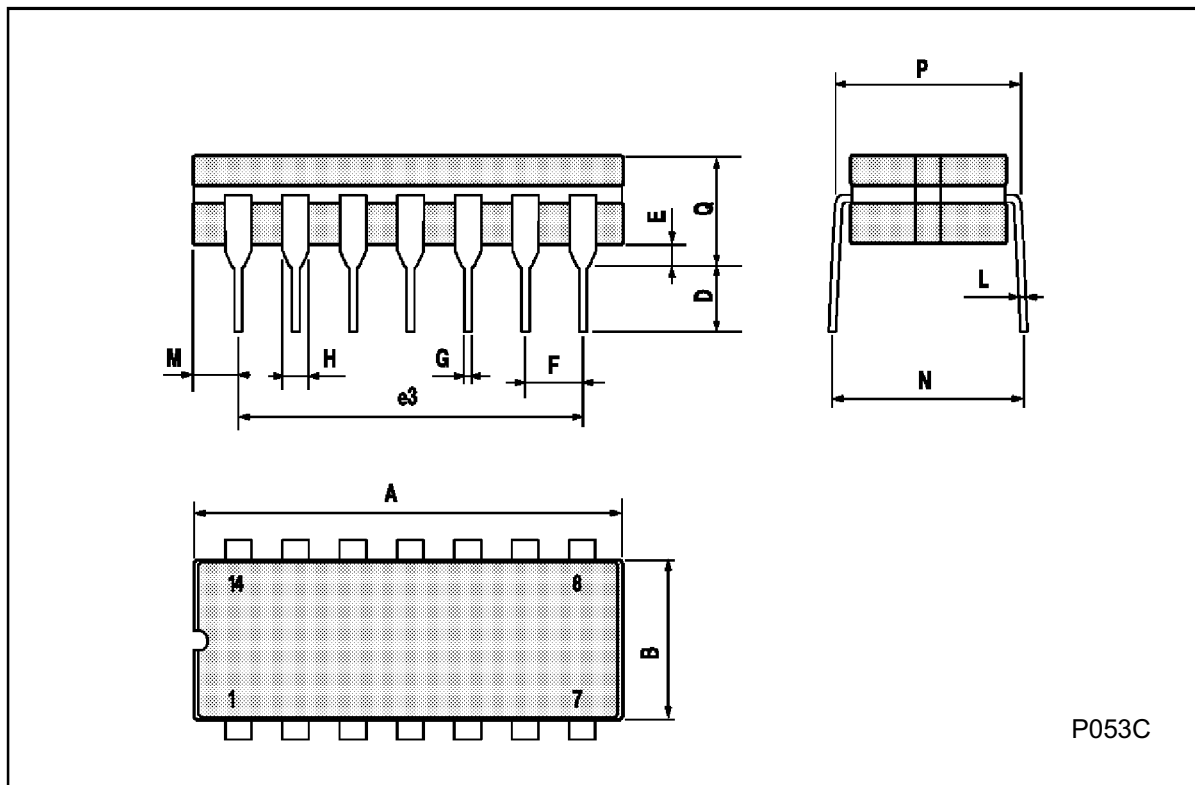

**SO14 MECHANICAL DATA**

DIM.	mm			inch		
	MIN.	TYP.	MAX.	MIN.	TYP.	MAX.
A			1.75			0.068
a1	0.1		0.2	0.003		0.007
a2			1.65			0.064
b	0.35		0.46	0.013		0.018
b1	0.19		0.25	0.007		0.010
C		0.5			0.019	
c1	45° (typ.)					
D	8.55		8.75	0.336		0.344
E	5.8		6.2	0.228		0.244
e		1.27			0.050	
e3		7.62			0.300	
F	3.8		4.0	0.149		0.157
G	4.6		5.3	0.181		0.208
L	0.5		1.27	0.019		0.050
M			0.68			0.026
S	8° (max.)					

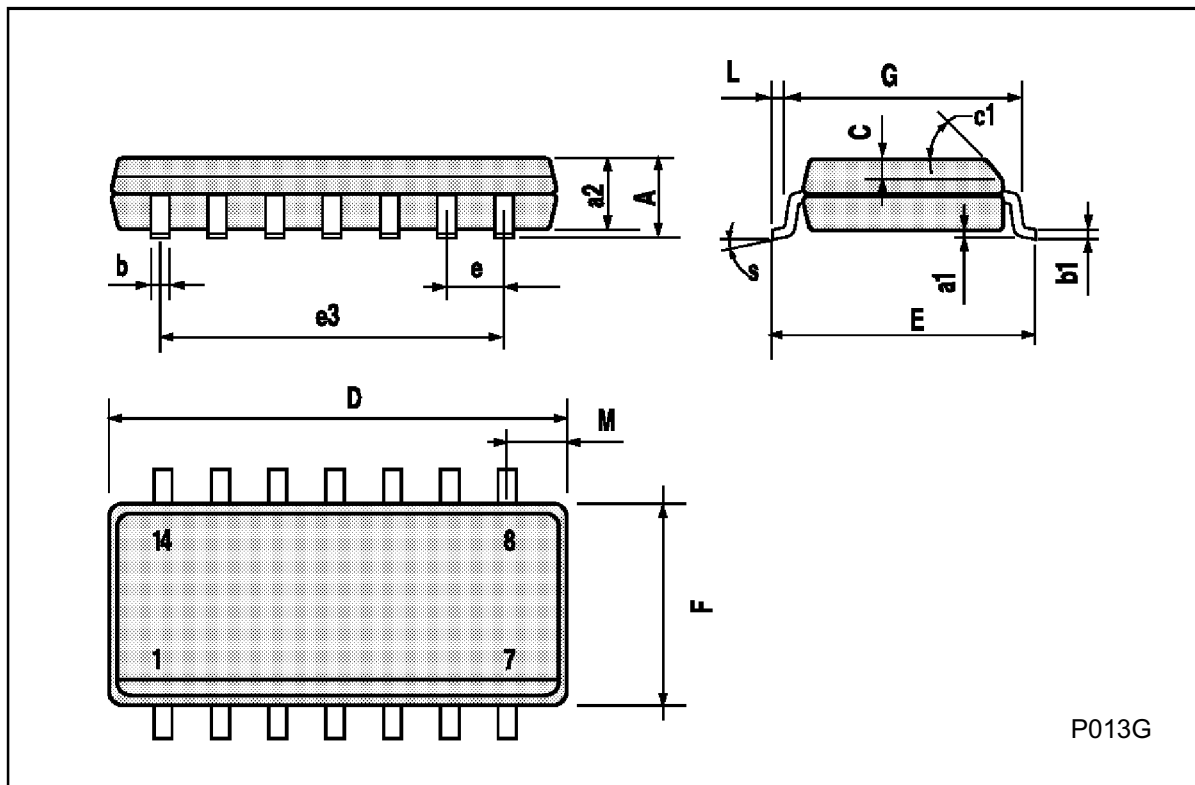

P013G

**PLCC20 MECHANICAL DATA**

DIM.	mm			inch		
	MIN.	TYP.	MAX.	MIN.	TYP.	MAX.
A	9.78		10.03	0.385		0.395
B	8.89		9.04	0.350		0.356
D	4.2		4.57	0.165		0.180
d1		2.54			0.100	
d2		0.56			0.022	
E	7.37		8.38	0.290		0.330
e		1.27			0.050	
e3		5.08			0.200	
F		0.38			0.015	
G			0.101			0.004
M		1.27			0.050	
M1		1.14			0.045	

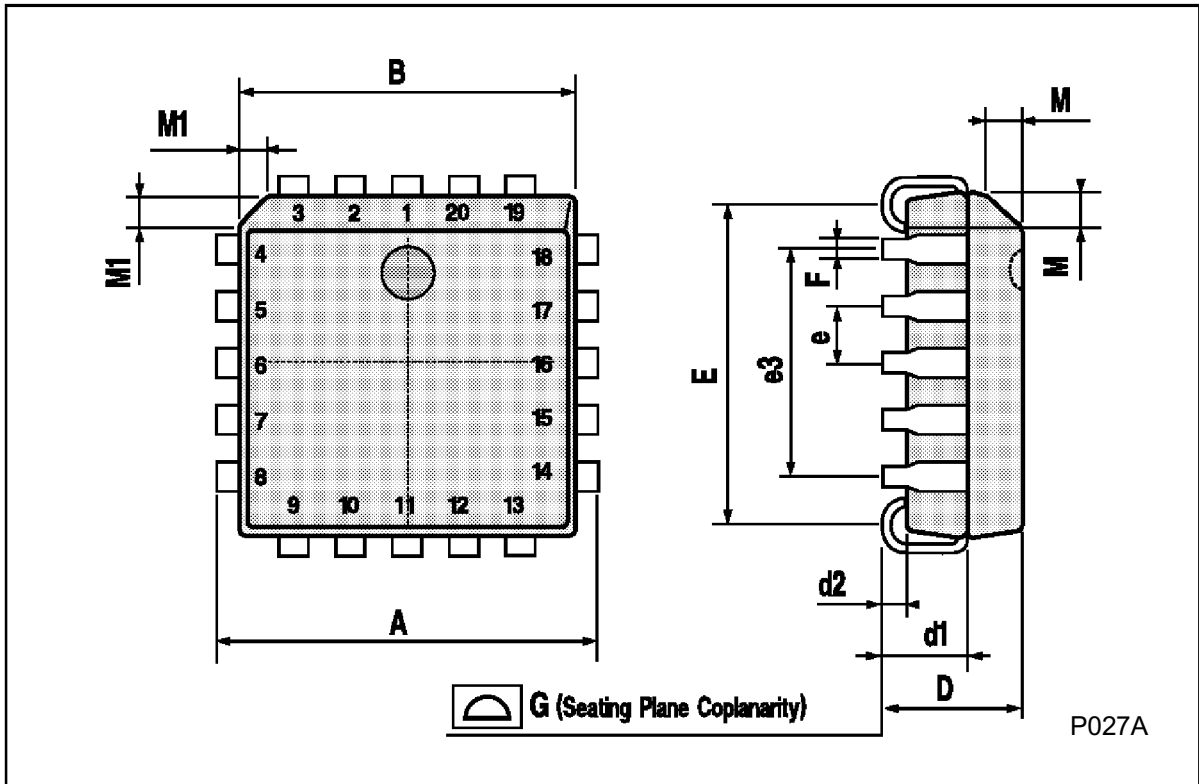

Information furnished is believed to be accurate and reliable. However, SGS-THOMSON Microelectronics assumes no responsibility for the consequences of use of such information nor for any infringement of patents or other rights of third parties which may result from its use. No license is granted by implication or otherwise under any patent or patent rights of SGS-THOMSON Microelectronics. Specifications mentioned in this publication are subject to change without notice. This publication supersedes and replaces all information previously supplied. SGS-THOMSON Microelectronics products are not authorized for use as critical components in life support devices or systems without express written approval of SGS-THOMSON Microelectronics.

© 1994 SGS-THOMSON Microelectronics - All Rights Reserved

SGS-THOMSON Microelectronics GROUP OF COMPANIES  
Australia - Brazil - France - Germany - Hong Kong - Italy - Japan - Korea - Malaysia - Malta - Morocco - The Netherlands -  
Singapore - Spain - Sweden - Switzerland - Taiwan - Thailand - United Kingdom - U.S.A